

W. P. WALKER.
Improvement in Marine Camels.

No. 132,506.

Patented Oct. 22, 1872.

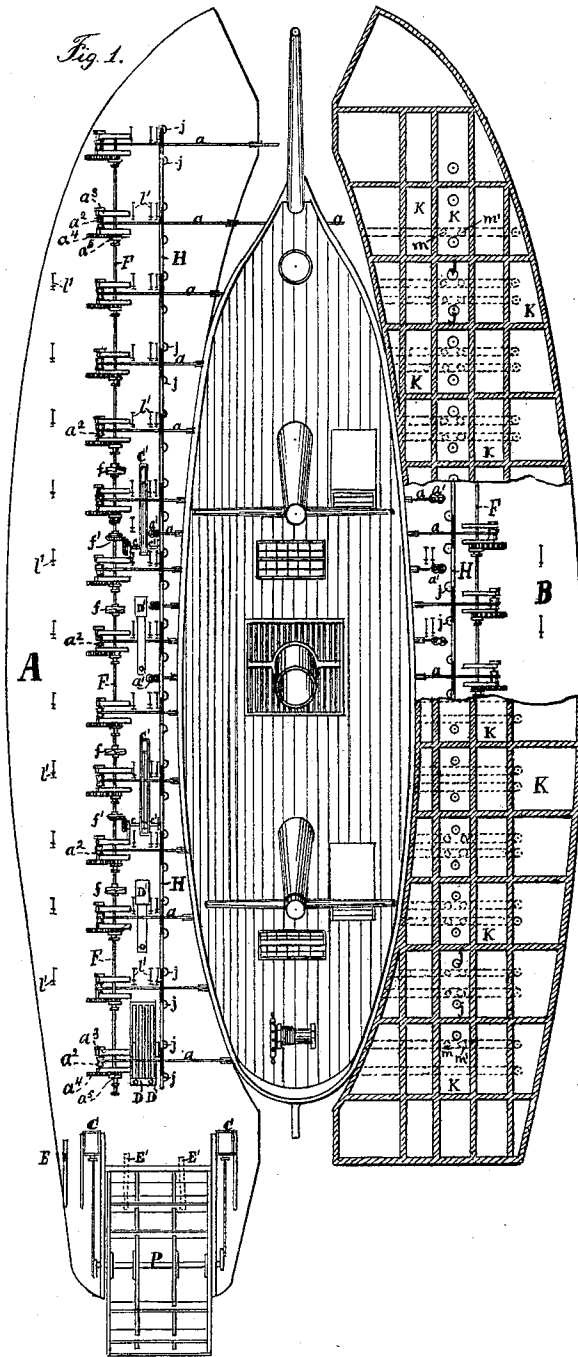

WITNESSES:

Herm. Lauter.
R. W. Downum an

INVENTOR:

W. P. Walker,
by his attys,
Clayton & Co.

W. P. WALKER. Improvement in Marine Camels.

No. 132,506.

Patented Oct. 22, 1872.

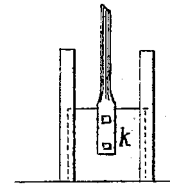
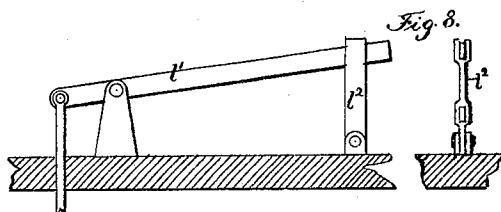
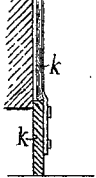
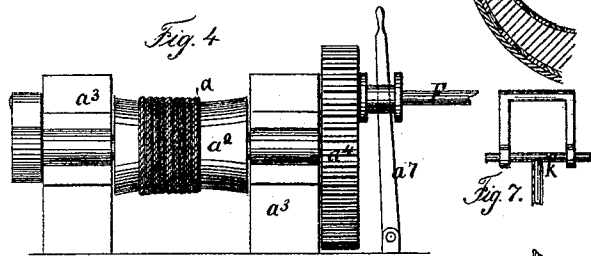
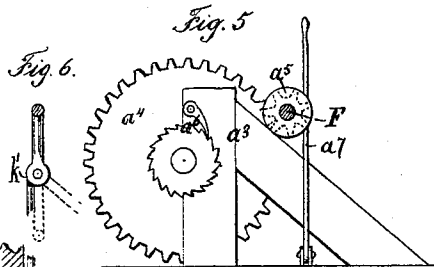
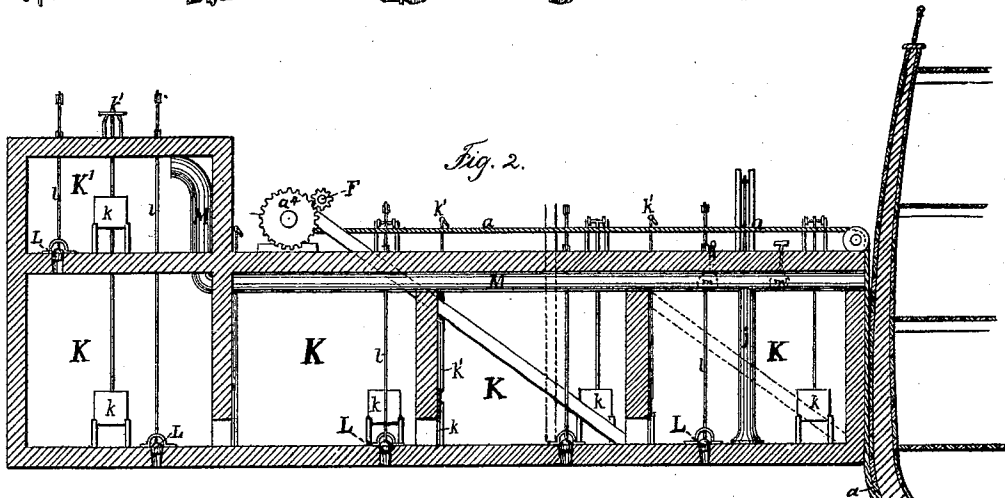
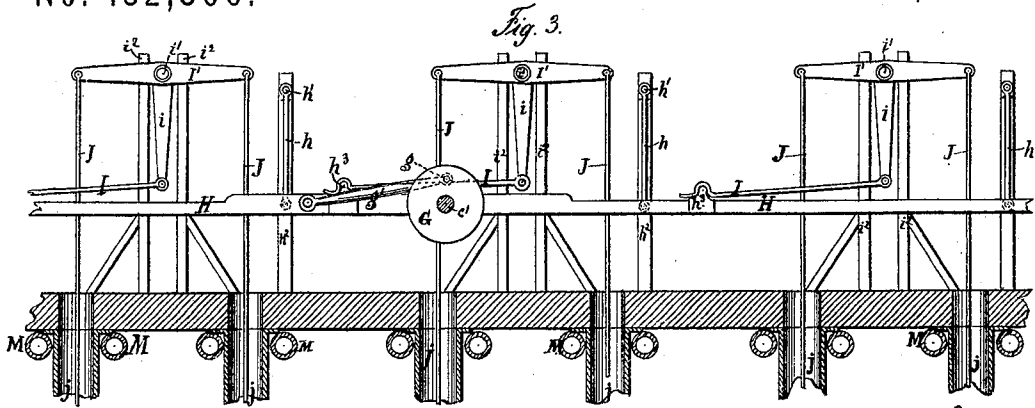

WITNESSES:

Herm. Lauter.
R. W. Drouman

INVENTOR:

Wm. P. Walker,
by his attys,
Clayton & Co.

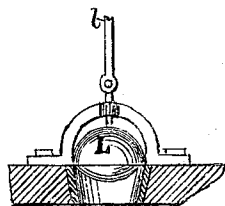

UNITED STATES PATENT OFFICE.

WILLIAM P. WALKER, OF MEMPHIS, TENNESSEE.

IMPROVEMENT IN MARINE CAMELS.

Specification forming part of Letters Patent No. 132,506, dated October 22, 1872.

To all whom it may concern:

Be it known that I, WILLIAM P. WALKER, of Memphis, in the county of Shelby and in the State of Tennessee, have invented certain new and useful Improvements in Lighters for Lifting Vessels and Cargoes over Shoal-Water; and I do hereby declare that the following is a full, clear, and exact description thereof, reference being had to the accompanying drawing and to the letters of reference marked thereon.

The nature of my invention consists in constructing a steam-propelled lighter for lifting and propelling heavy-laden vessels over shoals, &c., by making the lighter in two separate divisions that are connected by exceedingly stout and strong ropes or hawsers, which divisions are made right and left, in order to conform to the general curvature of the right and left sides of vessels to be lifted, because such vessels are to rest on the aforementioned hawsers and between the two divisions of the lighter when said vessels are lifted over shoals, &c. Each division is also provided with independent motive power to propel the division, operate the series of pumps, and the windlasses on which the hawsers are wound. Each division is subdivided into many water-tight compartments, provided with sluice-gates, pipes, and valves, by means of which the said compartments may be made to communicate with each other; and each compartment is furnished in its bottom with a valve to open and close an opening, through which the water in which the lighter floats may quickly and copiously enter when it is desired to sink the lighter a certain depth in order to lift a laden vessel. The lighter, as the water is pumped from her, is forced up by the outside water, and, the hawsers having been drawn taut under the vessel's bottom, they will, as fast as the lighter rises out of the water, lift up the vessel the requisite height, when she can be readily and safely propelled by the lighter through the shoal-water, all of which will more fully hereinafter appear.

To enable others skilled in the art to make and use my invention, I will now more specifically describe its construction and operation.

In the drawing, Figure 1, Sheet I, is a plan view of my lighter with a vessel to be lifted between the two divisions and the greater portion of the lighter's right division shown in

plan section; Fig. 2, Sheet II, is an enlarged vertical cross-section of the lighter's left division about "midship;" a part of a vessel, being lifted, is also shown in section; Fig. 3, same Sheet, is an enlarged view of a portion of the system of pumps; Figs. 4 and 5 are detail views of one of the windlasses used; Figs. 6 and 7 are detail views of one of the sluice-gates and its handle; and Fig. 8 illustrates one of the valves in the bottom of each compartment of the lighter with the means of operating it.

Like letters indicate like parts in the several figures of the drawing.

The lighter is shown in Fig. 1, Sheet I, with A as the left and B the right division. Each division is built of stout timber, and of the form indicated in Figs. 1 and 2, and arranged and equipped throughout like the other. To propel division A I provide it with the steam-engines C, (see Fig. 1,) which drive the stern paddle-wheel P. The said engines are supplied with steam from boilers D. To guide the division A two "balance-rudders," E', (shown in dotted lines, Fig. 1,) and a common rudder, E, are provided. Power to operate the other apparatus of the division is furnished by steam-engines C' C' supplied with steam from boilers D'. From each of these engines power is communicated, through shafts *c c* and *c' c'*, to the apparatus for winding the hawsers *a*, and to the pumping apparatus. Hawsers *a* are made very stout and strong, and are each secured at one end to firmly-set posts or "bits" *a'* on one division, and each, at their other end, to drums or windlasses *a''* on the other division of the lighter. Each hawser *a* is sufficiently long to extend from division to division, and under the bottom of any heavy-laden vessel that may be lifted by the lighter. (See Fig. 2, Sheet II.) The number of these hawsers *a* will depend upon the size and weight of the vessels and cargoes to be lifted by the lighter. The drums or windlasses *a''*, around which the hawsers *a* are wound, have their journals set in standards *a'''*, (see Figs. 4 and 5, Sheet II;) and each drum *a''* receives, through the cog-wheels *a'''*, same figures, from pinion-wheels *a''''* on the main driving-shafts F F. *a''''* is the ratchet-wheel and ratchet for holding the drum or windlass *a''* stationary when it is disconnected from engine C'. The drums *a''* are all in a line, and are all driven by shafts F, which are

practically but two shafts, because of the clutches f on the ends of the several parts in which the shafts F are made. (See Fig. 1, Sheet I.) These shafts F communicate their power, received, through the bevel-gearing f' , from engine-shafts e , to the drums a^2 through the pinion-wheels a^5 , which are thrown in and out of gear with cog-wheels a^4 by means of lever a^7 , Figs. 4 and 5. Shafts c' transmit motion to wheels G , (see Fig. 3, Sheet II,) and, through their crank-pins g , to the connecting-rod g' that imparts its motion to the longitudinal rod or "traveler" H ; and the "traveler" H , as it swings on the pendulum rods or levers h , (which are pivoted at h^1 on posts or standards h^2), transfers its motion to its saddles h^3 and the connecting-rods I , (which are readily disconnected from said saddles h^3 and the pumps stopped,) and so through to the vertical pump-levers i . They set in motion the beams I' , and as they rock on their shafts i^1 , which are supported in any suitable frame, as i^2 , the pump-rods J are set to work in the lifting-pumps j . Each division of the lighter, A and B , is divided into many compartments. (See K , Figs. 1 and 2.) They are made water-tight, but communicate with each other, when desirable, by means of sluice-gates k . These gates k have handles k' extending up above the deck, so as to be conveniently operated by hand. (See Fig. 2, Sheet II.) The construction of these sluice-gates k is thoroughly illustrated in Figs. 2, 6, and 7. Each compartment K also has an opening in its bottom, which is opened and closed by a valve, L , operated by rod l and lever l^1 . l^2 is a stop for lever l^1 . (See Fig. 8.) There is also provided an upper tier of compartments (marked K' , Fig. 2, where only one of them is shown in section) above the lower tier marked K , and on the side of the division furthest from the vessel when the lighter is lifting a vessel. These compartments K' are likewise furnished with sluice-gates k and valves L . This upper tier of compartments K' is only to be filled when it is desired to afford proper ballast to the lighter when engaged in lifting and propelling a very deeply laden vessel. In order to fill these compartments K' there are provided pipes M , which are secured to and under the deck and lead from the pumps j , which supply them with water, up to the top of said compartments K' and there discharge the water drawn from lower compartments K . Pipes M are extended also, at their opposite ends, to the side of the division nearest the vessels, when they are lifted by the lighter; and, by means of two valves or cocks, m and m' , in each of the pipes M , (one cock on each side of the pump,) the water may be discharged from the pumps j and made to fill the compartments K' or be conveyed overboard next to the vessel being lifted.

To operate my lighter when constructed as above described: Upon approaching the vessel to be assisted by the lighter, by "porting" helm of division B and "starboarding" the helm of division A the bows of the division

will readily swing apart and so pass upon either side of the vessel approached, the hawsers a having all been previously slacked enough to pass beneath the vessel. When the divisions are in proper position in relation to the vessel engines C are stopped and engines C' are set in motion and communicate it, through shafts e , bevel-gearing f' , to main shafts F , which, through pinions a^5 , operate the cogs a^4 , (see Figs. 4 and 5, Sheet II,) and the drums or windlasses a^2 , thus taking in the slack of the hawsers a . All of the sinking-valves L are now opened and the water rushes in and rapidly fills the compartments K . As the divisions sink we continue taking in the slack of the hawsers a until the divisions have sunk as low as desirable, when all of the hawsers a are made as taut as possible, equalizing the strain or bearing at all points, and the valves L are shut down while the ratchet and ratchet-wheel a^6 hold the drums a^2 entirely secure and stationary. The power of engines C' is now diverted from shafts e to shafts c' , in order to set in motion the pumping apparatus above set forth. The water in compartments K is first displaced by the pumping, emptying the row of compartments next the vessel being elevated first, then opening the sluice-gates k' between that and the next row of compartments K , when the latter are emptied; and so with the other compartments K . By means of gates k the water is permitted quickly and easily to circulate throughout the entire lighter, or any portion thereof necessary; and, having the water under this perfect control, the lighter can at all times be kept perfectly trim, straight, and level. Should the lift be extraordinary, we can counterbalance any extra weight by discharging the water into the compartments K' by closing stop-cocks m' in discharge-pipes M and opening stop-cock m . As the lighter is freed of water she is, with her hawsers, buoyed or lifted up, and raises the vessel in the hawsers as in a swing. When the lighter is freed of the water the pumping is stopped and engines C are caused to propel the vessel thus lifted swiftly and safely over the shoals, sand-bars, &c., and drops the vessel in the proper depth of water, or where desired. With powerful engines C and large wheels P , which are necessarily so far apart, it will readily be seen that my lighter with a vessel can be handled with perfect ease and safety and made to ascend or descend the most tortuous channels. It will be perceived that as the hawsers a are to be of immense size there is no danger of injuring the hull or even the "copper" of a vessel, which is a great advantage over chains or other means in use; and, as it is not contemplated to raise a vessel up out of the water, but only to such height as necessary, the hawsers suspending her as in a swing, the vessel will have the same pressure of water upon her, and as evenly distributed at all times, thus relieving her of any strain.

The foregoing are some of the advantages

of my invention over others of the class of inventions for towing or carrying vessels.

Having thus fully described my invention, what I claim as new, and desire to secure by Letters Patent, is—

1. The combination, in a lighter constructed with compartments, substantially as shown, of sluice-gates *k* and pumps *j*, under the arrangement described, whereby the series of compartments next the vessel or body to be raised are successively emptied as far as required, and the lighter thereby kept on an even keel, as and for the purposes set forth.

2. The combination with the above of tubes *M*, stop-cocks *m m'*, and compartments *K'*, whereby an additional balance, if required, may be obtained, substantially as described.

In testimony that I claim the above-described certain new and useful improvements in lighters for lifting vessels and cargoes over shoal water, I have hereunto signed my name this 31st day of May, 1872.

WM. P. WALKER.

Witnesses:

M. B. TREZEVANT,
W. R. CUNNINGHAM.