

No. 659,999.

Patented Oct. 16, 1900.

H. A. BLANCHARD.
SEWING MACHINE NEEDLE.

(Application filed May 27, 1899.)

(No Model.)

Fig. 1.

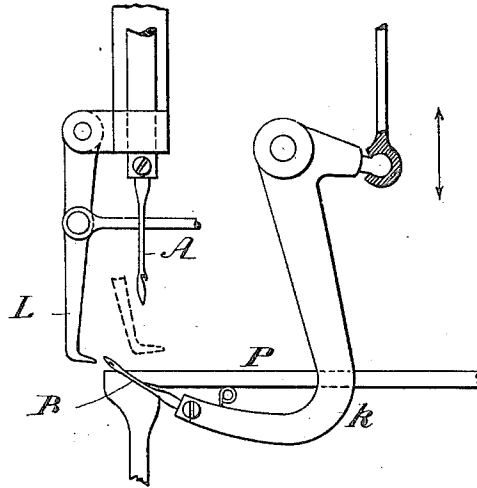

Fig. 3.

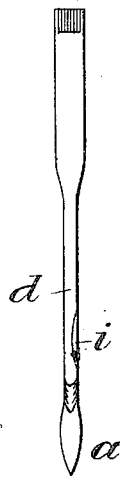

Fig. 4.

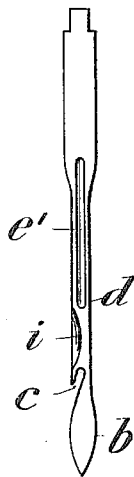
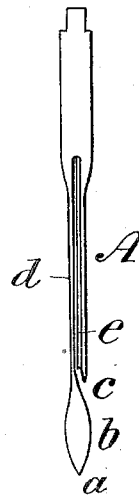

Fig. 2.



Witnesses:
Hermann Bormann.
C. Bormann

Inventor:
Helen A. Blanchard
By Hermann Bormann
Att'y.

UNITED STATES PATENT OFFICE.

HELEN A. BLANCHARD, OF PHILADELPHIA, PENNSYLVANIA.

SEWING-MACHINE NEEDLE.

SPECIFICATION forming part of Letters Patent No. 659,999, dated October 16, 1900.

Application filed May 27, 1899. Serial No. 718,602. (No model.)

To all whom it may concern:

Be it known that I, HELEN A. BLANCHARD, a citizen of the United States, residing at Philadelphia, in the county of Philadelphia and State of Pennsylvania, have invented a new and useful Sewing-Machine Needle, of which the following is a specification.

My invention relates to needles used in sewing-machines in which one or more threads are employed to form the stitches; and it consists of a needle adapted to perforate or pierce goods to be sewed and carry with it in an open notch the thread supplied by a secondary needle, hook, or shuttle, which thread is then cast off by the said notched needle, the latter returning empty to its highest or initial position; and my invention further consists of a needle provided with a point adapted to perforate or pierce goods to be sewed, a gradual first increasing and then decreasing section contiguous to said point, and a notch cut obliquely in one side or edge of said needle and just above the said section to engage the thread, carry it through the goods, and then cast off the same in such a manner that partly-concealed loops are formed on top of the goods; and my invention further consists of the improvements hereinafter more fully described, and pointed out in the claims.

My invention will be more fully understood taken in connection with the accompanying drawings, forming part hereof, and in which—

Figure 1 is a view showing stitch-forming mechanism of a sewing-machine of which my new needle forms a part. Fig. 2 is a view showing the new needle in front elevation. Fig. 3 is a side view of the same, and Fig. 4 is a rear elevation of the said needle.

Referring now to the drawings for a further description of my invention, and particularly to Figs. 2 to 4, A is the needle proper, provided with the point *a*, an increasing and then decreasing section *b* forming a sort of lancet-point to pierce the goods to be sewed and leave an aperture sufficiently large to allow the thread carried through such aperture freedom of movement. Just above this increasing and then decreasing section is provided the notch *c*, cut on one side and running upwardly and obliquely to the shank *d* of the needle, said notch being adapted to engage a thread above the goods to be sewed

and when the needle A descends carry or push the thread through the goods pierced by the point of the needle A, where thread is cast off for further operations, as will be more fully explained with reference to Fig. 1. On the front side of the needle A, Fig. 2, is formed a thread-groove *e*, extending from the notch *c* up to the top of the shank *d*, and on the rear side of the needle, Fig. 3, is formed a depression or cavity *i* just above the notch *c* to enable a secondary needle B, carrying the thread, to engage the loop formed by the needle A when the notch *c* is below the goods or throat-plate of the machine. Above this depression or cavity *i* on the rear side of the needle A is provided another thread-groove *e'*, extending from above the notch *c* up to the top of the shank *d*.

For the sake of illustrating the operation and use of my new sewing-machine needle I have shown in Fig. 1 the stitch-forming mechanism of a sewing-machine of which the said needle forms a part. In Fig. 1, B is a thread-carrying needle secured to an oscillating arm *k*, fulcrumed and oscillated in any preferred manner, said needle B operating, however, below the cloth-plate P. L is a hook fulcrumed above the cloth-plate P and adapted to engage the thread on the rear side of the needle B and bring it into the path of the needle A, which latter pierces the goods and carries the thread below the cloth-plate P. At this time the needle A being in its lowest position, the thread-carrying needle engages the loop of the thread from the needle A by moving in back of the needle A and toward the left in Fig. 1, while the hook L, when the needle B is in its highest position, takes the thread from the needle B and moves it in loop form under the needle A, as before stated, the needle A in the meanwhile having returned empty to its highest or initial position and ready to engage the thread presented by the hook L to repeat the operation just described.

I am aware that sewing-machine needles have been provided with slots or notches on one side for the purpose of quickly threading and unthreading such needles; but I am not aware that needles for sewing-machines have been made for the purposes described—*i. e.*, to bring a thread through the goods to be

sewed and then cast off the thread in order to form a stitch.

Having thus described the nature and objects of my invention, what I claim as new, and desire to secure by Letters Patent, is—

1. A sewing-machine needle having a point, a section first increasing and then decreasing and contiguous to said point, a notch cut in one side of said needle, above said section, both walls of the said notch running upward and toward the shank and obliquely to the shaft of said needle, substantially as and for the purposes set forth.

2. A sewing-machine needle having a point, a section first increasing and then decreasing on both the front and rear side of the body of the needle and contiguous to said point, a notch cut in one side of said needle obliquely to the shaft and upwardly toward the shank of said needle and a thread-groove in the rear and front side of said needle, substantially as and for the purposes set forth.

3. A sewing-machine needle having a point, a section first increasing and then decreasing on both the front and rear side of the body of said needle and contiguous to said point,

a notch cut upwardly toward the shank and in one side of said needle obliquely to the shaft of said needle, the body of the needle on the opposite side of the notch bulging out contiguous to the point, a thread-groove in the rear and front side and a cavity or depression on the rear side, substantially as and for the purposes set forth.

4. A sewing-machine needle having a thread-engaging notch lying in a plane oblique to the longitudinal axis of the needle and having its mouth opening downwardly, said needle having a point-section below the notch, one wall of which section beginning at the bottom of the notch passes in a curvilinear path to the needle-point, and a thread-groove passing out of the bottom of the notch and upwardly along the body of the needle, substantially as and for the purposes set forth.

In witness whereof I have hereunto set my hand in the presence of two subscribing witnesses.

HELEN A. BLANCHARD.

Witnesses:

HERMANN BORMANN,
LOUISE P. BLANCHARD.