

(12) INTERNATIONAL APPLICATION PUBLISHED UNDER THE PATENT COOPERATION TREATY (PCT)

(19) World Intellectual Property
Organization

International Bureau

(43) International Publication Date
18 June 2020 (18.06.2020)



(10) International Publication Number
WO 2020/123145 A1

(51) International Patent Classification:

B29C 70/20 (2006.01) *B29C 65/00* (2006.01)
B29C 70/34 (2006.01) *B29C 70/46* (2006.01)

EE, ES, FI, FR, GB, GR, HR, HU, IE, IS, IT, LT, LU, LV, MC, MK, MT, NL, NO, PL, PT, RO, RS, SE, SI, SK, SM, TR), OAPI (BF, BJ, CF, CG, CI, CM, GA, GN, GQ, GW, KM, ML, MR, NE, SN, TD, TG).

(21) International Application Number:

PCT/US2019/063285

(22) International Filing Date:

26 November 2019 (26.11.2019)

(25) Filing Language:

English

(26) Publication Language:

English

(30) Priority Data:

62/773,871 30 November 2018 (30.11.2018) US
16/695,955 26 November 2019 (26.11.2019) US

(71) Applicant: **ARRIS COMPOSITES INC.** [US/US]; 2743 Ninth Street, Berkeley, California 94710 (US).

(72) Inventors: **ESCOWITZ, Ethan**; 2418 Bonar St., Berkeley, California 94702 (US). **DAVIDSON, Erick**; 114 Alta Ave., Piedmont, California 94611 (US).

(74) Agent: **BREYER, Wayne S.**; Kaplan Breyer Schwarz, LLP, 90 Matawan Road, Suite 201, Matawan, New Jersey 07747 (US).

(81) Designated States (unless otherwise indicated, for every kind of national protection available): AE, AG, AL, AM, AO, AT, AU, AZ, BA, BB, BG, BH, BN, BR, BW, BY, BZ, CA, CH, CL, CN, CO, CR, CU, CZ, DE, DJ, DK, DM, DO, DZ, EC, EE, EG, ES, FI, GB, GD, GE, GH, GM, GT, HN, HR, HU, ID, IL, IN, IR, IS, JO, JP, KE, KG, KH, KN, KP, KR, KW, KZ, LA, LC, LK, LR, LS, LU, LY, MA, MD, ME, MG, MK, MN, MW, MX, MY, MZ, NA, NG, NI, NO, NZ, OM, PA, PE, PG, PH, PL, PT, QA, RO, RS, RU, RW, SA, SC, SD, SE, SG, SK, SL, SM, ST, SV, SY, TH, TJ, TM, TN, TR, TT, TZ, UA, UG, US, UZ, VC, VN, ZA, ZM, ZW.

(84) Designated States (unless otherwise indicated, for every kind of regional protection available): ARIPO (BW, GH, GM, KE, LR, LS, MW, MZ, NA, RW, SD, SL, ST, SZ, TZ, UG, ZM, ZW), Eurasian (AM, AZ, BY, KG, KZ, RU, TJ, TM), European (AL, AT, BE, BG, CH, CY, CZ, DE, DK,

Published:

- with international search report (Art. 21(3))
- before the expiration of the time limit for amending the claims and to be republished in the event of receipt of amendments (Rule 48.2(h))

(54) Title: COMPRESSION-MOLDED FIBER-COMPOSITE PARTS AND METHODS OF FABRICATION

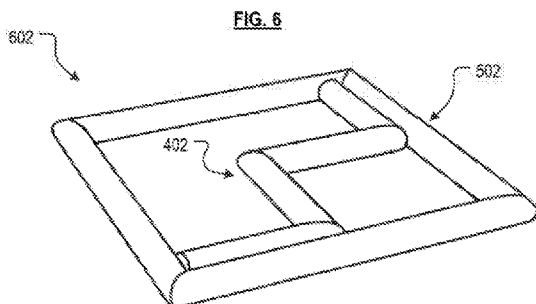

(57) Abstract: Fiber-reinforced composite parts include select portions containing a plurality of co-aligned fiber. The parts are fabricated by placing substantially preforms (402, 502, 602, 702, 802) into a mold cavity to form a layout, and compression molding the layout to consolidate the preforms to provide a fiber-reinforced composite part (974, 1100, 1110, 1120, 1130, 1140). Different sections of the part can be derived from preforms having different shapes and different compositions.



WO 2020/123145 A1

COMPRESSION-MOLDED FIBER-COMPOSITE PARTS AND METHODS OF FABRICATION

Statement of Related Cases

[0001] This case claims priority of U.S. serial no. 62/773,871 filed November 30, 2018, serial no. 15/612,720 filed June 2, 2017, and serial no. 15,840,826 filed December 12, 2017, all of which are incorporated herein by reference. If there are any contradictions or inconsistencies in language between this specification and one or more of the cases that have been incorporated by reference, the language of this specification takes precedence and controls interpretation of the claims herein.

Field of the Invention

[0002] This invention relates to fiber-composite parts.

Background of the Invention

[0003] Various manufacturing methods have been developed to produce fiber-reinforced composite parts. Present methods can be time consuming, limited to the use of certain materials, and/or constrained by part geometries. And such manufacturing methods are not suited for fabricating fiber-reinforced composite parts efficiently at high volume.

Summary

[0004] The present invention provides fiber-reinforced composite parts ("fiber composites"), and a way to fabricate them that avoids some of the costs and disadvantages of the prior art.

[0005] In accordance with the illustrative embodiment, fiber composites are formed from relatively rigid, fiber-bundle-based preforms. Such preforms are formed from towpreg; that is, a preform is a sized, or sized and shaped portion of towpreg. The towpreg, and hence the preforms, contain thousands of fiber that are impregnated with a matrix material, such as polymer resin.

[0006] In a most basic embodiment, preforms have a simple linear shape (*i.e.*, a rod). In some alternative embodiments, preforms may have any one of a variety of relatively complex shapes, including, without limitation, non-linear shapes, closed-form shapes, planar shapes, non-planar (3D) shapes, and multi-layer shapes, as appropriate for a particular mold and the part fabricated therefrom.

[0007] In accordance with some embodiments, the preforms are organized in a particular arrangement and orientation—a layup—in the mold cavity of a female mold half. The mold is then closed, and a part is fabricated via compression molding techniques (*i.e.*, application of pressure and heat).

[0008] In some embodiments, preforms maintain their shape and location in a mold cavity to a substantial extent during the compression-molding process. Consequently, the fibers and matrix from any given preform can be directed to a desired volumetric region of a part being fabricated. In accordance with the present teachings, preforms can be made to differ in any one or more of a variety of characteristics, including, without limitation, the matrix material (*e.g.*, different thermoplastics, different fillers, *etc.*), fiber type (*e.g.*, carbon fiber vs. glass, *etc.*), and fiber distribution. Moreover, the fiber-bundle-based preforms disclosed herein can be bent in ways that a ribbon or sheet cannot. In light of these features, the use of fiber-bundle-based preforms as constituents of a layup provides an unprecedented ability to control fiber alignment at arbitrary volumetric locations within a part. As such, the present invention enables characteristics/attributes/properties of arbitrary regions of a part to be controlled to an extent hitherto not possible, such as to address localized stress issues, or impart different degrees of stiffness to different regions of a part, or to selectively provide electrical and/or thermal conductivity or electrical and/or thermal insulation to regions of a part.

[0009] In some embodiments, the present invention provides a method for fabricating a fiber-composite part, wherein the method comprises:

forming a layup, wherein the layup includes a first fiber-bundle-based preform and a second fiber-bundle based preform, and wherein:

- (a) the first preform is rigid, has a first shape, and comprises a first plurality of continuous, co-aligned fibers impregnated with a first matrix material,
- (b) the second preform is rigid, has a second shape, and comprises a second plurality of continuous, co-aligned fibers impregnated with a second matrix material; and

consolidating the first preform and the second preform in a mold cavity via the application of heat and pressure; and

cooling the consolidated first preform and second preform, thereby providing a fiber-composite part.

[0010] In some embodiments, the present invention provides a method for fabricating a fiber-composite part, wherein the method comprises:

forming a layup, wherein the layup includes a first fiber-bundle-based preform and a

second fiber-bundle based preform, and wherein:

- (a) the first preform is rigid, has a first shape that is non-planar wherein the first shape includes two bends that are out-of-plane with respect to one another, and comprises a first plurality of continuous fibers impregnated with a thermoplastic resin matrix,
- (b) the second preform is rigid, has a second shape, and comprises a second plurality of continuous fibers impregnated with the thermoplastic resin matrix; and consolidating the first preform and the second preform in a mold cavity via the application of heat and pressure; and cooling the consolidated first preform and second preform, thereby providing a fiber-composite part.

[0011] In some embodiments, the present invention provides a fiber-composite part comprising:

a first section at a first volumetric region of the fiber-composite part, the first section having:

- (a) a first portion, wherein the first portion comprises a first plurality of co-aligned fiber;
- (b) a second portion, wherein the second portion comprises a second plurality of co-aligned fiber;

a second section at a second volumetric region of the fiber-composite part, wherein the first section and the second section are contiguous with one another, the second section having:

- (a) a first portion, wherein the first portion of the second section comprises the first plurality of co-aligned fiber;
- (b) a second portion, wherein the second portion of the second section comprises a third plurality of co-aligned fiber, wherein the second plurality of co-aligned fiber and the third plurality of co-aligned fiber differ from one another in a characteristic selected from the group consisting of fiber type, fiber volume fraction, and fiber distribution.

Brief Description of the Drawings

[0012] **FIG. 1A** depicts towpreg for use in conjunction with embodiments of the present invention.

[0013] **FIG. 1B** depicts a segment of the towpreg of FIG. 1A, the segment being a linear preform.

[0014] **FIG. 2A** depicts a longitudinal cross-section of a first embodiment of the preform of FIG. 1B.

[0015] **FIG. 2B** depicts a transverse cross-section of the first embodiment of the preform of FIG. 1B.

[0016] **FIG. 3A** depicts a longitudinal cross-section of a second embodiment of the preform of FIG. 1B.

[0017] **FIG. 3B** depicts a transverse cross-section of the second embodiment of the preform of FIG. 1B.

[0018] **FIG. 4** depicts an embodiment of an open form, planar, nonlinear preform in accordance with the present invention.

[0019] **FIG. 5** depicts a first embodiment of a closed form, planar, non-linear preform in accordance with the present invention.

[0020] **FIG. 6** depicts a second embodiment of a closed form, planar, non-linear preform in accordance with the present invention.

[0021] **FIG. 7** depicts a third embodiment of a closed form, planar, non-linear preform in accordance with the present invention.

[0022] **FIG. 8** depicts an embodiment of an open form, non-planar, non-linear preform in accordance with the present invention

[0023] **FIG. 9A** depicts a first embodiment of a layup of preforms in accordance with the present teachings.

[0024] **FIG. 9B** depicts a second embodiment of a layup of preforms in accordance with the present teachings.

[0025] **FIG. 9C** depicts a part formed from the layup of FIGs. 9A or 9B.

[0026] **FIG. 10A** depicts a segment of the layup of FIG. 9B.

[0027] **FIG. 10B** depicts a longitudinal cross-section of a region of a part formed from the segment of the layup shown in FIG. 10A.

[0028] **FIG. 10C** depicts a transverse cross-section along the axis A-A of FIG. 10B.

[0029] **FIG. 10D** depicts a transverse cross-section along the axis B-B of FIG. 10B.

[0030] **FIG. 10E** depicts an exploded view of the part of FIG. 9C, showing sections and portions of the part.

[0031] **FIGs. 11A-11E** depict embodiments of complex open-framework parts, as can be fabricated in accordance with the present teachings.

Detailed Description

[0032] The following terms are defined below for use in this disclosure and the appended claims:

- **"Fiber composite"** is a material that includes two primary components: a matrix material and a fibrous material. The fibrous material –fibers– are typically responsible for the strength of the composite, in addition to any other properties they contribute. The matrix, typically formed from a polymer resin, surrounds and supports the fibers, maintaining their relative positions and preventing abrasion and environmental attack thereof. The combination of the fibers and resin is synergistic, with the resulting properties depending on the specific fiber, resin, and fiber volume fraction.
- **"Fiber"** means an individual strand of fibrous material. A fiber has a length that is much greater than its diameter.
- **"Matrix material"** is a polymer resin, typically a thermoplastic or a b-stage (*i.e.*, partially cured) thermoset. The matrix material can also be a ceramic.
- **"Co-aligned fiber"** refers to a plurality of fibers oriented in the same direction.
- **"Tow"** means "a bundle of fibers," and those terms are used interchangeably herein unless otherwise specified. Tow is typically available with fibers numbering in the thousands: a 1K tow, 3K tow, 6K tow, *etc.* The term **"filament"** may also be used synonymously with "tow" herein.
- **"Prepreg"** means fibers that are impregnated with resin.
- **"Towpreg"** or **"Prepreg Tow"** means a fiber bundle (*i.e.*, a tow) that is impregnated with resin.
- **"Preform"** or **"Filament Subunit"** means a sized, or sized and shaped portion of tow/tow-preg, wherein the cross section of the fiber bundle has an aspect ratio (width:thickness) of between about 0.25 to about 6. For use herein, the terms preform and filament subunit explicitly exclude sized/shaped "tape," which typically has an aspect ratio –cross section, as above– of between about 10 to about 30. The terms preform and filament subunit also explicitly exclude sheets of fiber and laminates.

- "**Continuous fiber**" refers to a fiber extending from one end of a preform/filament subunit to the other end thereof. In some contexts (*i.e.*, some of applicant's other patent filings), a continuous fiber/continuous preform refers to a fiber/preform having a length that is about equal to the length of a major feature of a mold in which the fiber/bundles are placed. Continuous fiber is distinct from the "chopped fiber" or "cut fiber," as those terms are typically used in the art. Chopped or cut fiber has a random orientation in a mold and a final part and bears no predefined relationship to the length of any feature of a mold/part. A fiber-bundle-based preform in accordance with the present teachings does not include chopped or cut fiber.
- "**Continuous matrix**" refers to a matrix that is homogenous throughout a cross-section (*e.g.*, of a preform, of a part, of a specified region of a part).
- "**Lattice**" refers to a framework consisting of straight or curved segments that intersect and enclose void spaces.
- "**About**" or "**Substantially**" means +/- 20% with respect to a stated figure or nominal value.

Additional definitions are provided in the specification in context.

[0033] Other than in the examples, or where otherwise indicated, all numbers expressing, for example, quantities of ingredients used in the specification and in the claims are to be understood as being modified in all instances by the term "about." Accordingly, unless indicated to the contrary, the numerical parameters set forth in the following specification and attached claims are understood to be approximations that may vary depending upon the desired properties to be obtained in ways that will be understood by those skilled in the art. Generally, this means a variation of at least +/- 20%.

[0034] Moreover, it is to be understood that any numerical range recited herein is intended to include all sub-ranges encompassed therein. For example, a range of "1 to 10" is intended to include all sub-ranges between (and including) the recited minimum value of about 1 and the recited maximum value of about 10, that is, having a minimum value equal to or greater than about 1 and a maximum value of equal to or less than about 10.

[0035] FIG. 1A depicts towpreg **100**. The towpreg includes many individual fibers, typically provided in multiples of a thousand (*e.g.*, 1k, 10k, 24k, *etc.*), which are impregnated with a polymer resin matrix. Towpreg can have any one of a variety of cross-

sectional shapes, including, for example, circular, oval, trilobal, polygonal, etc.

[0036] Towpreg can be purchased from suppliers thereof, such as Celanese Corporation of Irving, Texas, or others, or formed on-site via well-known processes such as pultrusion, extrusion, or co-extrusion. In the pultrusion process, a plurality of fibers in the form of a fiber "tow" is pulled through a die and impregnated, under pressure and temperature, with a polymer (typically thermoplastic or thermoset) resin. The process provides, as indicated above, a plurality of fibers embedded within a continuous matrix material.

[0037] Referring now to FIG. 1B, fiber-bundle-based preform **102** is formed by removing a segment of towpreg **100**. In FIG. 1B, preform **102** is a short, linear segment; this is a most basic embodiment of the preforms to which embodiments of the invention are directed. As described in further detail later in this specification, in other embodiments, preforms may have a more complex shape, including non-linear shapes, closed-form shapes, 3D shapes, and multi-layer shapes, as appropriate for a part being fabricated. Such preforms are, in fact, "building blocks" for fabricating fiber-reinforced parts in accordance with the present teachings.

[0038] A preform has a length that is typically substantially greater than its width and substantially greater than its thickness (note that FIG. 1B is not to scale). The length of a preform is determined based on attributes of the part being fabricated. A major influence on preform length is the size of the part. Generally, it is desirable to use the longest preform possible for any given application since a longer preform can contain longer continuous lengths of fiber. For a given part, longer continuous fibers typically result in stronger parts than shorter-length fibers. So, for a very small part, a preform might have a length of about 5 millimeters, while for a large part (e.g., an airplane wing, a vehicle body panel, etc.), a preform might have a length of many meters. Simply put, preform length is application specific.

[0039] A preform can have any suitable cross-sectional (*i.e.*, width and height/thickness) dimensions, as appropriate for the part being fabricated. In some embodiments, the width and height (thickness) of a preform are about equal (e.g., circular cross section, square cross section, etc.). The cross-sectional shape of the preform is, in embodiments of the invention, dictated by the cross-sectional shape of the towpreg, discussed above. The shape, height, and width of a preform can be substantially constant along its length, or can vary.

[0040] It is desirable for a preform to be easily manipulated, such as for placement by

robotics in a mold cavity. Consequently, the materials forming the preform should be in a state that can be readily handled (*e.g.*, solid, rigid, *etc.*) at the temperature of use (typically about 20°C to 30°C). Alternatively, the temperature of the preform can be altered, as necessary, to facilitate handling.

[0041] *Preform Composition.* It is to be understood that the composition/internal structure of a preform is identical to that of the towpreg from which it is sourced.

[0042] Regarding the fibers, the individual fibers in towpreg **100** can have any diameter, which is typically, but not necessarily, in a range of about 1 to about 100 microns. Individual fibers can include an exterior coating such as, without limitation, sizing, to facilitate processing, adhesion of binder, minimize self-adhesion of fibers, or impart certain characteristics (*e.g.*, electrical conductivity, *etc.*).

[0043] Each individual fiber can be solid or hollow core. Each individual fiber can be formed of a single material or multiple materials (such as from the materials listed below), or can itself be a composite. For example, an individual fiber can comprise a core (of a first material) that is coated with a second material, such as an electrically conductive material, an electrically insulating material, a thermally conductive material, or a thermally insulating material.

[0044] In terms of composition, each individual fiber can be, for example and without limitation, carbon, glass, natural fibers, aramid, boron, metal, ceramic, polymer filaments, and others. Non-limiting examples of metal fibers include steel, titanium, tungsten, aluminum, gold, silver, alloys of any of the foregoing, and shape-memory alloys. "Ceramic" refers to all inorganic and non-metallic materials. Non-limiting examples of ceramic fiber include glass (*e.g.*, S-glass, E-glass, AR-glass, *etc.*), quartz, metal oxide (*e.g.*, alumina), aluminosilicate, calcium silicate, rock wool, boron nitride, silicon carbide, and combinations of any of the foregoing. Furthermore, carbon nanotubes can be used. Within an individual preform, all fibers typically have the same composition.

[0045] With respect to the matrix material, any polymer resin—thermoplastic or thermoset—that bonds to itself under heat and/or pressure can be used. Exemplary thermoplastic resins useful in conjunction with embodiments of the invention include, without limitation, acrylonitrile butadiene styrene (ABS), nylon, polyaryletherketones (PAEK), polybutylene terephthalate (PBT), polycarbonates (PC), and polycarbonate-ABS (PC-ABS), polyetheretherketone (PEEK), polyetherimide (PEI), polyether sulfones (PES), polyethylene (PE), polyethylene terephthalate (PET), polyphenylene sulfide (PPS),

polyphenylsulfone (PPSU), polyphosphoric acid (PPA), polypropylene (PP), polysulfone (PSU), polyurethane (PU), polyvinyl chloride (PVC). An exemplary thermoset is epoxy. In some embodiments, a ceramic can be used as the matrix matrix.

[0046] The suitability for use of any particular polymer resin depends, at least in part, on the requirements of the part being fabricated. Such requirements may include desired attributes/characteristics/properties of the part (e.g., aesthetics, density, corrosion resistance, thermal properties, etc.).

[0047] In addition to the polymer resin, the matrix material can include other components such as, for example and without limitation, filler, adhesion promoters, rheology control agents, colorants, and combinations of any of the foregoing.

[0048] The type and amount of filler can be selected to achieve a certain desired property such as tensile strength, elongation, thermal stability, low-temperature flexibility, chemical resistance, low density, electrical conductivity, thermal conductivity, EMI/RFI shielding, static dissipative, or a combination of any of the foregoing. Non-limiting examples of suitable fillers include inorganic fillers such as silica and calcium carbonate, organic fillers such as thermoplastic beads, electrically conductive fillers such as metal, graphite, and graphene, and low-density fillers such as thermally expanded microcapsules. A filler can have any suitable form such as bead, particles, powders, platelets, sheets, or flakes.

[0049] In some embodiments, filler includes non-aligned fiber and/or discontinuous fiber that does not extend fully between the ends of a preform. Such non-aligned fibers can include chopped fibers, milled fibers, or a combination thereof. Non-aligned fibers can include a plurality of non-aligned continuous fibers, including, for example, fiber weaves, twisted fibers, etc.

[0050] **Preform Internal Structure.** Preforms can have a uniform, or a non-uniform internal structure. FIGs. 2A and 2B depict preform **102A** of a first embodiment of towpreg **100** of FIGs. 1A/1B. In the embodiment depicted in FIGs. 2A and 2B, preform **102A** has a uniform internal structure (because the towpreg from which it is sourced has a uniform internal structure).

[0051] FIG. 2A depicts a longitudinal cross-section of preform **102A**. Preform **102A** is linear, which is the most basic implementation of a fiber-bundle-based preform. Preform **102A** includes a plurality of fibers **208**. These fibers are "continuous" since they extend from first end **204A** to second end **206A** of preform **102A**. Furthermore, fibers **208** are

“co-aligned,” since they are all oriented in the same direction. Preform **102A** also includes polymer resin matrix **210**, which surrounds and wets fibers **208**.

[0052] FIG. 2B depicts a transverse cross-section of preform **102A**. In this embodiment, the plurality of co-aligned fibers **208** are substantially uniformly distributed across the transverse cross section (*i.e.*, radially) of preform **102A**.

[0053] FIGs. 3A and 3B depict preform **102B** of a second embodiment of towpreg **100** of FIGs. 1A/1B. In the embodiment depicted in FIGs. 3A and 3B, preform **102B** has a non-uniform internal structure (because the towpreg from which it is sourced has a non-uniform internal structure).

[0054] FIG. 3A depicts a longitudinal cross-section of preform **102B**. Like preform **102A**, preform **102B** includes a plurality of fibers **208**, which are continuous since they fully extend between ends **204B** and **206B** of preform **102B**. The fibers in preform **102B** are also co-aligned, as in preform **102A**.

[0055] Referring now to FIG. 3B, and with continuing reference to FIG. 3A, it can be seen that fibers **208** are not uniformly radially distributed in preform **102B**. Notably, fibers **208** are arranged in a band that is embedded with matrix **210** of preform **102B**. In other words, preform **102B** has a non-uniform composition in the radial direction. In some other embodiments, preforms can have other non-uniform distributions of fibers.

[0056] **Preform External Architecture.** FIGS. 4-8 depict several preform architectures in addition to the simple linear architecture of preforms **102A** and **102B** of FIGs. 2A/B and 3A/B.

[0057] FIG. 4 depicts preform **402**, which is an open-form, planar, nonlinear preform in accordance with the present invention. Preform **402** is non-linear because it includes one or more bends **420**. Preform **402** is planar because the bends are within the same plane. Each bend **420** can have an angle independently selected from angles in the range of $0^\circ < \text{bend angle } 420 < 180^\circ$.

[0058] A nonlinear preform, such as preform **402**, can be formed by heating a portion of tow-preg above the softening point of the matrix material therein and then bending the tow-preg, such as via an automatic bending tool. After the appropriate number of bends are made, the tow-preg is sized/cut, thereby creating the preform. Methods of fabricating preforms are disclosed in U.S. Apps. SN 15/612,720, and SN 16/600,131, which are incorporated by reference herein.

[0059] FIG. 5 depicts preform **502**, which is a closed-form, planar, nonlinear preform in accordance with the present invention. A closed-form preform typically comprises a single length of sized tow-preg that is bent such that the two ends thereof are situated proximal to one another, defining an enclosed region. In some embodiments, the two ends are tacked together, such as via adhesive or thermal bonding. (Preform **402** is "open form" because the two ends are not proximal to one another and do not define an enclosed region.) Preform **502** is non-linear because it includes four (*i.e.*, one or more) bends **520**. Preform **502** is planar because the bends are within the same plane.

[0060] FIG. 6 depicts preform **602**, which is a combination of preform **402** and preform **502**. Preform **602** is planar and non-linear, and includes both open form and closed form elements. Preform **602** can be fabricated by forming preforms **402** and **502** and then tacking them together.

[0061] Preforms characterized as "closed form," such as preforms **502**, **602**, and **702**, are typically, but not necessarily, further or alternatively characterized as being "open-framework" or "open volume" preforms. In some embodiments, such open-framework preforms are used to fabricate "open-framework" parts, as described later in this disclosure in conjunction with FIGs. 11A through 11E.

[0062] FIG. 7 depicts preform **702**, which is closed form, planar, and non-linear. Although preform **702** includes stacked elements **730**, it is nevertheless considered to be planar because all bends are in the same plane or in parallel planes. Preform **702** includes two instances of element **730**, each of which comprises outer square element **732** and inner square elements **734**.

[0063] FIG. 8 depicts preform **802**, which is an open-form, non-planar, non-linear preform. Preform **802** is considered to be non-planar because at least one bend is out-of-plane with respect to another bend. In particular, bend **842** between segment **840** and segment **844** is in the y-x plane (*i.e.*, the bend creates two segments that fall in the y-x plane) and bend **846** between segment **844** and segment **848** is in the x-z plane. Such planes are defined herein as being "out-of-plane" with respect to one another. As implied above with respect to preform **702**, and as made explicit here, the characterization "out-of-plane" excludes layered or stacked elements that include "bends," wherein such stacked elements are substantially parallel (in parallel planes) to one another.

[0064] In preform **802**, the bends are in planes that are orthogonal to one another. However, in some other embodiments, the bends, while being out-of-plane with respect to

one another, are in planes that are not orthogonal to one another. As disclosed with respect to preform **402** of FIG. 4, the bend angle for each bend may be individually selected. Thus, bend **846** can have any angle greater than 0° and less than 180°.

[0065] Although the preforms depicted in FIGs. 4-8 depict any given bend as being defined by one non-zero vector component (*i.e.*, along the x, y, or z axes and within the x-y, z-x, or y-z planes), in some other embodiments, a bend can be defined by any combination of non-zero x, y, or z vector components.

[0066] In some other embodiments, preforms are non-planar, non-linear, and closed form. Furthermore, non-planar, non-linear preforms can comprise non-planar, non-linear elements and planar, non-linear elements. An example of such a preform is a preform that combines, for instance, preform **502** of FIG. 5 and preform **802** of FIG. 8.

[0067] **Compression Molding in Accordance with the Present Methods.** As previously noted, in accordance with the present teachings, fiber-bundle-based preforms are used to fabricate a part, such as via compression molding. More particularly, in accordance with the present teachings, a part is fabricated by positioning two or more such preforms in a mold cavity, closing and thereby pressurizing the mold cavity, and raising the temperature of the contents of the mold cavity to cause the matrix material to soften to the extent that it flows "*i.e.*, melt flow." Under such applied pressure and temperature, the two or more preforms are consolidated and, after cooling, a finished part results.

[0068] As is well known, compression molding is typically conducted at a pressure of at least about 100 psi. The temperature requirements for the process are a function of the matrix material used. For example, for a matrix comprising a thermoplastic resin, the temperature must meet or exceed the resin's glass transition temperature so that resin can flow, but must remain below its degradation temperature. For a matrix comprising a B-stage thermoset or B-stage ceramic, the matrix material must be sufficiently heated to flow, and also meet or exceed the reaction temperature of the co-reactants.

[0069] As previously noted, in accordance with the present teachings, two or more fiber-bundle-based preforms are placed in a particular arrangement and/or orientation—a "layup"—in the mold cavity. Arrangement/orientation specifics are based, at least in part, on desired overall part properties (*e.g.*, mechanical properties, aesthetics, *etc.*) or the properties of a particular region of a part. During placement in the layup, the preforms retain their manufactured shape; this characteristic facilitates directing the fibers from a particular preform to a particular volumetric region of a part.

[0070] FIGs. 9A and 9B depict female mold half **950** having mold cavity **952**, as well as two exemplary fiber-bundle-based preform layups **958** and **970**, respectively, for use in fabricating fiber-composite part **972** (FIG. 9C) via compression molding.

[0071] Layup **958** depicted in FIG. 9A includes: (i) six linear preforms **954** having a polygonal (square) transverse cross section and arranged in two layers of three preforms each, and (ii) six linear preforms **956** having a circular transverse cross section and arranged in two layers of three preforms each. These two groupings of preforms are oriented orthogonally to one another, with one end of each of preforms **956** abutting the side of two of the stacked preforms **954**.

[0072] Layup **970** depicted in FIG. 9B is a more complex arrangement than layup **958** and includes: (i) two stacked "L"-shaped (non-linear) preforms **960**, (ii) four linear preforms **962** organized in two layers of two preforms each, (iii) one linear preform **964**, (iv) four linear preforms **966** organized in two layers of two preforms each, and (v) two linear preforms **968** organized in two layers of two preforms each. Preforms **966** and **968** are about one-half the length of preform **964**. Such different layups might be used as a function of the stresses arising in given volumetric regions of a part as a consequence of the forces to which a part is subjected in use.

[0073] In each of the two embodiments depicted, the preforms are arranged in the shape of an "L" to form the layups **958** or **970**, consistent with the shape of mold cavity **952**. In some embodiments, the layups are formed by adding preforms one-by-one to cavity **952**, such that layup is formed within the cavity. In some other embodiments, some or all of the preforms are tacked together forming a "preform charge" prior to placement into cavity **952**. In embodiments in which all preforms are assembled into a preform charge, the layup (which is then synonymous with the preform charge) is assembled and then placed as a single unit into the mold cavity.

[0074] The composition, internal structure, and external architecture of each preform placed in a mold is individually selectable, as appropriate, typically to achieve a desired attribute of a part being fabricated. For example, given a plurality of preforms in a layup, at least one preform can differ from other preforms in the following non-limiting ways:

- different matrix material (*e.g.*, two different thermoplastics, different fillers, *etc.*);
- different fiber type (*e.g.*, carbon fiber vs. glass, *etc.*);
- different fiber volume fraction;

- uniform vs non-uniform distribution of fibers;
- linear vs. non-linear;
- planar vs non-planar.

To the extent that the matrix material differs from one preform to the next in a layup, such different matrix materials must be compatible with one another. In the present context, “**compatible**” means that the different matrix materials will bond to one another.

[0075] **Part Internal Structure.** Selective positioning of fiber-bundle-based preforms that can differ from one another as described above in accordance with embodiments of the invention provides an ability to fabricate a part having different material properties in different regions of the part. This is quite advantageous since, among any other considerations, the in-use loads on a part often vary at different regions of a part, arising in different stress vectors therein. Also, designing for a certain stiffness or desired electrical properties in certain regions of a part is facilitated by the foregoing.

[0076] A part formed in accordance with the present teachings is considered to comprise two or more “sections.” FIG. 10B depicts a longitudinal cross section through a segment of arm **974** of part **972** of FIG. 9C. This segment has two such sections: section **1081** and section **1084**. The various sections of a part adjoin each other to form the part, although such sections are not necessarily discernable as being discrete from one another upon external or internal examination of the part. That is, adjacent sections can be continuous in the sense that there might not be a distinct interface separating one section from an adjacent section. This will occur, for example, when the matrix material in adjacent sections is the same and the fibers in the adjacent sections are the same. Regardless of whether an interface is readily discernable or not, the notion of a “section” is useful for pedagogical purposes, and is used herein to refer to a volume (of a part) having a uniform composition. That is, a transverse cross-section taken anywhere along the length of a given section will exhibit substantially the same fiber and matrix composition/distribution/alignment.

[0077] In accordance with the present teachings, each section includes at least one “portion.” Referring again to FIG. 10B, section **1081** is composed of portions **1082A**, **1082B**, and **1082C**, and section **1084** is composed of portions **1086A**, **1086B**, and **1086C**. A “portion” refers to a volume of a part derived from a particular preform. That is, a preform is the source of the fibers and matrix material for a given portion. Thus, for example, if a section is derived from two preforms, that section is considered to contain two

portions. Similarly, if a section is derived from three preforms, that section is considered to contain three portions, and so forth. In such embodiments, the composition of each portion of a section is therefore determined by the composition of the preforms from which the section is derived.

[0078] As will be appreciated by comparison of FIG. 10A and FIG. 10B, there is not necessarily a one-to-one correspondence between preforms and portions. FIG. 10A depicts a segment of layup **970** of FIG. 9B. The preforms in the segment are the source of some of the fiber and matrix material that form arm **974** of part **972**. This segment of the layup includes preform **964**, two stacked preforms **968**, and two stacked preforms **966**. Preform **964** is disposed on top of the preforms **966** and **968**. Preforms **964** and **968** comprise first fiber type **1078** and preforms **966** include second fiber type **1082**. In this example, all preforms are assumed to comprise the same matrix material **1080**. In some other embodiments, the matrix material from different preforms—and in different portions—can differ, as long as the matrix materials are compatible with one another. It is notable that the scale (thickness, in particular) of FIG. 10B is enlarged in comparison to FIG. 10A.

[0079] Co-aligned fibers **1078** from preform **964** appear in both portion **1082A** of section **1081** and in portion **1086A** of section **1084**. Still referring to section **1081**, co-aligned fibers **1078** from “upper” preform **968** appear in portion **1082B** and co-aligned fibers **1078** from “lower” preform **968** appear in portion **1082C**.

[0080] And in section **1084**, co-aligned fibers **1082** from “upper” preform **966** appear in portion **1086B** and co-aligned fibers **1082** from “lower” preform **966** appear in portion **1086C**. The matrix is continuous throughout sections **1081** and **1084**.

[0081] As is clear from FIGs. 10A and 10B, the length of each portion of a section does not necessarily correspond to the length of preform contributing fibers to that section (compare the length of portion **1082A** of section **1081** with the length of preform **964**). Furthermore, neither the thickness nor the width of a preform will necessarily correspond to the thickness or the width of a portion. The shape of a portion will, however, be influenced by the shape of the preform. Similar to the situation for “sections,” the interface between adjacent “portions” might or might not be discernable.

[0082] A section can have the same composition or a different composition as an adjoining section. Regarding the latter situation, from section to section, the compositions can vary in terms of the matrix material composition, the fiber composition, content, and/or

fiber distribution, as well as in any other compositional variable(s). Furthermore, adjoining sections can have the same or different fiber alignment.

[0083] The composition of section **1081** differs from that of section **1084**. In particular, whereas portions **1082B** and **1082C** of section **1081** include fibers **1078**, portions **1086B** and **1086C** of section **1084** include fibers **1082**. This is further evidenced from FIGs. 10C and 10D, which depict respective transverse cross sections along axis **A-A** and axis **B-B** of FIG. 10B. A transverse cross section taken anywhere in section **1081** will appear as depicted in FIG. 10C. Similarly, a transverse cross section taken anywhere in section **1084** will appear as depicted in FIG. 10D. However, a transverse cross section of the interfacial area between sections **1081** and **1084** may look somewhat different than the transverse cross sections appearing in either FIGs. 10C or 10D.

[0084] It is to be understood that in addition to extending in a "vertical" direction and a "longitudinal" direction as depicted in FIG. 10B, a section can extend in a "transverse" direction as well. In the context of FIG. 10B, this would, for example, include additional portions adjacent to portions **1082A**, **1082B**, **1082C**, and extending "into the page." This is depicted with more particularity in FIG. 10E.

[0085] FIG. 10E depicts an "exploded" view, by section, of part **972**. The designation of sections is, to some extent, arbitrary, subject to the definition provided above. But the use of "sections" and "portions" as descriptors provides a useful pedagogical tool in conjunction in describing and defining embodiments of the invention, and serve to highlight the differences between parts made in accordance with the present teachings from those in the prior art.

[0086] In the embodiment depicted in FIG. 10E, five "sections" **1081**, **1084**, **1088**, **1092**, and **1098** are defined for part **1072**. Sections **1081** and **1084** have been described in conjunction with FIGs. 9B and 10A-D. FIG. 10E additionally reveals that section **1081** includes portions **1082D** and **1082E** and section **1084** includes portions **1086D** and **1086E**, which portions were not depicted as being included in their respective sections in FIG. 10B. With reference to FIG. 9B, the preforms responsible for at least additional portions **1086D** and **1086E** are readily visible.

[0087] Part **1072** also includes section **1088**, which includes portions **1090A** through **1090D**. Four preforms **962**, which are depicted in FIG. 9B, are the source of material for these portions.

[0088] Sections **1092** and **1096** derive from stacked L-shaped preforms **960** (FIG. 9B). Although the fibers within preforms **960** are assumed to be continuous and co-linear, they give rise to two sections rather than one because the fibers sourced from these preforms and present in arm **974** and arm **976** are oriented orthogonally with respect to one another. Section **1092** includes portions **1094A** and **1094B**, and section **1096** includes portions **1098A** and **1098B**.

[0089] As previously disclosed, the fiber-bundle-based preforms that are the source of material for the various sections/portions of the part can, in accordance with the present teachings:

- (i) be formed, individually, in virtually any desired shape and/or size;
- (ii) vary, individually, in fiber and/or matrix material composition, as well as additives;
- (iii) maintain their shape and fiber orientation when placed in a layup; and
- (iv) be positioned freely and without materials-related limitations (such as tape and sheets) in a layup.

Because of capabilities (i), (iii) and (iv), embodiments of the invention provide a largely unencumbered ability to direct fiber and matrix materials from any given preform to an arbitrary volumetric region of a part being fabricated. Because of capability (ii), embodiments of the invention provide an unprecedented ability to tailor attributes/characteristics of a part. These capabilities, in combination, enable a manufacturer to fabricate fiber-composite parts having desired attributes/characteristics at arbitrary volumetric locations of the part. This should be readily apparent from FIG. 10E.

[0090] In light of the foregoing, it will be appreciated that the methods described herein can be used to fabricate parts having different material properties in: (i) different sections of the part, (ii) different longitudinal portions of a given section of a part, and/or (iii) in different radial/depth locations of a given section of a part.

[0091] For example, with reference to FIGs. 10B-10E, at least some properties of section **1081** can be expected to differ from such properties of section **1084**, due to the presence of different types of fibers in the two sections. And at least some properties of portion **1082B -1082E** of section **1081** are expected to differ from such properties of portions **1086B – 1086E** of section **1084** due to the different fibers in those portions. For example, if fibers **1078** are carbon fiber, and fibers **1082** are fiberglass, the part can be expected to be weaker in portions **1086B – 1086E** than portions **1082A-1082E** and

1086A. Furthermore, because of the continuity of the fibers between sections **1092** and **1096**, as a consequence of the shape of preforms **960**, the region at which the two arms **974** and **976** of part **972** intersect is expected to be stronger near the "outer" corner than the inner corner of the part (since the fibers are not continuous between sections **1088** and **1081**).

[0092] The difference in properties can be functional, such as, for example, by imparting electrical conductivity to one or more sections of a part, such as through the choice of fiber, filler material, or the like. Or the differences can be mechanical, such as, for example, by imparting high mechanical strength to section(s) of a part by appropriate selection of fiber (*e.g.*, carbon fiber, *etc.*) and/or by co-aligning all fiber in such sections, and/or by increasing fiber volume fraction.

[0093] Recalling the discussion of the preform external architecture and internal structure, and in light of the fact that the fiber-bundle-based preforms are the building blocks of parts in accordance with the present teachings, adjoining sections of a part can be colinear or non-colinear, co-planar or non-coplanar, fibers in the adjoining sections can be co-aligned or non-co-aligned, and uniformly or non-uniformly distributed.

[0094] Methods disclose herein, by virtue of the use of fiber-bundle-based preforms, are particularly well suited to fabricating complex parts, including those characterized by open volumes between and/or within solid sections of the part. FIGs. 11A through 11E depict non-limiting examples of open-framework parts (*i.e.*, parts having open volumes).

[0095] FIG. 11A depicts frame **1100**, having open central region **1102**. FIG. 11B depicts lattice **1110** including open volumes **1112**. FIG. 11C depicts lattice **1120** including open volumes **1122**. FIG. 11D depicts truss **1130** having opening volumes **1132**. And FIG. 11E depicts honeycomb **1140** including open volumes **1142**.

[0096] It is to be understood that the disclosure describes a few embodiments and that many variations of the invention can easily be devised by those skilled in the art after reading this disclosure and that the scope of the present invention is to be determined by the following claims.

What is claimed:

- 1.** A method for fabricating a fiber-composite part, wherein the method comprises:
forming a layup, wherein the layup includes a first fiber-bundle-based preform and a second fiber-bundle based preform, and wherein:

 - (a) the first preform is rigid, has a first shape, and comprises a first plurality of continuous, co-aligned fibers impregnated with a first matrix material,
 - (b) the second preform is rigid, has a second shape, and comprises a second plurality of continuous, co-aligned fibers impregnated with a second matrix material; and

consolidating the first preform and the second preform in a mold cavity via the application of heat and pressure; and
cooling the consolidated first preform and second preform, thereby providing a fiber-composite part.
- 2.** The method of claim 1 wherein the first shape and the second shape are individually defined by one or more non-contradictory characteristics from the group consisting of linear, non-linear, planar, non-planar, open form, and closed form.
- 3.** The method of claim 1 wherein the first shape includes a first bend and a second bend.
- 4.** The method of claim 3 wherein the first bend and the second bend are out-of-plane with respect to one another, the first preform therefore characterized as non-planar.
- 5.** The method of claim 4 wherein the first bend and the second bend are orthogonal to one another.
- 6.** The method of claim 1 wherein the first matrix material and the second matrix material are different from one another.
- 7.** The method of claim 1 wherein the first preform and the second preform differ from one another in at least one characteristic selected from the group consisting of fiber type, fiber volume fraction, fiber distribution, matrix composition.

8. The method of claim 1 wherein forming a layup further comprises positioning the first and second preforms so that at least a portion of the second preform is adjacent to at least a portion of the first preform.

9. The method of claim 1 wherein the first shape is different from the second shape.

10. The method of claim 1 wherein the fiber-composite part comprises:

- (a) a first section having a first portion, wherein the first portion comprises the first plurality of co-aligned fibers sourced from the first preform;
- (b) a second section having a first portion, wherein the first portion of the second section comprises the second plurality of co-aligned fibers sourced from the second preform;
- (c) wherein the first section and the second section are contiguous; and
- (d) wherein the first section experiences first stresses and the second section experiences second stresses when the fiber composite is in use due to applied forces, the first section being at a first volumetric region of the fiber-composite part and the second section being at a second volumetric region of the fiber-composite part;
- (e) wherein the first and second stresses differ from one another in at least one of direction and magnitude;

and wherein forming the layup further comprises positioning the first preform in the layup so that the first plurality of co-aligned fibers therefrom occupy the first volumetric region, and positioning the second preform in the layup so that the second plurality of co-aligned fibers therefrom occupy the second volumetric region.

11. The method of claim 10 wherein the first plurality of fibers comprise a different material than the second plurality of fibers.

12. The method of claim 10 wherein a fiber volume fraction of the first plurality of fibers in the first preform is different from a fiber volume fraction of the second plurality of fibers in the second preform.

13. The method of claim 10 wherein forming the layup further comprises positioning the first preform and the second preform so that said first and second preforms are not co-linear with respect to one another in the layup.

14. The method of claim 10 wherein forming the layup further comprises positioning the first preform and the second preform so that said first and second preforms are not parallel with respect to one another in the layup.

15. The method of claim 10 wherein forming the layup further comprises positioning the first preform and the second preform so that said first and second preforms are orthogonal with respect to one another in the layup.

16. The method of claim 1 wherein the fiber-composite part comprises:

- (a) a first section having a first portion, wherein the first portion comprises the first plurality of co-aligned fibers sourced from the first preform;
- (b) a second section having a first portion, wherein the first portion of the second section comprises the second plurality of co-aligned fibers sourced from the second preform;
- (c) wherein the first section and the second section are contiguous; and
- (d) wherein by virtue of a difference in at least one characteristic between the first preform and second preform, the first section of the part is relatively more stiff than the second section of the part, the first section being at a first volumetric region of the fiber-composite part and the second section being at a second volumetric region of the fiber-composite part;

and wherein forming the layup further comprises positioning the first preform in the layup so that the first plurality of co-aligned fibers therefrom occupy the first volumetric region, and positioning the second preform in the layup so that the second plurality of co-aligned fibers therefrom occupy the second volumetric region.

17. The method of claim 1 wherein the fiber-composite part comprises:

- (a) a first section having a first portion, wherein the first portion comprises the first plurality of co-aligned fibers sourced from the first preform;
- (b) a second section having a first portion, wherein the first portion of the second section comprises the second plurality of co-aligned fibers sourced from the second preform;
- (c) wherein the first section and the second section are contiguous; and
- (d) wherein by virtue of a difference in at least one characteristic between the first preform and second preform, the first section of the part is relatively more

electrically conductive than the second section of the part, the first section being at a first volumetric region of the fiber-composite part and the second section being at a second volumetric region of the fiber-composite part;

and wherein forming the layup further comprises positioning the first preform in the layup so that the first plurality of co-aligned fibers therefrom occupy the first volumetric region, and positioning the second preform in the layup so that the second plurality of co-aligned fibers therefrom occupy the second volumetric region.

18. The method of claim 1 wherein the fiber-composite part comprises:

- (a) a first section having a first portion, wherein the first portion comprises the first plurality of co-aligned fibers sourced from the first preform;
- (b) a second section having a first portion, wherein the first portion of the second section comprises the second plurality of co-aligned fibers sourced from the second preform;
- (c) wherein the first section and the second section are contiguous; and
- (d) wherein by virtue of a difference in at least one characteristic between the first preform and second preform, the first section of the part is relatively more thermally conductive than the second section of the part, the first section being at a first volumetric region of the fiber-composite part and the second section being at a second volumetric region of the fiber-composite part;

and wherein forming the layup further comprises positioning the first preform in the layup so that the first plurality of co-aligned fibers therefrom occupy the first volumetric region, and positioning the second preform in the layup so that the second plurality of co-aligned fibers therefrom occupy the second volumetric region.

19. A method for fabricating a fiber-composite part, wherein the method comprises:

forming a layup, wherein the layup includes a first fiber-bundle-based preform and a second fiber-bundle based preform, and wherein:

- (a) the first preform is rigid, has a first shape that is non-planar wherein the first shape includes two bends that are out-of-plane with respect to one another, and comprises a first plurality of continuous fibers impregnated with a thermoplastic resin matrix,
- (b) the second preform is rigid, has a second shape, and comprises a second plurality of continuous fibers impregnated with the thermoplastic resin matrix; and consolidating the first preform and the second preform in a mold cavity via the

application of heat and pressure; and

cooling the consolidated first preform and second preform, thereby providing a fiber-composite part.

20. The method of claim 19 wherein forming a layup further comprises placing the first and second preforms in a mold cavity.

21. The method of claim 19 wherein forming a layup further comprises positioning the first preform in the layup such that the first plurality of continuous fibers from the first preform occupies a first volumetric region of the fiber-composite part, and wherein the first volumetric region experiences first stresses when the fiber-composite part is in use, and wherein the method further comprises:

fabricating the first preform to include an appropriate fiber type, fiber volume fraction, and/or fiber distribution to enable the first volumetric region to withstand the first stresses.

22. The method of claim 21 wherein forming a layup further comprises positioning the second preform in the layup such that the second plurality of continuous fibers from the second preform occupies a second volumetric region of the fiber-composite part, and wherein the second volumetric region experiences second stresses when the fiber-composite part is in use and which differ from the first stresses, and wherein the method further comprises:

fabricating the second preform to include an appropriate fiber type, fiber volume fraction, and/or fiber distribution to enable the second volumetric region to withstand the second stresses, and wherein at least one of the fiber type, fiber volume fraction, or fiber distribution of the second preform differs from that of the first preform.

23. The method of claim 19 wherein the second shape is different than the first shape.

24. A fiber-composite part comprising:

a first section at a first volumetric region of the fiber-composite part, the first section having:

- (a) a first portion, wherein the first portion comprises a first plurality of co-aligned fiber;
- (b) a second portion, wherein the second portion comprises a second plurality of co-aligned fiber;

a second section at a second volumetric region of the fiber-composite part, wherein the first second and the second section are contiguous with one another, the second section having:

- (a) a first portion, wherein the first portion of the second section comprises the first plurality of co-aligned fiber;
- (b) a second portion, wherein the second portion of the second section comprises a third plurality of co-aligned fiber, wherein the second plurality of co-aligned fiber and the third plurality of co-aligned fiber differ from one another in a characteristic selected from the group consisting of fiber type, fiber volume fraction, and fiber distribution.

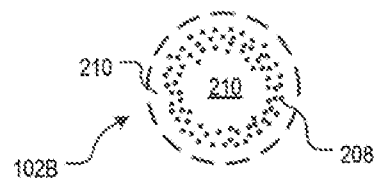
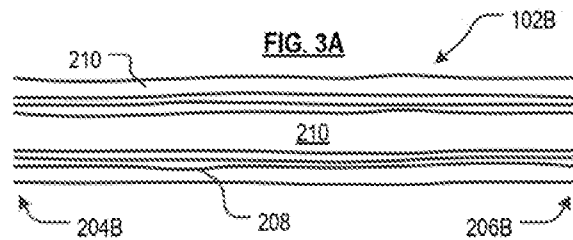
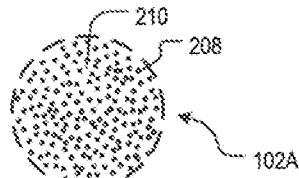
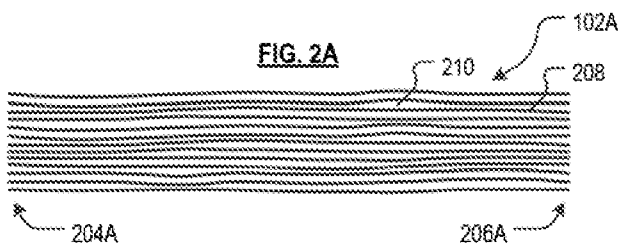
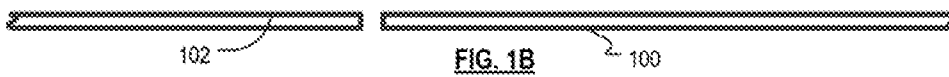
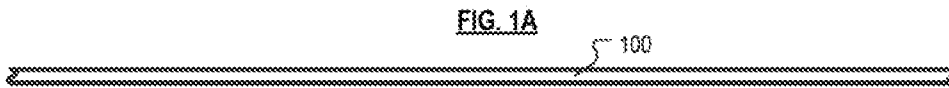

FIG. 4

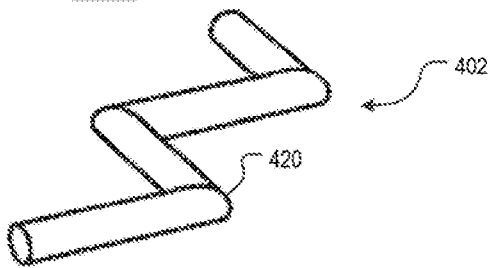

FIG. 5

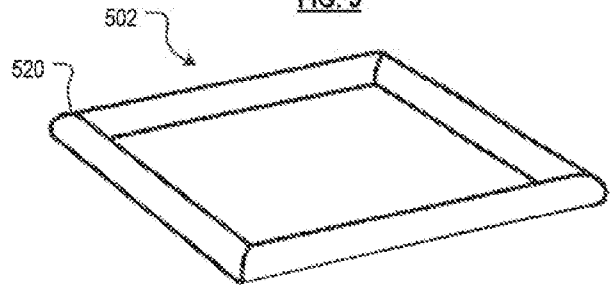
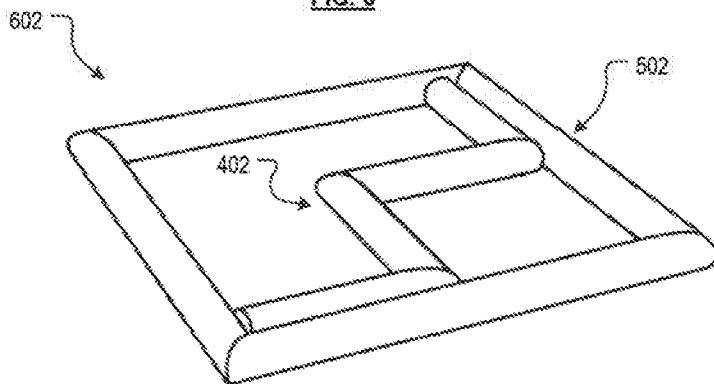
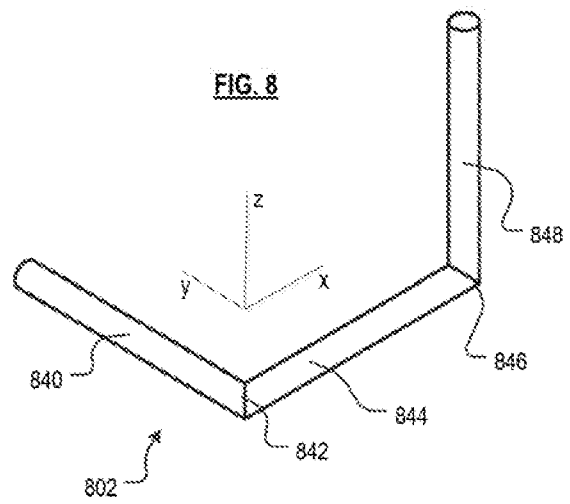
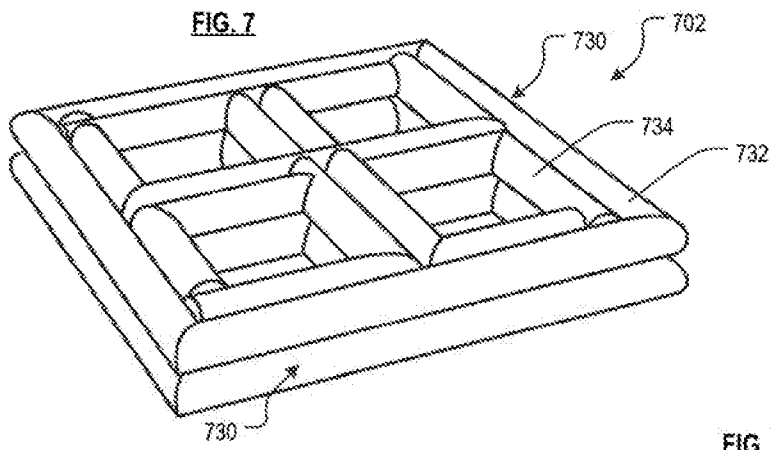

FIG. 6





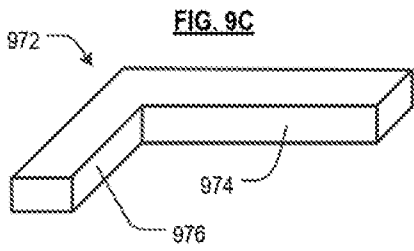
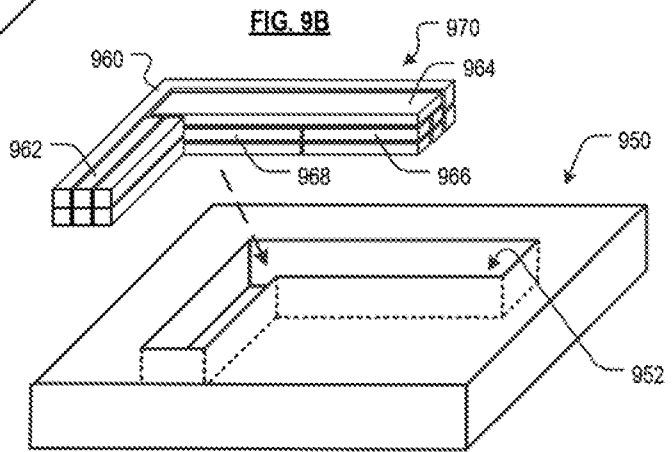
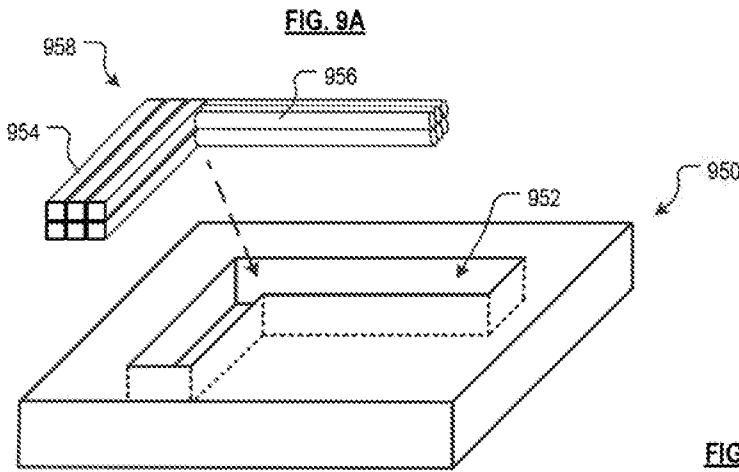

FIG. 10A

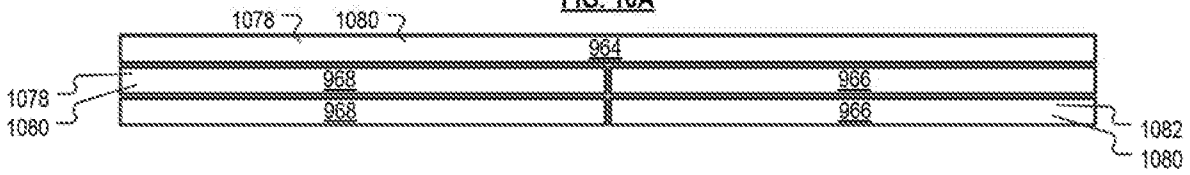

FIG. 10B

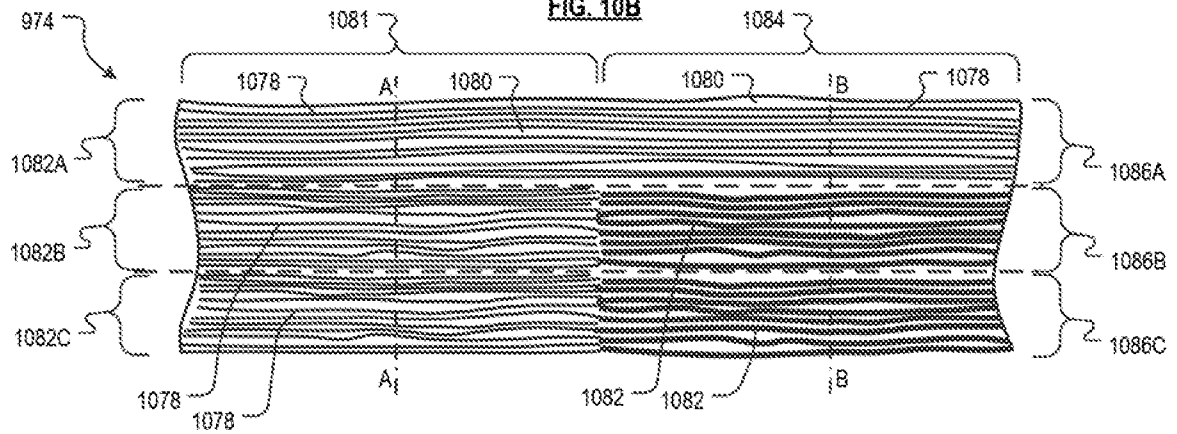

FIG. 10C

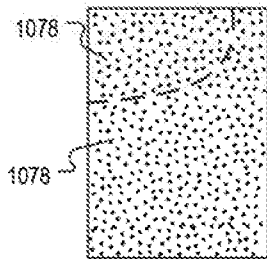
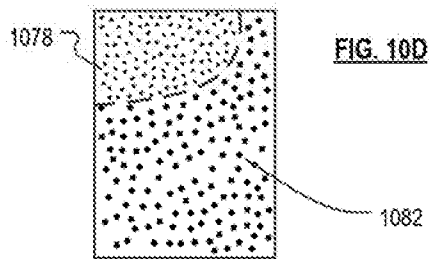

FIG. 10D



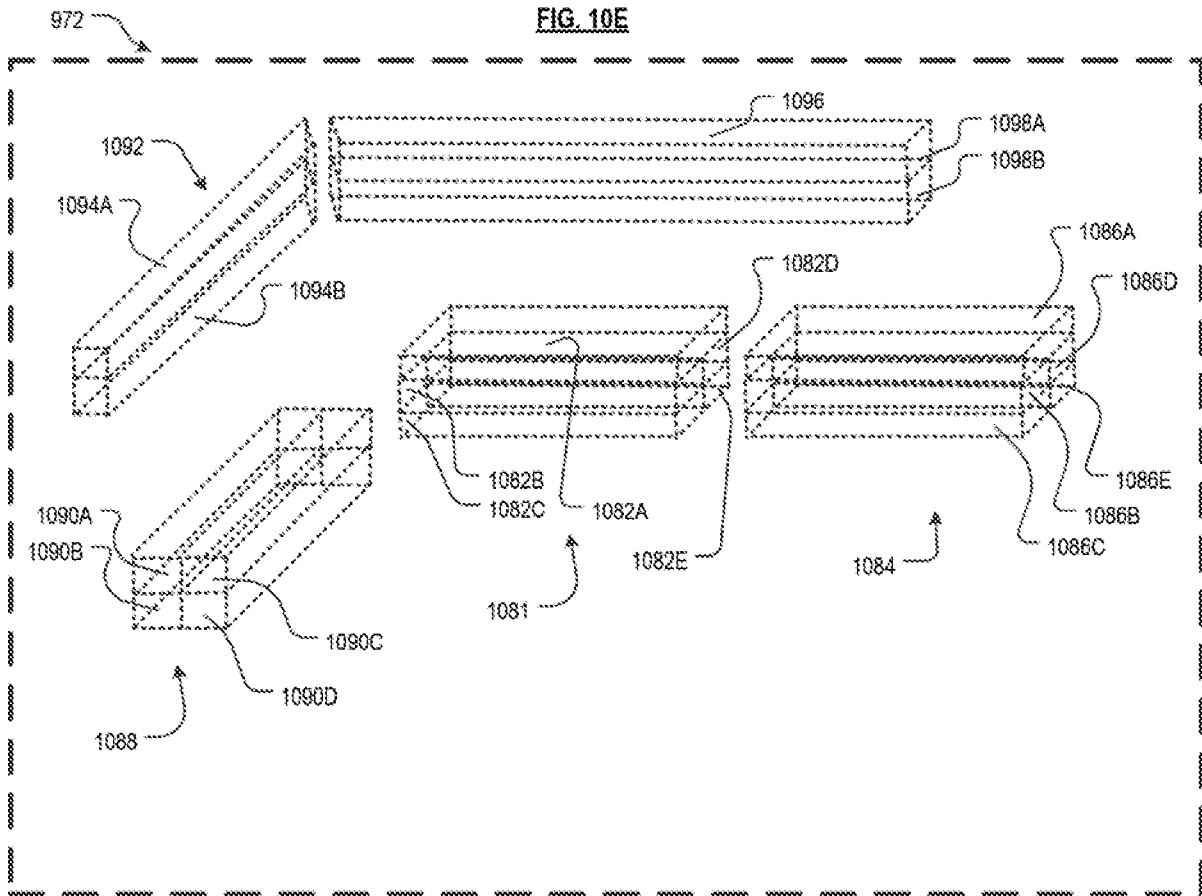

FIG. 11A

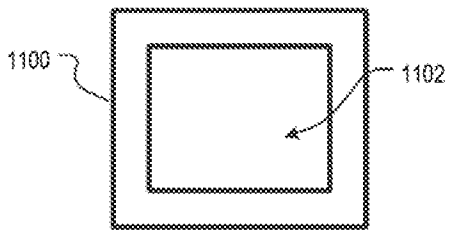

FIG. 11B

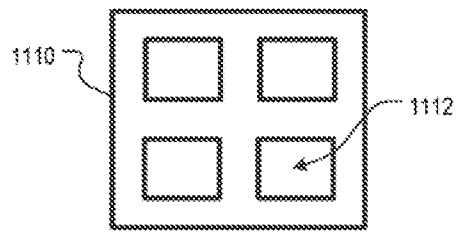

FIG. 11D

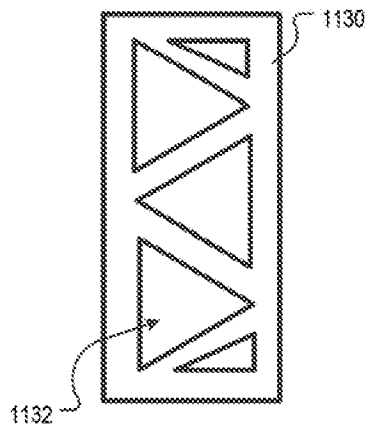

FIG. 11C

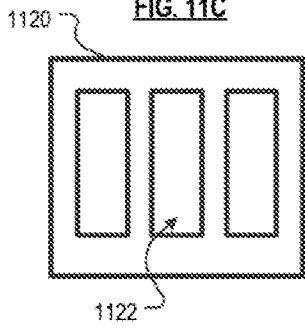
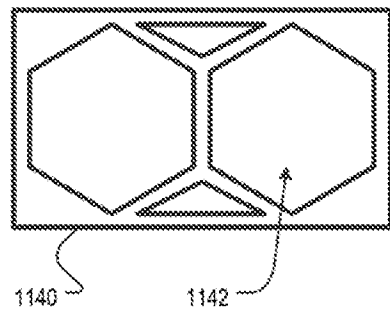

FIG. 11E



INTERNATIONAL SEARCH REPORT

International application No
PCT/US2019/063285

A. CLASSIFICATION OF SUBJECT MATTER
 INV. B29C70/20 B29C70/34 B29C65/00 B29C70/46
 ADD.
 According to International Patent Classification (IPC) or to both national classification and IPC

B. FIELDS SEARCHED
 Minimum documentation searched (classification system followed by classification symbols)
 B29C

Documentation searched other than minimum documentation to the extent that such documents are included in the fields searched

Electronic data base consulted during the international search (name of data base and, where practicable, search terms used)
 EPO-Internal, WPI Data

C. DOCUMENTS CONSIDERED TO BE RELEVANT

Category*	Citation of document, with indication, where appropriate, of the relevant passages	Relevant to claim No.
X	WO 2013/188347 A2 (TICONA LLC [US]) 19 December 2013 (2013-12-19) figures 8, 10 paragraphs [0006], [0035], [0036], [0037], [0054], [0057], [0060] -----	1-3,5,6, 8,10,11, 24
X	US 2006/165955 A1 (RUEGG ANDREAS [CH] ET AL) 27 July 2006 (2006-07-27) figures 8, 9 paragraphs [0041], [0051], [0094] claim 4 -----	1-10, 12-24

Further documents are listed in the continuation of Box C.

See patent family annex.

* Special categories of cited documents :

- "A" document defining the general state of the art which is not considered to be of particular relevance
- "E" earlier application or patent but published on or after the international filing date
- "L" document which may throw doubts on priority claim(s) or which is cited to establish the publication date of another citation or other special reason (as specified)
- "O" document referring to an oral disclosure, use, exhibition or other means
- "P" document published prior to the international filing date but later than the priority date claimed

- "T" later document published after the international filing date or priority date and not in conflict with the application but cited to understand the principle or theory underlying the invention
- "X" document of particular relevance; the claimed invention cannot be considered novel or cannot be considered to involve an inventive step when the document is taken alone
- "Y" document of particular relevance; the claimed invention cannot be considered to involve an inventive step when the document is combined with one or more other such documents, such combination being obvious to a person skilled in the art
- "&" document member of the same patent family

Date of the actual completion of the international search

8 May 2020

Date of mailing of the international search report

19/05/2020

Name and mailing address of the ISA/
 European Patent Office, P.B. 5818 Patentlaan 2
 NL - 2280 HV Rijswijk
 Tel. (+31-70) 340-2040,
 Fax: (+31-70) 340-3016

Authorized officer

Gasner, Benoit

INTERNATIONAL SEARCH REPORT

Information on patent family members

International application No

PCT/US2019/063285

Patent document cited in search report	Publication date	Patent family member(s)	Publication date
WO 2013188347 A2	19-12-2013	US 2013330553 A1	12-12-2013
		WO 2013188347 A2	19-12-2013

US 2006165955 A1	27-07-2006	AU 2003258443 A1	30-04-2004
		CN 1684822 A	19-10-2005
		EP 1581380 A1	05-10-2005
		US 2006165955 A1	27-07-2006
		WO 2004024424 A1	25-03-2004
