



US00D975137S

(12) **United States Design Patent**
Ryder, Jr. et al.

(10) **Patent No.:** **US D975,137 S**
(45) **Date of Patent:** **** Jan. 10, 2023**

- (54) **FRONT COVER FOR AN ENGINE**
- (71) Applicant: **NJR Enterprises, LLC**, Indianapolis, IN (US)
- (72) Inventors: **James L. Ryder, Jr.**, Indianapolis, IN (US); **Nancy A. Ryder**, Indianapolis, IN (US)

2001/0049978 A1* 12/2001 Iwata F16J 15/14
74/606 R
2003/0037754 A1* 2/2003 Neal F02F 7/0073
123/195 C
2006/0150942 A1* 7/2006 Shin F02F 7/008
123/195 C
2013/0068191 A1* 3/2013 Takeuchi F01M 9/10
123/195 R
2014/0020649 A1* 1/2014 Staley F02F 7/00
123/195 R

- (73) Assignee: **NJR ENTERPRISES LLC**, Indianapolis, IN (US)

(Continued)

- (**) Term: **15 Years**

Primary Examiner — Ania Aman

(74) *Attorney, Agent, or Firm* — BrownWinick Law Firm; Christopher A. Proskey

- (21) Appl. No.: **29/831,497**

(57) **CLAIM**

- (22) Filed: **Mar. 21, 2022**

The ornamental design for a front cover for an engine, as shown and described.

- (51) **LOC (14) Cl.** **15-01**

DESCRIPTION

- (52) **U.S. Cl.**

USPC **D15/5**

- (58) **Field of Classification Search**

USPC D15/1, 2, 3, 4, 5, 6

CPC F02F 2007/0075; F02F 7/0073; F02F

7/0021; F02F 2007/0078

See application file for complete search history.

FIG. 1 is a front elevation view of a front cover for an engine;

FIG. 2 is a back elevation view of a front cover for an engine;

FIG. 3 is a top elevation view of a front cover for an engine;

FIG. 4 is a bottom view of a front cover for an engine;

FIG. 5 is a right side view of a front cover for an engine;

FIG. 6 is a left side view of a front cover for an engine;

FIG. 7 is a bottom perspective view of a front cover for an engine;

FIG. 8 is a top perspective view of a front cover for an engine;

FIG. 9 is an additional bottom perspective view of a front cover for an engine; and,

FIG. 10 is an additional top perspective view of a front cover for an engine.

The dashed lines shown depict the environment and represent unclaimed subject matter and form no part of the claimed design.

- (56) **References Cited**

U.S. PATENT DOCUMENTS

6,247,436 B1* 6/2001 Lancefield F02F 7/0073
123/90.38
6,435,154 B1* 8/2002 Simpson F02F 7/0073
123/90.38
6,536,398 B2* 3/2003 Neal F02F 7/0073
123/195 C
7,255,085 B2* 8/2007 Shin F02F 7/008
123/195 C
7,341,038 B1* 3/2008 Forish F02B 77/00
123/195 E
D596,650 S * 7/2009 McClave D15/5
10,578,458 B2* 3/2020 De Boer G01D 5/145
D950,606 S * 5/2022 Murugesan D15/5

1 Claim, 10 Drawing Sheets

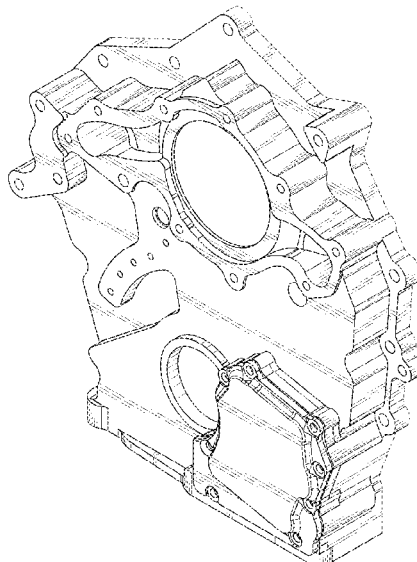

(56)

References Cited

U.S. PATENT DOCUMENTS

2017/0298864 A1* 10/2017 Ito F02F 11/002

* cited by examiner

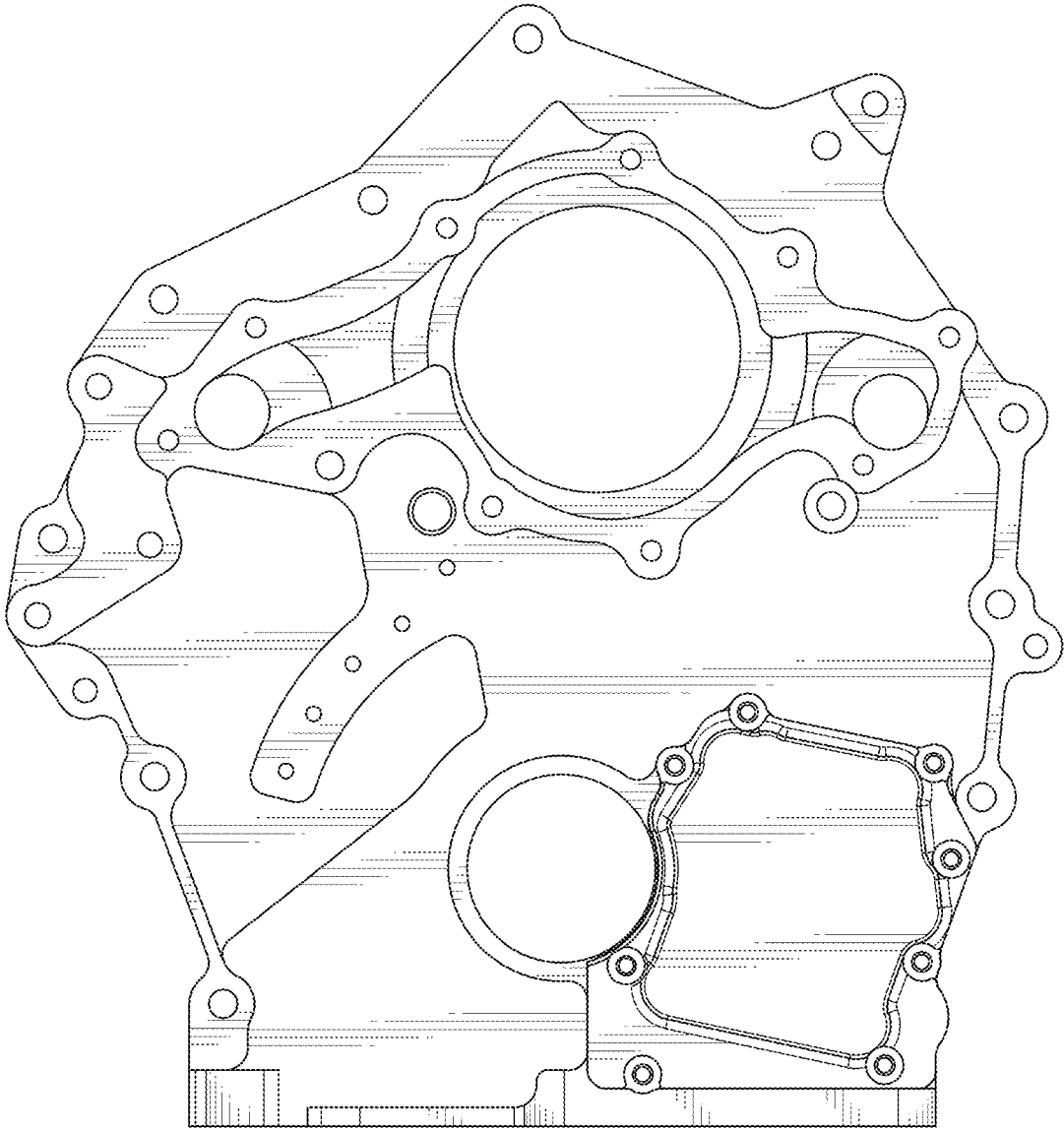

FIG. 1

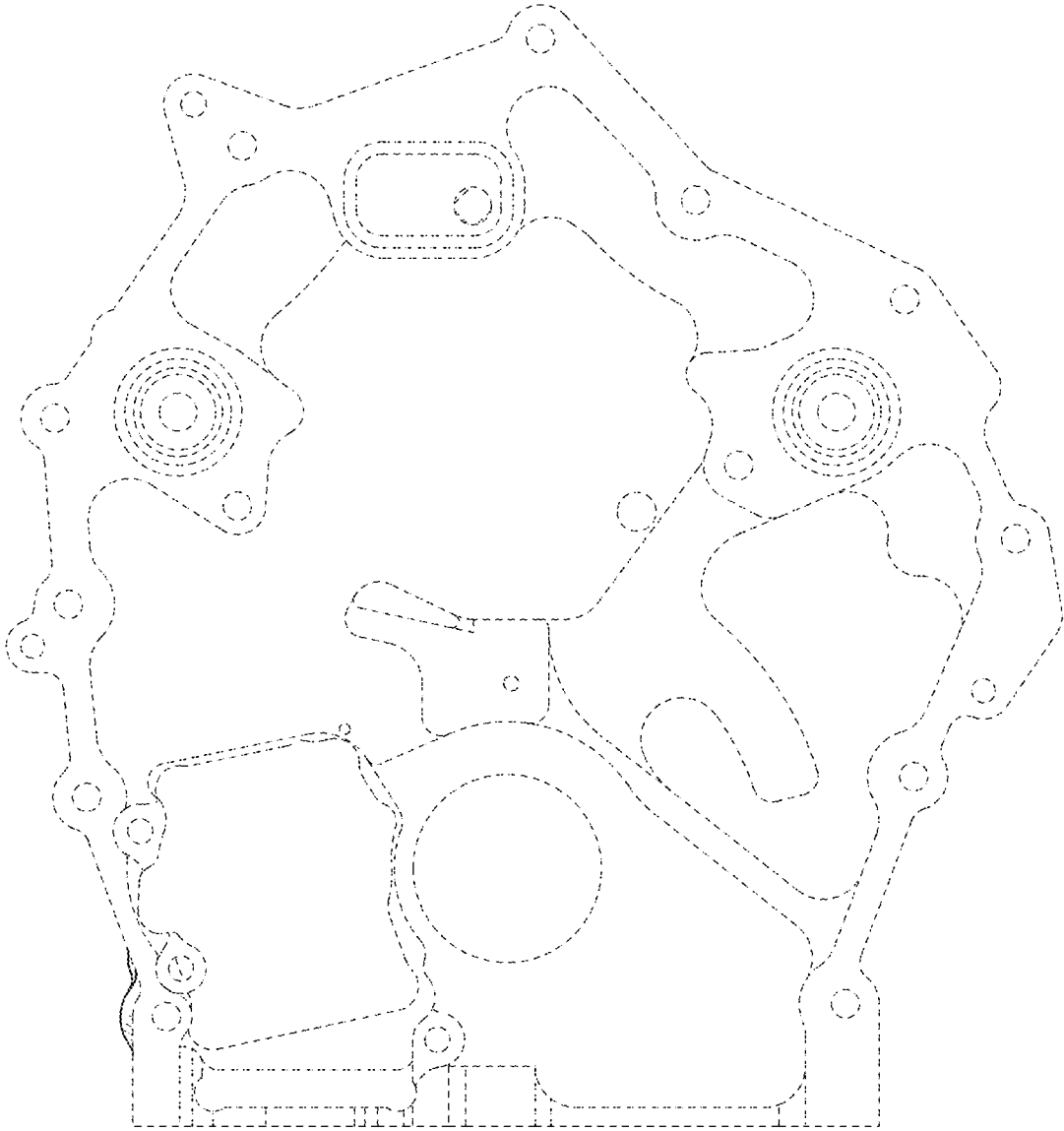

FIG. 2

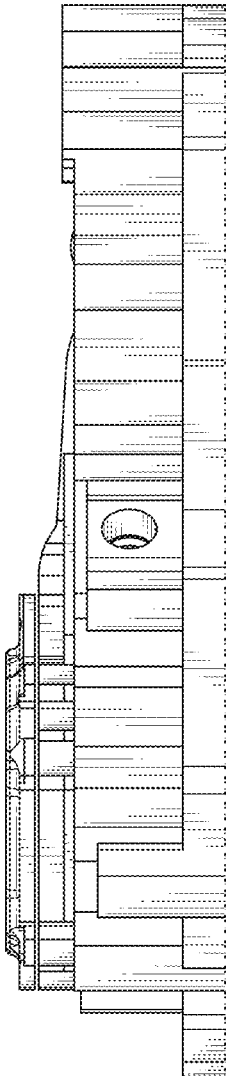

FIG. 3

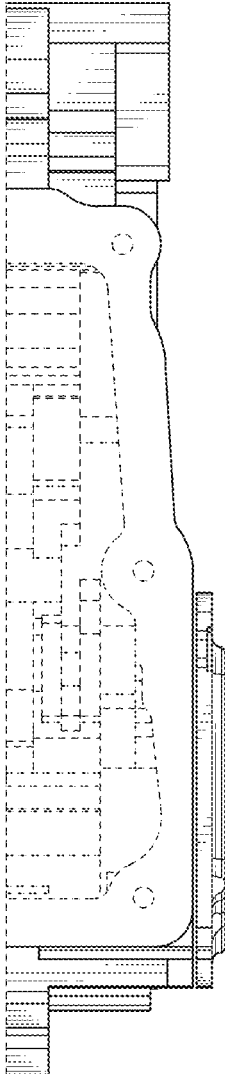

FIG. 4

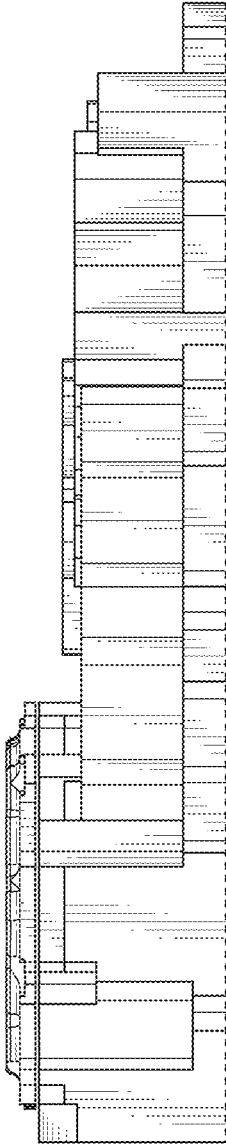

FIG. 5

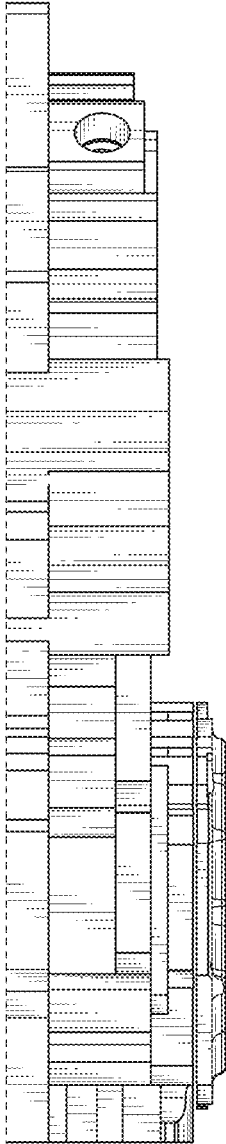

FIG. 6

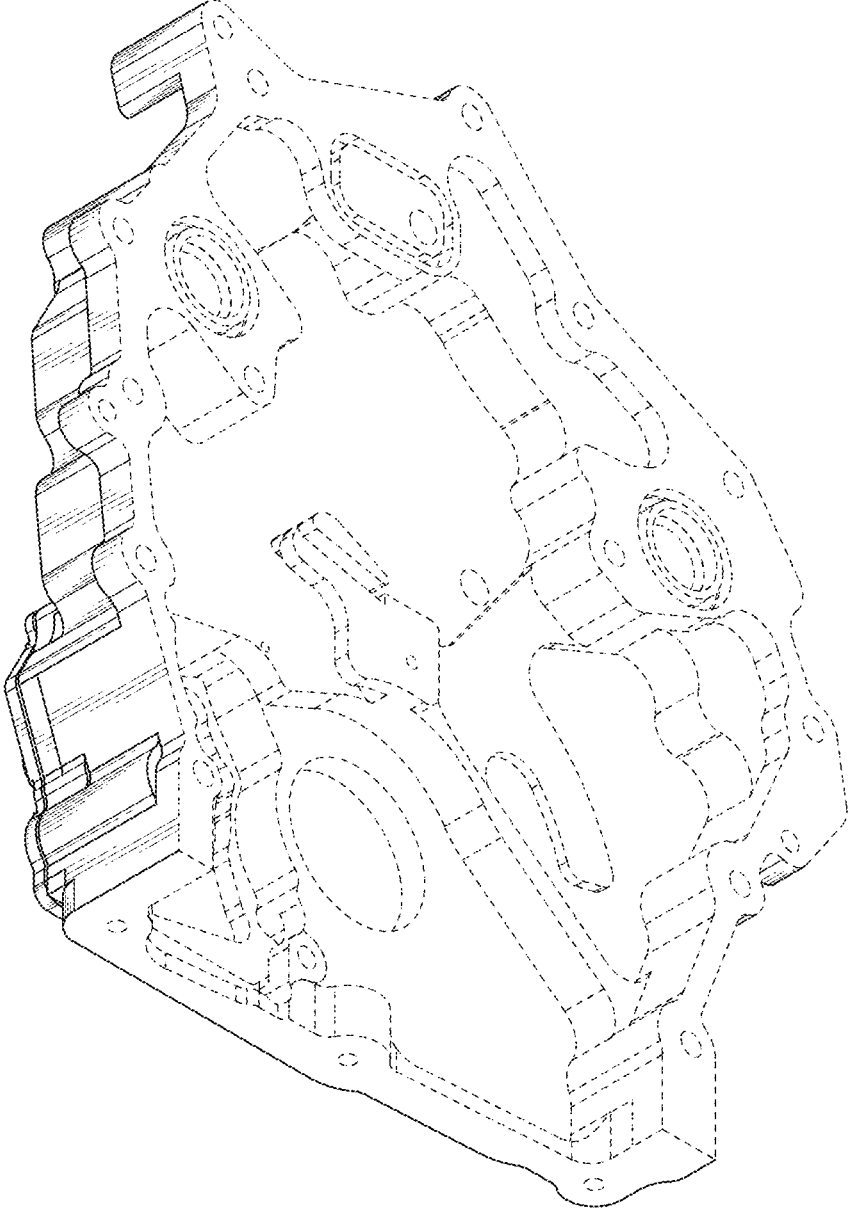

FIG. 7

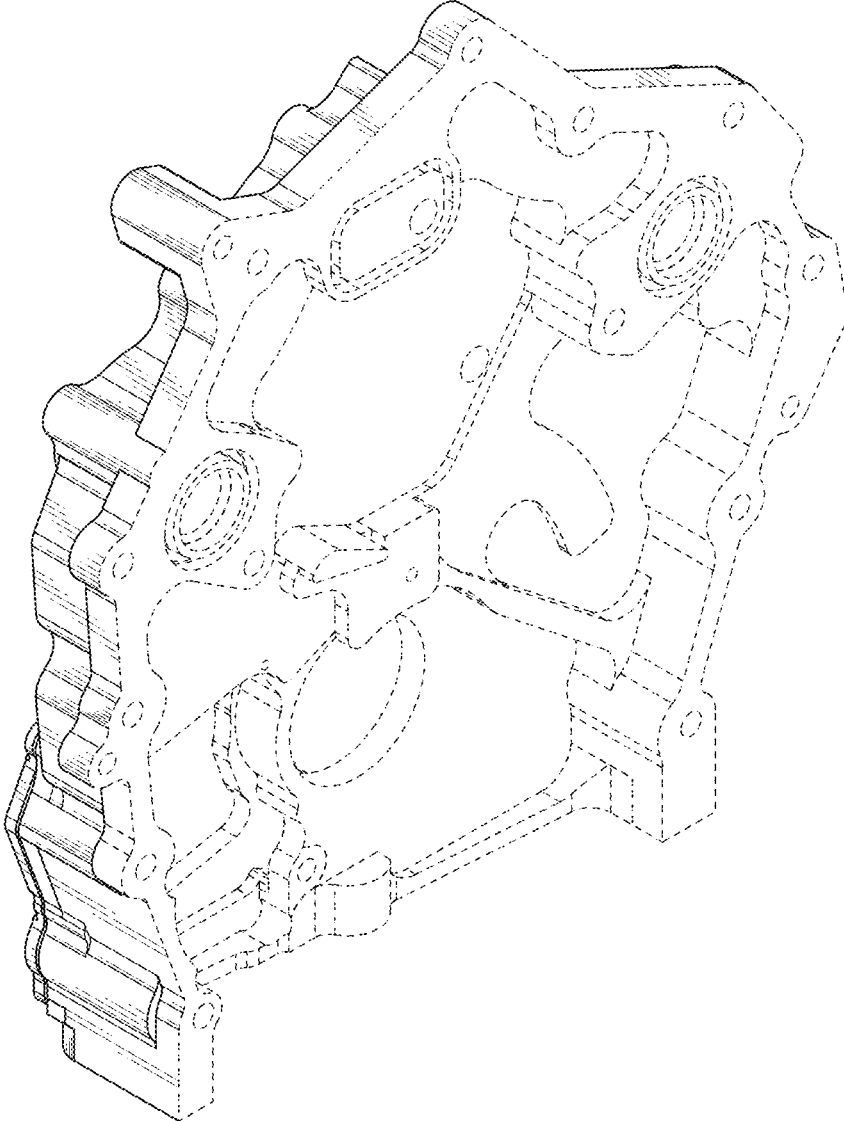

FIG. 8

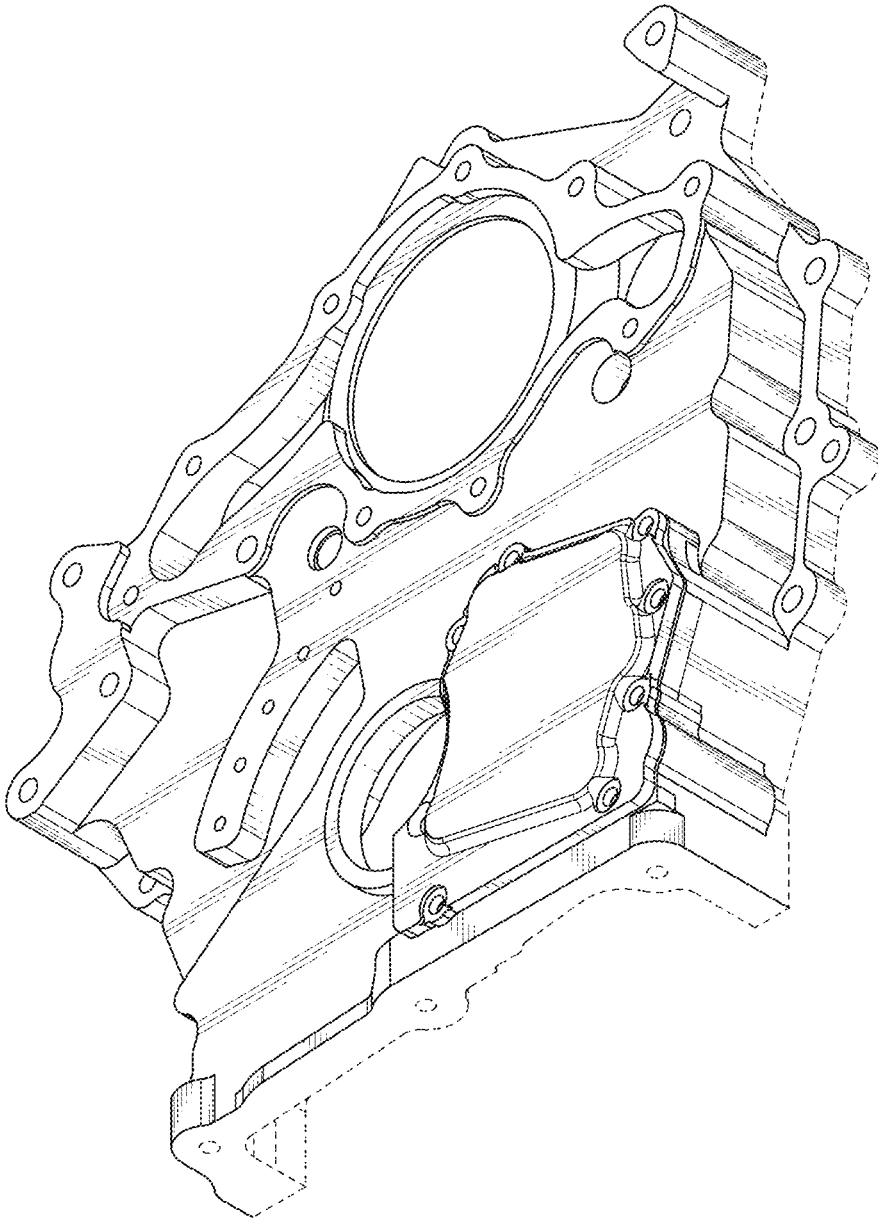

FIG. 9

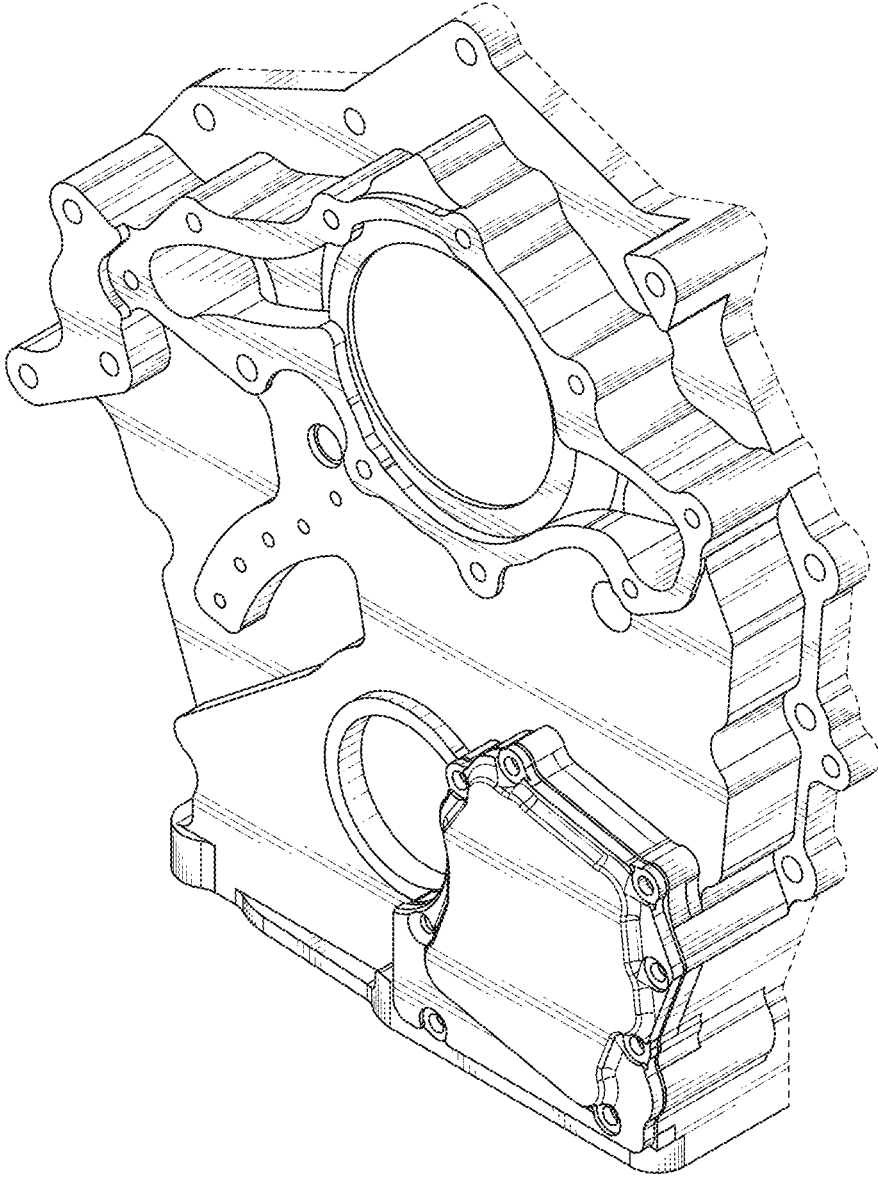

FIG. 10