



INTERNATIONAL APPLICATION PUBLISHED UNDER THE PATENT COOPERATION TREATY (PCT)

<p>(51) International Patent Classification <sup>6</sup> : <b>A61B 17/58</b></p>	<p><b>A1</b></p>	<p>(11) International Publication Number: <b>WO 98/14129</b> (43) International Publication Date: 9 April 1998 (09.04.98)</p>
--	------------------	---

(21) International Application Number: PCT/US97/08997  
(22) International Filing Date: 28 May 1997 (28.05.97)  
(30) Priority Data:  
08/723,800 30 September 1996 (30.09.96) US

(81) Designated States: JP, European patent (AT, BE, CH, DE, DK, ES, FI, FR, GB, GR, IE, IT, LU, MC, NL, PT, SE).

**Published**  
*With international search report.*

(71) Applicant: MINNESOTA MINING AND MANUFACTURING COMPANY [US/US]; 3M Center, P.O. Box 33427, Saint Paul, MN 55133-3427 (US).

(72) Inventors: PITZEN, James, F.; P.O. Box 33427, Saint Paul, MN 55133-3427 (US). DURST, Tim, J.; P.O. Box 33427, Saint Paul, MN 55133-3427 (US). BARTINGALE, Steven, R.; P.O. Box 33427, Saint Paul, MN 55133-3427 (US). CHOWDHERY, Noreen, A.; P.O. Box 33427, Saint Paul, MN 55133-3427 (US). HAGEN, Kathy, L.; P.O. Box 33427, Saint Paul, MN 55133-3427 (US).

(74) Agents: HOHENSHELL, Jeffrey, J. et al.; Minnesota Mining and Manufacturing Company, Office of Intellectual Property Counsel, P.O. Box 33427, Saint Paul, MN 55133-3427 (US).

(54) Title: POWERED SURGICAL INSTRUMENTS AND CONTROL UNIT

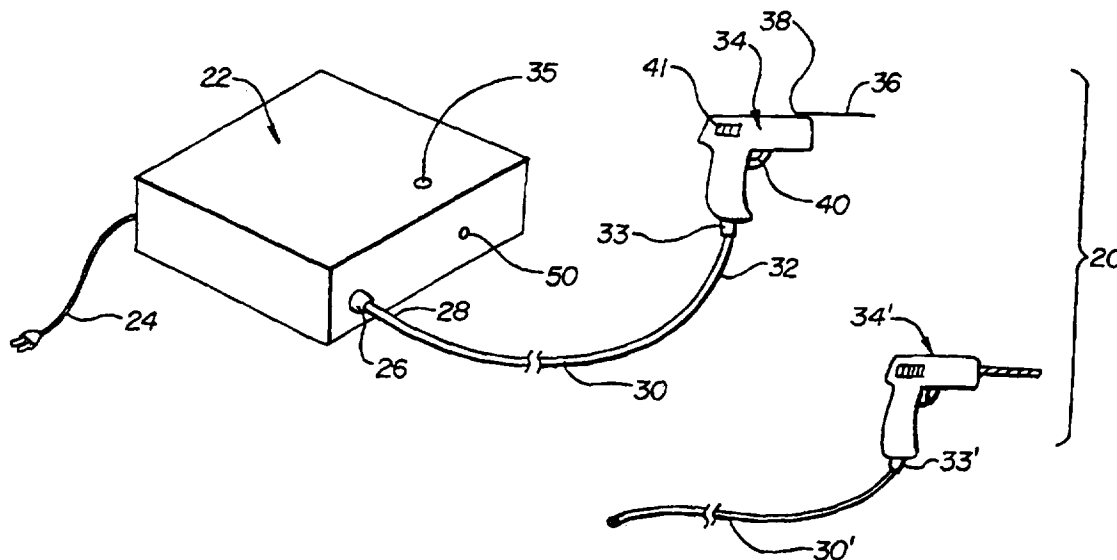

(57) Abstract

An electrically powered surgical instrument system includes a single universal console capable of serving a wide range of surgical tools interchangeably. Each tool when connected to the console communicates its own individual operating parameters to the console, and the console acts to power the tool within those parameters under the direction of the surgeon's commands.

**FOR THE PURPOSES OF INFORMATION ONLY**

Codes used to identify States party to the PCT on the front pages of pamphlets publishing international applications under the PCT.

<b>AL</b>	Albania	<b>ES</b>	Spain	<b>LS</b>	Lesotho	<b>SI</b>	Slovenia
<b>AM</b>	Armenia	<b>FI</b>	Finland	<b>LT</b>	Lithuania	<b>SK</b>	Slovakia
<b>AT</b>	Austria	<b>FR</b>	France	<b>LU</b>	Luxembourg	<b>SN</b>	Senegal
<b>AU</b>	Australia	<b>GA</b>	Gabon	<b>LV</b>	Latvia	<b>SZ</b>	Swaziland
<b>AZ</b>	Azerbaijan	<b>GB</b>	United Kingdom	<b>MC</b>	Monaco	<b>TD</b>	Chad
<b>BA</b>	Bosnia and Herzegovina	<b>GE</b>	Georgia	<b>MD</b>	Republic of Moldova	<b>TG</b>	Togo
<b>BB</b>	Barbados	<b>GH</b>	Ghana	<b>MG</b>	Madagascar	<b>TJ</b>	Tajikistan
<b>BE</b>	Belgium	<b>GN</b>	Guinea	<b>MK</b>	The former Yugoslav Republic of Macedonia	<b>TM</b>	Turkmenistan
<b>BF</b>	Burkina Faso	<b>GR</b>	Greece	<b>ML</b>	Mali	<b>TR</b>	Turkey
<b>BG</b>	Bulgaria	<b>HU</b>	Hungary	<b>MN</b>	Mongolia	<b>TT</b>	Trinidad and Tobago
<b>BJ</b>	Benin	<b>IE</b>	Ireland	<b>MR</b>	Mauritania	<b>UA</b>	Ukraine
<b>BR</b>	Brazil	<b>IL</b>	Israel	<b>MW</b>	Malawi	<b>UG</b>	Uganda
<b>BY</b>	Belarus	<b>IS</b>	Iceland	<b>MX</b>	Mexico	<b>US</b>	United States of America
<b>CA</b>	Canada	<b>IT</b>	Italy	<b>NE</b>	Niger	<b>UZ</b>	Uzbekistan
<b>CF</b>	Central African Republic	<b>JP</b>	Japan	<b>NL</b>	Netherlands	<b>VN</b>	Viet Nam
<b>CG</b>	Congo	<b>KE</b>	Kenya	<b>NO</b>	Norway	<b>YU</b>	Yugoslavia
<b>CH</b>	Switzerland	<b>KG</b>	Kyrgyzstan	<b>NZ</b>	New Zealand	<b>ZW</b>	Zimbabwe
<b>CI</b>	Côte d'Ivoire	<b>KP</b>	Democratic People's Republic of Korea	<b>PL</b>	Poland		
<b>CM</b>	Cameroon	<b>KR</b>	Republic of Korea	<b>PT</b>	Portugal		
<b>CN</b>	China	<b>KZ</b>	Kazakstan	<b>RO</b>	Romania		
<b>CU</b>	Cuba	<b>LC</b>	Saint Lucia	<b>RU</b>	Russian Federation		
<b>CZ</b>	Czech Republic	<b>LI</b>	Liechtenstein	<b>SD</b>	Sudan		
<b>DE</b>	Germany	<b>LK</b>	Sri Lanka	<b>SE</b>	Sweden		
<b>DK</b>	Denmark	<b>LR</b>	Liberia	<b>SG</b>	Singapore		
<b>EE</b>	Estonia						



The use of a dedicated console for each different orthopedic instrument is not without its drawbacks. If several tools (and hence several consoles) are required for a procedure, countertop surface must be provided for them in the crowded operating theater. Also, when tools and cables are returned to the surgical floor after being sterilized, they must be matched up with their corresponding consoles. Further, the console is a significant part of the expense of providing the tool to the surgeon. Thus, this arrangement increases the cost associated with the procedures.

An additional drawback of many prior surgical tool systems is that the tool is operated in an open loop fashion. Thus, if the load on the tool is increased, tool speed drops. This is undesirable.

#### SUMMARY OF THE INVENTION

The present invention arises, in part, from the realization that the art requires a design for instruments which allows a single console to properly control a wide range of tools of different sizes, speed ranges, and power requirements.

The present invention addresses the discussed limitations in the art by providing an electrically powered surgical instrument system wherein a single universal console is capable of serving a wide range of surgical tools. Each tool, when connected to the console, communicates its own individual limitations and requirements to the console, and the console acts to power the tool within those limitations and requirements under the direction of the surgeon's commands.

A first aspect of the present invention includes a surgical instrument system including a console and a plurality of tools connectable to the console. Each tool includes a motor, and the console includes a motor controller connectable to a power supply. The motor controller receives inputs from the tool indicative of operating parameters of the tool and provides tool control outputs which are adapted based on the inputs received from the tool.

In one preferred embodiment, the tool includes a current limit identification circuit which provides a current limit signal to the console. The motor controller controls the current actually being delivered to the tool based on the

current limit signal from the tool to keep the current being delivered by the motor controller within the current limit.

In another preferred embodiment, the tool detects an overspeed condition based on a tool-specific overspeed limit indicative of a maximum speed at which the tool's motor should operate. The tool provides the console with a signal  
5 indicative of the overspeed condition. The motor controller in the console controls the outputs to the tool to turn off the motor.

Another feature of the present invention includes providing the tool with finger actuated triggers so the surgeon can exert control over the tool's speed  
10 by the degree to which the surgeon depresses the trigger. The motor controller detects whether the tool is attached to the console. The motor controller is constructed to deactivate the motor control outputs if the cable is attached to the tool while the trigger is depressed. The outputs are reactivated once the trigger is released and depressed again.

Also, in a preferred embodiment of the present invention the tool  
15 includes a direction switch so that the surgeon can operate the motor on the tool in a forward or reverse direction. Based on inputs from the tool, the motor controller detects when the direction switch is actuated and prohibits the change of direction until the speed of the motor has slowed below a desired level.

20

### BRIEF DESCRIPTION OF THE DRAWINGS

The present invention will be further described with reference to the accompanying drawings wherein like reference numerals refer to like parts in the several views, and wherein:

25 FIG. 1 is a perspective view of an exemplary surgical instrument system according to the present invention;

FIG. 2 is a block diagram of the surgical instrument system of FIG.  
1;

30 FIG. 2A is a more detailed block diagram of a tool shown in FIGS. 1 and 2;

FIG. 2B is a more detailed block diagram of a portion of a console shown in FIGS. 1 and 2;

FIG. 3 is an exemplary schematic diagram of a commutation circuit provided as a part of each tool in the surgical instrument system;

5 FIGS. 4A and 4B are portions of an exemplary schematic diagram of a sensor circuit provided as a part of each tool in the surgical instrument system;

FIGS. 5A and 5B are portions of an exemplary schematic diagram of power conditioning and indicator light control circuit blocks of a motor control circuit according to the present invention; and

10 FIGS. 6A and 6B are portions of an exemplary schematic diagram of additional portions of the motor control circuit according to the present invention, beyond the circuit blocks illustrated in FIGS. 5A and 5B.

## DETAILED DESCRIPTION OF THE PREFERRED EMBODIMENTS

15

### A. OVERVIEW

FIG. 1 illustrates a surgical instrument system 20 in accordance with the present invention. The surgical instrument system 20 includes a console 22, first tool 34 connected to console 22 by a cable 30, and second tool 34' which is connectable to console 22 by a cable 30'. In the preferred embodiment, cables 30 and 30' are substantially identical.

20 Console 22 is provided with a power cord 24 for connection to the house current. Console 22 also includes switch 50 and READY indicator light 35 which indicates when console 22 and tool 34 are in a "ready" operating condition. A console cable connector 26 is provided on the console 22 to permit the console  
25 to be connected to the first end 28 of one of cables 30 and 30'. Second ends 32 and 32' of the cables 30 and 30' are adapted to connect to tool cable connectors 33 and 33'. The depicted tool 34 is an oscillating saw suitable for the removal of bone to prepare for the attachment of joint replacement implants. Tool 34' is a bone drill. However, any number of suitable tools could be included in system 20 and the  
30 remainder of this description proceeds only with respect to tool 34, for the sake of clarity.

Tool 34 includes saw blade 36, tool mount 38, trigger 40 and direction switch 41. The surgeon controls the speed of the oscillating motion of saw blade 36 on tool mount 38 by variable pressure on the trigger 40. Some tools are required by their function to reverse direction at times, and direction control is accomplished on such tools by manipulation of direction switch 41. Console 22 receives motor speed information and direction information from tool 34 and other information regarding the operating parameters of tool 34 via cable 30, and provides motor control signals and power signals to tool 34 via cable 30. Tool 34 is operated according to the present invention in a closed loop fashion. Therefore, if the load on blade 36 increases, more power is fed to the motor in tool 34 to maintain output speed.

FIG. 2 is a block diagram of the overall schematic for surgical instrument system 20 according to the present invention. Console 22 includes a power supply 42, AC power input module 43 and motor controller 44 connected to the power supply by lines 46 and 48. Master power switch So is associated with the power supply 42. The motor controller 44 has motor control outputs 52, 54, and 56, which will be labeled herein 58 collectively, and sensor inputs 60, 62, 64, 66, 68, 70, and 72, which will be labeled herein 76 collectively. All the motor control outputs 58 and the sensor inputs 76 are connected to the console cable connector 26 so that they can be connected via the cable 30 to the tool 34. In the depicted embodiment, shields 90 and 92 are provided to prevent electric fields in the motor control outputs 58 from inducing spurious signals in the sensor inputs 76.

Within the tool 34 is a motor 78, which is conveniently a 3-phase DC brushless motor configured to receive motor control outputs 58 from motor controller 44. Also within the tool 34 is a tool control circuit 80 adapted to provide the sensor inputs 76 to the motor controller 44 via the cable 30. The tool control circuit 80 includes a commutation circuit 82 and a sensor circuit 84. These circuits receive operating power from motor controller 44 via the cable 30 through conductors 86 and 88.

Motor controller 44 also provides a TACH signal indicative of the speed to which motor 78 is being controlled. This is provided to tool control circuit 80 as well, and will be described in greater detail with respect to FIGS. 2A and 2B.

5 Certain conductors are present to provide for communication between the commutation circuit 82 and the sensor circuit 84. Conductors 94 and 96 transmit operating power to the commutation circuit 82, and signals 98 and 100 communicate the status of the direction switch 41 (which is sensed on commutation circuit 82) to sensor circuit 84.

The sensor inputs 76 will now be described with more specificity.  
10 Signals 60, 62, and 64 are provided by the commutation circuit 82 and provide information to the motor controller 44 which is indicative of the commutation state of the motor 78. These signals are preferably generated in part by Hall effect sensors positioned adjacent the motor 78. Signal 66 is an analog signal created by the sensor circuit 84 indicative of the maximum current the particular tool 34 can  
15 tolerate. Signals 68 and 70 encode the position of the direction switch 41 (provided by signals 98 and 100 from commutation circuit 82) as two binary digits. Signals 68 and 70 also encode certain fault conditions, (such as overspeed) and a stop condition. The stop condition is, in one instance, based on a signal received from a sensor which indicates that the trigger 40 is completely undepressed. Signal 72 is  
20 an analog signal created by the sensor circuit 84 which is indicative of the power necessary to drive the particular tool 34 appropriately.

#### B. BLOCK DIAGRAM OF TOOL 34

FIG. 2A is a more detailed block diagram of commutation circuit 82  
25 and sensor circuit 84 in tool 34. Commutation circuit 82 includes Hall sensors 102, 104, 106, 108 and 110. Hall sensors 102, 104 and 106 are arranged about the rotor of motor 78 and provide commutation state signals 60, 62 and 64, back to motor controller 44, which are indicative of the commutation state of motor 78. Hall sensor 106 also provides its output to sensor circuit 84, which will be described in  
30 detail below.

Hall sensors 108 and 110 are arranged relative to direction switch 41 on hand tool 34 to provide signals indicative of the position of direction switch 41. The outputs from Hall sensors 108 and 110 are provided on conductors 98 and 100 to sensor circuit 84. Based on the signals provided by Hall sensors 108 and 110, the forward or reverse setting of direction switch 41 is obtained.

Sensor circuit 84 includes power conditioner 111, current limit identification circuit 113, voltage reduction circuit 115, frequency-to-voltage converter 117, temperature compensator 119, trigger sensor 121, speed command circuit 123, overspeed detector 125, direction and overspeed control circuit -127, and trigger release Hall sensor 134.

Sensor circuit 84 receives the plurality of inputs from the sensors on commutation circuit 82 and provides outputs to motor control circuit 44 indicative of a motor speed requested by hand tool 34, the state of various detectors (such as an overspeed detector) and a current limit signal which indicates the current limit for the specific hand tool 34 being used.

More specifically, power conditioner 111 and voltage reduction circuit 115 receive power along conductors 86 and 88 from motor control circuit 44. Power conditioner 111 conditions the power (such as by filtering) and voltage reduction circuit 124 reduces the voltage levels received by power conditioner 111 to the various voltage levels required on sensor circuit 84. The power is supplied to the remainder of the circuitry in sensor circuit 84, and is also provided to commutation circuit 82 to power the circuitry therein.

Current limit identification circuit 113 is specific to each type of hand tool 34. Current limit identification circuit 113 provides a current limit signal along conductor 66 to motor controller 44. The current limit signal provides an identification of the current limit of the particular hand tool 34 which is being plugged into motor control circuit 44 in console 22. This causes motor control circuit 44 to modify the current level provided to the specific hand tool 34 in response to the current limit signal received.

The TACH signal 74 is provided from motor controller 44' to frequency-to-voltage converter 117 in sensor circuit 84. The TACH signal is an

indication of the present speed of motor 78. Frequency-to-voltage converter 117 converts the pulse train which comprises TACH signal 74 into a voltage output and provides that voltage output to overspeed detector 125 and temperature compensator 119.

5                   It has been observed that, as the temperature of tool 34 increases, the speed of motor 78 varied. This was due to output variation in certain portions of the circuitry in tool 34. In order to accommodate for temperature fluctuations, temperature compensator 119 compensates the voltage received from frequency-to-voltage converter 117 based on the temperature in the environment of sensor circuit  
10 84. The compensated voltage is provided to speed command circuit 123. Speed command circuit 123 compares the compensated voltage signal, which is indicative of the actual speed of motor 78, with a signal received from trigger sensor 121. Trigger sensor 121 senses the position of the trigger relative to its fully depressed and fully released states. If the trigger is fully depressed, the surgeon operating  
15 hand tool 34 desires full output speed. By the same token, if the trigger is fully released, the surgeon is requesting zero output speed. If the trigger is between fully depressed and fully released, the surgeon is requesting an intermediate speed. Based on the position of the trigger, trigger sensor 121 provides an output to speed command circuit 123 indicative of that position. The signal is thus indicative of the  
20 speed requested by the physician.

Speed command circuit 123 compares this signal with the compensated voltage signal from temperature compensator 119 to determine whether the speed of motor 78 should be increased or decreased. Based on this determination, speed command circuit 123 provides a speed command output to  
25 motor controller 44.

The voltage from frequency-to-voltage converter 117 is also provided to overspeed detector 125. Overspeed detector 125 is tool specific and determines whether the speed of motor 78 is in excess of the desired maximum speed of motor 78 for the particular hand tool 34 being used. Overspeed detector  
30 125 outputs a signal indicative of that determination to direction and overspeed control circuit 127. Direction and overspeed control circuit 127 also receives the

TACH signal 74 from motor controller 44, and the Hall sensor signals from Hall sensors 108 and 110 which indicate the position of the direction switch 41.

In addition, trigger release Hall sensor 134 is arranged relative to trigger 40 to sense when it is in a completely undepressed position. Sensor 134 provides a trigger released signal to direction and overspeed control circuit 137 based on the position of trigger 40.

Direction and overspeed control circuit 127 provides, at its output, a pair of code signals 68 and 70 which are used to encode the position of direction switch 41. This indicates whether motor 78 is to be operated in a forward or reverse direction. Also, direction and overspeed control circuit 127 receives the output from overspeed detector 125 and encodes a FAULT signal on outputs 68 and 70 which indicate to motor control circuit 44 that motor 78 should be stopped in response to an overspeed detection.

Further direction and overspeed control circuit 127 encodes a STOPMOTOR signal on outputs 68 and 70 when trigger release Hall sensor 134 indicates that trigger 40 is totally undepressed. This indicates that the surgeon has completely released trigger 40.

Direction and overspeed control circuit 127 also performs another function. If the TACH signal 74 becomes somehow disconnected from motor controller 44, or becomes somehow disabled, it would be interpreted by speed command circuit 123 as if motor 78 had stopped. This would cause speed command circuit 123 to provide a speed command signal to motor controller 44 requesting additional speed. If, in actuality, motor 78 was running, and the TACH signal 74 was simply disabled, this would result in an overspeed condition which would not be detected by overspeed detector 125. Therefore, direction and overspeed control circuit 127 receives TACH signal 74 and also receives an input signal from Hall sensor 106. A pulse train on both signals indicates that motor 78 is operating. If TACH signal 74 is not toggling (indicating no motor activity) and Hall sensor signal 64 from Hall sensor 106 is toggling then direction and overspeed control circuit 127 interprets the incongruousness of the signals as a fault condition and encodes a FAULT signal on the code signals 68 and 70 provided to motor

controller 44. Before issuing a FAULT signal, circuit 127 preferably allows a short time period to elapse to see whether the two signals reconcile, in order to accommodate for circuit delays. If they do not reconcile after the short time period, the FAULT signal is issued.

5

### C. BLOCK DIAGRAM OF MOTOR CONTROLLER 44

FIG. 2B is a more detailed block diagram of motor controller 44. Motor controller 44 includes scaling circuit 129, motor control logic 131, current limiter 133, command logic 135, power control circuit 137, condition and ready indicator 139, and power conditioner 141. FIG. 2B also shows switch 50 and switch ON indicator 51. Motor control circuit 44 receives power on lines 46 and 48 from power supply 42 shown in F-IG. 2. The power is conditioned by power conditioner 141 and provided to the remainder of the circuit. In addition, ON switch 50 is coupled to power conditioner 141 and, when switched ON, provides a signal to switch ON indicator 51 indicating to the physician that the motor controller 44 has been energized.

The speed command signal 72 provided by sensor circuit 84 is provided to scaling circuit 129 where it is scaled to an appropriate level for motor control logic 131. The scaled speed command signal is provided to motor control logic 131, along with the commutation state signals from Hall sensors 102, 101 and 106 via lines 60, 62 and 64. Motor control logic 131 also receives a STOP signal and a FORWARD/REVERSE signal from command logic 135. These signals are decoded from code signals 68 and 70. Motor control logic 131 provides control signals to power control circuit 137 which actually provides the commutation signals 52, 54 and 56 to motor 78. Motor control logic 131 provides the control signals to power control circuit 137 based on the commutation state signals 60, 62 and 64, based on the STOP signal, based on the FORWARD/REVERSE signal, and based on the scaled speed signal from scaling circuit 129.

Motor control logic 131 also receives an input from current limiter 133. Current limiter 133 receives the current limit identification signal 66 from sensor circuit 84 indicating the maximum allowed current associated with the

particular hand tool 34 being used by the physician. Current limiter 133 also receives a current signal from power control circuit 137 which is indicative of the current being provided to motor 78. Current limiter 133 determines whether the current being provided has reached the current limit identified by current limit  
5 identification signal 66 and provides an output signal to motor control logic 131 indicative of that determination. If the current being provided to motor 78 exceeds the current limit for the particular hand tool 34 being used, motor control logic 131 reduces the current being supplied to motor 78.

Motor control logic 131 also provides power control signals 143,  
10 and a tachometer pulse signal 145 to command logic 135. Control signals 143 are used in indirectly controlling power control circuit 137, while tachometer pulse signal 145 forms the basis of TACH signal 74.

Command logic 135 also receives the commutation state signals 60,  
62 and 64 from Hall sensors 102, 104 and 106. In addition, command logic 135  
15 receives the code signals from direction and overspeed control circuit 127 in sensor circuit 84. Command logic 135 senses the states of commutation state signals 60, 62 and 64. One of the signals will be in a low logic state as long as power tool 34 is connected to motor control circuit 44. If all of the lines are in a high logic state, command logic 135 interprets this condition as an indication that no tool is  
20 connected to motor controller 44. Command logic 135 will then not allow power to be provided to motor 78 until a hand tool has been plugged into motor controller 44, and until code signals 68 and 70 provide a STOPMOTOR signal, which indicates that the physician has completely released the trigger. This prevents the hand tool 34 from being plugged into motor 44 and having motor 78 immediately  
25 start running, such as when the physician accidentally has the trigger partially depressed at the time the tool is plugged in.

Command logic 135 also monitors the speed of motor 78 when the direction of motor 78 is to be reversed. Command logic 135 does not allow reverse commutation signals to be provided to motor 78 until the speed of motor 78 has  
30 been reduced to a safe level. Therefore, upon receiving the code signals 68 and 70 which indicate that the direction of motor 78 is to be reversed, command logic 135

turns off power to motor 78 until tachometer pulse signal 145, provided by motor control logic 131, has reached a sufficiently low level indicating that motor 78 is running at a slow speed. Only then will command logic 135 provide control signals to power control circuit 137 allowing reverse commutation signals to be sent to  
5 motor 78.

Command logic 135 also provides signals back to motor control logic 131 for use in controlling power control circuit 137.

Finally, command logic 135 provides outputs to condition and ready indicator 139 which contains a set of indicator lights and READY indicator light 35.  
10 The outputs provided by command logic 135 are indicative of the various fault conditions or running states of motor control circuit 44. Condition and ready indicator 139 may also be other visual or audible indicia observable by the operating physician or by a technician.

#### 15 D. DETAILED IMPLEMENTATION OF TOOL 34

##### 1. Commutation Circuit 82

FIG. 3 illustrates an exemplary schematic diagram of a commutation circuit 82 provided as a part of each tool 34 in the surgical instrument system 20. Hall effect sensors 102, 104, and 106 are positioned about the rotor of motor 78 so  
20 as to detect the commutation state (or the position) of the motor 78 (shown in FIG. 2A) Preferably, the Hall effect sensors are arranged in such a way relative to the rotor that at least one of them is always active, regardless of the position of the rotor.

FIG. 3 also shows a plurality of extra Hall sensor locations 107 and  
25 109. These locations are provided so they can be populated to accommodate various rotor configurations.

Hall effect sensors 108 and 110 monitor the position of the direction switch 41. Sensors 108 and 110 provide signals indicative of the forward or reverse positions of switch 41, respectively. "T" filters 112, 114, and 116 are provided to  
30 dampen electromagnetic (EM) interference on signals 60, 62 and 64, respectively.

## 2. Sensor Circuit 84

FIGS. 4A and 4B are portions of an exemplary schematic diagram of a sensor circuit 84 provided as a part of each tool 34 in the surgical instrument system 20. It is to be noted that the sensor circuit 84 is likely to be slightly different for each tool 34 provided as a part of the surgical instrument system 20. Console 22 is configured to receive the particular requirements communicated by each different sensor circuit 84 and to adapt its outputs to meet those requirements.

In the depicted embodiment, power conditioning circuit block 10 receives +12 volts of DC power via conductors 86 and 88 when the tool 34 is connected to the console 22 via the cable 30. Capacitors 120 and 122 condition this voltage before providing it to voltage reduction circuit 115 which uses a voltage control chip 300 such as the LT1121ACS8-5 commercially available from Linear Technology Corp., located in Milpitas, CA, to provide +5 volts DC. This lower voltage is used elsewhere in the sensor circuit 84, and is also transmitted for use in the commutation circuit 82 by conductors 94 and 96.

Current limit identification circuit 113 is provided, including a voltage divider 126 which is tool-specific. The voltage that voltage divider 126 places on line 66 is indicative of the maximum current the motor 78 in the specific tool 34 can withstand, and is interpreted by the motor control circuit 44 as will be described below with respect to FIGS. 6A and 6B.

The direction and overspeed control circuit 127 has several inputs, and two outputs and includes logic chip 138, Hall sensor 134 and EMI filters (or T filters) 140 and 142. Commutation state signals 60, 62, and 64 are routed, in the embodiment shown in FIG. 4A, through the direction and overspeed control circuit 127 before being routed to the tool cable connector 33. Signal 64 is tapped at line 130 to deliver information to the circuit indicative of whether motor 78 is running. Signals 98 and 100 are provided from commutation circuit 82 and indicate the position of the direction control switch 41. Line 132 conveys the TACH signal 74 which is provided from the motor control circuit 44. Trigger release Hall effect sensor 134 is active only upon total trigger release, and conveys information about

its state via line 136 to logic chip 138. Logic chip 138 is preferably an ATF 16V8BQL chip commercially available from Atmel Corp., located in San Jose, CA.

The primary task of logic chip 138 is to encode the conditions of STARTMOTOR/STOPMOTOR, and FORWARD/REVERSE direction onto two  
5 binary code signals 68 and 70 which are provided to the motor control circuit 44. The STARTMOTOR/STOPMOTOR conditions are encoded on signals 68 and 70 based on the state of the signal provided by Hall sensor 134 which indicates whether the trigger is depressed. The FORWARD/REVERSE conditions are encoded on signals 68 and 70 based on signals 98 and 100 which indicate the  
10 position of switch 41. "T" filters 140 and 142 are provided to suppress EM interference on signals 68 and 70.

Another task is also performed by logic chip 138. Signal 64 on line 130, which is indicative of the presence or absence of actual motor activity, is cross-checked against the TACH signal 74 provided on line 132, which is indicative of the  
15 presence or absence of motor-driving power from the motor control circuit 44. Incongruous signals appearing on these two lines indicate a fault, such as a disconnection of the TACH signal 74. This causes a FAULT state to be generated by logic chip 138 until the fault is corrected. In one preferred embodiment, generation of the FAULT state is maintained and causes motor 78 to be stopped  
20 until the power is cycled.

Logic chip 138 also sets the FAULT state if an overspeed condition is reached. The overspeed signal on line 144, as will be explained with more particularity below, indicates that the motor 78 is being driven at the threshold of its  
25 overspeed limit. The resultant FAULT state generated by logic chip 138 halts the driving energy coming to the motor 78 and forces the motor 78 to coast to a stop.

More specifically, frequency-to-voltage converter circuit 117 is provided to convert the digital TACH signal 74 indicative of motor drive tach into a voltage on line 148. This is accomplished by a frequency-to-voltage converter chip  
30 150 which is preferably a LM 2907 chip commercially available from National Semiconductor Corp., located in Santa Clara, CA. In the depicted arrangement, resistor 152 is tool-specific. The value chosen for this resistor adjusts the output

voltage achieved for a given frequency, and thus adjusts the amount of motor speed variation corresponding to the amount of depression of the tool's trigger 40.

Overspeed detection circuit 125 is provided with the analog voltage via line 148, which line is directed to the negative input of op amp 156. The positive input of op amp 156 is connected to a voltage divider network 158 and to a feedback signal on line 160. The voltage divider network 158 is tool-specific. The voltage that it generates on line 162 is indicative of the overspeed limit for the specific tool 34 in which it is implemented. In operation, in the absence of any analog voltage signal on line 148, the op amp 156 saturates to a logic high level and the overspeed signal on line 144 indicates to logic chip 138 that an overspeed condition is not present. However, when the voltage on line 148 becomes sufficiently high to exceed the overspeed limit signal voltage on line 162, the overspeed signal (the output of op amp 156 on line 144) goes to a logic low level and logic chip 138 reacts to the overspeed condition by causing motor 78 to coast as discussed above.

It has been observed that frequency-to-voltage converter 117 can, in some embodiments, be temperature sensitive. As the temperature increases, the output of converter 117 also increases. This sensitivity causes its output to vary with temperature, variation in the output of converter 117 causes variation in motor speed, which is undesirable. Therefore, temperature compensation circuit 119 is provided in order to compensate for the temperature sensitive nature of the frequency-to-voltage converter 117. A temperature sensor 168, which is preferably a LM 45 chip commercially available from National Semiconductor, is used to sense the ambient temperature in the tool 34. An op amp 170 provides isolation and signal matching for the output of temperature sensor 168 and sums that output with the voltage on line 148 to present a temperature compensated motor tach signal on line 172 to speed command circuit 123.

Speed command circuit 123 also receives an input indicative of speed requested by the surgeon. Trigger sensor circuit 121 is present to set up the operating conditions for a linear Hall effect sensor 166. Sensor 166 senses the degree to which the trigger is depressed and provides an output signal indicative

thereof. The maximum voltage which represents a fully squeezed trigger is set by op amp 176. It is difficult to control the consistency in the strength of the magnets used with the Hall sensor 166, from magnet-to-magnet. Also, it has been observed that the outputs of different Hall sensors 166 can vary (from sensor-to-sensor) with the same magnetic inputs. To address these inconsistencies, the output of op amp 176 is clamped by chip 178, which chip is preferably a SSM2220 commercially available from Analog Devices, located in Norwood, MA. This clamping provides a consistent maximum voltage which represents a fully squeezed trigger. The linear Hall effect sensor 166 is preferably a SS495A1 sensor commercially available from Allegro Microsystems, Inc., located in Worcester, MA.

The particular implementation of Hall sensor 166 in FIG. 4 introduces an offset voltage. Therefore an op amp 180 is provided to compensate for this offset.

The output of the linear Hall effect sensor 166 on line 182 (which indicates what speed level the surgeon is requesting), and the temperature compensated motor tach signal on line 172 (which indicates actual motor speed) are both inputs to speed-command circuit 123. There, the two signals are compared with one another by op amp 186 to generate a speed command signal on line 188. A feedback network 190 is provided to fine tune the closed loop response provided to the motor control circuit 44. A unity gain op amp 192 is provided to improve the output impedance of the signal on line 188, and a "T" filter 194 is provided to suppress EM interference. The error signal (or speed command signal) 72 is then provided to the motor control circuit 44.

### 3. Motor Controller 44

FIGS. 5A and 5B show portions of an exemplary schematic diagram of a portion of the motor control circuit 44 according to the present invention. The power conditioning circuit 141 receives 34 volts DC on lines 46 and 48 from power supply 42 (shown in FIG. 2) and includes voltage converters 198, 200 and 202. Power supply 42 is preferably a 34 volt, 11 amp supply commercially available from Condor DC Power Supplies, Inc., located in Oxnard, CA. Voltage converter chips 198, 200, and 202, which are preferably LM 2574 HUM-ADJ chips from National

Semiconductor, convert the input voltage to the levels needed by the remainder of motor controller 44. Lines 204, 206, and 208 indicate the points where +12V, +5V, and -12V are connected to various points on the schematic of FIG. 6. Lines 210 and 212 are connected to a switch indicator on the front panel of the console  
5 22.

Condition and ready indicator 139 receives a STOP signal 214, a FAULT signal 216, FORWARD signal 218, and a REVERSE signal 220 from command logic 135 shown in FIG. 2B which is described in greater detail with respect to FIGS. 6A and 6B. Those signals activate condition indicating LEDs  
10 214a, 216a, 218a, and 220a respectively, and will be discussed with more particularity in connection with FIGS. 6A and 6B. Ready signal 222 is also provided from command logic 135 and drives connector 224, which in connection with ground line 226 operates READY condition indicator 35 on the front or top panel of the console 22.

15 FIGS. 6A and 6B are portions of an exemplary schematic diagram of the remaining portion of the motor control circuit 44 except for the circuit blocks shown in FIGS. 5A and 5B. The speed command signal 72 from sensor circuit 84 is provided to scaling circuit 129. Speed command signal 72 is scaled for use in motor control circuit 44 by scaling circuit block 129. Voltage divider 230 and op  
20 amp 232 provide these functions.

The scaled speed command signal enters motor control logic circuit 131 on line 236. Motor control logic circuit 131 includes a motor control chip 238. The motor control chip 238 is preferably a UC3625 device, commercially available from Unitrode Corp., located in Merrimack, NH. The motor control chip 238  
25 receives commutation information from commutation state signals 60, 62, and 64 via the cable 30. The motor control chip 238 has three high side output signals provided on lines 240a, 240b, and 240c, and has three low side output signals provided on lines 242a, 242b, and 242c. The low side output lines 242a, 242b, and 242c are connected directly to the power control circuit 137.

30 Power control circuit 137 includes power transistors 246a, 246b, 246c, 248a, 248b, 248c, as well as locations for drivers 250a, 250b, and 250c (only

either driver 250a or drivers 250b or 250c are needed and populated for any given motor controller). Within the power control circuit 137, the low side output lines 242a, 242b, and 242c operate the gates of the three low side power transistors 246a, 246b, and 246c. The gates of the three high side power transistors 248a, 248b, and 248c are driven indirectly, via either high side driver 250a, or high side drivers 250b, and 250c, respectively, in an arrangement known to those skilled in the art. The three high side drivers 250a, 250b, and 250c are controlled only indirectly by the three high side output lines 240a, 240b, and 240c because the information on these lines must first be manipulated so as to conform to the particular drivers (either 250a or 250b and 250c) are being used in tool 34. This manipulation is performed by command logic 135 and typically consists of either inverting or buffering the signals.

Command logic 135 includes programmable logic device 252, clock 248 and reset circuit 262. The programmable logic device 252 is preferably a ATV2500 chip commercially available from Atmel Corp., and requires a clock signal for its operation. A clock signal on line 256 is provided by clock chip 258, preferably a LMC555 chip commercially available from National Semiconductor. The programmable logic device 252 has a reset pin, which is connected on line 260 to power on/reset chip 262, which is preferably a DS1232LP chip commercially available from Dallas Semiconductor Corp., located in Dallas, TX. This arrangement keeps the programmable logic device 252 in a reset state briefly upon the powering up of the surgical instrument system 20, so that the motor is not inadvertently energized in an unsafe way due to transient signals in the programmable logic device before the device settles down to stable operation.

Command logic 135 performs a number of checks prior to allowing motor- 78 to be energized. Three of the pins of programmable logic device 252 are connected to commutation state signals 60, 62 and 64. Because of the physical arrangement of the Hall effect sensors 102, 104 or 106 near the motor 78, at least one of these lines is pulled to a logic low level by the Hall sensors 102, 104 and 106 so long as the tool 34 is connected to the console 22 by the cable 30. If all of

signals 60, 62, and 64 are high, the programmable logic device 252 interprets this as a TOOL NOT CONNECTED condition and takes several precautionary steps.

First, if the programmable logic device 252 detects a change of state from TOOL NOT CONNECTED to TOOL CONNECTED (i.e. if one of signals  
5 60, 62, or 64 suddenly goes to a logic low level when all had been high), device 252 determines whether the STARTMOTOR condition is encoded on lines 68 and 70. If so, this means that tool 34 was plugged in while the trigger was depressed. In order to prevent motor 78 from immediately beginning to run, the programmable logic device 252 sets a lockout condition by activating the STOP signal motor  
10 control chip 238 in motor control logic 131 and does not deactivate the STOP signal to motor control chip 238 until the STOPMOTOR condition is received by signals 68 and 70. Thus, if the surgeon connects the energized cable 30 to the tool 34 while inadvertently pulling the trigger, the tool 34 will not begin moving until the trigger is first released and then pulled again.

15 The programmable logic device 252 also decodes the FORWARD/REVERSE state encoded on lines 68 and 70, and adjusts the FORWARD/REVERSE signal provided to motor control chip 238 in motor control logic 131 so that the motor control chip 238 causes power transistors 246a-246c and 248a-248c to operate motor 78 in the forward or reverse direction as set by the  
20 direction switch 41. If the programmable logic device 252 detects a change of state from FORWARD to REVERSE or vice versa, it first checks the frequency of the TACH PULSE signal received from motor control logic 131 on line 143. If the frequency is above a predetermined level, the programmable logic device 252 sets a lockout condition and does not allow the change of direction until the frequency is  
25 below the predetermined level. Thus if the surgeon changes switch 41 while the motor 78 is running, the direction does not actually reverse until the motor has slowed to a speed which permits the reversal to be accomplished without damage to the tool 34.

The programmable logic device 252 also has output pins which  
30 provide STOP signal 214, FAULT signal 216, FORWARD signal 218, and

REVERSE signal 220 to activate condition indicating LEDS 214a, 216a, 218a, and 220a in condition and ready indicator 139 as discussed above.

Further, a signal representative of the frequency of the output on lines 262a, 262b, and 262c is sent on line 264 to op amp 266, where it undergoes a level shift. The signal is then sent to the sensor circuit 84 as TACH signal 74.

Current limit circuit 133 includes resistor network 270, op amp 272, op amp 278 and differential op amp 280. Current limit circuit 133 is provided to prevent the power control circuit 137 from sending the motor 78 more current than that tool can tolerate. The resistor network 270 is connected into the main energy flow through power transistors 246 and 248 by line 271. The voltage drop across these resistors is representative of the current sent to the motor 78 on motor control outputs (commutation signals) 52, 54 and 56 and can be measured by connecting the two sides of resistor network 270 to differential op amp 272 via lines 274 and 276. At the same time, the tool-specific voltage on line 66 (which identifies the maximum current allowed by the specific tool 34) is connected to op amp 278 for isolation and buffering, and is then provided to differential op amp 280. The output of op amp 272 is directed to the other input of op amp 280, and hence the output of op amp 280 is a comparison of the delivered current to the current limit of the tool 34 presently attached to the cable 30. If the delivered current rises to the current limit, a signal on line 282 signals the motor control chip 238 to reduce the delivered current.

Therefore, the present invention provides significant advantages over the prior art systems. The present invention provides a universal console 22 which can be used with a plurality of different tools 34. Console 22 adapts and configures its outputs to accommodate the specific operating parameters, such as current limit, power requirements, speed control, and any other desirable power requirements, to the specific tool to which it is connected. Further, console 22 takes measures to ensure that the tool 34 is not erroneously powered up in a running state, to ensure that the TACH signal has not become disconnected, and to ensure that certain speed parameters are met prior to reversing the direction of operation of the tool.

The present invention also provides closed loop control and temperature compensation to avoid undesirable variations in output speed.

Various modifications and alterations of the present invention will be apparent to those skilled in the art without departing from the scope and spirit of this invention, and it should be understood that this invention is not limited to the illustrative embodiments set forth herein.

WHAT IS CLAIMED IS:

1. A surgical instrument system, comprising:  
a plurality of surgical tools, each surgical tool operating according to a set  
5 of operating parameters, each surgical tool including a motor; and  
a console including a motor controller providing control output signals, the  
console being interchangeably coupleable to each of the plurality of  
tools;  
wherein each surgical tool is configured to provide operating parameter  
10 information to the console indicative of the set of operating  
parameters associated with each surgical tool; and  
wherein the motor controller is configured to receive the operating  
parameter information from a surgical tool to which it is then  
15 attached and adapt the control output signals based on the operating  
parameter information received.
2. The system of claim 1 wherein the set of operating parameters includes a  
current limit, and wherein the surgical tools are each configured to provide a  
current limit identification signal indicative of the current limit to the console.  
20
3. The system of claim 2 wherein the console comprises:  
a current limit detection circuit coupled to receive the current limit  
identification signal from the surgical tool to which the console is  
attached, and providing a current control output signal indicative of  
25 whether the current being delivered to the motor from the motor  
controller exceeds the current limit identified by the current limit  
signal.
4. The system of claim 3 wherein the motor controller is coupled to the current  
30 limit detection circuit and controls current provided to the motor based on the  
current control output signal.

5. The system of claim 1 wherein each surgical tool includes:  
a motor speed detector detecting motor speed and providing a motor speed  
signal indicative of motor speed; and  
5 an overspeed detector, the overspeed detector providing an overspeed signal  
indicative of whether the motor speed is above a desired level.
6. The system of claim 5 wherein the motor controller is configured to receive  
the overspeed signal and de-energize the motor when the overspeed signal indicates  
10 that the motor speed is above the desired level.
7. The system of claim 1 wherein the motor controller and the surgical tool to  
which it is then adapted being configured to provide closed loop control of the  
motor.  
15
8. The system of claim 1 wherein each surgical tool includes:  
an operator actuatable input providing an actuation signal, the motor  
controller controlling operation of the motor based on the actuation  
signal.  
20
9. The system of claim 8 wherein the motor controller includes:  
a connection detector detecting whether a surgical tool is connected to the  
console and providing a connection signal indicative thereof.
- 25 10. The system of claim 9 wherein the motor controller is configured to control  
operation of the motor based on the connection signal such that the motor  
controller temporarily inhibits operation of the motor when the actuation signal and  
the connection signal indicate that the surgical tool to which the console is then  
attached was connected to the console while the operator actuatable input was  
30 actuated.

11. The system of claim 10 wherein the motor controller is configured to temporarily inhibit operation of the motor when the actuation signal and the connection signal indicate that the surgical tool to which the console is then attached was connected to the console while the operator actuatable input was  
5 actuated, until the operator actuatable input is de-actuated and subsequently re-actuated.

12. The system of claim 8 wherein the motor controller is configured to inhibit operation of the motor upon power-up of the console when the actuation signal  
10 indicates that the operator actuatable input of the surgical tool to which the console is then attached was actuated upon power-up, the motor controller inhibiting operation of the motor until the operator actuatable input is de-actuated and subsequently re-actuated.

13. The system of claim 1 wherein each surgical tool includes:  
an operator actuatable direction input providing a direction signal indicative of  
a desired direction of motor operation;  
wherein the motor controller includes a motor speed detector to detect  
motor speed, the motor controller being configured to control the  
20 motor based on the direction signal to inhibit reversing direction of the motor until the motor speed detector indicates that the motor speed is within a desired limit.

14. The system of claim 8 wherein each surgical tool includes:  
25 a motor activity sensor, coupled to the motor, providing an activity signal indicative of motor activity;  
a speed command circuit, coupled to the operator actuatable input and the motor controller to receive a control output indicative of the speed to which the motor is being controlled, the speed command circuit providing a speed command signal to the motor controller based on  
30 the control output and the actuation signal;

a fault detector, coupled to the motor activity sensor and the motor controller, the fault detector providing a fault signal to the motor controller based on the control output and the activity signal.

- 5 15. The system of claim 14 wherein the fault detector provides the fault signal when the motor activity indicated by the activity signal and the speed indicated by the control output are incongruous.
- 10 16. The system of claim 15 wherein the fault detector provides the fault signal when the motor activity indicated by the activity signal and the speed indicated by the control output are not within a desired range of one another.
- 15 17. The system of claim 8 wherein each tool includes:  
a motor speed indicator providing a motor speed signal indicating a speed to which the motor is being controlled; and  
a speed command circuit coupled to the operator actually input to receive the actuation signal and coupled to the motor speed indicator and providing a speed command signal indicative of a change in motor speed required to control the motor to a speed-indicated by the actuation signal.
- 20
18. The system of claim 17 wherein the tool further comprises:  
a temperature compensator coupled to the motor speed indicator and compensating the speed signal for variations due to temperature changes.
- 25
19. A surgical instrument system, comprising:  
a plurality of surgical tools, each surgical tool including a motor having an operating current limit, and a current limit identification circuit providing a current limit signal indicative of the operating current limit; and
- 30

a console including a motor controller providing control output signals, the console being interchangeably coupleable to each of the plurality of tools;

5 wherein the motor controller is configured to receive the current limit signal from a surgical tool to which it is then attached and adapt the control output signals based on the current limit signal received.

20. A surgical instrument system, comprising:

a surgical tool comprising:

10 a motor;

an operator actuatable speed input providing a requested speed signal indicative of motor speed requested; and

a speed command circuit coupled to the operator actuatable speed input and providing a speed command signal; and

15 a console, disconnectably coupled to the surgical tool, the console comprising:

a motor controller providing commutation signals to the motor based on the speed command signal and providing a tachometer signal indicative of a speed to which the motor is  
20 being controlled;

wherein the speed command circuit provides the speed command signal based on the requested speed signal and the tachometer signal; and

25 wherein the surgical tool further includes a motor activity sensor sensing motor activity and providing an activity signal indicative of motor activity, the surgical tool being configured to provide a fault signal to the motor controller when the motor activity indicated by the activity signal is inconsistent with the tachometer signal.

21. The system of claim 20 wherein the motor controller is configured to inhibit  
30 motor operation based on the fault signal.

22. The system of claim 20 wherein the surgical tool is configured to provide operating parameter information to the console indicative of at least one operating parameter associated with surgical tool, and wherein the motor controller is configured to receive the operating parameter information from the surgical
- 5 tool and adapt the commutation signals based on the operating parameter information received.

1/11

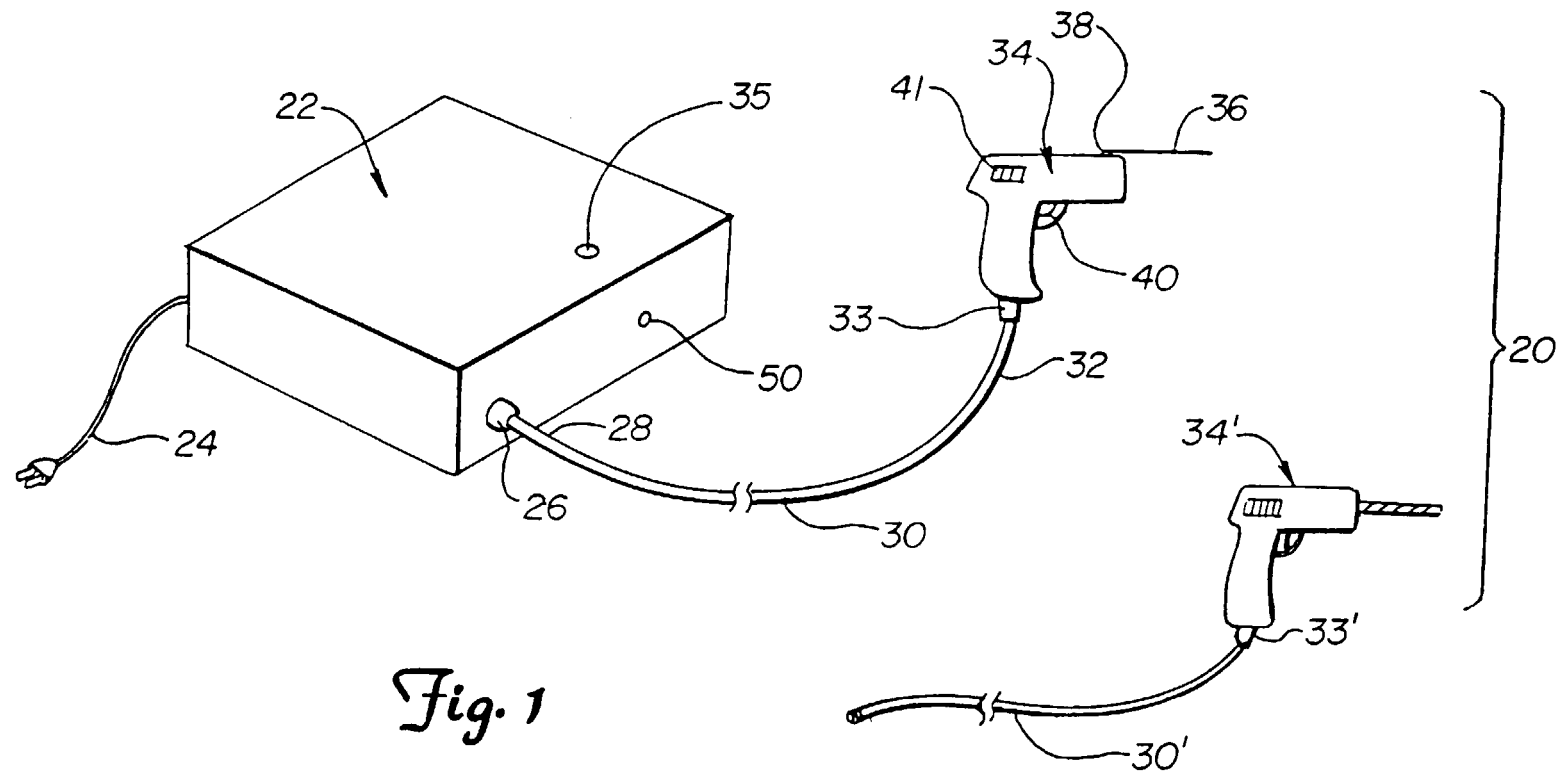

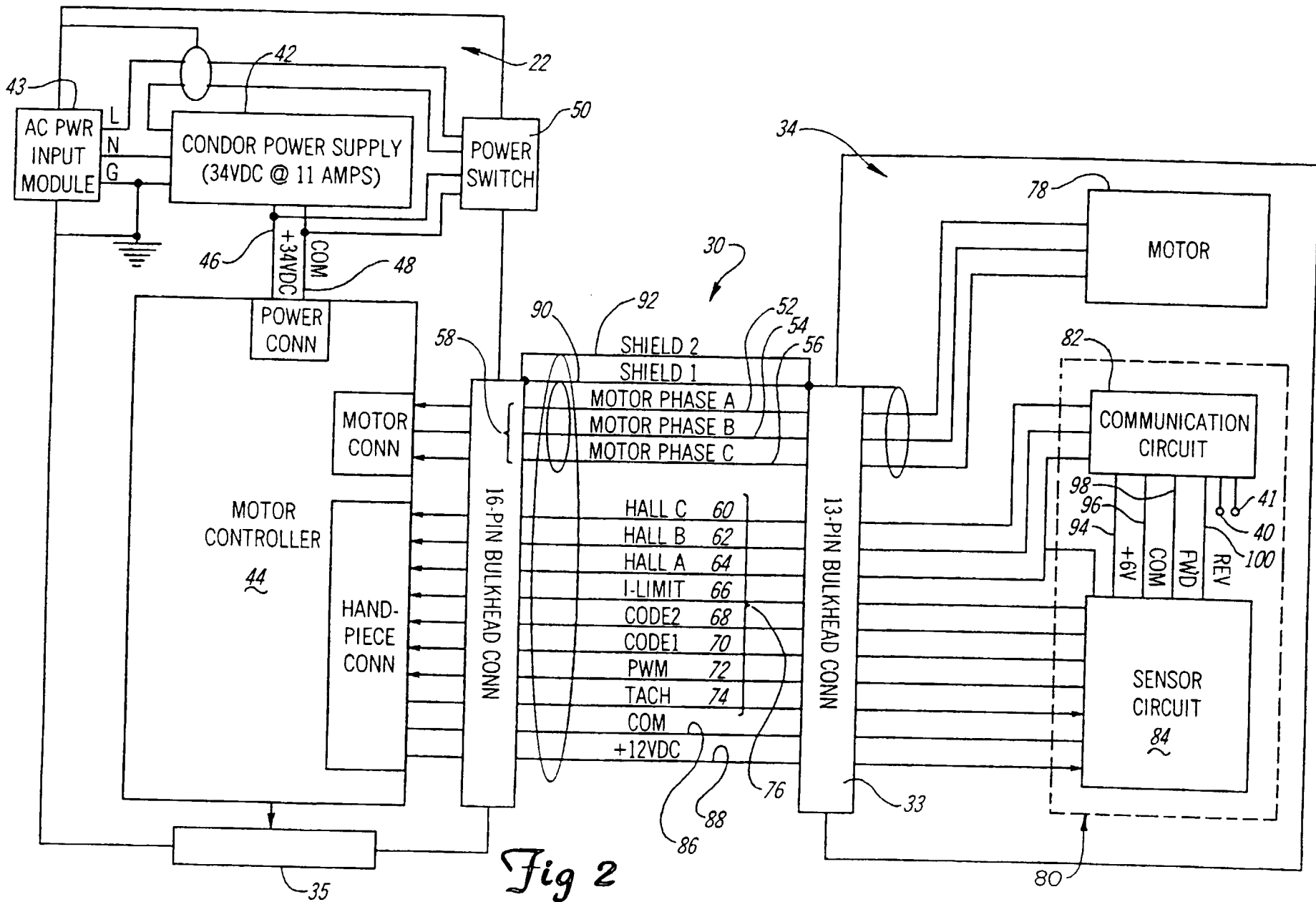

Fig 2

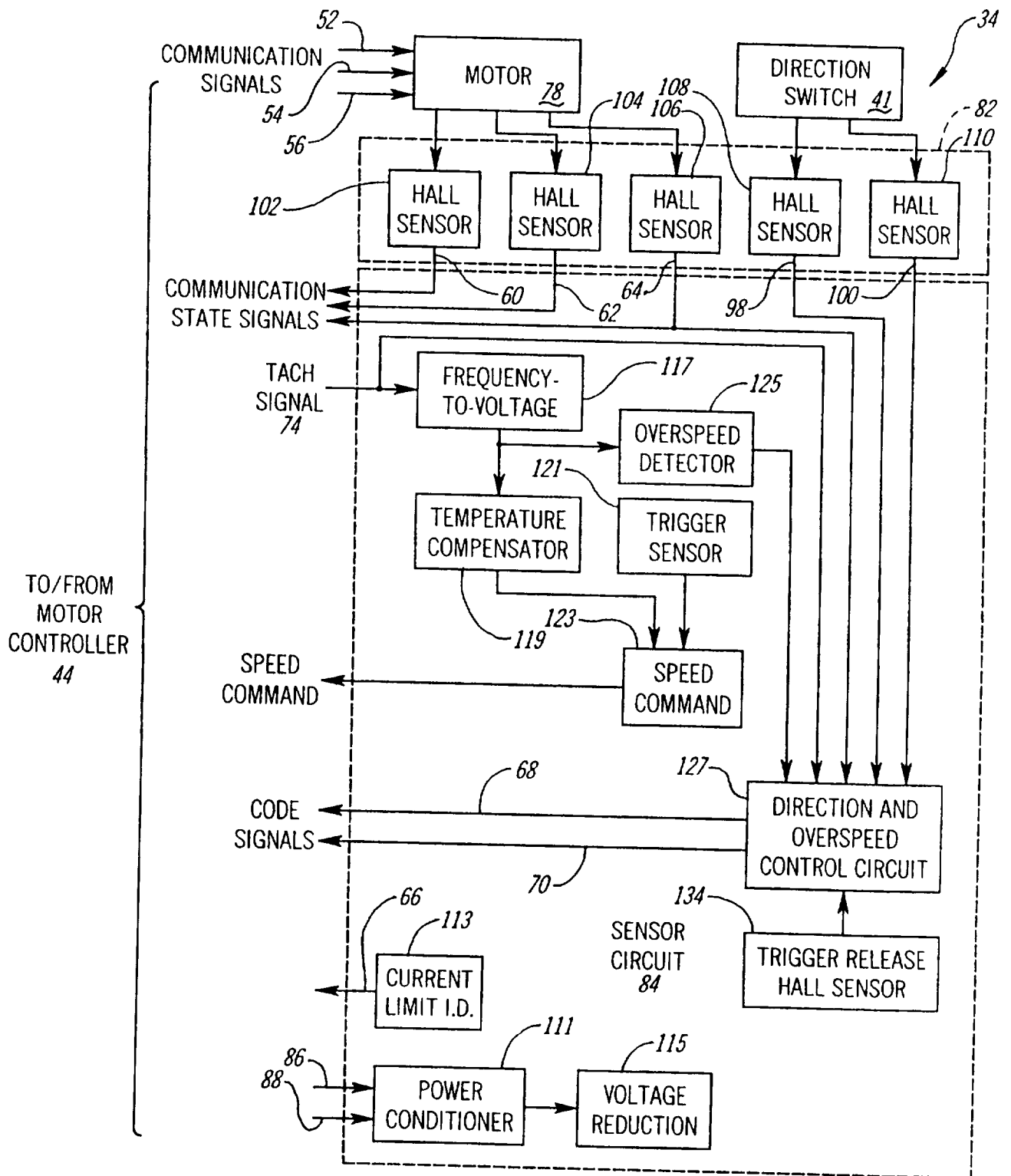

Fig 2A

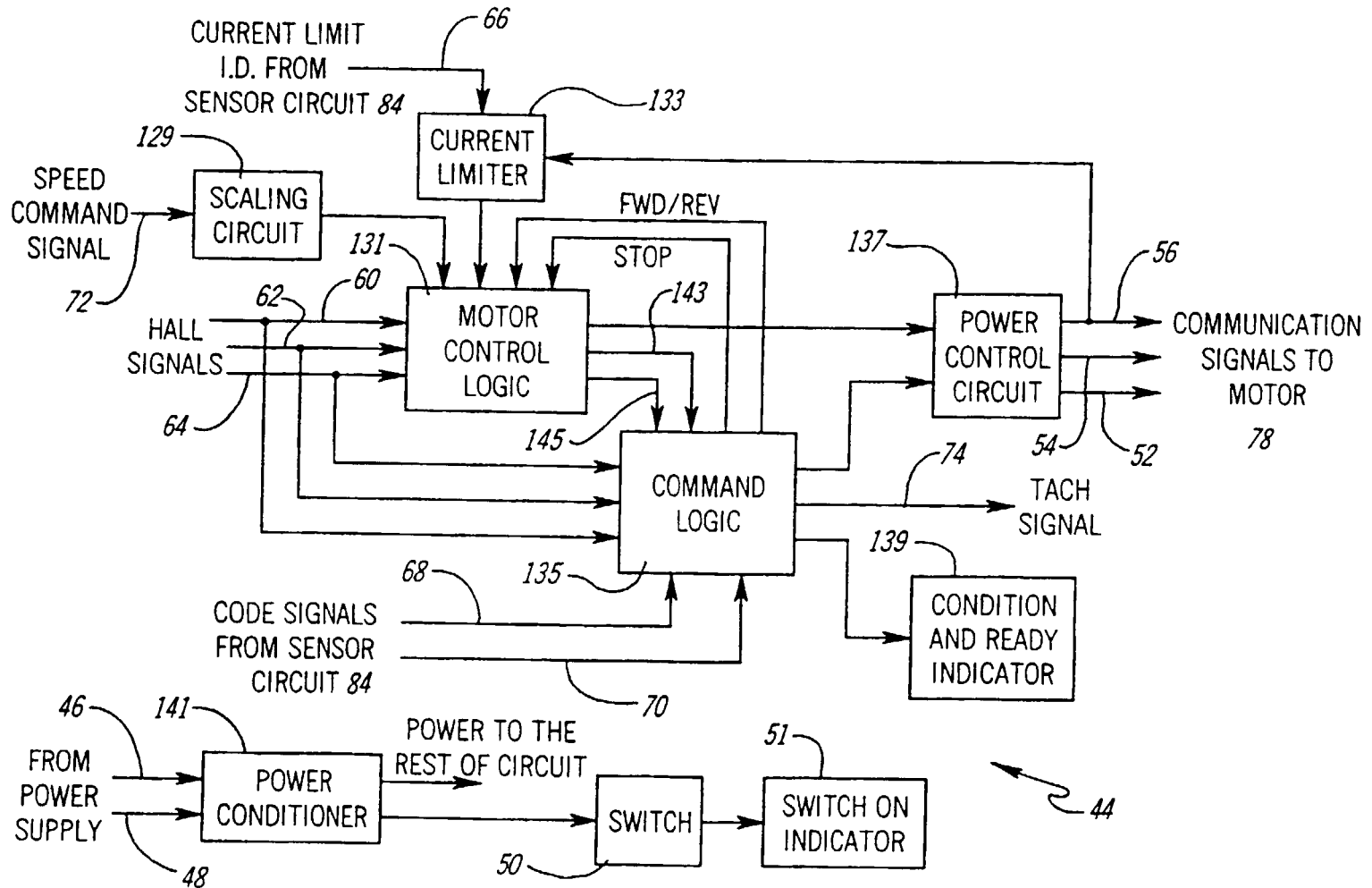

Fig 2B

4/11

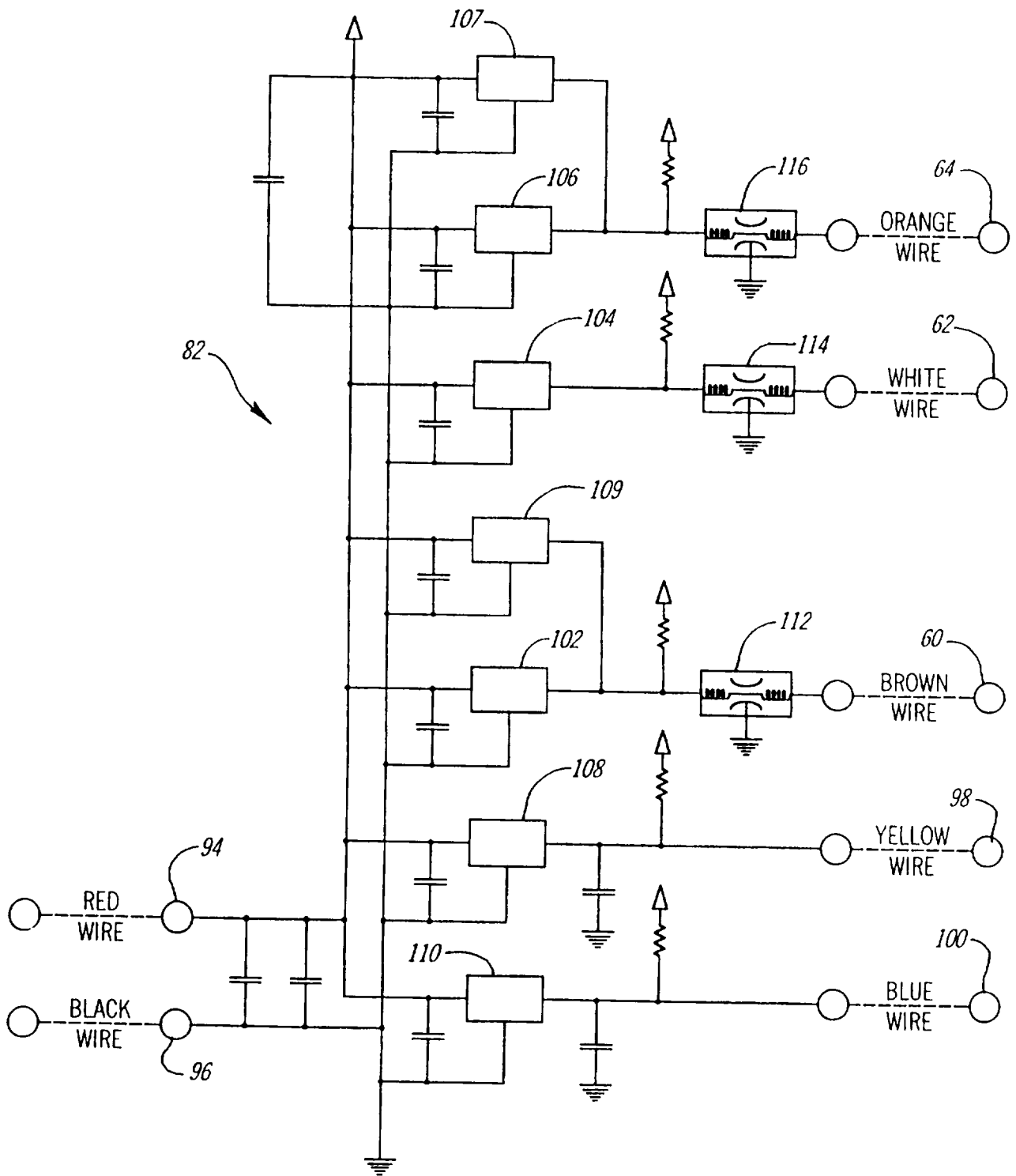
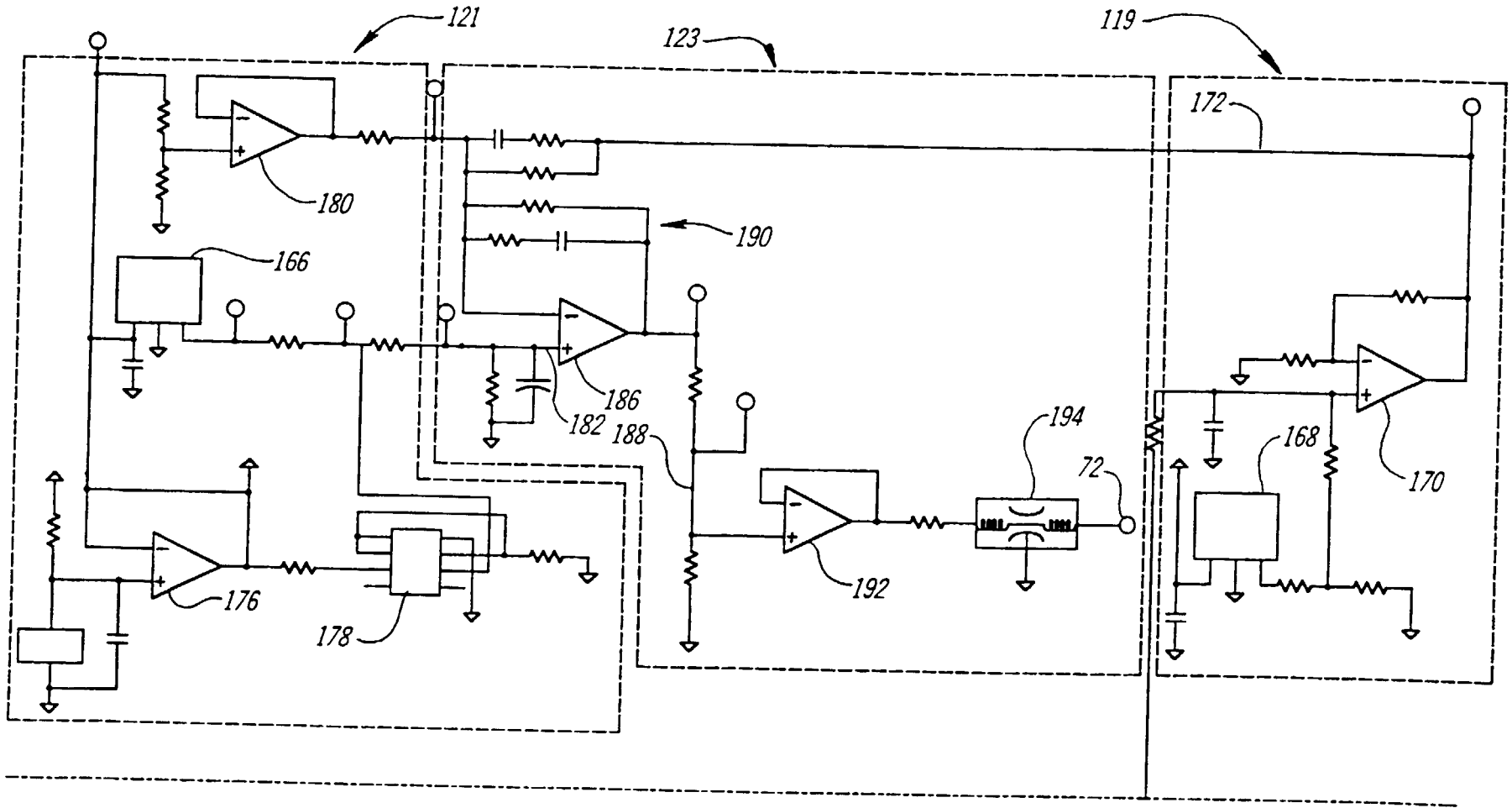

Fig 3

Fig. 4A



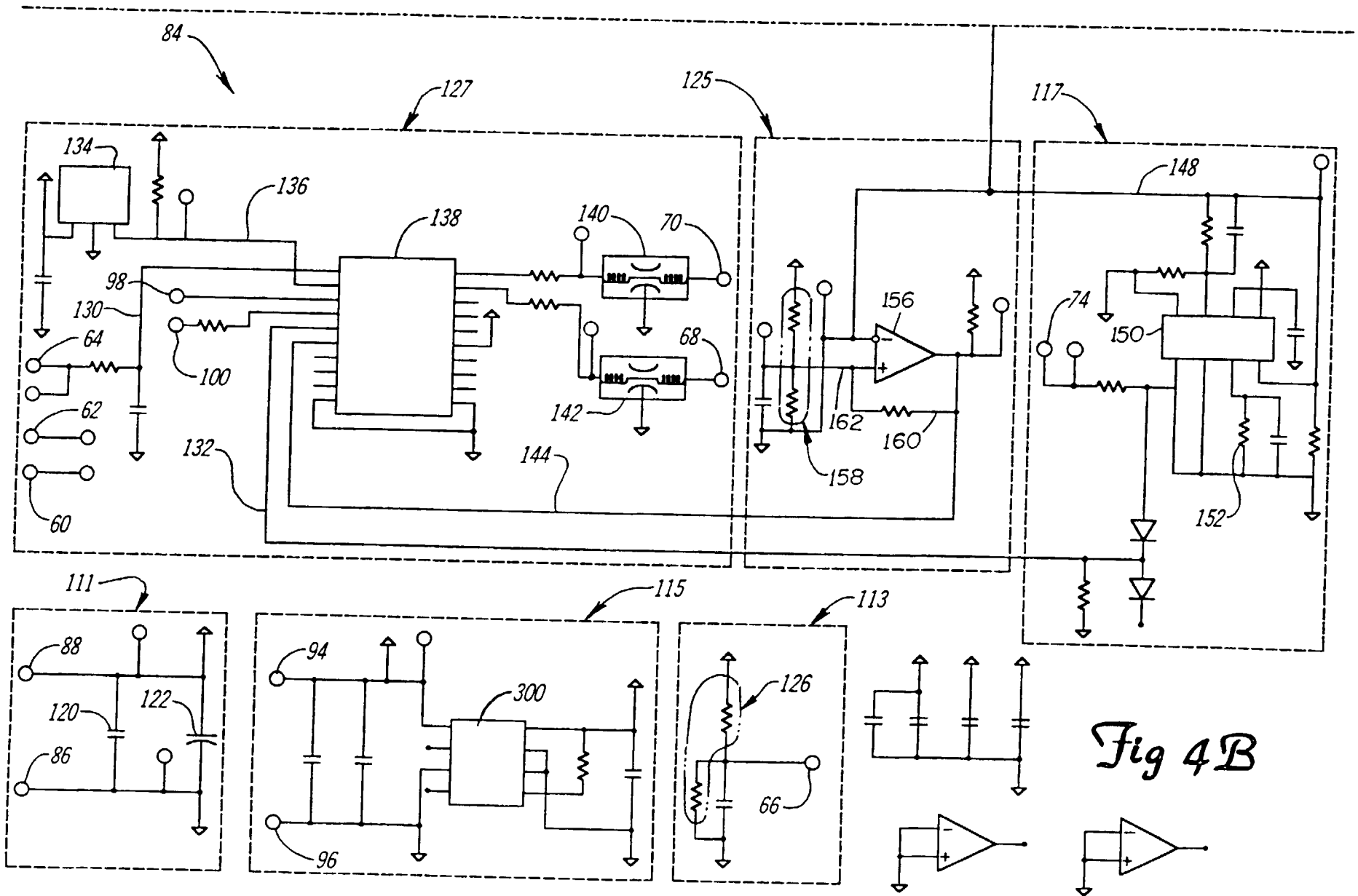

Fig 4B

8/11

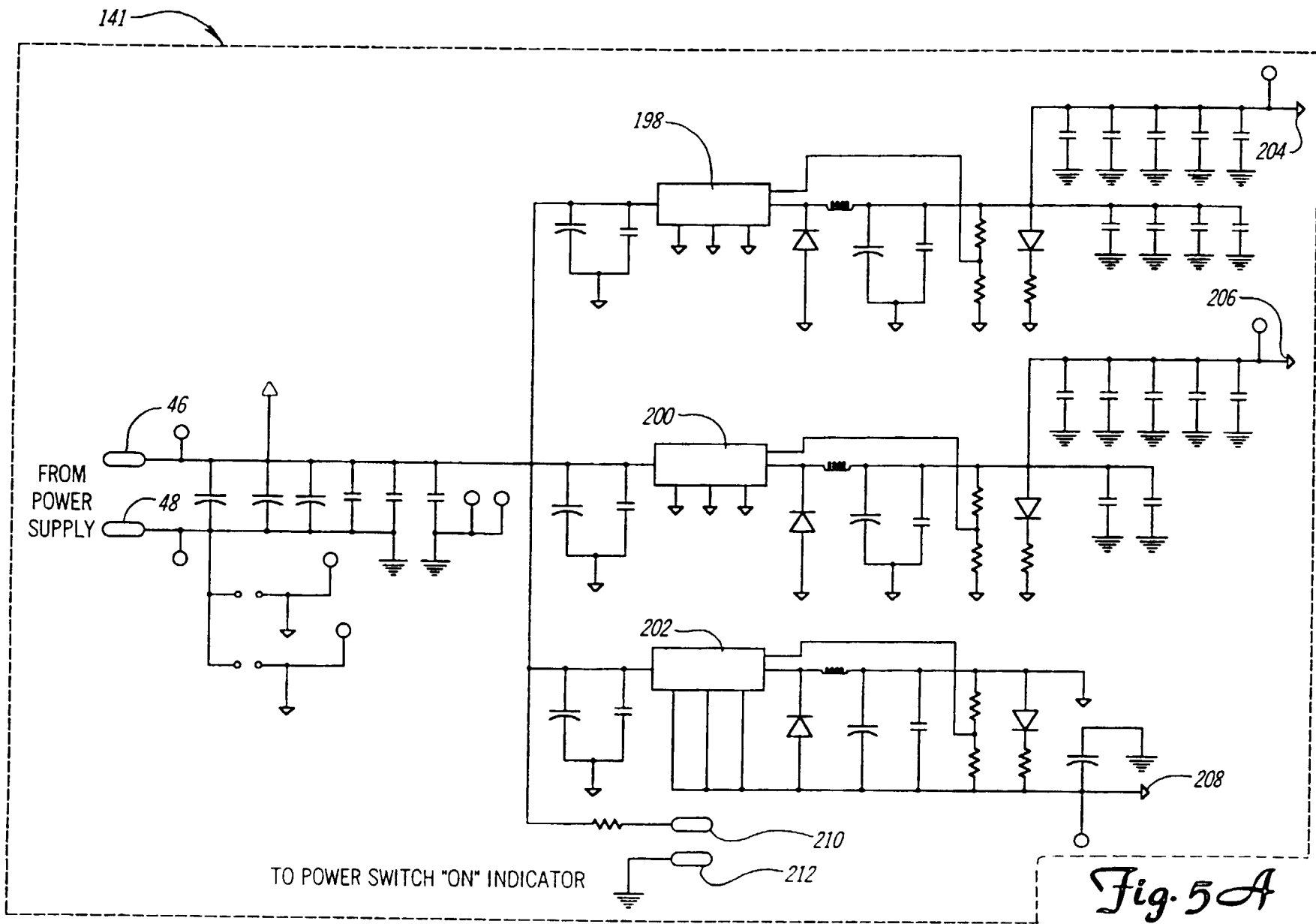

Fig. 5A

9/11

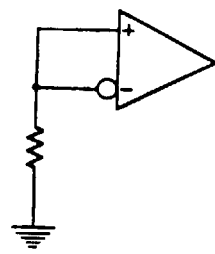
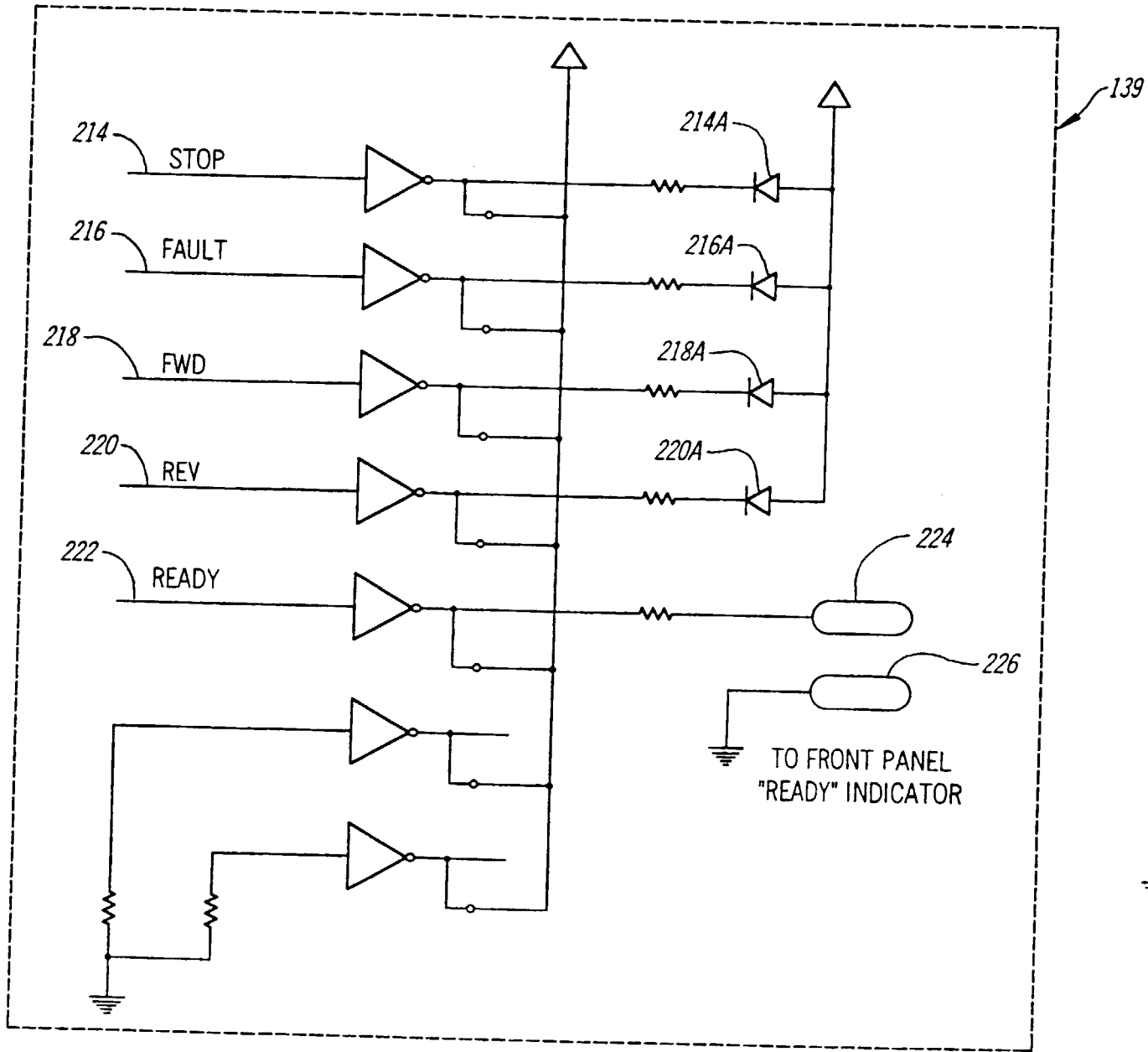

Fig. 5B

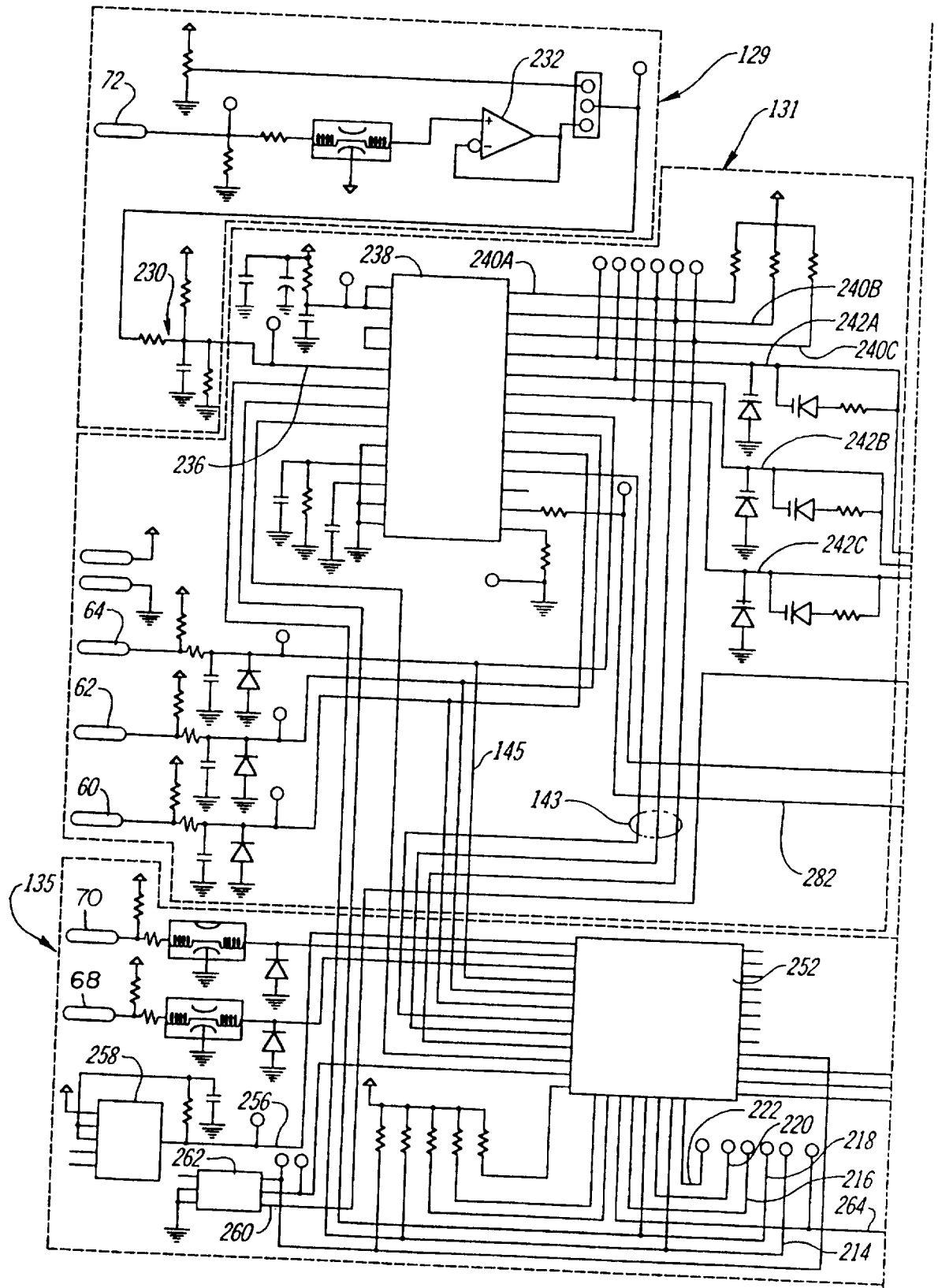

Fig 6A

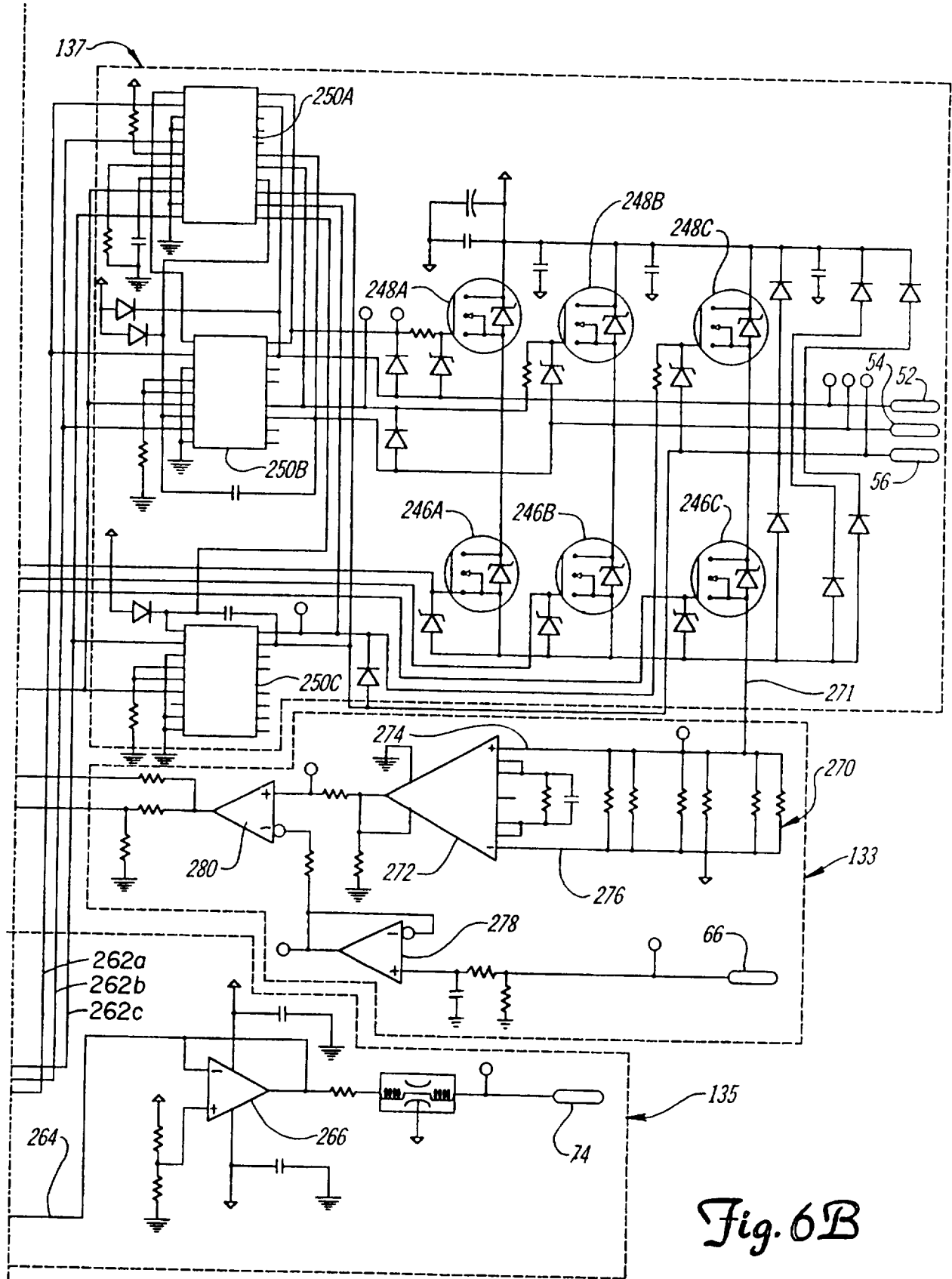

Fig. 6B

# INTERNATIONAL SEARCH REPORT

International Application No

PCT/US 97/08997

A. CLASSIFICATION OF SUBJECT MATTER  
IPC 6 A61B17/58

According to International Patent Classification (IPC) or to both national classification and IPC

**B. FIELDS SEARCHED**

Minimum documentation searched (classification system followed by classification symbols)  
IPC 6 A61B

Documentation searched other than minimum documentation to the extent that such documents are included in the fields searched

Electronic data base consulted during the international search (name of data base and, where practical, search terms used)

**C. DOCUMENTS CONSIDERED TO BE RELEVANT**

Category °	Citation of document, with indication, where appropriate, of the relevant passages	Relevant to claim No.
X	US 4 768 496 A (KREIZMAN ALEXANDER ET AL) 6 September 1988 see the whole document	1-21
A	---	
A	US 5 217 478 A (REXROTH FRED) 8 June 1993 see the whole document	1-21
A	---	
A	WO 94 14129 A (HEMOSTATIX CORP ; SHAW ROBERT F (US)) 23 June 1994 see the whole document	1-21
A	---	
A	WO 96 26696 A (PHOTOGENESIS INC) 6 September 1996 see the whole document	1, 19, 20
	-----	

Further documents are listed in the continuation of box C.

Patent family members are listed in annex.

° Special categories of cited documents :

- \*A\* document defining the general state of the art which is not considered to be of particular relevance
- \*E\* earlier document but published on or after the international filing date
- \*L\* document which may throw doubts on priority claim(s) or which is cited to establish the publication date of another citation or other special reason (as specified)
- \*O\* document referring to an oral disclosure, use, exhibition or other means
- \*P\* document published prior to the international filing date but later than the priority date claimed

- \*T\* later document published after the international filing date or priority date and not in conflict with the application but cited to understand the principle or theory underlying the invention
- \*X\* document of particular relevance; the claimed invention cannot be considered novel or cannot be considered to involve an inventive step when the document is taken alone
- \*Y\* document of particular relevance; the claimed invention cannot be considered to involve an inventive step when the document is combined with one or more other such documents, such combination being obvious to a person skilled in the art.
- \*Z\* document member of the same patent family

Date of the actual completion of the international search

7 October 1997

Date of mailing of the international search report

21.10.97

Name and mailing address of the ISA

European Patent Office, P.B. 5818 Patentlaan 2  
NL - 2280 HV Rijswijk  
Tel. (+31-70) 340-2040, Tx. 31 651 epo nl,  
Fax: (+31-70) 340-3016

Authorized officer

Verelst, P

# INTERNATIONAL SEARCH REPORT

Information on patent family members

International Application No

PCT/US 97/08997

Patent document cited in search report	Publication date	Patent family member(s)	Publication date
US 4768496 A	06-09-88	NONE	
US 5217478 A	08-06-93	US 5632759 A	27-05-97
		US 5269794 A	14-12-93
WO 9414129 A	23-06-94	US 5400267 A	21-03-95
		AU 5870394 A	04-07-94
WO 9626696 A	06-09-96	AU 5415996 A	18-09-96
		CA 2189039 A	06-09-96
		EP 0767641 A	16-04-97