

C. S. BUCKLIN.

Apparatus for Filling Cans with Tomatoes, &c.
No. 143,613. Patented Oct. 14, 1873.

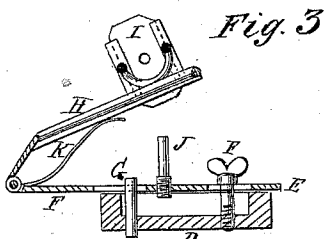
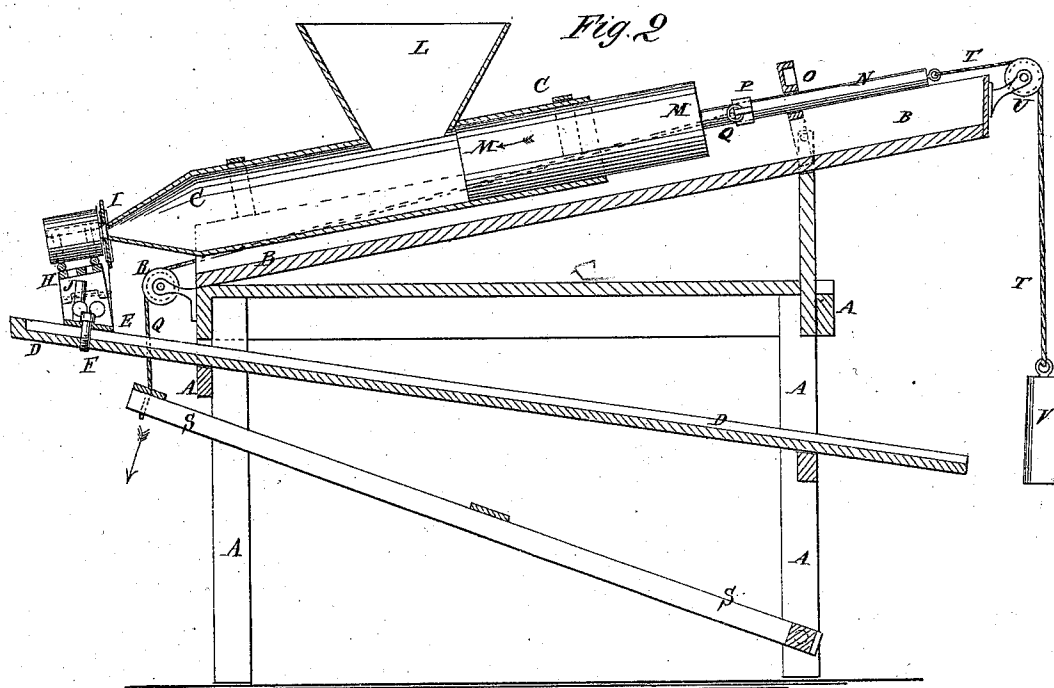
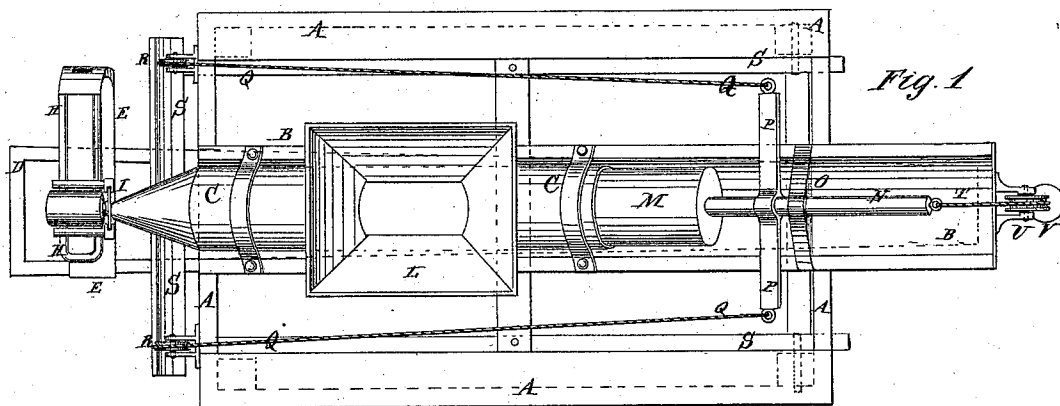

Witnesses:
A. W. Amqvist
Olqvist

Inventor:
C. S. Bucklin
Per *Wm. L.*
Attorneys.

UNITED STATES PATENT OFFICE.

CHARLES S. BUCKLIN, OF RED BANK, NEW JERSEY.

IMPROVEMENT IN APPARATUS FOR FILLING CANS WITH TOMATOES, &c.

Specification forming part of Letters Patent No. **143,613**, dated October 14, 1873; application filed September 27, 1873.

To all whom it may concern:

Be it known that I, CHARLES S. BUCKLIN, of Red Bank, in the county of Monmouth and State of New Jersey, have invented a new and useful Improvement in Can-Filler, of which the following is a specification:

Figure 1 is a top view of my improved machine. Fig. 2 is a vertical longitudinal section of the same. Fig. 3 is a front view of the can-holder, partly in section, to show the construction.

Similar letters of reference indicate corresponding parts.

My invention has for its object to furnish an improved machine for filling cans with tomatoes, or other fruit or substance, which shall be so constructed as to do its work rapidly and effectively, and without injuring or spilling the substance to be canned. The invention consists in the adjustable can-holder formed of the adjustable bar or plate, the hinged frame, the sliding cut-off plate, the stop, and spring, in combination with the tube, and in the arrangement of the tube, the piston, the guide, the cross-bar, cord, and treadle, and the cord and weight, in connection with the frame and troughs, as hereinafter fully described.

A is the frame or table of the machine. B is a trough, which is supported in an inclined position by supports attached to the frame A. In the lower part of the trough B is secured a tube, C, the lower end of which projects below the lower end of the trough B, and is made tapering or funnel-shaped. D is an inclined trough, which rests upon supports attached to the frame A, and which is placed in such a position as to receive any of the substance being canned that may escape from the tube C, or may be spilled while filling the cans, and conduct it into a receptacle placed at the rear of the machine. To the upper and forward end of the trough D is adjustably attached a bar or plate, E, which is secured in place by a set-screw, F, and a guide, G, which pass through slots in the said bar or plate E, and screw into the said trough D. One end of the plate E projects, and to it is hinged the end of a frame, H, upon the upper side of the inner end of which is formed a cradle to receive the can while being filled. I is a plate, which slides up and down in ways attached to the inner

side of the inner end of the frame H. The plate I has a hole formed through it corresponding with the hole through the head of the can and in the end of the tube C. This construction enables the plate I to be so adjusted as to bring the hole in said plate directly opposite the hole in the end of the cans to be filled, so that larger or smaller cans can be filled with the machine, as may be desired. J is a stop-pin screwed into the plate E, for the inner part of the frame H to strike against to limit its downward movement, so that by turning the stop-pin J out or in the downward movement of the frame H may be stopped in such a position as to bring the holes in the plate I and in the can directly opposite the hole in the end of the tube C. K is a spring attached to the bar or plate E, and which should have sufficient strength to raise the frame H, when the filled can is removed, so far as to bring a solid part of the plate I opposite the hole in the end of the tube C, and thus close said hole and prevent the escape of the substance from the tube C. To the upper side of the tube C, near its upper end, is secured the hopper L, through which the substance to be canned is introduced into said tube. M is a piston, which fits into and works in the tube C, and the piston-rod N of which passes through a guide, O, attached to the trough B. To the piston-rod N, between the guide O and upper end of the tube C, is attached a cross-bar, P, to the ends of which are attached the ends of the cords Q. The cords Q pass forward along the opposite sides of the tube C and trough B, pass around guide-pulleys R pivoted to the forward end of the frame A, and are secured to the forward end of the treadle S. The treadle S passes back beneath the frame A, and its rear end is pivoted to the lower rear part of said frame A. To the end of the piston-rod N is attached a cord, T, which passes over a guide-pulley, U, pivoted to the upper end of the trough B. To the lower end of the cord T is attached a weight, V, large enough to draw the piston M out of the tube C when pressure is removed from the treadle. The piston M is kept from being drawn wholly out of the tube C by the cross-bar P striking against the guide O.

Having thus described my invention, I claim

as new and desire to secure by Letters Patent—

1. The adjustable can-holder formed of the adjustable bar or plate E, the hinged frame H, the sliding cut-off plate I, the stop J, and the spring K, in combination with the tube C, substantially as herein shown and described.

2. The arrangement of the tube C, piston M

N, guide O, cross-bar P, cords Q, treadle S, cord T, and weight V, in connection with the frame A and troughs B D, substantially as herein shown and described.

CHARLES S. BUCKLIN.

Witnesses:

JAMES T. GRAHAM,

T. B. MOSHER.