

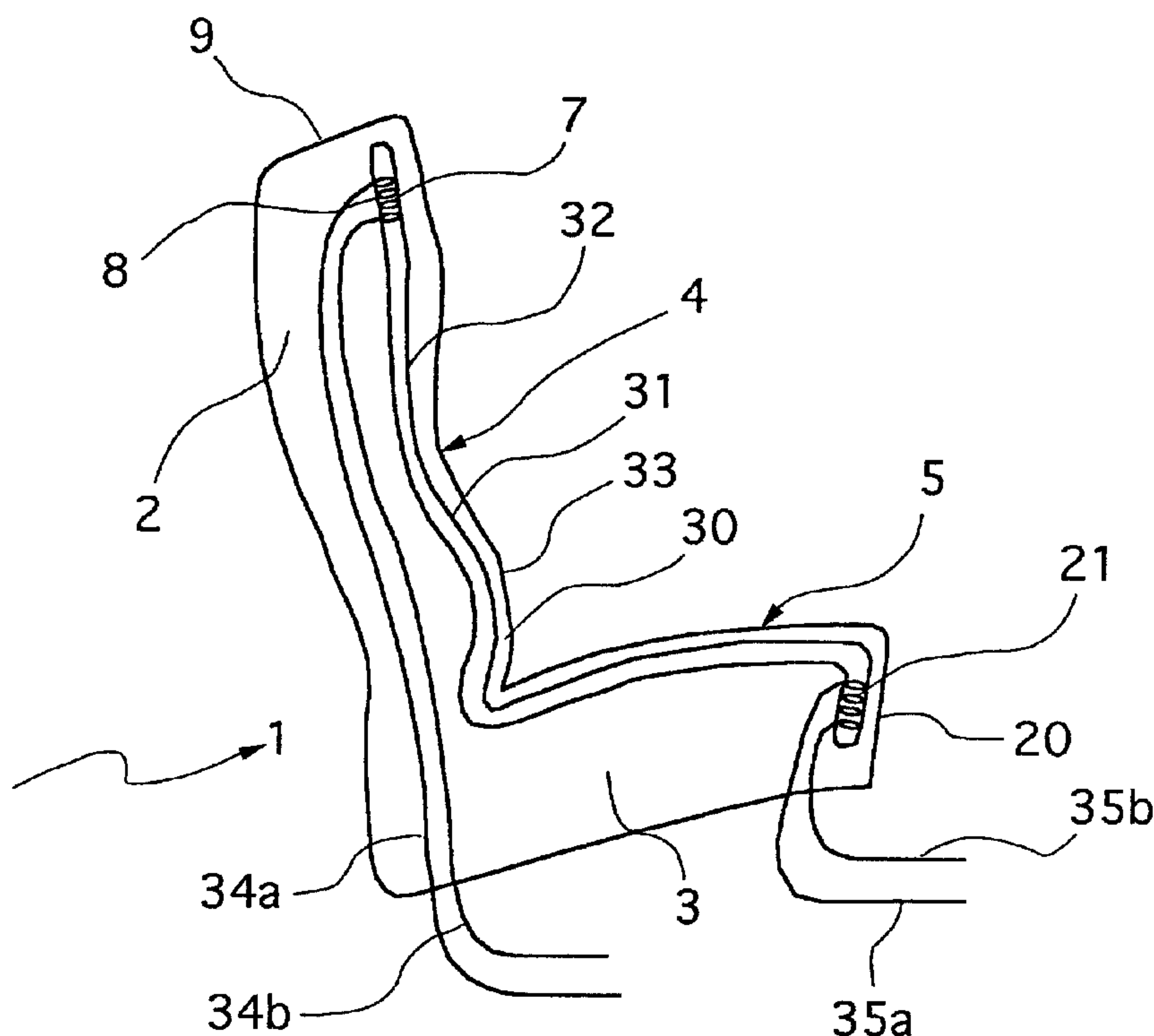

(86) Date de dépôt PCT/PCT Filing Date: 1999/08/31  
 (87) Date publication PCT/PCT Publication Date: 2000/03/09  
 (85) Entrée phase nationale/National Entry: 2001/02/14  
 (86) N° demande PCT/PCT Application No.: FR 1999/002075  
 (87) N° publication PCT/PCT Publication No.: 2000/012948  
 (30) Priorité/Priority: 1998/08/31 (98/11046) FR

(51) Cl.Int.<sup>7</sup>/Int.Cl.<sup>7</sup> F28D 15/02, B60N 2/44, B60H 1/00  
 (71) Demandeur/Applicant:  
ARMINES, FR  
 (72) Inventeur/Inventor:  
CLODIC, DENIS, FR  
 (74) Agent: OYEN WIGGS GREEN & MUTALA

(54) Titre : ECHANGEURS SOUPLE A EFFET CALODUC ASSOCIE A DES CIRCUITS CALOPORTEURS  
 (54) Title: HEAT PIPE EFFECT FLEXIBLE EXCHANGER IN ASSOCIATION WITH HEAT TRANSFER CIRCUITS



(57) Abrégé/Abstract:

The invention concerns a method using a flexible exchanger with heat-pipe effect for controlling the temperature of a plane and/or skew surface walls. The method comprises at least the following steps: applying on said surface (4, 5) a flexible envelope (6) consisting of a layer (30) delimiting a sealed chamber (31) of slight thickness with respect to its width; inserting into said chamber (31) a fluid (32) under vapour pressure, in particular water; carrying out a heat exchange between said fluid and outside air using at least one cool source (7) and/or one hot source (20) in thermal contact with the flexible envelope. Said method can in particular be used to produce a transport vehicle seat.

**PCT**ORGANISATION MONDIALE DE LA PROPRIÉTÉ INTELLECTUELLE  
Bureau international

DEMANDE INTERNATIONALE PUBLIÉE EN VERTU DU TRAITE DE COOPERATION EN MATIÈRE DE BREVETS (PCT)

(51) Classification internationale des brevets <sup>7</sup> : <b>F28D 15/02, B60N 2/44, B60H 1/00</b>	<b>A1</b>	(11) Numéro de publication internationale: <b>WO 00/12948</b>
		(43) Date de publication internationale: 9 mars 2000 (09.03.00)

(21) Numéro de la demande internationale: PCT/FR99/02075

(22) Date de dépôt international: 31 août 1999 (31.08.99)

(30) Données relatives à la priorité:  
98/11046 31 août 1998 (31.08.98) FR(71) Déposant (pour tous les Etats désignés sauf US): ARMINES  
[FR/FR]; 60, boulevard Saint Michel, F-75272 Paris Cedex  
06 (FR).

(72) Inventeur; et

(75) Inventeur/Déposant (US seulement): CLODIC, Denis  
[FR/FR]; 44, rue Emile-Lepeu, F-75011 Paris (FR).(74) Mandataire: VIDON, Patrice; Cabinet Patrice Vidon, Im-  
meuble Germanium, 80, avenue des Buttes de Coësmes,  
F-35700 Rennes (FR).(81) Etats désignés: CA, US, brevet européen (AT, BE, CH, CY,  
DE, DK, ES, FI, FR, GB, GR, IE, IT, LU, MC, NL, PT,  
SE).

Publiée

Avec rapport de recherche internationale.

(54) Title: FLEXIBLE EXCHANGER WITH HEAT-PIPE EFFECT ASSOCIATED WITH HEAT-EXCHANGING CIRCUITS

(54) Titre: ECHANGEURS SOUPLE A EFFET CALODUC ASSOCIE A DES CIRCUITS CALOPORTEURS

## (57) Abstract

The invention concerns a method using a flexible exchanger with heat-pipe effect for controlling the temperature of a plane and/or skew surface walls. The method comprises at least the following steps: applying on said surface (4, 5) a flexible envelope (6) consisting of a layer (30) delimiting a sealed chamber (31) of slight thickness with respect to its width; inserting into said chamber (31) a fluid (32) under vapour pressure, in particular water; carrying out a heat exchange between said fluid and outside air using at least one cool source (7) and/or one hot source (20) in thermal contact with the flexible envelope. Said method can in particular be used to produce a transport vehicle seat.

## (57) Abrégé

La présente invention concerne un procédé mettant en oeuvre un échangeur souple à effet caloduc pour contrôler la température des parois d'une surface (4, 5) plane et/ou gauche. Le procédé comprend l'une au moins des étapes suivantes: d'appliquer sur ladite surface (4, 5) une enveloppe souple (6) composée d'un feuillet (30) délimitant une chambre étanche (31) de faible épaisseur par rapport à son étendue, d'introduire dans ladite chambre (31) un fluide (32) sous sa tension de vapeur, notamment de l'eau, de procéder à un échange de chaleur entre ledit fluide et l'extérieur au moyen d'au moins une source froide (7) et/ou d'une source chaude (20) en contact thermique avec l'enveloppe souple. Le procédé selon la présente invention peut notamment être mis en oeuvre pour réaliser un siège de véhicule de transport.

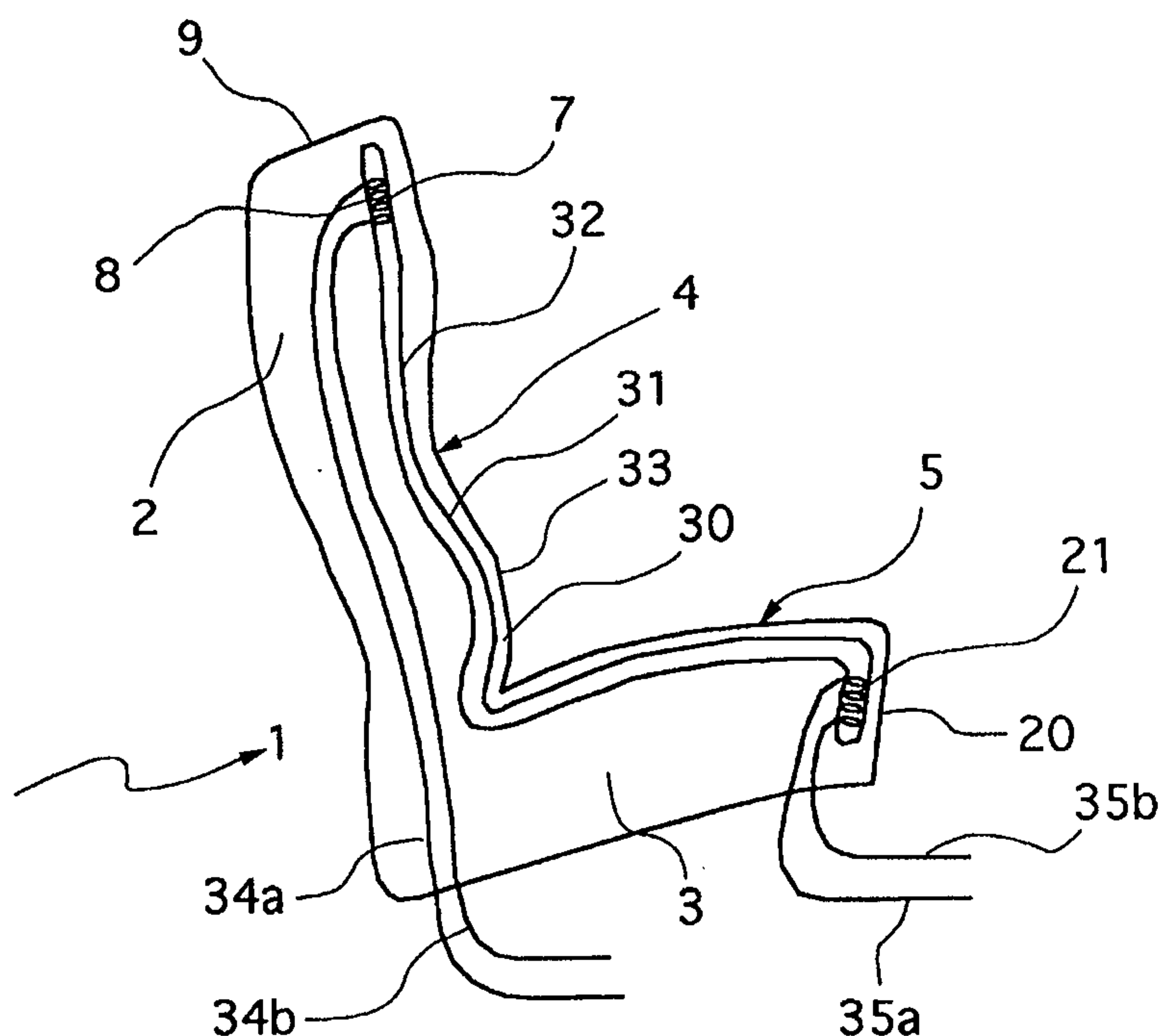

HEAT PIPE EFFECT FLEXIBLE EXCHANGER IN ASSOCIATION WITH  
HEAT TRANSFER CIRCUITS

The present invention concerns a heat pipe effect flexible exchanger in association with heat transfer circuits. It concerns more particularly a process implementing such flexible exchangers in order to control  
5 the temperature of the walls of a plane and/or distorted surface.

The problem raised is that of controlling the temperature of the walls of an enclosure or of an element, particularly a seat located within an automobile vehicle,  
10 so as to ensure the comfort of the users. The thermal comfort of the passengers in transport means must incorporate not only air flow conditions, but also thermal transfers with the seats. Two main situations exist:

- thermal discomfort from the initial temperature of the  
15 seat being too high at the time the passenger goes to seat him/herself or,
- on the contrary, the seat temperature being too cold relative to the thermal optimum.

On the other hand, it is desirable to supply or to  
20 extract heat according to the general thermal conditions in

the passenger compartment. The question therefore is one of exercising effective control over body temperatures on contact with the seat.

A known technique is to position, on the vertical and horizontal parts of a seat, cushions pierced by a large number of apertures on their outward facing faces. Conditioned air is injected into the cushions and escapes through said apertures. Such a device is described in US patent 5,715,695 filed on the 27<sup>th</sup> August 1996 and granted on the 10<sup>th</sup> February 1998. The effect of this device is to make it possible to control the temperature of the parts of the seat on contact with the user. However, it has the drawback of spreading within the passenger compartment a flow of air having circulated nearest to the bodies of the passengers. The result is environmental pollution (odours, moisture content, etc. which may be unpleasant for all the people present in the passenger compartment.

US patent 3,738,702 (James W. JACOBS) describes an automobile vehicle seat comprising a closed heat transfer circuit. The passenger sits down on the seat into which is inserted a cooling cushion passed through by a volatile fluid. To the lower part of this cushion is fitted an evaporator. A pipe connects the upper part of the cushion to a condenser located in the vehicle at the back of the seat. The condensed fluid returns to the evaporator via a circuit located at the back of the seat. The heat energy coming from the passenger is therefore dissipated in the vehicle. Because of this, there is a loss of comfort quality in the passenger compartment. The object of the present invention is to solve the problem raised without having this drawback.

The process according to the invention for controlling the temperature of the walls of a plane and/or distorted

surface located within an enclosure, particularly within the passenger compartment of a vehicle, includes one at least of the following stages.

To the surface whose temperature is to be controlled is applied a flexible jacket conforming in shape to the shape of said surface. Preferably this jacket is made up of a panel delimiting a sealed chamber, forming a heat pipe, of no great thickness relative to its extent.

Into said chamber is introduced a fluid under its vapour pressure at a pre-determined temperature. To advantage water may be used.

There is then a heat exchange between the fluid contained in the flexible jacket and the outside by means of at least one cold source and/or one heat source, forming a heat exchanger, in thermal contact with the flexible jacket. This thermal exchange is effected in at least one pre-determined zone of said surface.

Thus:

- in the event of the thermal exchange occurring on contact with a heat source, the fluid under vapour pressure is vaporised instantaneously on contact with the heat source and extracts heat from said pre-determined zone of the surface to be cooled,

- in the event of the thermal exchange occurring on contact with a cold source, the vaporised fluid condenses instantaneously on contact with the cold source and brings heat to said pre-determined zone of the surface to be heated.

The use of the heat pipe effect makes it possible, in a way known per se, to extract from or bring calories to the exact point on the surface where the temperature is to be controlled. However, thanks to the heat exchanger in relation with the outside of the enclosure, the general

thermal conditions of the passenger compartment are not affected.

Preferably, the cold source or sources are placed at the upper points of the flexible jacket. The result is that  
5 the condensed fluid flows by gravity to the low parts of the flexible jacket. Preferably also, the heat source or sources are placed in the low points of the flexible jacket.

The process according to the invention may be applied  
10 to the thermal pre-conditioning or to the thermal control of the walls of a passenger compartment and/or of a seat, particularly surfaces of a vehicle seat on which the passenger is seated or against which his/her back is leaning.

15 To advantage, in summer operation mode,

- the cold source comprises a heat exchanger in relation with the outside of the passenger compartment and placed at the head of the seat and

20 - the heat source is constituted by all or part of the seat surface on contact with the user.

Likewise, in winter operating mode,

- the heat source comprises a heat exchanger in relation with the outside of the passenger compartment and placed at the lower part of the seat and

25 - the cold source is constituted by all or part of the seat surface on contact with the user.

The present invention also concerns a seat, particularly a transport vehicle seat, made by implementing the processes and the means described above and those which  
30 will be described more exactly with reference to the figures.

The process according to the invention may be applied to the thermal pre-conditioning or to the thermal control

of all or part of the walls of an enclosure, particularly those of a vehicle.

Other characteristics and advantages of the invention will emerge from reading the description of embodiment variants of the invention, given as an illustrative and non restrictive example, and of:

- figure 1 which shows a perspective view of a transport vehicle seat in summer operating mode (cooling mode),

10 - figure 2 which shows a perspective view of a transport vehicle seat in winter operating mode (heating mode),

- figure 3 which shows a cross-section view, along a vertical plane A-A, of the seat shown in figure 1,

15 - figure 4 which shows a perspective view of a vehicle seat and a diagrammatic view of the feed circuits of the exchangers located in the upper part and in the lower part of the seat.

There follows a description of figure 1 which shows a perspective view of a transport vehicle seat in summer operating mode (cooling mode). The seat 1 comprises an approximately vertical part 2 and an approximately horizontal part 3. The passenger (not shown) is seated on the horizontal part 3 and has his/her back leaning against the vertical part 2. His/her body is supported on the pre-determined external distorted surfaces 4 and 5 of the seat 1. To the pre-determined surfaces 4 and 5 whose temperature is to be controlled is applied a flexible jacket 6 conforming in shape to the shape of the surfaces 4 and 5. This jacket 6 is made up of a panel 30 with a double wall (see figure 3) made of a flexible material, for example, of a synthetic plastic material. This panel 30 delimits a sealed chamber 31 of no great thickness relative to its

20  
25  
30

extent. The chamber 31 contains a fluid under its vapour pressure at a pre-determined temperature. To advantage water may be used. There is then an exchange of heat between the fluid 32 contained in the flexible jacket 6, 31 and the outside by means of a cold source and of a heat source in thermal contact with the flexible jacket.

In summer (or cooling) operating mode, that shown in figure 1,

- the cold source 7 comprises a heat exchanger 8 positioned at the head 9 of the seat 1 and

- the heat source is constituted by the surfaces 4 and 5 of the seat on contact with the user.

Thermal exchange is effected on contact with the heat source: the surfaces 4 and 5 of the seat on contact with the user and the surfaces 4 and 5 receiving in the absence of the passenger a solar flux. The fluid under vapour pressure is vaporised instantaneously on contact with the heat source and extracts heat from said pre-determined zone of the surface to be cooled. It condenses in the upper part of the seat where the cold source 7 constituted by the exchanger 8 is located. This exchanger 8 is made of a flexible plastic material. It is in close contact with the jacket 6. The exchanger is fed by a cooling water system the temperature of which is substantially lower than the wall temperature of the flexible jacket 6. Typically the cooling water temperature is lower than 2 to 10°C. This water system may be cooled by a conventional refrigerating unit or by any other type of refrigerating system. The heat is extracted and, given the great efficiency of the transfers between the flexible jacket 6 and the exchanger 8, the surface temperature of the seat will be greater, typically of the order of 2°C, than the cooling water inlet temperature. In the same way, if a passenger sits down on

the seat and their external clothing temperature is of the order of 27 to 30°C, according to the cooling requirements, an adjustable quantity of heat will be extracted under a very low temperature difference.

5 The condensed fluid flows by gravity to the low parts of the jacket, on the surfaces 4 and 5 of the seat to be cooled.

The thermal equations in cooling operating mode are as follows:

10  $T_1 < T_2$

$M_{lt} = (T_1 + T_2) / 2$

$M_{lt} < T_{ai}$

Losses + Sum of the  $Q_i = Q$  extracted

$T_1$  denoting the exchanger 8 inlet temperature.

15  $T_2$  denoting the exchanger 8 outlet temperature.

$Q_i$  denoting the heat load received from the outside (from the passenger) by the zone  $i$  of the surfaces 4 and 5.

$T_{ai}$  denoting the temperatures of the zones  $i$ .

20 There will now be a description of figure 2 which shows a perspective view of a transport vehicle seat in winter operating mode (heating mode). Most of the elements described may be recognised with reference to figures 1 and 3. They bear the same references.

In winter operating mode (heating mode),

25 - the heat source 20 comprises a heat exchanger 21 positioned in the lower part 22 of the seat 1 and

- the cold source is constituted by all or part of the surface 4, 5 of the seat on contact with the user.

30 The heat exchanger 21 is fed by water at a higher temperature than the average temperature of the seat. The temperature is such that any point on the flexible jacket is at a temperature lower than the part of the flexible jacket 6 in contact with the exchanger 21.

Thermal exchange is effected on contact with the cold source 4, 5. The fluid 32, vaporised at heat exchanger level 21, condenses instantaneously on contact with the cold source 4, 5 and brings heat to said pre-determined zone of the surface of the seat to be heated. The condensed fluid flows by gravity to the low parts of the jacket, to heat source 20 and heat exchanger 21 level. The heating mode may be used in pre-conditioning the seat or when a passenger is seated.

The thermal equations in heating operating mode are as follows:

$$T3 > T4$$

$$Mht = (T3 + T4) / 2$$

$$Mht < Tbi$$

$$Q = \text{Sum of the } Qi + \text{Losses}$$

T3 denoting the exchanger 21 inlet temperature.

T4 denoting the exchanger 21 outlet temperature.

Qi denoting the heat load supplied to the outside (to the passenger) by the zone i of the surfaces 4 and 5.

Tbi denoting the temperatures of the zones i.

It will be noted that in winter operating mode (heating mode), the exchanger 8 located in the upper part 9 of the seat 1 is shut off. Conversely, in summer operating mode (cooling), the exchanger 21 located in the lower part 22 of the seat 1 is shut off.

There now follows a description of figure 3 which shows a cross-section view along a vertical plane A-A, of the seat shown in figure 1. In this figure 3 may be recognised the elements described with reference to figures 1 and 2, they bear the same references. Figure 3 shows the position of the upper exchanger 8 and of the lower exchanger 21, located respectively at the head 9 and in the lower part of the seat 20, on thermal contact with the

sealed flexible jacket 6, 31. Figure 3 also shows the position of the flexible jacket 6, 31 containing the coolant 32, under the outer lining 33 of the seat, on thermal contact with the passenger's body. The feed  
5 circuits 34a and 34b connect the upper exchanger 8 to the vehicle air-conditioning system. The feed circuits 35a and 35b connect the lower exchanger 21 to the vehicle heating system.

There now follows a description of figure 4 which  
10 shows a perspective view of the vehicle seat shown in figures 1 to 3 and a diagrammatic view of the feed circuits of the exchangers located in the upper part and in the lower part of the seat. In this figure 4 may be recognised the elements described with reference to figures 1 to 3,  
15 they bear the same references. Figure 4 shows the circuits 34a and 34b connecting the thermal exchanger 8 to the air-conditioning system. In practice, they are connected to a heat exchanger 40. The heat exchanger 40 is connected to the vehicle air-conditioning system, by means of the pipes  
20 41a and 41b. A circulator 42 makes it possible to control the operation of the upper exchanger 8. A solenoid valve 43 makes it possible to control the operation of the lower exchanger 21; a circulator is not required since the coolant systems of the engines are fitted with a pump.

25 Even though re-filling the evaporator part of the heat pipe effect flexible jacket may be carried out by capillary action, refilling with liquid is always more efficient when the surface condensers are in the upper part. However, in certain embodiment variants re-filling by capillary action  
30 may be preferred. In this case, the condensation pole will no longer necessarily be positioned in the upper part of the flexible jacket.

CLAIMS

1. A process for controlling the temperature of the walls of a plane and/or distorted surface (4, 5), located within an enclosure, particularly within a vehicle passenger compartment,

5 said process being characterised in that it includes the following stages:

- applying to said surface a flexible jacket (6) conforming in shape to the shape of said surface, said jacket being made up of a panel (30) delimiting a sealed  
10 chamber (31), forming a heat pipe, of no great thickness relative to its extent,

- introducing into said chamber a fluid (32) under its vapour pressure at a pre-determined temperature, particularly water,

15 - producing a heat exchange between said fluid and the outside by means of at least one cold source (7) and/or one heat source (20), forming a heat exchanger, in thermal contact with the flexible jacket, said thermal exchange occurring in at least one pre-determined zone of  
20 said surface (4, 5).

2. A process according to claim 1 such that:

- the cold source or sources are positioned at upper points (9) of the flexible jacket (6).

3. A process according to any one of claims 1 or 2  
5 such that:

- the heat source or sources are positioned at low points (22) of the flexible jacket (6).

4. Application of the process according to any one of claims 1 to 3 to the thermal preconditioning or to the  
10 thermal control of the walls of a passenger compartment and/or of a seat (1), particularly a vehicle seat.

5. Application according to claim 4 such that:

- in summer operating mode,

\* the cold source (7) comprises a heat exchanger (8)  
15 in relation with the outside of the passenger compartment and positioned at the head (9) of the seat (1) and

\* the heat source is constituted by all or part of the surface (4, 5) of the seat on contact with the user,

- in winter operating mode,

20 \* the heat source (20) comprises a heat exchanger (21) in relation with the outside of the passenger compartment and positioned in the lower part (22) of the seat (1) and

\* the cold source (7) is constituted by all or part  
25 of the surface (4, 5) of the seat on contact with the user.

6. A seat made in application of any one of claims 4 or 5.

7. Application of the process according to any one  
30 of claims 1 to 3 to the thermal preconditioning or to the

thermal control of all or part of an enclosure, particularly a vehicle.

8. A system for controlling the temperature of the walls of a plane and/or distorted surface (4, 5), located  
5 within an enclosure, particularly within a vehicle passenger compartment,

said system being characterised in that it includes:

- a flexible jacket (6) conforming in shape to the shape of said surface, said jacket being made up of a  
10 panel (30) delimiting a sealed chamber (31), forming a heat pipe, of no great thickness relative to its extent,

- a fluid (32), particularly water, contained in said chamber under its vapour pressure at a pre-determined temperature,

15 - a cold source (7) and/or a heat source (20), in thermal contact with the flexible jacket, in at least one pre-determined zone of said surface (4, 5); said cold source (7) and/or said heat source (20) respectively comprising a heat exchanger with the outside of said  
20 enclosure.

9. A system according to claim 8 such that:

- the cold source or sources are positioned at upper points (9) of the flexible jacket (6).

10. A system according to any one of claims 8 or 9  
25 such that the heat source or sources are positioned at low points (22) of the flexible jacket (6).

11. Use of the system according to any one of claims 8 to 10 for the thermal preconditioning or for the thermal control of the walls of a passenger compartment  
30 and/or of a seat (1), particularly a seat located in the passenger compartment of a vehicle.

12. Use of the system according to claim 11 such that:

- in summer operating mode,

\* the cold source (7) comprises a heat exchanger (8) in relation with the outside of the passenger compartment and positioned at the head (9) of the seat (1) and

\* the heat source is constituted by all or part of the surface (4, 5) of the seat on contact with the user,

- in winter operating mode,

\* the heat source (20) comprises a heat exchanger (21) in relation with the outside of the passenger compartment and positioned in the lower part (22) of the seat (1) and

\* the cold source (7) is constituted by all or part of the surface (4, 5) of the seat on contact with the user.

13. Use of the system according to any one of claims 11 or 12 applied to the manufacture of a seat.

14. Use of the system according to any one of claims 8 to 10 for the thermal preconditioning or for the thermal control of all or part of the walls of an enclosure, particularly a vehicle.

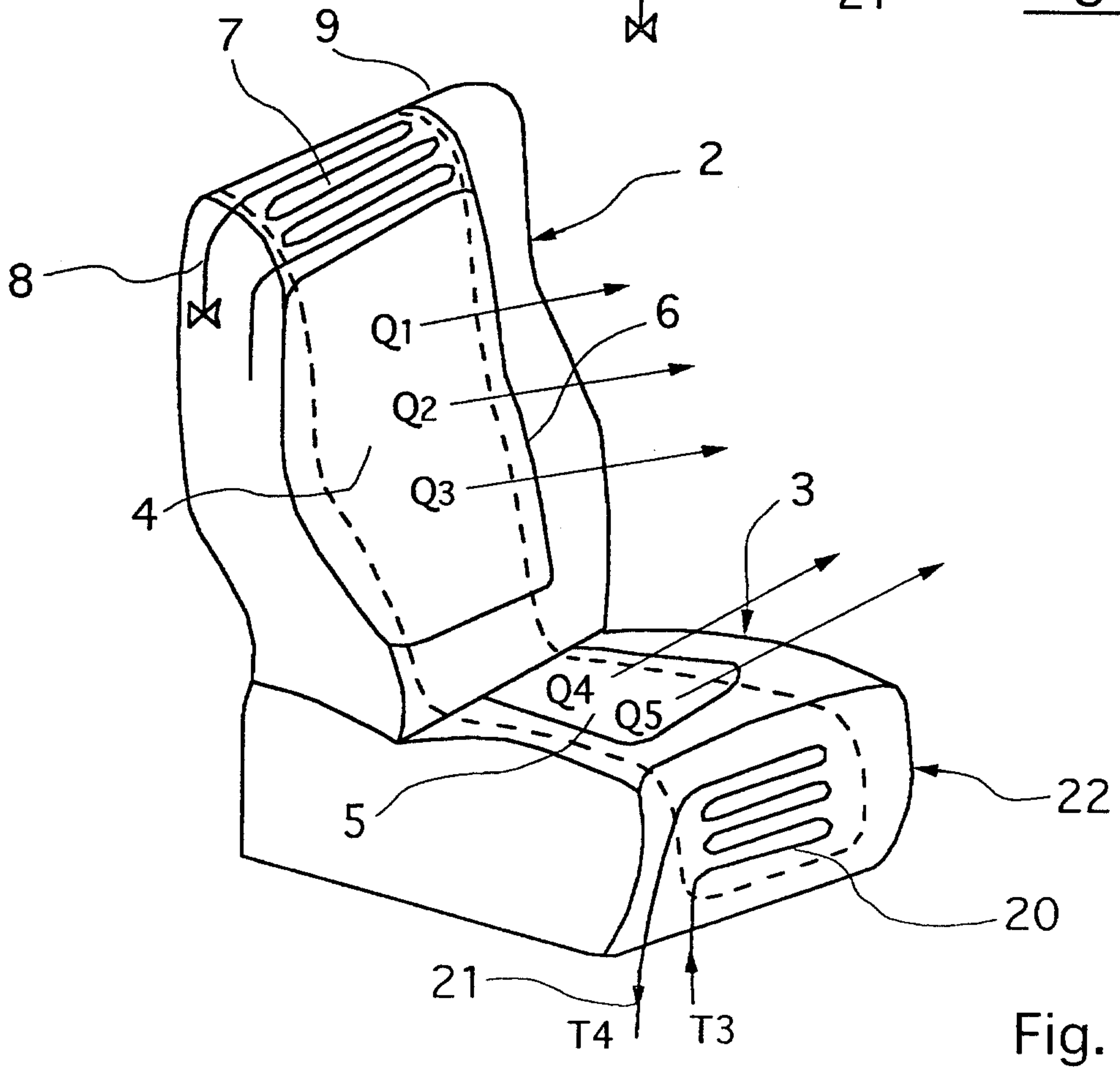
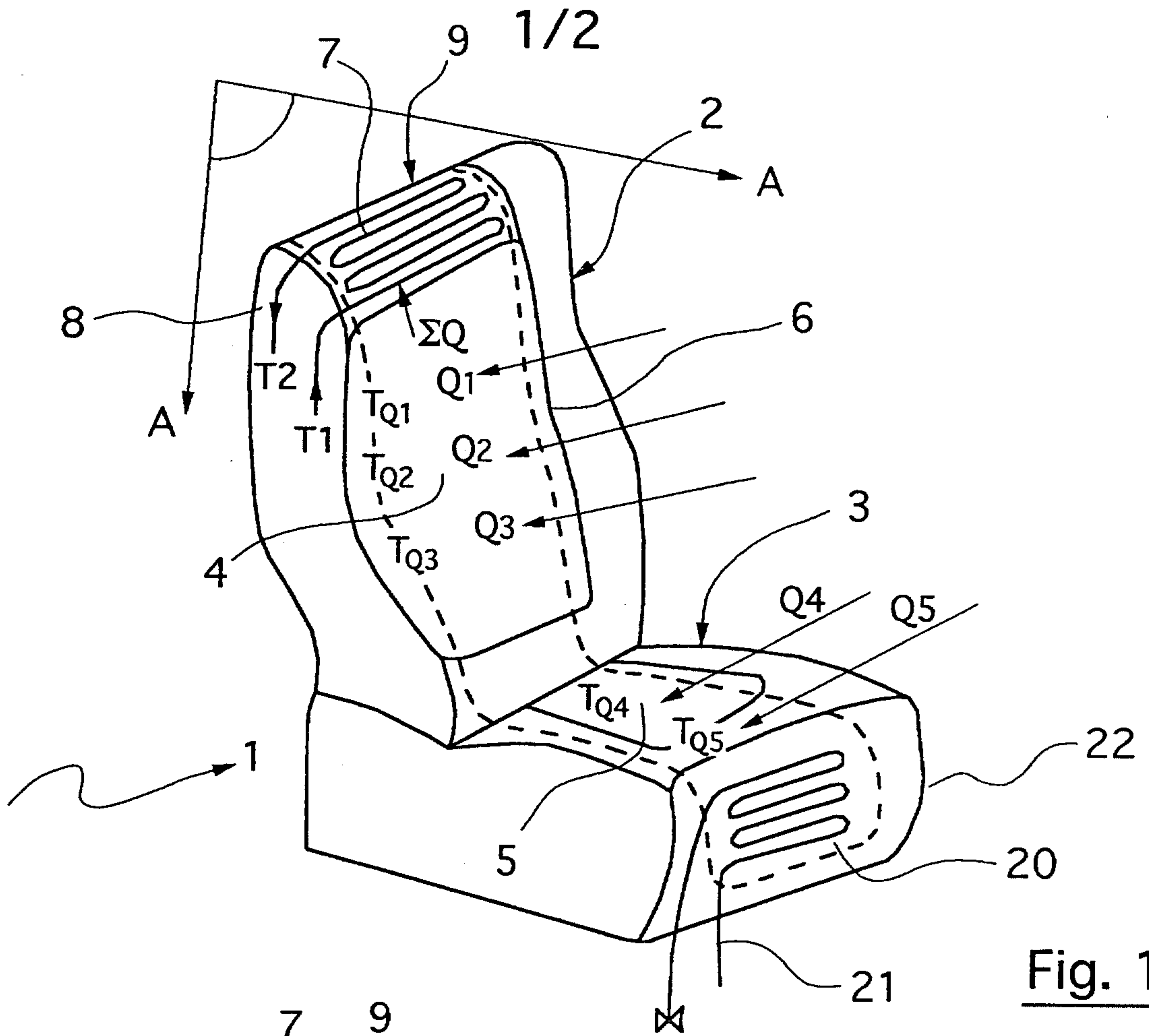

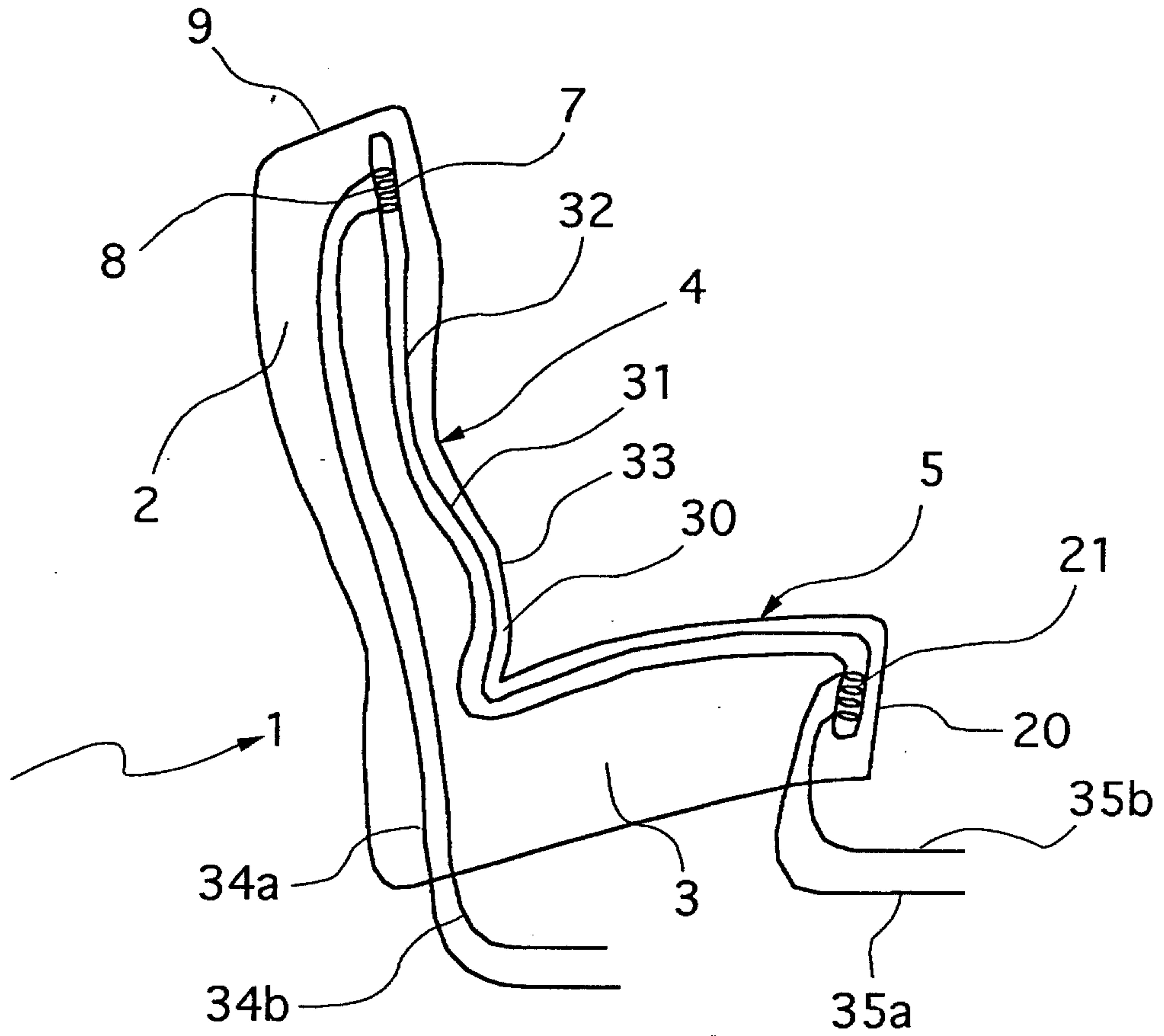

Fig. 3

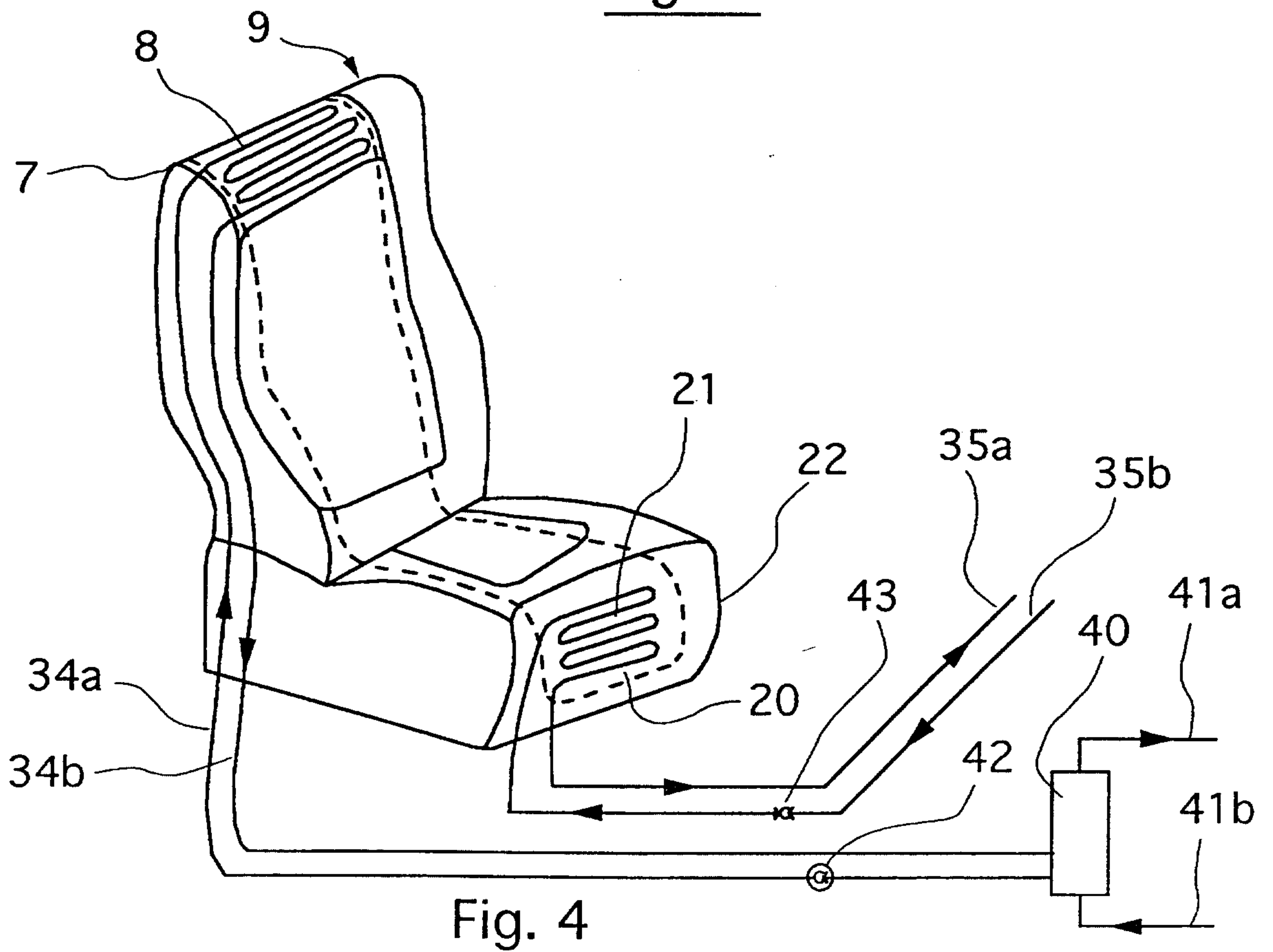

Fig. 4

