

(19) **DANMARK**

(10) **DK/EP 3112030 T3**



(12) **Oversættelse af
europæisk patentskrift**

Patent- og
Varemærkestyrelsen

-
- (51) Int.Cl.: **B 03 C 3/74 (2006.01)**
- (45) Oversættelsen bekendtgjort den: **2021-08-09**
- (80) Dato for Den Europæiske Patentmyndigheds bekendtgørelse om meddelelse af patentet: **2021-05-05**
- (86) Europæisk ansøgning nr.: **16382292.7**
- (86) Europæisk indleveringsdag: **2016-06-23**
- (87) Den europæiske ansøgnings publiceringsdag: **2017-01-04**
- (30) Prioritet: **2015-06-30 ES 201531292 U**
- (84) Designerede stater: **AL AT BE BG CH CY CZ DE DK EE ES FI FR GB GR HR HU IE IS IT LI LT LU LV MC MK MT NL NO PL PT RO RS SE SI SK SM TR**
- (73) Patenthaver: **Universidad de Vigo, Campus Universitario, s/n , As Lagoas - Marcosende, 36310 Vigo Pontevedra, Spanien**
- (72) Opfinder: **MÍGUEZ TABARÉS, Jose Luis, UNIVERSIDAD DE VIGO, Campus Universitario, s/n, As Lagoas - Marcosende, 36310 VIGO (PONTEVEDRA), Spanien**
PORTEIRO FRESCO, Jacobo, UNIVERSIDAD DE VIGO, Campus Universitario, s/n, As Lagoas - Marcosende, 36310 VIGO (PONTEVEDRA), Spanien
PATIÑO VILAS, David, UNIVERSIDAD DE VIGO, Campus Universitario, s/n, As Lagoas - Marcosende, 36310 VIGO (PONTEVEDRA), Spanien
GRANADA ÁLVAREZ, Enrique, UNIVERSIDAD DE VIGO, Campus Universitario, s/n, As Lagoas - Marcosende, 36310 VIGO (PONTEVEDRA), Spanien
- (74) Fuldmægtig i Danmark: **Plougmann Vingtoft A/S, Strandvejen 70, 2900 Hellerup, Danmark**
- (54) Benævnelse: **SELVREGENERERENDE ELEKTROSTATISK UDSKILLER**
- (56) Fremdragne publikationer:
EP-A1- 2 583 755
WO-A1-2005/097332
DE-A1- 10 345 925
DE-U1-202007 004 263
JP-A- 2002 047 914
JP-A- 2004 132 338
US-A- 6 092 387
US-A1- 2005 262 817
US-A1- 2009 074 630

DESCRIPTION

TECHNICAL FIELD

[0001] The present invention is comprised in the field of systems or apparatus for reducing contaminating emissions in combustion systems, and more specifically for reducing emissions of particles in suspension in a gas stream generated, for example, by a biomass boiler or a diesel engine. The invention is particularly comprised in the field of electrostatic precipitators.

PRIOR ART

[0002] Any combustion system is susceptible to generating contaminating emissions. These emissions are gas emissions, but they can also contain solid or liquid particles in suspension as a result of an imperfect combustion or ash present in the fuel exiting the system with the gas stream. Solid (biomass and carbon) combustion systems as well as reciprocating internal combustion (particularly diesel) engines are particularly unique as regards emissions of this type. The reason for their risks resides in the large number of particles given off and their reduced size (smaller than 1 μm) which do not readily settle in the atmosphere and are impossible for the human respiratory system to filter out.

[0003] For the reasons set forth, it is common to introduce filtering elements into these combustion systems to minimize particle emissions. Though less widespread in the field of biomass boilers, particle filters are usually installed in diesel engines to comply with environmental regulations.

[0004] There are several strategies for reducing particle emissions. Among others, settling chambers or cyclones that separate the particles by centrifugal force, filtering systems that retain aerosols by means of a porous (for example fiber) bed, or electrostatic precipitators that electrically charge the particles to then remove them from the gas stream as a result of the strong electric field generated between two electrodes, can be used.

[0005] Each of the mentioned systems has features making them more or less advantageous depending on the type of combustion system. In many cases, one of the biggest problems for the application thereof is the removal of particles deposited throughout the service life of the filter. As an example, a filtering system is used in diesel engines that accumulates unburned particles (of an organic origin) over time, and every so often they use a regeneration cycle. In other words, they send very hot gases to the filter, and as a result of the high temperature reached they burn the deposited particles again, recovering the filtration element's efficiency.

[0006] In other cases, such as in electrostatic precipitators, for example, it is common to introduce a mechanical element on the deposition collector which shakes, scrapes or hits the

collector every so often, causing the particles to become detached, which are then collected in a waste disposal element in the lower area.

[0007] In scientific and patent literature, there are a number of proposals for regenerating or cleaning particle filtering systems which are primarily based on regeneration cycles with hot gases or on applying electric heating techniques.

[0008] The present invention proposes a particle filtering system using electrostatic precipitation which solves the aforementioned problems in the prior art.

[0009] In this point, it is cited the document JP2002047914 that discloses an exhaust emission control device for reducing the discharged amount of exhaust gas of a diesel automobile engine, comprising an electromagnetic coil in the bottom part of a closed collection pipe with adsorption materials, where this electromagnetic coil heats a ceramic plate and has an electrically-driven fan for cooling. However, it can not be disposed vertically in the outer part of an open cylinder and differs from the particle filtering system of the present patent application.

DISCLOSURE OF THE INVENTION

[0010] The present invention relates to a particle filtering system using electrostatic precipitation which is self-cleaning by means of heating the walls by electromagnetic induction. This self-cleaning method allows the continuous operation of the device and the removal of most of the trapped mass, thereby reducing emissions of solid particles in suspension in a gas stream in a continuous manner.

[0011] The present invention proposes a system for filtering solid particles resulting from combustion by means of a self-regenerative electrostatic precipitator. A cylindrical precipitator with a high-voltage electrode in the center of the chimney or gas conduit generates a strong electric field which results in the creation of a corona discharge region. The particles in suspension in the gas stream, most of which are of a carbon origin (unburned), are ionized and deflected towards the deposition electrode by the same electric field that charged them or by another different one (a one- or two-stage precipitator). The deposition electrode of the present invention will be the outer cylindrical body of the conduit (or conduits) in which deposition takes place.

[0012] As material is being deposited on the chimney, and always before the electric field weakens and filtering efficiency becomes impaired, a series of induction coils outside the tube will be electrically activated. These coils wound around the conduit will receive high-frequency alternating current, generating electromagnetic induction in the wall of the conduit and thereby heating it with the currents induced in same. This will lead to a rise in the temperature of the wall until it is high enough to start burning the particles that are deposited on the inner face of the conduit. If the deposition surface is larger than the surface covered by the induction coils, two alternatives are provided: relative movement of the coils with respect to the conduit, or the

existence of various coils which are sequentially activated to heat the entire surface.

[0013] The invention relates to a self-regenerative electrostatic precipitator, of the type comprising a discharge electrode located inside a gas conduit for generating a corona discharge and for depositing solid particles in suspension in a gas stream circulating through the conduit in a deposition layer on the inner wall of the conduit. The self-regenerative electrostatic precipitator comprises at least one cleaning assembly arranged outside the conduit, each cleaning assembly having at least one induction coil wound around the conduit for heating the wall of the conduit by electromagnetic induction. The electrostatic precipitator comprises means for moving the at least one cleaning assembly along a section of the conduit.

[0014] The at least one induction coil of each cleaning assembly is surrounded by at least one layer of insulating material. The electrostatic precipitator comprises at least one securing element for fixing the discharge electrode inside the conduit.

[0015] In a preferred embodiment, the electrostatic precipitator comprises several cleaning assemblies the induction coils of which are activated together or sequentially.

[0016] The electrostatic precipitator can further comprise high-frequency alternating current generating means in the at least one induction coil.

BRIEF DESCRIPTION OF THE DRAWINGS

[0017] A series of drawings which helps to better understand the invention and is expressly related to an embodiment of said invention presented as a non-limiting example thereof is very briefly described below.

Figure 1 is a cross-section view of a cleaning and regeneration assembly.

Figure 2 shows a detailed cross-section view of the cleaning and regeneration assembly of Figure 1.

Figure 3 shows a cross-section view of the present invention.

DETAILED DISCLOSURE OF THE INVENTION

[0018] The particle retaining equipment used in the present invention is a cylindrical electrostatic precipitator. Figure 1 depicts a cross-section view of the electrostatic precipitator 10 formed by a discharge electrode 1, securing elements 2 for securing the discharge electrode and a gas conduit 3 through the inside of which the combustion gases circulate and in which the collected particles accumulate in a deposition layer 4 having an increasing

thickness. The regeneration system is formed by assemblies of induction coils 6, lead cable, and layers of insulating material 5.

[0019] The discharge electrode 1 generates the corona discharge for charging the solid particles in the combustion gases with particles 11 (the fume stream). In the same region, or in another one located thereafter, the electric field generated between the discharge electrode 1 and the wall of the conduit 3 (the deposition electrode) deflects the particles in suspension and causes them to be trapped, clean, particle-free gases 12 exiting the filtering system. The central discharge electrode 1 can be secured in various manners (separating arms, floating electrode, etc.), without this affecting the nature of the present invention. In the example shown in Figure 1, it is done by means of securing arms 2 built using an electrically insulating material.

[0020] When the electrostatic precipitator 10 is working, the particles will be retained, creating a deposition layer 4 having an increasing thickness adhered to the outer electrode. As this deposition layer 4 grows, the operation of the system worsens and the retaining efficiency gradually decreases due to the weakening of the electric field and to the increasing more likely reinsertion of particles deposited by erosion with the gas itself. It is therefore necessary to periodically eliminate or reduce the layer of dirt. To that end, the present invention incorporates a regeneration or self-cleaning system. It is formed by a series of induction coils 6 wound around the conduit 3. To protect them against the high temperature and to prevent unwanted electrical contacts they are internally and externally insulated with layers of insulating material 5. When the cleaning sequence is run, the induction coils 6 are subjected to a high-frequency alternating current, causing the induction electric currents in the body of the deposition electrode 3. As a result of this induction, the temperature of the conduit will increase up to values exceeding the ignition temperature of the particles deposited in the deposition layer 4. These particles, in the presence of oxygen that may be contained in combustion gases with particles 11 flowing through the inside of the conduit 3 and the high temperature in the wall, will burn and the mass and thickness of the deposition layer 4 will thereby be reduced.

[0021] The cleaning process is therefore based on burning the deposited particles again using the high temperature generated by means of electromagnetic induction on the deposition electrode.

[0022] The cleaning and regeneration system can be formed by several cleaning assemblies 7, as shown in Figure 1, where four independent cleaning assemblies 7 can be seen, each being formed by a wound induction coil 6 and two layers of insulating material 5. Figure 2 shows a view of detail A of Figure 1, in which a cleaning and regeneration assembly can be seen. The regeneration system is therefore formed by different assemblies of induction coils 6 and layers of insulating material 5. As many cleaning assemblies as required for burning the particles deposited on the entire wall of the conduit 3 can be used. Furthermore, the different cleaning assemblies do not have to be activated at the same time, but rather they can be activated in an alternating manner, depending on cleaning needs.

[0023] If required, there could be just one cleaning assembly 7 and it could move along the conduit 3 as shown in Figure 3. The operation of the invention is the same as that described above but now the regeneration or cleaning system moves vertically by means of a mechanical, electrical or magnetic mechanism to the area of the conduit that must be cleaned. Once the position is reached, it is electrically actuated, volatilizing the particles located in that area.

REFERENCES CITED IN THE DESCRIPTION

This list of references cited by the applicant is for the reader's convenience only. It does not form part of the European patent document. Even though great care has been taken in compiling the references, errors or omissions cannot be excluded and the EPO disclaims all liability in this regard.

Patent documents cited in the description

- JP2002047914B [0009]

Patentkrav

1. Selvregenererende elektrostatisk udskiller omfattende en afladningselektrode (1) lokaliseret inden i en gasledning (3) til at generere en koronaudladning og til at aflejre faste partikler i suspension i en gasstrøm (11), som cirkulerer igennem
- 5 ledningen (3) i et aflejringslag (4) på den indvendige væg af ledningen (3), omfattende mindst ét fastgørelseselement (2) for fastgørelse af afladningselektroden (1) inden i ledningen (3) **kendetegnet ved, at** den elektrostatisk udskiller (10) omfatter mindst én rensningsanordning (7) anbragt uden for og omkring ledningen (3) for opvarmning af den indvendige væg af
- 10 ledningen (3) med elektromagnetisk induktion, hvor hver rensningsanordning (7) er uafhængig af de andre og har mindst én induktionsspole (6) og mindst ét lag af isoleringsmateriale (5); og hvor den elektrostatisk udskiller (10) omfatter organ til at bevæge den mindst ene rensningsanordning (7) langs et afsnit af ledningen (3).
- 15
2. Den selvregenererende elektrostatisk udskiller ifølge krav 1, **kendetegnet ved, at** hver induktionsspole (6) af flerheden af rensningsanordninger (7) aktiveres sammen eller sekventielt.
- 20 3. Den selvregenererende elektrostatisk udskiller ifølge et hvilket som helst af de foregående krav, omfattende højfrekvens-vekselstrømsgenererende organ i mindst én induktionsspole (6).

DRAWINGS

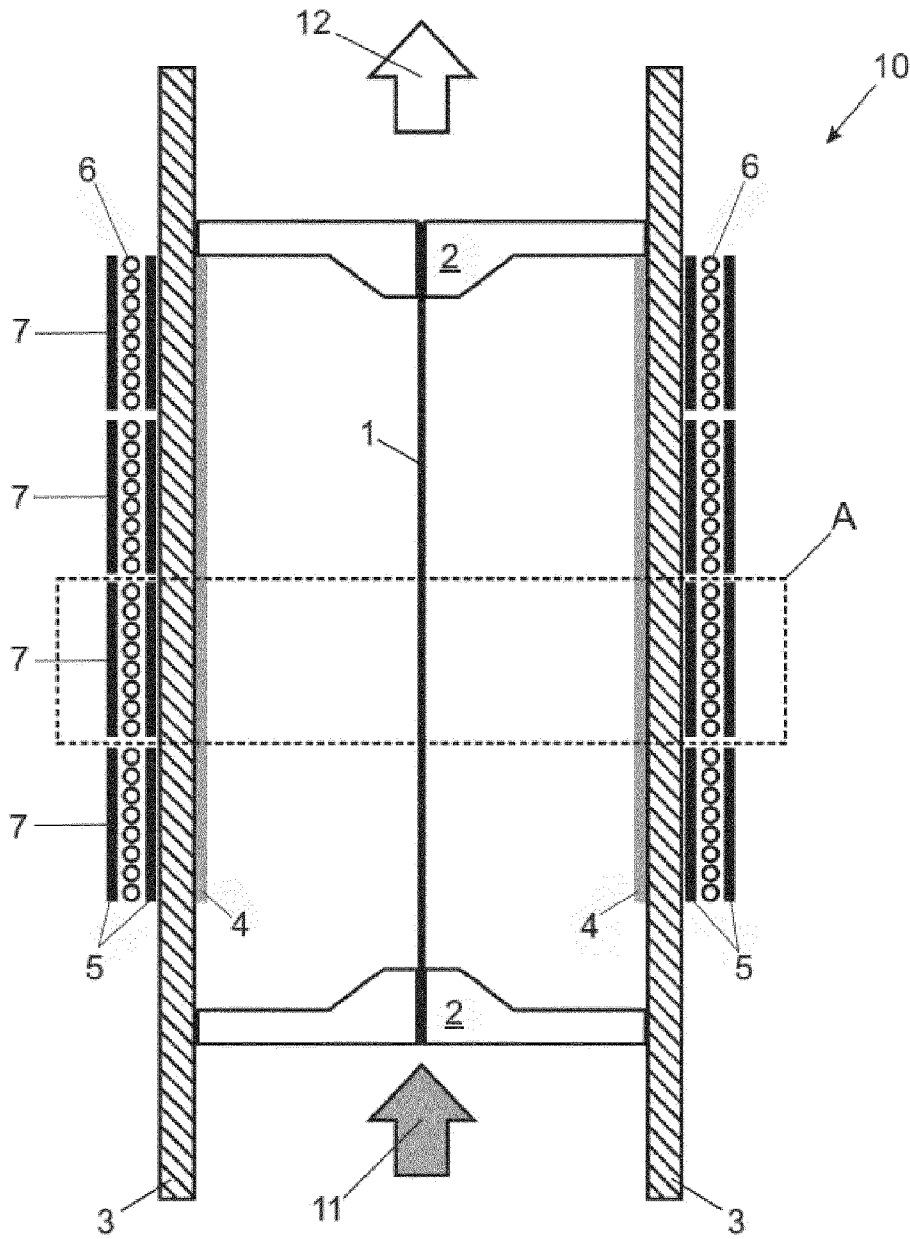

Fig. 1

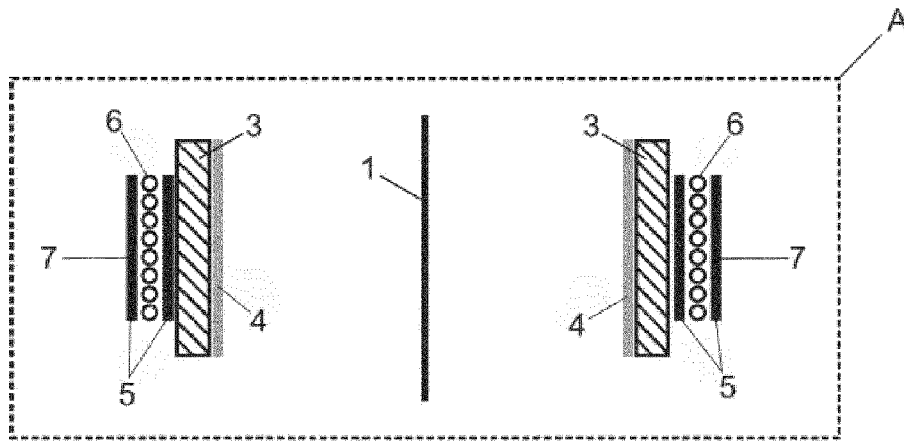

Fig. 2

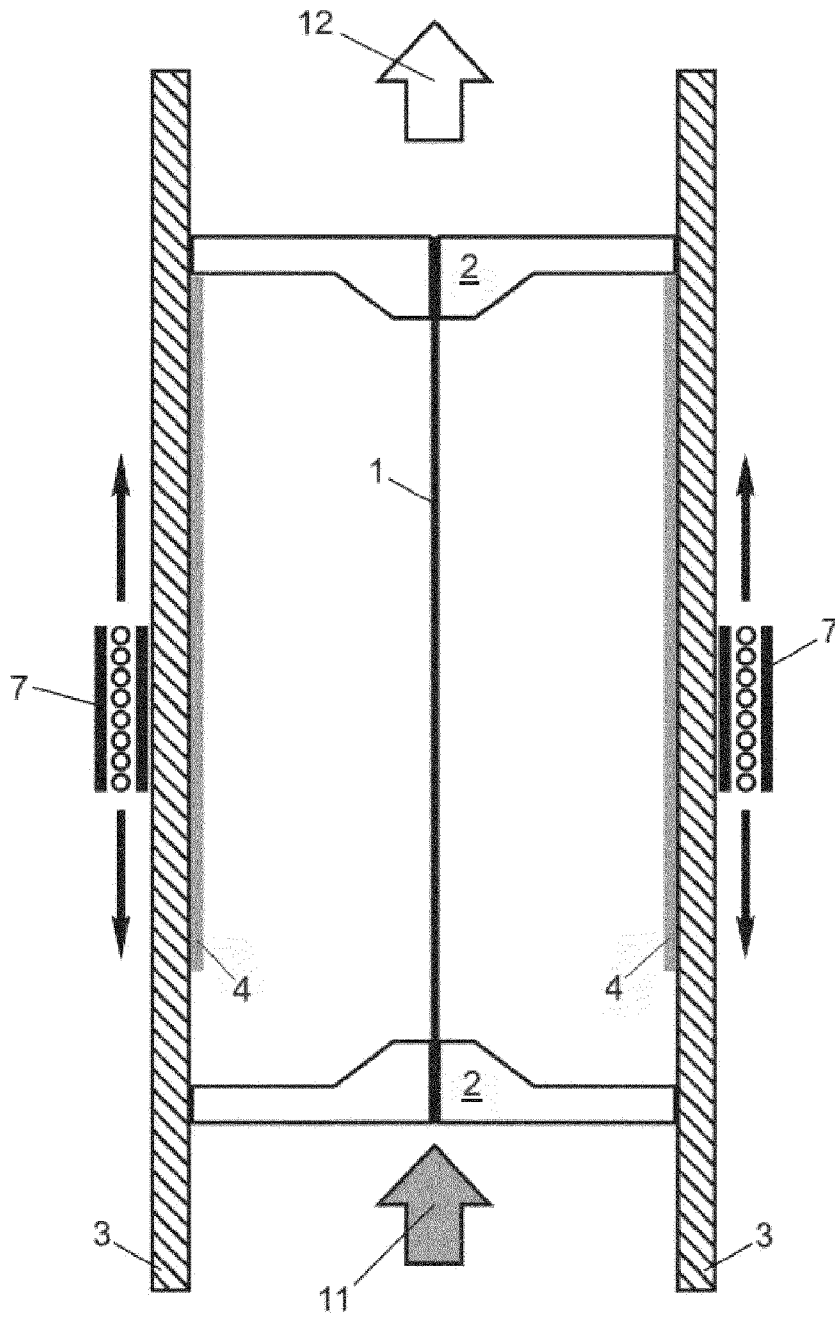

Fig. 3