

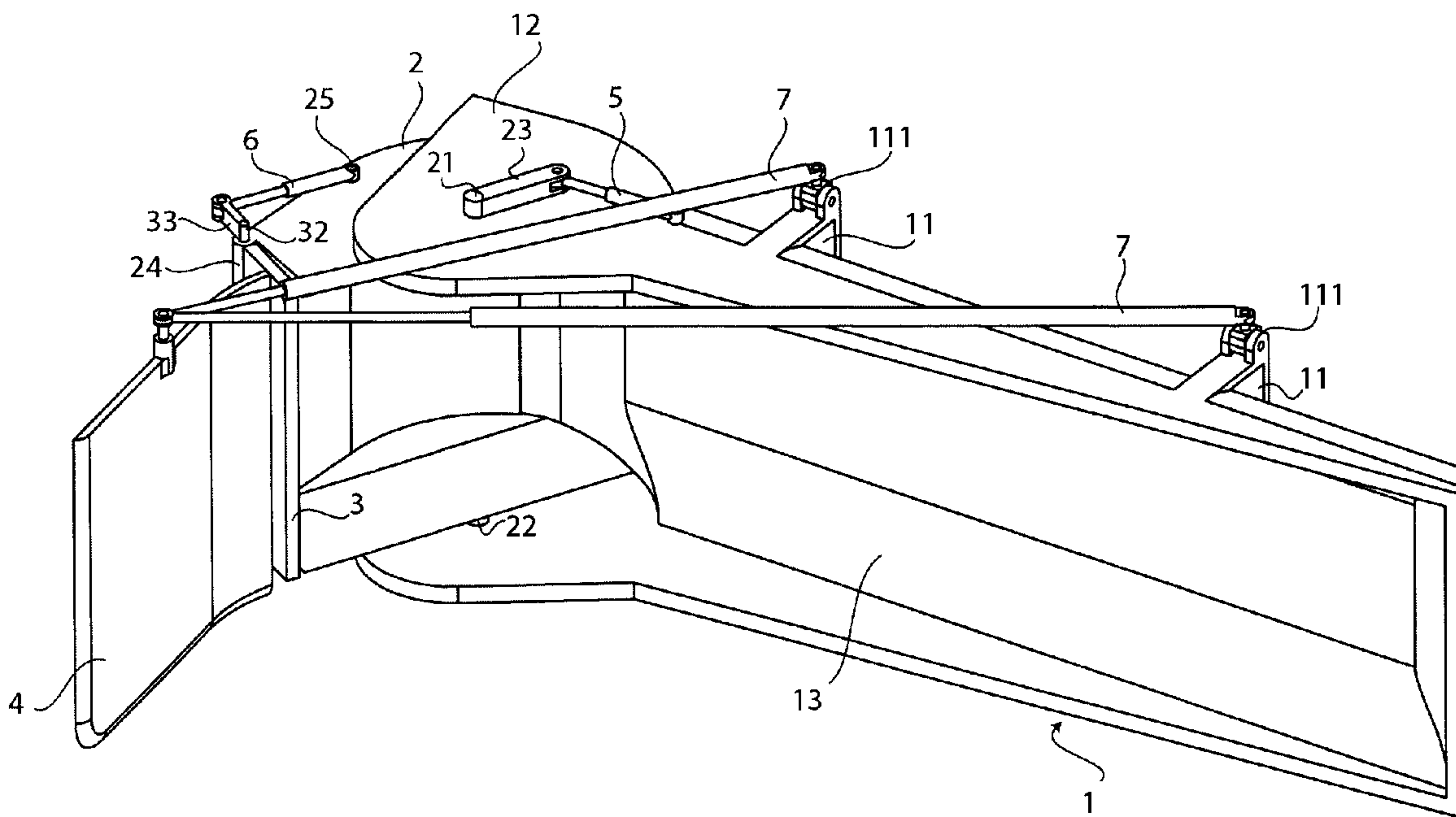

(22) Date de dépôt/Filing Date: 2012/01/19
 (41) Mise à la disp. pub./Open to Public Insp.: 2012/07/19
 (45) Date de délivrance/Issue Date: 2017/07/25
 (30) Priorité/Priority: 2011/01/19 (US61/434,157)

(51) Cl.Int./Int.Cl. *E01H 5/06* (2006.01)
 (72) Inventeur/Inventor:
 ANDIC, MIKE MILE, CA
 (73) Propriétaire/Owner:
 ANDIC, MIKE MILE, CA
 (74) Agent: MILTONS IP/P.I.

(54) Titre : ENSEMBLE CHASSE-NEIGE
 (54) Title: SNOW PLOW ASSEMBLY



(57) **Abrégé/Abstract:**

A snow plow assembly comprising a main plow body, at least one butterfly gate, at least one blocker and a diverter. The at least one butterfly gate and the at least one blocker are jointly connected to the main plow body and are controlled by actuators to be opened and closed. The actuators allow the users to control when to release or hold snow collected into the main plow body. This feature is used to prevent the buildup of high snow ridges in front of small pathways such as driveways.

ABSTRACT

A snow plow assembly comprising a main plow body, at least one butterfly gate, at least one blocker and a diverter. The at least one butterfly gate and the at least one
5 blocker are jointly connected to the main plow body and are controlled by actuators to be opened and closed. The actuators allow the users to control when to release or hold snow collected into the main plow body. This feature is used to prevent the buildup of high snow ridges in front of small pathways such as driveways.

Snow Plow Assembly

5 The current application claims a priority to the U.S. Provisional Patent application serial number 61/434,157 filed on January 19, 2011.

FIELD OF THE INVENTION

10 The present invention relates generally to a snow plow assembly that allows a user to control the release and collection of snow while plowing. More specifically, the snow plow assembly comprises a gate and a blocker to prevent snow from escaping the scoop cavity when needed.

15

BACKGROUND OF THE INVENTION

The present invention resolves the problem of blocking the side streets, driveway entrances, access to bus stops, etc. during the snow clearing operations in urban areas.
20 The present invention does so in a rapid, continuous fashion, automatically, without the input from a vehicle operator.

After the present invention removes the snow (in a "Standard" mode) from the street surface, it disposes the same to the side of the street in a selective fashion ("Selective" mode), by choosing to leave the side openings ("Windows"), like driveways,
25 cross-streets, bus stops, etc. free of snow deposits, thus not blocking those areas with the high snow ridges, common with present snow-cleaning technology.

The present invention is designed to be used for rapid and continuous removal of the snow from the streets and other paved surfaces in mostly municipal environment during the snow season. It will substantially improve efficiency, cost effectiveness,
30 environmental benefits and safety over the presently used technology.

As the leftover snow accumulates along the sidewalks and side street passages at intersections, the old technology leaves the job of cleaning the streets partially undone. In turn, a second vehicle is needed to clear the sidewalks and side street passages and other “windows”. It is therefore an object of the present invention to introduce a robotic machine for the selective disposal of snow removed from the street surface. In certain embodiments the plow truck may be guided and controlled by the GPS. The present invention resolves the problem of blocking the side streets, driveway entrances, access to bus stops, etc. during the snow clearing operations. The present invention does so in a rapid, continuous fashion automatically, without the input from a vehicle operator. It is a further object of the present invention to eliminate the need for a second vehicle, or same vehicle coming back to “open” the side street passage at the intersections, thus reducing the vehicle fleets. It is yet a further object of the present invention to reduce exhaust emissions, for all that is needed is one vehicle to do the work alone. The present invention eliminates the need for human involvement, thus safety and speed of operation are vastly improved. The present invention greatly improves the efficiency of the operation by eliminating any snow “leaks” or residue left behind, by using the newly designed “butterfly” gates. The present invention reduces the labor and operating costs for cleaning the streets.

20

BRIEF DESCRIPTION OF THE DRAWINGS

FIG. 1 is a perspective view of the present invention.

FIG. 2 is a perspective view of the present invention showing the butterfly gate and the blocker in a straight open position.

FIG. 3 is a perspective view of the present invention showing the blocker first moving into a closed position.

FIG. 4 is a perspective view of the present invention showing the butterfly gate closing towards the diverter.

FIG. 5 is a perspective view of the present invention showing the blocker reopening as the butterfly gate is fully closed to seal the gap between the butterfly gate and the diverter.

5

DETAIL DESCRIPTIONS OF THE INVENTION

All illustrations of the drawings are for the purpose of describing selected versions of the present invention and are not intended to limit the scope of the present invention.

The present invention is a snow plow assembly that is able to selectively plow snow towards the sides of a street. The objective is to prevent the build-up of high snow ridges onto the entrance of side streets, driveways, or any other small pathways directly adjacent to a street being plowed. The present invention is able to achieve this by introducing a gate system with an actuating system that can be controlled to allow snow to escape from the scoop cavity 13 or be contained within the scoop cavity 13 until released.

In reference to FIG.1, the present invention comprises of a main plow body 1, at least one butterfly gate 2, at least one blocker 3, a diverter 4, a gate actuator 5, a blocker actuator 6 and a pair of diverter supports 7. The main plow body 1, the at least one butterfly gate 2 and the at least one blocker 3 are jointly connected together and can be extended form a regularly shaped plow or compacted into a concave shape for retaining snow. The main plow body 1 is the main scoop of the plow assembly that collects and pushes snow to the side of the streets. The at least one butterfly gate 2 is used to interrupt the free flow of snow being scooped up and pushed to the side of a street by the main plow body 1. The blocker ensures a complete seal to prevent snow from escaping the at least one butterfly gate 2. The diverter 4 is an extension of the snow plow assembly that is able to further collect snow and ensure that snow is collected into the main plow body 1. In a closed and sealed position, the main plow body 1, the butterfly gate 2, the blocker 3, and the diverter 4 create one large, leak proof snow barrier for containing snow that otherwise would be disposed to the side of a street.

The main plow body **1** further comprises of a pair of truck mounts **11**, at least one gate mount **12** and a scoop cavity **13**. The at least one gate mount **12** is positioned on an end of the main plow body **1**. The at least one gate mount **12** provides a space for the at least one butterfly gate **2** to be mounted. The at least one gate mount **12** is a circular
5 hinge like cavity that is able to accommodate the at least one butterfly gate **2**. The pair of truck mounts **11** is vertically positioned brackets that are positioned on a rear side of the main plow body **1**. The pair of truck mounts **11** of evenly positioned on the rear side for even distribution of weight. The pair of truck mounts **11** provides the present invention with the ability to be mounted onto any truck for use. On the front side of the main plow
10 body **1** is the scoop cavity **13**. The scoop cavity **13** is a recessed space on the main plow body **1**.

The at least one butterfly gate **2** further comprises of a top gate axle **21**, a bottom gate axle **22**, a gate actuator segment **23**, and a blocker hinge **24**. Each of the butterfly gate **2s** are shaped like a loading hoe bucket that is positioned on its side. The top gate axle **21** and the bottom gate axle **22** provide the butterfly gate **2** a pivoting point in which it can be jointly mounted on to the at least one gate mount **12** of the main plow body **1**. The top gate axle **21** is upwardly extended from the at least one butterfly gate **2** and the bottom gate axle **22** is downwardly extended from the at least one butterfly gate **2**. The gate actuator segment **23** is perpendicularly extended from the top gate axle **21** and acts
15 similarly as a handle for the opening and closing of the butterfly gate **2**. The blocker hinge **24** is positioned on a first end of the butterfly gate **2** and is extended away from the main plow body **1**.

The at least one blocker **3** further comprises of an inner blocker hinge **24**, an inner blocker hinge axle **32**, and a blocker actuator segments **33**. The inner blocker hinge axle **32** is extended in concentric relationship to the inner blocker hinge **24**. Together, the inner blocker hinge axle **32** and the inner blocker hinge **24** is aligned and jointly connected to the at least one butterfly gate **2**. The blocker actuator segment **33**, in a similar fashion to the gate actuator segment **23** of the at least one butterfly gate **2**, is perpendicularly extended from the inner blocker hinge axle **32**.
25

30 In reference to FIG. **1**, the at least one butterfly gate **2**, the at least one blocker **3**, and the main plow body **1** is jointly connected in a chain to create the main section of the

snow plow assembly. The top gate axle **21** and the bottom gate axle **22** of the at least one butterfly gate **2** are jointly secured to the at least one gate mount **12** of the main plow body **1**. The top gate axle **21** is extended through the top side of the main plow body to allow the gate actuator segment **23** to be exposed and positioned atop the main plow body

5 **1**. The inner blocker hinge axle **32** is jointly secured to the blocker hinge **24** to secure to the at least one blocker **3** to the at least one butterfly gate **2**. The inner blocker hinge axle **32** is traversed through the blocker hinge **24** and further extends above. This allows the blocker actuator segment **33** to be positioned atop the at least one butterfly gate **2**. The gate actuator segment **23** and the blocker actuator segments **33** are positioned atop the

10 main plow body **1** and the at least one butterfly gate **2** to allow external forces to be applied for their open and release controls. To control the opening and closing of the at least one butterfly gate **2**, the main plow body **1** further comprises a gate actuator pin **14**. The gate actuator pin **14** is upwardly extended from the main plow body **1** to provide a pivoting and mounting point for the gate actuator **5**. The gate actuator **5** has a gate mount

15 end and a gate push end. The gate mount end of the gate actuator **5** is jointly connected to the gate actuator pin **14**. The gate push end is jointly connected to the gate actuator segment **23** of the at least one butterfly gate **2**. To control the opening and closing of the at least one blocker **3**, the at least one butterfly gate **2** further comprises a blocker actuator pin **25**. The blocker actuator pin **25** is upwardly extended from the at least one

20 butterfly gate **2** to provide a pivoting and mounting point for the blocker actuator **6**. The blocker actuator **6** has a blocker mount end and a blocker push end. The blocker mount end of the blocker actuator **6** is jointly connected to the blocker actuator pin **25**. The blocker push end is jointly connected to the blocker actuator segment **33** of the blocker.

In the preferred embodiment of the present invention, the gate actuator **5** and the blocker actuator **6** is a hydraulics piston system that is able to push and pull on the gate actuator segment **23** and the blocker actuator segment **33**, respectively. In other embodiments of the present invention, the gate actuator segment **23** and the blocker actuator segment **33** can be any other actuating means for pushing and pulling the gate actuator segment **23** and the block actuator segment **33**.

30 The pair of truck mounts **11** further comprises diverter support **7** hinges **111**. The diverter support hinges **111** are jointly connected to a top end of the pair of truck mounts

11. Each of the diverter supports 7 has a diverter mount end and a diverter push end. The diverter mount ends of the pair of diverter supports 7 are jointly connected to the diverter support hinges 111. The diverter push ends of the pair of diverter supports 7 are jointly connected to the diverter 4. In the preferred embodiment of the present invention, the
5 diverter supports 7 are hydraulic actuating systems that are able to control the positioning of the diverter 4.

In one embodiment of the present invention, the gate actuator 5, the blocker actuator 6, and the pair of diverter supports 7 are hydraulic systems that can be connected to a custom plow truck for control. However, in another embodiment of the present
10 invention, the hydraulic systems are controlled by a standalone system in which a remote can be extended into a truck for control and maneuvering of the snow plow assembly.

The present invention can operate in two complementary modes, a standard conventional mode and a GPS mode. The standard conventional mode allows the snow plow assembly to be used for the conventional removal of snow from the street pavement and deposited to the side curve area. The plow, angled to the curb is moved forward by a
15 vehicle controlled by a user. When the present invention is simply pushing snow from the street pavement to the side curb area, the main plow body 1, the at least one butterfly gate 2, and the blocker are all lined-up to form one continuous/straight configurations. As the plow moves forward along the right hand side of the street, the scraped snow glides from
20 the left-end of the plow to the right side of the plow.

As the plow nears driveway entrances, or any other small pathways, the snow plow assembly has the ability to reconfigure the positioning of the at least one butterfly gate 2 and the at least one blocker 3. In reference to FIG. 2-5, the snow plow assembly can convert into a closed position to collect snow away from small pathways to prevent
25 the buildup of high snow ridges in unwanted areas. First the at least one blocker 3 rotates ninety degrees towards the at least one butterfly gate 2 and interrupts the free flow of snow. At the same time, the butterfly gate 2 begins to pivot within the gate mounts 12 to enlarge the pocket for a larger scoop space for the aggregation of additional snow. As the butterfly gate 2 rotates to the full extent, the blocker reopens to seal the butterfly gate 2
30 with the diverter 4 to complete one large leak-proof snow barrier for containing snow that would otherwise be disposed in front of a small pathway as a high snow ridge. As a

result, the blockage of cross-streets, driveways, and other small pathways adjacent to the street being plowed is avoided.

In another embodiment of the present invention, the snow plow assembly may be mounted onto an automatic and unmanned plow truck for automatic plowing of streets. In
5 this embodiment of the present invention, the machine will be operated by means of GPS signal processor system that will utilize a signal/command interface and a control program. This allows the present invention to operate in GPS mode, where streets are detected and the snow plow assembly will automatically close and open correspondingly as the plow truck passes by small pathways such as driveways.

10 In another embodiment of the present invention, the snow plow assembly can comprise of two separate butterfly gates 2 and two separate blockers to be positioned on both ends of the main plow body 1. This allows the present invention to be operated for "left hand operation". This embodiment of the present invention is particularly useful for one way streets or left-hand drive streets. As a result, the users are not required to
15 disassemble the snow plow assembly to be flipped to the other side.

Although the invention has been explained in relation to its preferred embodiment, it is to be understood that many other possible modifications and variations can be made without departing from the spirit and scope of the invention as hereinafter claimed.

What is claimed is:

1. A snow plow assembly comprises,
 - a main plow body;
 - at least one butterfly gate;
 - at least one blocker;
 - a diverter;
 - a gate actuator;
 - a blocker actuator;
 - a pair of diverter supports;
 - the main plow body comprises a pair of truck mounts, at least one gate mount, and a scoop cavity;
 - the pair of truck mounts comprises a pair of diverter support hinges wherein the pair of diverter supports connect the diverter support hinges and the diverter;
 - the at least one butterfly gate comprises a top gate axle, a bottom gate axle, a gate actuator segment, and a blocker hinge;
 - the gate actuator is a hydraulic piston system for pushing and pulling the gate actuator segment;
 - the at least one blocker comprises an inner blocker hinge, an inner blocker hinge axle, and a blocker actuator segment;
 - the blocker actuator is a hydraulic piston system for pushing and pulling the blocker actuator segment;
 - the top gate axle and the bottom gate axle of the at least one butterfly gate being jointly secured to the at least one gate mount of the main plow body;
 - the top gate axle extending through a top side of the main plow body;
 - the gate actuator segment being positioned atop the main plow body;
 - the inner blocker hinge axle being jointly secured to the blocker hinge of the at least one butterfly gate;
 - the inner blocker hinge axle being traversed through the blocker hinge; and
 - the blocker actuator segment being positioned atop the at least one butterfly gate.

2. The snow plow assembly as claimed in claim 1 comprises,
 - the at least one gate mount being positioned on an end of the main plow body;
 - the pair of truck mounts being vertically positioned on a rear side of the main plow body; and
 - the scoop cavity being a recessed space on the main plow body.
3. The snow plow assembly as claimed in claim 1 comprises,
 - the top gate axle being upwardly extended from the at least one butterfly gate;
 - the bottom gate axle being downwardly extended from the at least one butterfly gate;
 - the gate actuator segment being perpendicularly extended from the top gate axle;
 - and
 - the blocker hinge being positioned on a first gate end.
4. The snow plow assembly as claimed in claim 1 comprises,
 - the inner blocker hinge axle being extended in concentric relationship to the inner blocker hinge; and
 - the blocker actuator segment being perpendicularly extended from the inner blocker hinge axle.
5. The snow plow assembly as claimed in claim 1 comprises,
 - the main plow body further comprises a gate actuator pin;
 - the gate actuator having a gate mount end and a gate push end;
 - the gate mount end being jointly connected to the gate actuator pin; and
 - the gate push end being jointly connected to the gate actuator segment.
6. The snow plow assembly as claimed in claim 1 comprises,
 - the at least one butterfly gate comprises a blocker actuator pin;
 - the blocker actuator having a blocker mount end and a blocker push end;
 - the blocker mount end being jointly connected to the blocker actuator pin; and
 - the blocker push end being jointly connected to the blocker actuator segment.
7. The snow plow assembly as claimed in claim 1 comprises,

the pair of truck mounts comprises the pair of diverter support hinges;
 the diverter support hinges being jointly connected to a top end of the pair of truck mounts;

each of the diverter supports having a diverter mount end and a diverter push end;

the diverter mount ends of the pair of diverter supports being jointly connected to the diverter support hinges; and

the diverter push ends of the pair of diverter supports being jointly connected to the diverter.

8. A snow plow assembly comprises,

a main plow body;

at least one butterfly gate;

at least one blocker;

a diverter;

a gate actuator;

a blocker actuator;

a pair of diverter supports;

the at least one butterfly gate and the at least one blocker and the main plow body are jointly connected in a chain to form a main section of the snow plow assembly;

the main plow body comprises a pair of truck mounts, at least one gate mount, and a scoop cavity;

the pair of truck mounts comprises a pair of diverter support hinges wherein the pair of diverter supports connect the diverter support hinges and the diverter;

the at least one butterfly gate comprises a top gate axle, a bottom gate axle, a gate actuator segment, and a blocker hinge;

the gate actuator is a hydraulic piston system for pushing and pulling the gate actuator segment;

the at least one blocker comprises an inner blocker hinge, an inner blocker hinge axle, and a blocker actuator segment;

the blocker actuator is a hydraulic piston system for pushing and pulling the blocker actuator segment; and

the top gate axle and the bottom gate axle of the at least one butterfly gate being jointly secured to the at least one gate mount of the main plow body.

9. The snow plow assembly as claimed in claim 8 comprises,

the at least one gate mount being positioned on an end of the main plow body;

the pair of truck mounts being vertically positioned on a rear side of the main plow body; and

the scoop cavity being a recessed space on the main plow body.

10. The snow plow assembly as claimed in claim 8 comprises,

the top gate axle extending through a top side of the main plow body;

the gate actuator segment being positioned atop the main plow body;

the inner blocker hinge axle being jointly secured to the blocker hinge of the at least one butterfly gate;

the inner blocker hinge axle being traversed through the blocker hinge;

the blocker actuator segment being positioned atop the at least one butterfly gate;

the top gate axle being upwardly extended from the at least one butterfly gate;

the bottom gate axle being downwardly extended from the at least one butterfly gate;

the gate actuator segment being perpendicularly extended from the top gate axle;

and

the blocker hinge being positioned on a first gate end.

11. The snow plow assembly as claimed in claim 8 comprises,

the top gate axle extending through a top side of the main plow body;

the gate actuator segment being positioned atop the main plow body;

the inner blocker hinge axle being jointly secured to the blocker hinge of the at least one butterfly gate;

the inner blocker hinge axle being traversed through the blocker hinge;

the blocker actuator segment being positioned atop the at least one butterfly gate;

the inner blocker hinge axle being extended in concentric relationship to the inner blocker hinge; and

the blocker actuator segment being perpendicularly extended from the inner blocker hinge axle.

12. The snow plow assembly as claimed in claim 8 comprises,

the top gate axle extending through a top side of the main plow body;

the gate actuator segment being positioned atop the main plow body;

the inner blocker hinge axle being jointly secured to the blocker hinge of the at least one butterfly gate;

the inner blocker hinge axle being traversed through the blocker hinge;

the blocker actuator segment being positioned atop the at least one butterfly gate;

the main plow body further comprises a gate actuator pin;

the gate actuator having a gate mount end and a gate push end;

the gate mount end being jointly connected to the gate actuator pin; and

the gate push end being jointly connected to the gate actuator segment.

13. The snow plow assembly as claimed in claim 8 comprises,

the top gate axle extending through a top side of the main plow body;

the gate actuator segment being positioned atop the main plow body;

the inner blocker hinge axle being jointly secured to the blocker hinge of the at least one butterfly gate;

the inner blocker hinge axle being traversed through the blocker hinge;

the blocker actuator segment being positioned atop the at least one butterfly gate;

the at least one butterfly gate comprises a blocker actuator pin;

the blocker actuator having a blocker mount end and a blocker push end;

the blocker mount end being jointly connected to the blocker actuator pin; and

the blocker push end being jointly connected to the blocker actuator segment.

14. The snow plow assembly as claimed in claim 9 comprises,

the top gate axle extending through a top side of the main plow body;

the gate actuator segment being positioned atop the main plow body;

the inner blocker hinge axle being jointly secured to the blocker hinge of the at least one butterfly gate;

the inner blocker hinge axle being traversed through the blocker hinge;

the blocker actuator segment being positioned atop the at least one butterfly gate;

the pair of truck mounts comprises the pair of diverter support hinges;

the diverter support hinges being jointly connected to a top end of the pair of truck mounts;

each of the diverter supports having a diverter mount end and a diverter push end;

the diverter mount ends of the pair of diverter supports being jointly connected to the diverter support hinges; and

the diverter push ends of the pair of diverter supports being jointly connected to the diverter.

15. A snow plow assembly comprises,

a main plow body;

at least one butterfly gate;

at least one blocker;

a diverter;

a gate actuator;

a blocker actuator;

a pair of diverter supports;

the main plow body comprises a pair of truck mounts, at least one gate mount, and a scoop cavity;

the at least one butterfly gate comprises a top gate axle, a bottom gate axle, a gate actuator segment, and a blocker hinge;

the at least one blocker comprises an inner blocker hinge, an inner blocker hinge axle, and a blocker actuator segment;

the top gate axle extending through a top side of the main plow body;

the at least one gate mount being positioned on an end of the main plow body;

the pair of truck mounts being vertically positioned on a rear side of the main

plow body;

the scoop cavity being a recessed space on the main plow body;

the top gate axle and the bottom gate axle of the at least one butterfly gate being jointly secured to the at least one gate mount of the main plow body;

the gate actuator segment being positioned atop the main plow body;

the inner blocker hinge axle being jointly secured to the blocker hinge of the at least one butterfly gate;

the inner blocker hinge axle being traversed through the blocker hinge;

the blocker actuator segment being positioned atop the at least one butterfly gate;

the main plow body further comprises a gate actuator pin;

the gate actuator having a gate mount end and a gate push end;

the gate mount end being jointly connected to the gate actuator pin;

the gate push end being jointly connected to the gate actuator segment;

the at least one butterfly gate comprises a blocker actuator pin;

the blocker actuator having a blocker mount end and a blocker push end;

the blocker mount end being jointly connected to the blocker actuator pin;

the blocker push end being jointly connected to the blocker actuator segment;

the top gate axle being upwardly extended from the at least one butterfly gate;

the bottom gate axle being downwardly extended from the at least one butterfly gate;

the gate actuator segment being perpendicularly extended from the top gate axle;

and

the blocker hinge being positioned on a first gate end.

16. The snow plow assembly as claimed in claim 15 comprises,

the inner blocker hinge axle being extended in concentric relationship to the inner blocker hinge; and

the blocker actuator segment being perpendicularly extended from the inner blocker hinge axle.

17. The snow plow assembly as claimed in claim 15 comprises,
- the pair of truck mounts comprises diverter support hinges;
 - the diverter support hinges being jointly connected to a top end of the pair of truck mounts;
 - each of the diverter supports having a diverter mount end and a diverter push end;
 - the diverter mount ends of the pair of diverter supports being jointly connected to the diverter support hinges; and
 - the diverter push ends of the pair of diverter supports being jointly connected to the diverter.
18. A snow plow assembly comprises,
- a main plow body;
 - at least one butterfly gate;
 - at least one blocker;
 - a diverter;
 - a gate actuator;
 - a blocker actuator;
 - a pair of diverter supports;
 - the main plow body comprises a pair of truck mounts, at least one gate mount, and a scoop cavity;
 - the at least one butterfly gate comprises a top gate axle, a bottom gate axle, a gate actuator segment, and a blocker hinge;
 - the at least one blocker comprises an inner blocker hinge, an inner blocker hinge axle, and a blocker actuator segment;
 - the at least one gate mount being positioned on an end of the main plow body;
 - the pair of truck mounts being vertically positioned on a rear side of the main plow body;
 - the scoop cavity being a recessed space on the main plow body;
 - the pair of truck mounts comprises diverter support hinges;
 - the diverter support hinges being jointly connected to a top end of the pair of truck mounts;

each of the diverter supports having a diverter mount end and a diverter push end;

the diverter mount ends of the pair of diverter supports being jointly connected to the diverter support hinges;

the diverter push ends of the pair of diverter supports being jointly connected to the diverter;

the top gate axle and the bottom gate axle of the at least one butterfly gate being jointly secured to the at least one gate mount of the main plow body;

the top gate axle extending through a top side of the main plow body;

the gate actuator segment being positioned atop the main plow body;

the inner blocker hinge axle being jointly secured to the blocker hinge of the at least one butterfly gate;

the inner blocker hinge axle being traversed through the blocker hinge; and

the blocker actuator segment being positioned atop the at least one butterfly gate.

19. The snow plow assembly as claimed in claim 18 comprises,

the top gate axle being upwardly extended from the at least one butterfly gate;

the bottom gate axle being downwardly extended from the at least one butterfly gate;

the gate actuator segment being perpendicularly extended from the top gate axle;

and

the blocker hinge being positioned on a first gate end.

20. The snow plow assembly as claimed in claim 18 comprises,

the inner blocker hinge axle being extended in concentric relationship to the inner blocker hinge; and

the blocker actuator segment being perpendicularly extended from the inner blocker hinge axle.

21. The snow plow assembly as claimed in claim 18 comprises,

the main plow body further comprises a gate actuator pin;

the gate actuator having a gate mount end and a gate push end;
the gate mount end being jointly connected to the gate actuator pin; and
the gate push end being jointly connected to the gate actuator segment.

22. The snow plow assembly as claimed in claim 18 comprises,

the at least one butterfly gate comprises a blocker actuator pin;
the blocker actuator having a blocker mount end and a blocker push end;
the blocker mount end being jointly connected to the blocker actuator pin; and
the blocker push end being jointly connected to the blocker actuator segment.

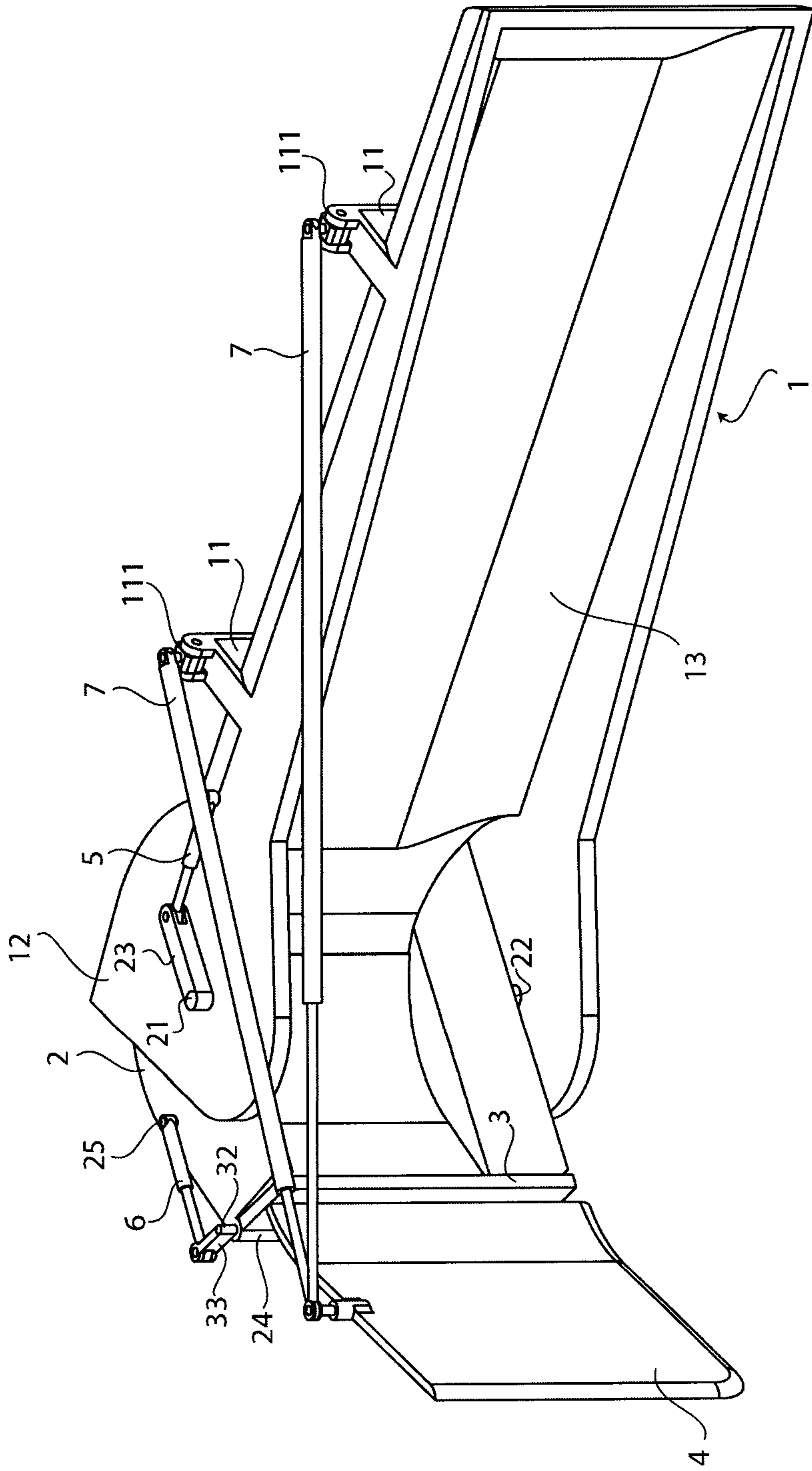

FIG. 1

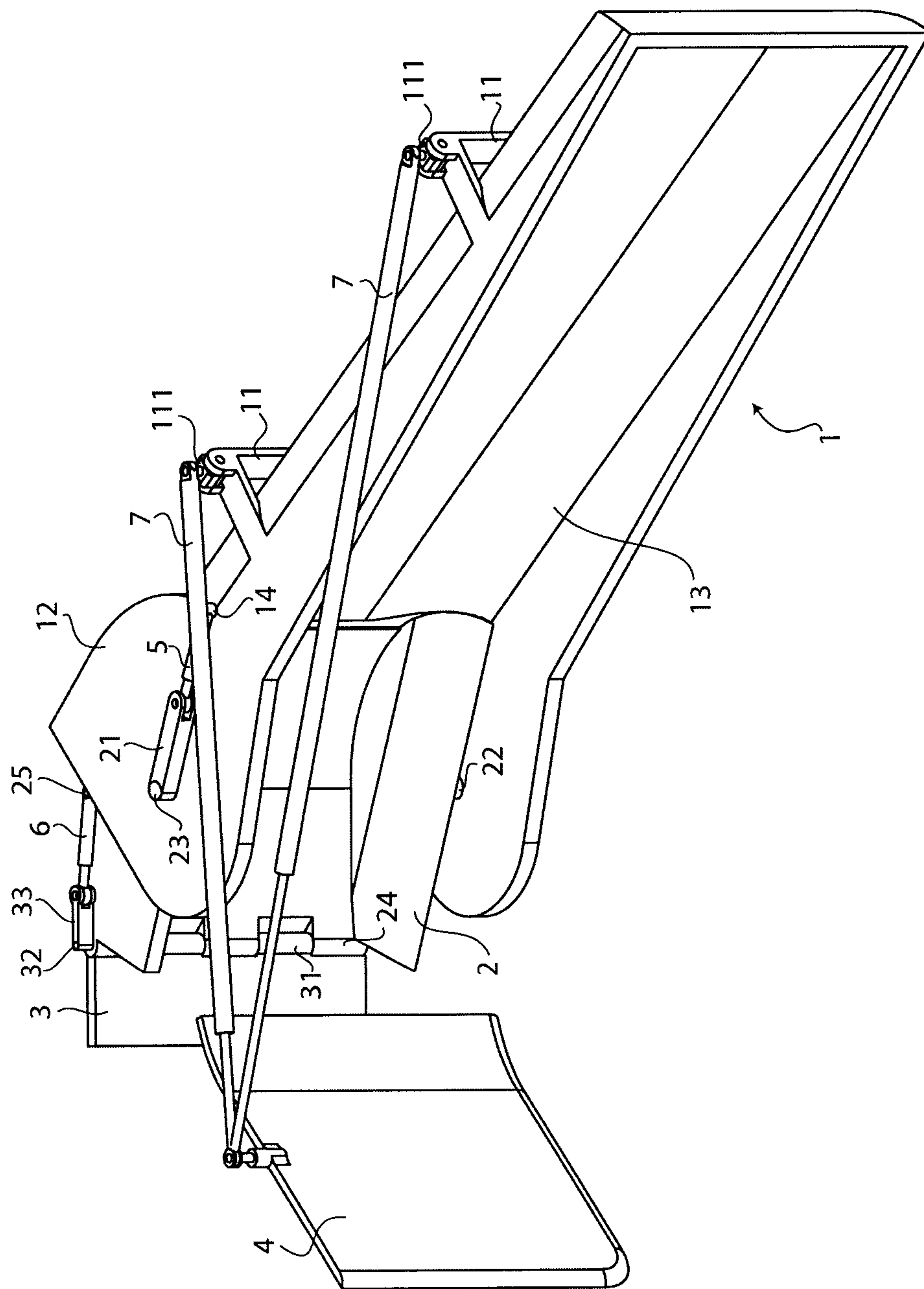

FIG. 2

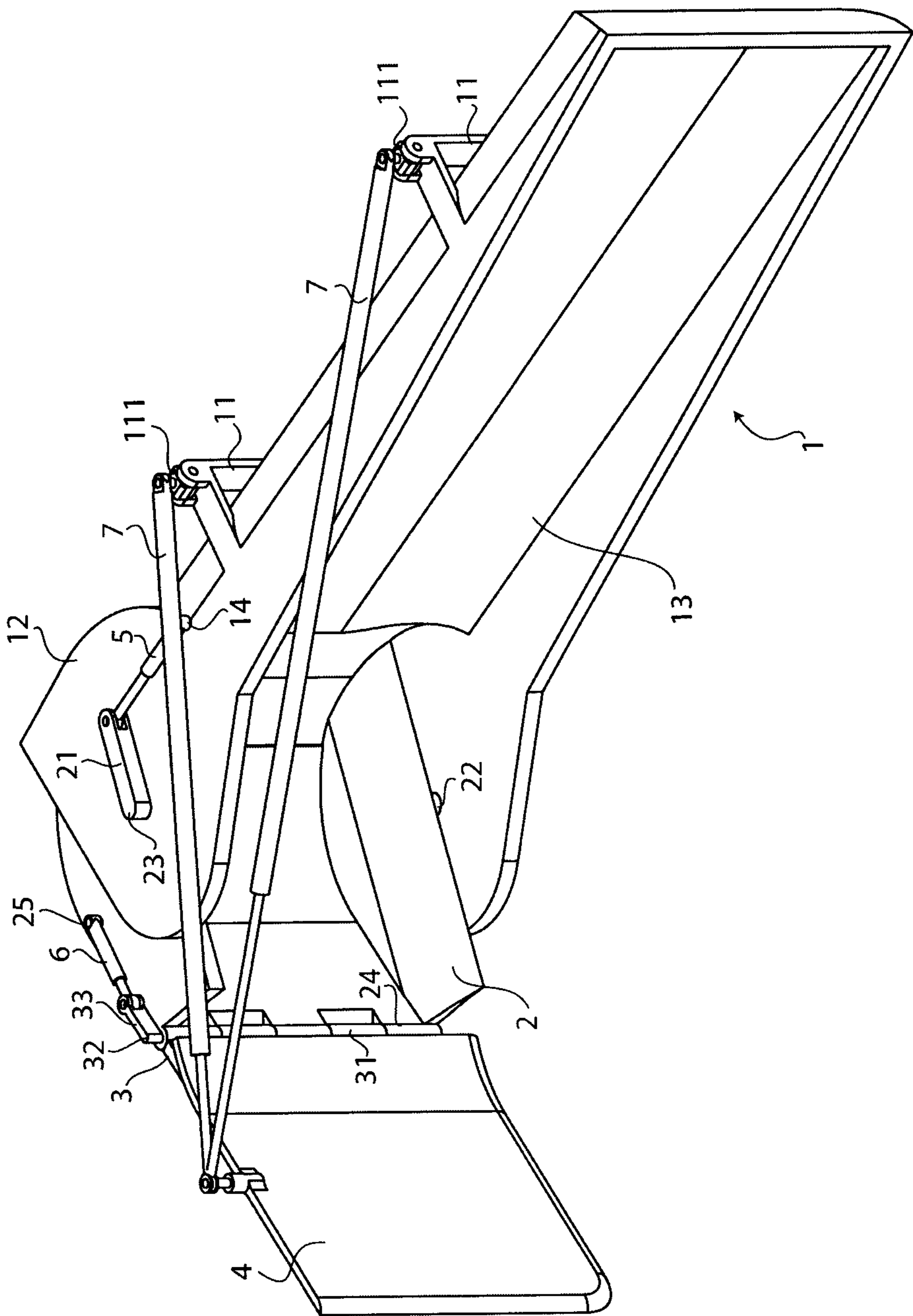

FIG. 5

