



- (51) International Patent Classification:  
A61B 5/157 (2006.01)
- (21) International Application Number:  
PCT/US2016/013481
- (22) International Filing Date:  
14 January 2016 (14.01.2016)
- (25) Filing Language: English
- (26) Publication Language: English
- (30) Priority Data:  
62/125,105 14 January 2015 (14.01.2015) US  
62/197,298 27 July 2015 (27.07.2015) US  
14/996,089 14 January 2016 (14.01.2016) US
- (72) Inventor; and
- (71) Applicant : HARTLEY, Frank, Thomas [US/US]; 529 E. Las Flores Ave., Arcadia, CA 91006 (US).
- (74) Agent: WALKER, James, A.; Kaplan, Breyer, Schwarz & Ottesen, LLP, 100 Matawan Road, Suite 120, Matawan, NJ 07747 (US).
- (81) Designated States (unless otherwise indicated, for every kind of national protection available): AE, AG, AL, AM, AO, AT, AU, AZ, BA, BB, BG, BH, BN, BR, BW, BY,

BZ, CA, CH, CL, CN, CO, CR, CU, CZ, DE, DK, DM, DO, DZ, EC, EE, EG, ES, FI, GB, GD, GE, GH, GM, GT, HN, HR, HU, ID, IL, IN, IR, IS, JP, KE, KG, KN, KP, KR, KZ, LA, LC, LK, LR, LS, LU, LY, MA, MD, ME, MG, MK, MN, MW, MX, MY, MZ, NA, NG, NI, NO, NZ, OM, PA, PE, PG, PH, PL, PT, QA, RO, RS, RU, RW, SA, SC, SD, SE, SG, SK, SL, SM, ST, SV, SY, TH, TJ, TM, TN, TR, TT, TZ, UA, UG, US, UZ, VC, VN, ZA, ZM, ZW.

- (84) Designated States (unless otherwise indicated, for every kind of regional protection available): ARIPO (BW, GH, GM, KE, LR, LS, MW, MZ, NA, RW, SD, SL, ST, SZ, TZ, UG, ZM, ZW), Eurasian (AM, AZ, BY, KG, KZ, RU, TJ, TM), European (AL, AT, BE, BG, CH, CY, CZ, DE, DK, EE, ES, FI, FR, GB, GR, HR, HU, IE, IS, IT, LT, LU, LV, MC, MK, MT, NL, NO, PL, PT, RO, RS, SE, SI, SK, SM, TR), OAPI (BF, BJ, CF, CG, CI, CM, GA, GN, GQ, GW, KM, ML, MR, NE, SN, TD, TG).

**Published:**

- with international search report (Art. 21(3))
- before the expiration of the time limit for amending the claims and to be republished in the event of receipt of amendments (Rule 48.2(h))



WO 2016/115397 A1

(54) Title: APPARATUS FOR DRAWING OF A BODILY FLUID AND METHOD THEREFOR

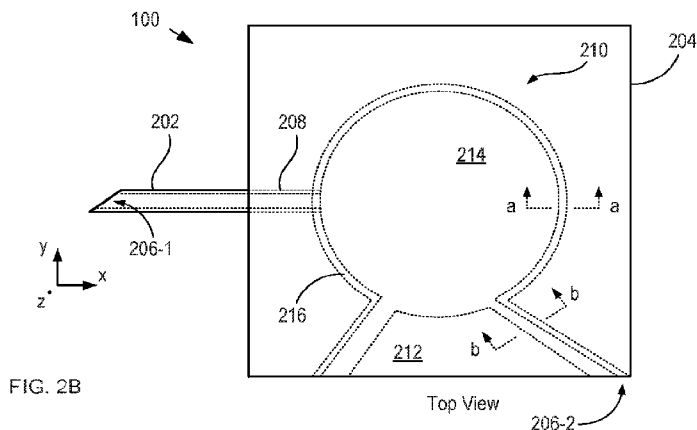

(57) Abstract: A sample holder that enables mid-infrared spectroscopy of a test sample using mid-infrared light is disclosed. The sample holder includes an inlet port and a sample chamber that comprises a sample region and a capillary channel that fluidically couples the inlet port and the sample region. The capillary channel is characterized by a higher capillary force than the sample region. As a result, when the inlet port is put in contact with a liquid containing the test sample, the liquid is drawn into the sample region without the formation of bubbles that could obscure the optical analysis. In some embodiments, the inlet port is the free end of a draw tube having an outer diameter that is smaller than the minimum spacing between pain receptors at a draw site on a patient, which mitigates pain felt by the patient due to insertion of the draw tube at the draw site.

## **Apparatus for Drawing of a Bodily Fluid and Method Therefor**

### **Cross Reference to Related Applications**

[0001] This application claims the benefit of U.S. Provisional Application Serial Number 62/125,105, filed January 14, 2015, entitled "Methods for the Painless Drawing of Aliquots of Bodily Fluids and Their Analytics," and U.S. Provisional Application Serial Number 62/197,298, filed July 27, 2015, entitled "A Micro-Cuvette for the Painless Drawing of Aliquots of Bodily Fluids and Their Optical Analysis," (Attorney Docket: 550-006PR2), each of which is incorporated herein by reference. If there are any contradictions or inconsistencies in language between this application and one or more of the cases that have been incorporated by reference that might affect the interpretation of the claims in this case, the claims in this case should be interpreted to be consistent with the language in this case.

### **Field of the Invention**

[0002] The present invention relates to analytical chemistry technology in general, and, more particularly, to chemical analysis of fluids and fluid-like materials.

### **Background of the Invention**

[0003] An assessment of patient health is often based, in part, on the chemistry of one or more bodily fluids of that patient, such as blood, urine, spittle, tears, *etc.* Blood, for example, provides many key health markers, for example, such as hemoglobin (red blood cell) count, white-blood-cell (WBC) count, nitrogen level, glucose level, and ion concentration, among others.

[0004] Unfortunately, the collection of bodily fluids in volumes sufficient for reliable testing can be challenging. For example, conventional blood-test samples are usually drawn *in-vivo* using large medical syringes, which can cause significant patient distress – before, during, and after the drawing procedure.

[0005] Blood drawing methods are highly manual in nature and typically require trained personnel who can properly select a vein suitable for needle insertion and extract the blood into one or more sample vials. It is not uncommon that, during a blood draw, the skin is punctured but the target vein is missed. In such cases, the needle must be removed

and reinserted in a second attempt to hit the proper vein. In other cases, the needle is inserted into the target vein too deeply. As a result, the other end wall of the target vein is punctured, which can cause blood leakage under the skin to give rise to a hematoma.

[0006] To avoid some of the complications of in-vivo blood drawing, a blood sample can be acquired *ex-vivo* using a lancet to puncture the skin at a location that can provide a sufficient amount of blood – typically, a fingertip. Unfortunately, this method also has many disadvantages. First, lancet-based blood drawing typically yields only a small amount of blood before clotting occurs. The presence of a blood clot in a blood sample is a cause for rejection of the sample because testing of partially clotted blood can lead to irregularities in some blood tests. Second, sites that are prone to provide more blood when pierced also tend to have a high concentration of pain receptors. As a result, a puncture of the skin at these sites typically causes the patient more pain.

[0007] Both blood-drawing methods cause significant pain to the patient, weep internally and externally afterward, give rise to potential infection sites, and are prone to bruising and prolonged tenderness. As a result, patients are understandably unenthusiastic about having their blood drawn.

[0008] Further, a typical test panel requires several milliliters (or tens of milliliters) of blood. This is true for other bodily fluids – urine, spittle, synovial fluid, moist solids, *etc.*, which, in many cases, can be difficult to collect from the patient in sufficient volume.

[0009] The need to enable sophisticated analysis of a bodily fluid using only a small volume of fluid and without subjecting a patient to significant pain or risk of complication remains, as yet, unmet.

### **Summary of the Invention**

[0010] The present invention enables analysis of a test sample without some of the costs and disadvantages of the prior art. Embodiments of the present invention enable content-rich analysis of small-volume test samples of liquids or moist solids, such as chemical solutions, petroleum products (*e.g.*, fuel oils, crude oil, waste oils, *etc.*), bodily fluids (*e.g.*, blood, urine, spittle, sweat, tears, saliva, stool, *etc.*), foodstuffs (*e.g.*, dairy products, pastes, sauces, *etc.*), cosmetic compounds, and the like, thereby obviating the need for drawing and storing large volumes of material.

**[0011]** The present invention encompasses two key inventive aspects: 1) a sample holder that is easy to fabricate and low cost, but that enables spectroscopic analysis of a test sample using mid-infrared radiation; and 2) a microfluidic system that is dimensioned and arranged to facilitate the rapid filling of a chamber with a liquid without inducing bubbles in the liquid, where the force that draws the liquid into the chamber is capillary force.

**[0012]** An illustrative embodiment of the present invention is a compact sample holder operative for drawing blood from a draw site on a patient via capillary force and without causing bubbles to form during the draw. The sample holder comprises a draw tube and a small-volume, two-part sample chamber, which includes a sample region and a capillary channel. The sample holder is transmissive for mid-infrared radiation, which enables spectroscopic analysis of the blood over a short interaction length with the test sample. As a result, the sample holder requires only a small-volume sample chamber, which mitigates the need for drawing large volumes of blood from the patient. The patient, therefore, is not subjected to significant pain, discomfort, or long draw times.

**[0013]** The draw tube is a stainless-steel hypodermic needle having an outer diameter that is approximately 125 microns - smaller than the normal minimum spacing of pain receptors in the human body. The inner diameter of the draw tube is approximately 50 microns, which gives rise to two-phase flow of blood through the draw tube, wherein blood cells are concentrated in the central region of the flow while a sheath of plasma flow surrounds the blood cells.

**[0014]** The draw tube is fluidically coupled with sample region via the capillary channel, which extends around the perimeter of the sample region. The sample chamber is formed in a body that is made of float-zone silicon. Because float-zone silicon is substantially transparent to mid-infrared radiation, by virtue of its extremely low impurity concentration, its use as the structural material of the body enables sample analysis using mid-infrared light, which is a spectral-information-rich wavelength region for most biological materials. In some embodiments, a different material that is substantially transparent to mid-infrared light is used as the structural material. In some embodiments, the body enables spectroscopic analysis of the test sample using radiation other than mid-infrared radiation and the sample chamber is transmissive for that radiation.

[0015] The sample chamber is a circular region having a volume that is equivalent to approximately  $1/50^{\text{th}}$  of a drop of blood. It is defined by top and bottom surfaces that are closely spaced and substantially parallel, and a sidewall that is oriented an angle of approximately  $45^{\circ}$  to the top and bottom surfaces. The spacing of the top and bottom surfaces in the sample region enable development of capillary force for drawing liquid into the sample region, while the bottom surface and the sidewall collectively define a small triangular cross-section for the capillary channel, which fluidically couples the sample chamber with the draw tube. The small cross-sectional spacing of the sample region and capillary channel gives rise to a strong capillary force that enhances the capillary drawing capability of the sample holder and inhibits the formation of bubbles in the sample as it is drawn into the sample chamber. In some embodiments, the angle of the sidewall, with respect to the top and bottom surfaces, is less than  $45^{\circ}$ . In some embodiments, the sidewall is a non-planar surface.

[0016] In some embodiments, the sample holder does not include a draw tube but, instead, draws liquid through an inlet port located on a side of the body.

[0017] An illustrative method for analyzing a sample of bodily fluid comprises: drawing the sample into the sample chamber via capillary force, transmitting mid-infrared light through the body and sample, detecting the spectrum of the light after it has passed through the sample, removing the contribution of the absorption spectrum of water from the measured absorption spectrum of the sample, and comparing the resultant normalized spectrum to stored spectra for one or more analytes of interest.

[0018] In some embodiments, the sample region includes one or more regions that are functionalized with a reagent that gives rise to a visible signal based on an analyte of interest.

[0019] In some embodiments, the sample chamber includes a microfluidic system that includes one or more microfluidic elements, such as filters, mixers, separators, and the like.

[0020] In some embodiments, the body includes an optical element, such as a diffractive element, holographic element, refractive lens, and the like.

[0021] In some embodiments, the sample chamber includes one or more electrodes that enable electrochemical analysis of the sample.

[0022] An embodiment of the present invention is a sample holder for holding a test sample, the sample holder comprising: an inlet port; and a sample chamber that includes a first surface that is transmissive for radiation having a wavelength within the range of approximately 2.5 microns to approximately 12.5 microns, the sample chamber having a sample region and a capillary channel that fluidically couples the inlet port and the sample region; wherein the sample region is characterized by a first capillary force for a first liquid and the capillary channel is characterized by a second capillary force for the first liquid, and wherein the second capillary force is higher than the first capillary force such that the capillary channel is operative for drawing the first liquid from the inlet port to the sample chamber; and wherein the first liquid includes the test sample.

[0023] Another embodiment of the present invention is a sample holder for holding a test sample, the sample holder comprising: a body comprising float-zone silicon that is transmissive for radiation having a wavelength within the range of approximately 2.5 microns to 12.5 microns the body including: a first surface; a second surface that is substantially parallel with the first surface, wherein the first surface and second surface are separated by a first separation; and a sidewall that extends from the first surface to the second surface; wherein the first surface, the second surface, and the sidewall collectively define a sample chamber having (1) a sample region having a volume that is less than or equal to one microliter and (2) a capillary channel having a first width; and wherein the sidewall and second surface are separated by a second separation that changes monotonically from zero to the first separation along the first width; and an inlet port that is fluidically coupled with the sample region by the capillary channel; wherein the capillary channel is dimensioned and arranged to induce a capillary force operative for drawing a liquid from the inlet port into the sample region.

[0024] Yet another embodiment of the present invention is a method comprising: providing a sample holder for a test sample, the sample holder including a body comprising a first material that is transmissive for radiation having a wavelength within the range of approximately 2.5 microns to approximately 12.5 microns, and the sample holder having an inlet port and a sample chamber that includes a sample region and a capillary channel, wherein the capillary channel fluidically couples the inlet port and the sample region; and establishing physical contact between the inlet port and a liquid that contains the test sample; wherein physical contact between the inlet port and the liquid gives rise to a capillary force that draws the test sample into the sample chamber via the capillary channel.

### **Brief Description of the Drawings**

[0025] FIG. 1 depicts a schematic drawing of a sample holder in accordance with an illustrative embodiment of the present invention.

[0026] FIGS. 2A-D depict schematic drawings of perspective, top, side, and front views, respectively, of sample holder **100**.

[0027] FIG. 3A depicts a schematic illustration of sheath flow within a small-inner-diameter conduit.

[0028] FIG. 3B depicts a plot of viscosity as a function of inner diameter of a conduit for whole blood having different volume percentages of red blood cells.

[0029] FIG. 3C depicts a schematic drawing of an enlarged cross-section of a portion of sample chamber **210**.

[0030] FIG. 3D depicts a schematic drawing of a portion of sample holder **104** that includes open port **212** and inlet port **206-2**.

[0031] FIG. 4 depicts a plot of transmission for float-zone silicon and Czochralski-pulled silicon, at various thicknesses, over the range of wavelengths from 2 microns to 15 microns.

[0032] FIGS. 5A-B depict top views of substrates **220** and **222**, respectively, after the completion of etching to define their features.

[0033] FIG. 6 depicts a schematic drawing of a sample holder in accordance with a first alternative embodiment of the present invention.

[0034] FIG. 7 depicts a schematic drawing of a sample holder in accordance with a second alternative embodiment of the present invention.

[0035] FIG. 8 depicts a schematic drawing of a sample holder in accordance with a third alternative embodiment of the present invention.

[0036] FIG. 9A depicts a schematic drawing of a sample holder in accordance with a fourth alternative embodiment of the present invention.

[0037] FIG. 9B depicts a schematic drawing of microfluidic system **902**.

### **Detailed Description**

[0038] The following terms are defined for use in this Specification, including the appended claims:

- “**Mid-infrared radiation**” (MIR) is defined as electromagnetic radiation having a wavelength within the range of approximately 2.5 microns to approximately 12.5 microns.
- “**Transmissive**” is defined as having a transmission of at least 45%. For example, an element that is transmissive for mid-infrared radiation transmits at least 45% of any light signal having a wavelength within the range of approximately 2.5 microns to approximately 12.5 microns.

[0039] FIG. 1 depicts a schematic drawing of a sample holder in accordance with an illustrative embodiment of the present invention. Sample holder **100** is “microcuvette” operative for holding a minute volume of a liquid test sample. Sample holder **100** enables spectroscopic analysis of test sample **102** using mid-infrared radiation (*i.e.*, radiation **104**).

[0040] As discussed in U.S. Patent No. 8,344,323, which is incorporated herein by reference, the use of mid-infrared radiation (MIR) for optical chemical analysis is highly desirable because it is rich with spectral absorption lines for many important chemicals and compounds materials. Due to this rich spectral content, MIR is often referred to as the “fingerprint region” of the spectrum.

[0041] In the prior art, however, MIR is not normally used for chemical analysis in spectrometry-based systems because most host materials (*e.g.*, solvent fluids, blood, saline, bodily tissue, *etc.*) have a well-known absorption window in the mid-infrared wavelength range. Because of this absorption window, MIR does not significantly penetrate sample material in many applications, such as blood serum analysis, glucose monitoring, and the like.

[0042] Instead, prior-art spectroscopy systems are typically based on near-infrared light (*i.e.*, wavelengths within the range of approximately 800 nm to approximately 2500 nm). Unfortunately, the spectral information characteristic of target chemicals and compounds in the sample material is typically overwhelmed by the background spectral content associated with host material in which the sample material is contained (*e.g.*, water, which constitutes most of the material found in blood). In fact, the identification and

quantitative analysis of target analytes and chemicals is often precluded by the fact that their signature information is simply “lost in the noise” of spectral information of the host material.

[0043] In the illustrative embodiment, sample holder **100** includes window regions **106** and **108**, each which is transmissive for mid-infrared radiation (MIR). As a result, sample holder **100** enables radiation **104** to pass completely through the test sample to give rise to absorption signal **110** on the other side of the sample holder, where it can be detected and analyzed to determine the absorption characteristics of test sample **102** and identify its chemical composition. In some embodiments, the absorption spectra found in absorption signal **106** are compared against one or more chemical templates in a lookup table to facilitate the identification and quantification of specific chemicals and compounds.

[0044] In some embodiments, sample holder **100** includes only window region **106** and absorption signal **110** comprises light reflected by test sample **102**.

[0045] FIGS. 2A-D depict schematic drawings of perspective, top, side, and front views, respectively, of sample holder **100**. Sample holder **100** includes draw tube **202** and body **204**.

[0046] Draw tube **202** is a hypodermic needle, typically comprising stainless steel, which has an outer diameter of approximately 125 microns, an inner diameter of approximately 50 microns, and a length of approximately 2.5 millimeters. Inlet port **206-1** is defined by the open end of draw tube **202**, as indicated.

[0047] It should be noted that draw tube **202** can have any suitable outer diameter without departing from the scope of the present invention. It is an aspect of the present invention, however, that pain can be mitigated while extracting a bodily fluid (*e.g.*, blood) from a patient by using a draw tube having an outer diameter that is less than the minimum separation between pain receptors at the location on the patient from which fluid is drawn (*i.e.*, the draw site).

[0048] Nociceptive pain nerve receptors have a maximum density of 7-10 per mm (50-100 per mm<sup>2</sup>) – even in the most sensitive parts of the human body. This gives that the minimum separation between pain receptors is generally within the range of approximately 100 microns to approximately 140 microns. By limiting the outer diameter of draw tube to a diameter less than or equal to the minimum separation of pain receptors at the draw site, the present invention enables a technician, an untrained assistant, or the

patient themselves, to extract the fluid while causing little or no pain during the procedure. As a result, it is preferable that draw tube **202** have an outer diameter that is less than or equal to 140 microns. Conventional needles suitable for use in the present invention include, for example, ultra-thin, moshin-hair acupuncture needles, and the like. Note that this aspect of the invention is in contrast to conventional blood-drawing systems, which use approximately 250-micron diameter needles, as well as larger regular acupuncture needles, and conventional capillary blood lances, each of which can induce considerable pain. Draw tube **202**, however, causes little or no pain and minimal distress on the surface or within body during draw and transfer to the sample chamber. Further, withdrawal of draw tube **202** does not result in external seepage and leaves no discernable stress to the body.

[0049] Body **204** is a structural element that includes channel **208**, sample chamber **210**, and open port **212**.

[0050] Channel **208** is a conventional recess for locating draw tube **202**. Channel **208** has a depth suitable for insertion of the draw tube into body **204** after its fabrication. The length of channel **208** is sufficient to provide mechanical stability to the draw tube assembly. Channel **208** locates draw tube **202** such that it is fluidically coupled with capillary channel **216**.

[0051] Sample chamber **210** is a two-part cavity for containing test sample **102**. Sample chamber **210** includes sample region **214** and capillary channel **216**. By virtue of the use of MIR for optical analysis of test sample **102**, only a short interaction length with a test sample is required to develop a high-quality analysis of the sample. As a result, the thickness of the sample chamber can be extremely small (typically, a few tens of microns) and, as a result sample chamber **210** requires a total volume of only a few microliters ( $\mu\text{L}$ ). Typically the volume of sample chamber **210** is within the range of approximately 0.2  $\mu\text{L}$  to approximately 5  $\mu\text{L}$ . In the depicted example, the volume of sample chamber **210** is approximately one microliter. It should be noted, however, that as long as the thickness of sample region **214** is kept small enough to give rise to sufficient capillary force, sample chamber **210** can have virtually any practical volume without departing from the scope of the present invention.

[0052] Open port **212** is a conduit for fluidically coupling sample chamber **210** with the environment outside sample holder **100**. As a result, open port **212** enables egress of air from sample chamber **210** as fluid is drawn into sample holder **104**. In some

embodiments, draw tube **202** is not included and fluid is drawn into sample chamber **210** along inlet port **206-2**, which is located at an edge of open port **212**, while air is allowed to escape through the remainder of the open port.

[0053] It is another aspect of the present invention that sample holder **100** enables drawing of test sample **102** into sample chamber **210** without producing air bubbles in the liquid. The presence of bubbles in test sample **102** can interfere with its optical analysis. The development of air bubbles is especially detrimental for whole blood (or any other fluid) measurements in a photometric determination, for example. The presence of a large air bubble in the light path traversing the measurement zone results in overall measured blood values that are below the actual levels because a photometer interprets a bubble as a contributor to extremely low blood component concentrations. As a result, sample chamber **210** is dimensioned and arranged to mitigate the formation of bubbles fluid while being drawn.

[0054] Sample holder **100** is designed such that test sample **102** is loaded into sample chamber **210** via capillary force that is initiated by placing inlet port **206-1** into physical contact with liquid **218**. The dimensions of draw tube **202** and capillary channel **216** are selected such that liquid **218** retains a meniscus as it passes from draw tube **202** to capillary channel **214** to sample region **214**, as well as giving rise to a strong capillary force on the liquid such that it is rapidly drawn from inlet port **206-1** into sample chamber **210** without forming bubbles.

[0055] In some embodiments, the extremely small dimensions of draw tube **202** improves the ability of sample holder **100** to use capillary force to draw certain fluids, such as whole blood, by virtue of a significant decrease in its effective viscosity. This enables, among things, a significantly shorter bubble-free fill time for sample chamber **210**. Specifically, Using a draw tube having an inner diameter within the range of approximately 10 microns to approximately 50 microns leads to "sheath flow" for the fluid within the tube, which reduces the its effective viscosity, thereby giving rise to a high capillary force on the liquid and enabling a higher flow rate through the draw tube. For the purposes of this Specification, including the appended claims, "**sheath flow**" is defined as a flow of a component-containing fluid that is characterized by a substantially component-free layer next to the tube wall and a flow core that consists primarily of the components. For example, sheath flow of whole blood is characterized by a substantially blood-cell-free flow

region (primarily just plasma) near the tube wall that surrounds a flow core consisting mainly of blood cells.

[0056] FIG. 3A depicts a schematic illustration of sheath flow within a small-inner-diameter conduit. Arrangement **300** includes conduit **302**, through which whole blood flows.

[0057] Conduit **300** is analogous to draw tube **202** and has substantially the same dimensions (*i.e.*, an inner diameter of approximately 50 microns). As shown in the drawing, red blood cells are concentrated in the center portion of conduit **302** to form core **304**. Core is surrounded by outer layer **306**, which includes mainly only plasma. Pure plasma has a lower viscosity compared with the RBC core, as well as whole blood in a bulk-flow condition. As a result, the plasma serves as a lubrication layer that reduces the effective viscosity of the blood. Further, in some cases, without the development of outer layer **306**, suspended components, such as blood cells, could inhibit the retention of the meniscus at the forefront of liquid **218** as it is drawn into sample holder **100**. As a result, in such cases, it is only the development of sheath flow that makes it possible to successfully draw liquid **218** through tube **202** and capillary channel **216** and completely fill sample region **214** with test sample **102**.

[0058] FIG. 3B depicts a plot of viscosity as a function of inner diameter of a conduit for whole blood having different volume percentages of red blood cells. Plot **308** shows that, beginning at inner diameters of about 75 microns, the effective dynamic viscosity,  $\beta$ , of whole blood drops dramatically as the inner diameter shrinks.

[0059] Plot **308** evinces that whole blood in conduit **300** has an effective dynamic viscosity of approximately 1.5 mPa\*sec by virtue of its small circular cross-sectional area. As a result, the effective dynamic viscosity of whole blood in draw tube **202** is also 1.5 mPa\*sec.

[0060] In similar fashion, the dimensions of capillary channel **214** are selected so that it enables development of even higher capillary pressure and, in some cases, lower effective viscosity. The dimensions of sample region **214** are larger than those of capillary channel **216**, however, giving rise to a lower capillary pressure in this region, which mitigates bubble formation as liquid **218** fills the chamber.

[0061] Poiseuille's equation changes for a rectangular-section channel where instead of the 4<sup>th</sup> power of radius, the dimensions contribute the 3<sup>rd</sup> power of the smaller dimension

and first power of the larger dimension (for sample chamber **210**, these are 25 microns and 3 mm, respectively) for a flow rate of  $\sim 20$   $\mu\text{L}/\text{sec}$ . If sample chamber **210** were to be filled from a drop of blood introduced to the corner edge of the triangularly shaped capillary channel **216**, for example, it would be filled in approximately 0.012 seconds. The 20  $\mu\text{L}/\text{sec}$  flow rate represents a two orders of magnitude difference in throughput between draw tube **202** and sample chamber **210** at about the same driving capillary pressure. Essentially, the fluidic resistance of the draw tube is approximately one-hundred times higher than sample chamber **210**. Since they are connected in series, the two will behave in a way dominated by the fluidic resistance of draw tube **202**. The volume of the sample chamber is about 0.25  $\mu\text{L}$ , so with a 0.1  $\mu\text{L}/\text{sec}$  (capillary tube flow rate for effective blood viscosity) the sample chamber would be filled in about 2.5 seconds.

[0062] FIG. 3C depicts a schematic drawing of an enlarged cross-section of a portion of sample chamber **210**. FIG. 3C shows a cross-section taken through line a-a, as shown in FIG. 2B.

[0063] Sample region **214** is defined as the region of sample chamber **210** that is located between surfaces **310** and **312**, which are substantially parallel. Surfaces **310** and **312** are separated by distance, **t1**, which is substantially uniform through the region. In the depicted example **t1** is equal to 25 microns; however, any suitable value for **t1** is within the scope of the present invention.

[0064] Capillary channel **216** is defined as the edge region of sample chamber **210**, which is located between sidewall **314** and surface **312**. In the depicted example, sidewall **314** is a substantially planar surface that is oriented at angle,  $\theta$ , with respect to surface **312**, where  $\theta$  is approximately  $45^\circ$ . As a result, capillary channel **216** is a triangularly shaped region having width, **w1**, of 25 microns. The thickness, **t2**, of capillary channel **216** is smaller than **t1** and changes linearly from zero to **t1** across the width, **w1**, of the capillary channel. In some embodiments, sidewall **314** is has a shape other than planar, such as curved. In such embodiments, however, thickness **t2** still increases monotonically from zero to **t1** across width **w1**.

[0065] By virtue of its smaller dimensions, the capillary force generated in capillary channel **216** is higher than that generated in sample region **214**. Capillary channel **216** extends around the entire inner periphery of sample chamber **210** and is open to the atmosphere around sample holder **100** at open port **212**, as described below.

[0066] The amount of capillary force available for drawing liquid **218** into sample chamber **210** to form test sample **102** can be determined by assuming maximal wetting at inlet port **206-1**. This gives that the inner radius of draw tube **202** is the same as the radius of the meniscus of the liquid. Using Poiseuille's law for capillary pressure, in a tube having a circular cross-section with 0.05 mm internal diameter, the capillary pressure developed is 600 mm. Since draw tube **202** is fluidically coupled with triangularly shaped capillary channel **216**, there is ample capillary pressure to feed the entire inner periphery of sample chamber **210**, in both directions, to fill the entire chamber with liquid **218**.

[0067] Throughput is linear with respect to the dynamic viscosity, however, so the result above should be scaled by a factor equal to the ratio of the viscosities of water and whole blood. The typical bulk dynamic viscosity of whole blood at 37 °C is 3 to 4 times that of water at 20 °C - specifically 3-4 mPa\*sec, which would give the time required to fill sample chamber **210** with whole blood as 0.2 second.

[0068] Liquid **218** is drawn into sample chamber **210** until the chamber is completely full and the meniscus of the liquid reaches open port **212**. Open port **212** is characterized by a significantly lower magnitude of capillary force imparted on liquid **218** due to the fact that it is characterized by a separation between its top and bottom surfaces that is too large to develop significant capillary force. As a result, once liquid **218** reaches the open port, the capillary force on liquid **212** drops off and the draw of the liquid into sample chamber **210** stops automatically.

[0069] FIG. 3D depicts a schematic drawing of a portion of sample holder **104** that includes open port **212** and inlet port **206-2**. FIG. 3D shows a cross-section of the sample holder taken through line b-b, as shown in FIG. 2B.

[0070] As seen in the figure, inlet port **206-2** includes capillary channel **216** and channel **316**, which collectively enable drawing of liquid **218** into sample chamber **210** via capillary force.

[0071] Channel **316** has the same thickness, **t1**, as sample region **214**, as described above. The width, **w2**, of channel **316** is selected to facilitate the development of sufficient capillary force to enable the filling of the sample chamber. Typically **w2** is within the range of a few microns to a few hundred microns.

[0072] Channel **316** terminates at open port **212**, which has a thickness **t3**. The value of thickness **t3** is selected to be large enough to give rise to a capillary force that is

too weak to draw liquid into sample chamber **210**. In the depicted example, thickness **t3** is approximately 100 microns; however, one skilled in the art will recognize, after reading this Specification, that **t3** can have any suitable practical value.

[0073] Returning now to FIGS. 2A-D, body **204** comprises substrates **220** and **222**, each of which comprises a material that is transmissive for MIR. In some embodiments, only one of the substrates is transmissive for MIR. Each of substrates **220** and **222** includes recessed features that collectively define channel **208**, sample chamber **210**, and open port **212**.

[0074] Unfortunately, the material palette available in the prior art for use in window regions **106** and **108** is extremely limited due to typically poor transmittance across the 2.5 micron to 12.5 micron wavelength range. As a result, exotic materials, such as work-hardened silver halide and zinc selenide, have typically been used as structural materials in such components, as disclosed in U.S. Patent No. 8,541,743, which is incorporated herein by reference.

[0075] It is yet another aspect of the present invention that the use of undoped FSZ provides significant advantages over the prior art. Specifically, and in contrast to generally held opinion, float-zone silicon, having a thickness of 500 microns or less, is transmissive out to far infrared wavelengths.

[0076] FIG. 4 depicts a plot of transmission for float-zone silicon and Czochralski-pulled silicon, at various thicknesses, over the range of wavelengths from 2 microns to 15 microns.

[0077] Plot **400** shows that the transmission through FZS, for thicknesses of 0.38 and 0.5 mm, remains above 45% over the mid-infrared range. The high transmission for FZS arises from the fact that, during the float zone refining process, substantially all impurities are eliminated, including substitutional dopants such as boron, phosphorus, arsenic, antimony and metallic impurities, and light impurities of oxygen and any carbon, by being pushed ahead of the melt region and reincorporated into the mono-crystalline ingot at much lower concentrations.

[0078] For Czochralski-pulled Silicon (OCz-Si), however, large absorption bands are seen at approximately 9-micron wavelength for each tested thickness (*i.e.*, 0.5 mm, 1 mm, and 5 mm). The absorption band is due to oxygen impurities in the material. It should be

noted that there is also a smaller absorption band at approximately 5.8 microns, which are due to the presence of other dopants in the material.

[0079] For operation in the MIR, it is critical that window regions **106** and **108** do not substantially absorb light signal **104**. FSZ is both transmissive for MIR, readily available, and easy to handle and process. Although other MIR-transmissive materials, such as Silver Halides and Zinc Selenide, can be used in embodiments of the present invention, these materials are exotic and expensive, and they are difficult to handle and incorporate into a body **204**. As a result, FSZ is preferably used for window regions **106** and **108**.

[0080] Because of the ease of etching FSZ, body **204** can be fabricated using conventional planar processing techniques. In the depicted example, body **204** is fabricated in three steps.

[0081] First, substrate **220** is etched to a depth of 25 microns (*i.e.*, depth **t1**) in sample region **214** and the region of channel **208**. One skilled in the art will recognize that, with the use of the proper etching technology, this operation also forms sidewall **216**. In some embodiments, sidewall **216** is formed or further shaped in a subsequent etch or grinding operation.

[0082] Second, substrate **222** is etched to a depth of approximately 100 microns in the regions of channel **208** and open port **212**. This depth is selected to provide a total height of channel **208** of 125 microns once substrates **220** and **222** are joined to complete body **204**, as discussed below.

[0083] It should be noted that, while embodiments of the present invention provide particular advantage to systems for interrogating a test sample with mid-infrared radiation, aspects of the present invention afford advantages in systems that interrogate test samples with radiation of other wavelengths, such as visible light, x-ray radiation, *etc.* As a result, in some embodiments, one or both of window regions **106** and **108** comprise a material that is transmissive for other wavelengths, such as glass, plastic, quartz, composite materials, and the like. In some embodiments, one or both of window regions **106** and **108** is an element formed separately from body **204** and then affixed to the body.

[0084] FIGS. 5A-B depict top views of substrates **220** and **222**, respectively, after the completion of etching to define their features.

[0085] Substrate **220** is fabricated in two etch steps. First, nascent sample chamber **504** and nascent port region **506** are etched to a depth of **t1** from the original surface of the substrate (*i.e.*, surface **502**). The formation of nascent sample chamber **504** and nascent port region **506** exposes surface **310**, which defines the top surface of sample region **214**, as described above.

[0086] A second etch is then used to define nascent channel region **508** and nascent scribe line **510**. Typically, these features are etched to a depth that is substantially equal to the outer diameter of draw tube **202**. As a result, in the depicted example, these features are etched to a depth of approximately 63 microns.

[0087] In similar fashion, substrate **222** is etched to a depth of approximately half the outer diameter of draw tube **202** (*i.e.*, 63 microns) from its original top surface (*i.e.*, surface **312**) to define nascent channel region **512**, nascent open port region **514**, and nascent scribe line **516**.

[0088] Once the fabrication of each of substrates **220** and **222** is complete, one of the substrates is flipped over to mate surfaces **312** and **502**, which are permanently joined using a conventional joining method, such as oxygen-assisted plasma bonding, thermos-anodic bonding, fusion bonding, an adhesive layer, and the like. This completes channel **208**, sample chamber **210**, and open port **212**. The individual die are then singulated and draw tube **202** is inserted into channel **208** and affixed to complete sample holder **100**. Because each of nascent channels **508** and **512** have a depth of approximately half the outer diameter of draw tube **202**, the center of the draw tube is substantially aligned with the center of sidewall **314**.

[0089] Once fully formed individual bodies **204** are singulated from the multi-die substrates. To facilitate die singulation, in the depicted example, nascent scribe line **510** is formed around the perimeter of the region of body **204** on substrate **220**.

[0090] One skilled in the art will recognize that FIGS. 5A-B depict individual die of a plurality of sample holder die formed simultaneously on each substrate. Typically, integrated-circuit die are singulated from a processed wafer by sawing through the wafer between the die. This would create significant particulate issues for embodiments of the present invention, however, and is preferably avoided. The addition of scribe lines **510** and **516** on substrates **220** and **222**, respectively, enable singulation of the individual die by

concentrating fracture strain in the regions of the scribe lines. As a result, the individual die can be singulated without minimal particulate generation.

[0091] In some embodiments, a heater is included within sample chamber **210** to enable evaporation of the background solvent of test sample **102** through open port **212** while inlet port **206-1** is in contact with liquid **218**. Such embodiments enable an increase in the concentration of constituent solutes in the test sample by inducing additional capillary inflow as the solvent is removed.

[0092] FIG. 6 depicts a schematic drawing of a sample holder in accordance with a first alternative embodiment of the present invention. Sample holder **600** is analogous to sample holder **100**; however, sample holder **600** includes optical element **602**, which is disposed on window region **106** to enable an optical function to be performed on radiation **104**.

[0093] Optical element **602** is a refractive lens for collimating radiation **104**. In some embodiments, optical element **602** is another optical element, such as a microlens array, a diffraction grating, a holographic element, a Fresnel zone plate, a Bragg grating, a prism, and the like. In some embodiments, an optical element is disposed on each of window regions **106** and **108**.

[0094] FIG. 7 depicts a schematic drawing of a sample holder in accordance with a second alternative embodiment of the present invention. Sample holder **700** is analogous to sample holder **100**; however, sample holder **700** includes regions **702-1** and **702-2**, each of which includes a dry reagent that can mix and chemically react with test sample **102** to produce an optical effect, such as a color change, that is observable through window region **106**. In some embodiments, one or more of regions **702** is located within a micro channel that isolates its reaction from other regions of sample chamber **210**. As a result, multiple, simultaneous independent observations are enabled.

[0095] In some embodiments, accurate measurement of ion concentration in test sample **102** is desired. Such analysis is critical in many clinical settings, such as neonatal care. In the prior art, such ion measurement is performed via a complex and expensive method, such as atomic absorption or flame emission spectroscopy. The present invention enables low-cost, simple electrochemical methods for measuring ion concentrations within sample region **102**.

[0096] FIG. 8 depicts a schematic drawing of a sample holder in accordance with a third alternative embodiment of the present invention. Sample holder **800** is analogous to sample holder **100**; however, sample holder **800** includes electrodes **802-1** and **802-2**, which are electrically independent of one another, as well as draw tube **202**.

[0097] In some embodiments, the resistance between electrodes **802-1** and **802-2** is monitored and used as an indicator of the ionic content of test sample **102**.

[0098] The inclusion of electrodes **802-1** and **802-2** also enables the use of Faraday's principle to "electro-plate" different ions electrochemically onto each of electrodes **802-1** and **802-2**. One skilled in the art will recognize that different ions require different electrochemical potentials to plate. As a result, by biasing each of electrodes **802-1** and **802-2** with a different voltage relative to, for example, draw tube **202**, each electrode selectively plates a different ion, independent determination of the concentration for each ion is enabled. In some embodiments, sample holder **800** includes a different number of electrodes **802**.

[0099] Electroplating to completion is difficult and very time-consuming using large volumes of solution. Since the volume of test sample **102** is so small, however, such electrolytic analysis can be performed rapidly.

[00100] System **800** enables measurement of the blood chemical parameters of, for example, sodium (132-140 mg/dl), potassium (3.5-6 mg/dl), calcium (8-10 mg/dl) and pH (7.3-7.45). Further, pure salts can be evaluated in system **800** one at a time and through a range of spiked concentrations. Then all salts will be evaluated by sensor simultaneously.

[00101] In some embodiments, electronic circuitry instead of, or in addition to, electrodes **802**, such as integrated circuit devices, are included in body **204**. As a result, sample holder **800** can include capabilities such as wireless communication, signal amplification and pre-processing, signal processing, sample analysis, and the like. Further, in some embodiments, the electronic circuitry can enable remote powering of such circuitry via inductive power coupling.

[00102] In some embodiments, a microfluidic device or system is included in sample chamber **210** to enable manipulation of different portions of test sample **102**.

[00103] FIG. 9A depicts a schematic drawing of a sample holder in accordance with a fourth alternative embodiment of the present invention. Sample holder **900** is analogous to sample holder **100**; however, sample holder **900** includes a plurality of sample regions **214-1** through **214-3**, and microfluidic system **902**. In the depicted example, microfluidic system **902** is a cross-flow filtration system that physically segregates constituents of whole blood and provides a different test sample within each of sample regions **214**. As a result, each test sample can be individually characterized using, for example, mid-infrared spectroscopy.

[00104] FIG. 9B depicts a schematic drawing of microfluidic system **902**. Microfluidic system **902** includes inlet port **904**, channels **906-1** through **906-3**, filters **908** and **910**, and outlet ports **912-1** through **912-3**. Microfluidic system **902** enables embodiments of the present invention to segregate cells by size, which can be used to monitor concentrations of abnormal blood cells, *etc.*

[00105] System **902** exploits the fact that red blood cells (RBCs) and white blood cells (WBCs) are significantly different sizes. RBCs are typically 6-8 micron diameter donut-shaped structures with thickness of 2-2.5 microns and a minimum thickness at their center of 0.8-1 micron. WBCs are more spherically shaped with a have a diameter distribution of approximately 10-20 microns for about 85% of the cells and approximately 7-8 microns for about 15% of the cells.

[00106] Filter **908** is located in the sidewall between channels **906-1** and **906-2**. Filter **908** is characterized by filter pores of approximately 5 microns distributed uniformly along the filter. As blood flows across its surface, WBCs are blocked from passing through filter **908** due to their size. As a result, WBCs remain in channel **906-1** and flow to outlet port **912-1**. Outlet port **912-1** is fluidically coupled with sample region **214-1**. As a result, sample region **214-1** is loaded with a test sample rich in white blood cells. RBCs and plasma readily pass through filter **908** into channel **906-2**.

[00107] Filter **910** is located in the sidewall between channels **906-2** and **906-3**. Filter **910** is characterized by filter pores of approximately 1.5 microns, which are distributed uniformly along the filter. As RBCs and plasma flows through channel **906-2** and across the surface of filter **910**, RBCs are blocked from passing through filter **910** due to their size. As a result, RBCs remain in channel **906-2** and flow to outlet port **912-2**. Outlet port **912-2** is fluidically coupled with sample region **214-2**. As a result, sample

region **214-2** is loaded with a test sample rich in red blood cells. It should be noted that, while sickle-cell diseased red blood cells have an altered donut shape, these cells still have thicknesses of 2-2.5 microns and are also prevented from passing through filter **910**.

[00108] Plasma passes through filter **910** into channel **906-3** to be carried to outlet port **912-3** to load sample region **214-3** with a test sample that is substantially pure plasma.

[00109] In some embodiments, microfluidic system **902** includes microfluidic devices other than filters, such as mixers, heaters, separation elements, and the like. It will be clear to one skilled in the art, after reading this Specification, how to make and use alternative embodiments of the present invention wherein microfluidic system **902** includes any practical microfluidic device, or a portion of a larger microfluidic system.

[00110] It is to be understood that the disclosure teaches just some examples of embodiments in accordance with the present invention and that many variations of the invention can easily be devised by those skilled in the art after reading this disclosure and that the scope of the present invention is to be determined by the following claims.

What is claimed is:

- 1.** A sample holder for holding a test sample, the sample holder comprising:  
an inlet port; and  
a sample chamber that includes a first window region that is transmissive for a first radiation that is characterized by a wavelength within the range of approximately 2.5 microns to approximately 12.5 microns, the sample chamber having a sample region and a capillary channel that fluidically couples the inlet port and the sample region;  
wherein the sample region is characterized by a first capillary force for a first liquid and the capillary channel is characterized by a second capillary force for the first liquid, and wherein the second capillary force is higher than the first capillary force such that the capillary channel is operative for drawing the first liquid from the inlet port to the sample chamber; and  
wherein the first liquid includes the test sample.
- 2.** The sample holder of claim 1 further comprising a body that includes:  
the first window region, the first window region having a first surface;  
a second window region comprising a second window region being transmissive for the first radiation, the second surface being substantially parallel with the first surface; and  
a sidewall that extends from the first surface to the second surface;  
wherein the first surface and second surface collectively define the sample region, and wherein the sample region has a first thickness; and  
wherein the first surface, the second surface, and the sidewall collectively define the capillary channel such that the capillary channel has a first width and a second thickness that changes monotonically from zero to the first thickness along the first width.
- 3.** The sample holder of claim 2 wherein the sidewall forms an angle that is equal to or less than 45° with one of the first surface and second surface.
- 4.** The sample holder of claim 2 wherein the body further comprises an optical element.
- 5.** The sample holder of claim 2 wherein the body further comprises a microfluidic system, the microfluidic system being located within the sample chamber.
- 6.** The sample holder of claim 2 wherein the body further comprises a reagent, the reagent being located within the sample chamber.

**7.** The sample holder of claim 1 wherein the first window region comprises float-zone silicon.

**8.** The sample holder of claim 1 further comprising a draw tube that includes the inlet port, the draw tube having an outer diameter that is less than the minimum spacing of pain receptors at a draw site.

**9.** The sample holder of claim 1 wherein the inlet port is dimensioned and arranged to enable sheath flow of the sample from the inlet port to the sample chamber.

---

**10.** A sample holder for holding a test sample, the sample holder comprising:  
a body comprising:  
a first surface;  
a second surface that is substantially parallel with the first surface, wherein the first surface and second surface are separated by a first separation; and  
a sidewall that extends from the first surface to the second surface;  
wherein the first surface, the second surface, and the sidewall collectively define a sample chamber and a capillary channel having a first width; and  
wherein the sidewall and second surface are separated by a second separation that changes monotonically from zero to the first separation along the first width; and  
an inlet port that is fluidically coupled with the sample region by the capillary channel;  
wherein the capillary channel is dimensioned and arranged to induce a capillary force operative for drawing a liquid from the inlet port into the sample region.

**11.** The sample holder of claim 10 wherein the body comprises float-zone silicon that is transmissive for mid-infrared radiation.

**12.** The sample holder of claim 10 further comprising a draw tube that includes the inlet port, the draw tube having an outer diameter that is less than or equal to 140 microns, wherein the draw tube fluidically couples the inlet port and the capillary channel.

**13.** The sample holder of claim 12 wherein the draw tube is dimensioned and arranged to enable sheath flow of the sample.

**14.** The sample holder of claim 10 wherein the body includes the inlet port.

**15.** The sample holder of claim 14 wherein the inlet port is dimensioned and arranged to enable sheath flow of the sample from the inlet port to the sample chamber.

**16.** The sample holder of claim 10 further comprising a microfluidic system that at least partially resides within the sample chamber.

**17.** The sample holder of claim 10 further comprising an optical element that is disposed on a third surface of the body that is optically coupled with the sample chamber.

**18.** The sample holder of claim 10 further comprising an electrode that is located within the sample chamber.

**19.** The sample holder of claim 10 further comprising a first region comprising a first reagent, the first region being located within the sample chamber.

**20.** The sample holder of claim 19 further comprising a second region comprising a second reagent, the second region being located within the sample chamber.

---

**21.** A method comprising:

providing a sample holder for a test sample, the sample holder including a body comprising a first window region that is transmissive for mid-infrared radiation, and the sample holder having an inlet port and a sample chamber that includes a sample region and a capillary channel, wherein the capillary channel fluidically couples the inlet port and the sample region; and

establishing physical contact between the inlet port and a liquid that contains the test sample;

wherein physical contact between the inlet port and the liquid gives rise to a capillary force that draws the test sample into the sample chamber via the capillary channel.

**22.** The method of claim 21 wherein the sample holder is provided by operations comprising:

forming a first cavity in a first substrate comprising the first window region, the first cavity including a sidewall and a first surface that is substantially planar; and

joining the first substrate and a second substrate that includes a second window region having a second surface, wherein the first surface, second surface, and sidewall collectively define the sample chamber such that the sample region is characterized by a first capillary force for the first liquid and the capillary channel is characterized by a second

capillary force for the first liquid, and wherein the second capillary force is higher than the first capillary force.

**23.** The method of claim 21 wherein the first window region comprises float-zone silicon.

**24.** The method of claim 21 wherein the sample holder is provided such that it further includes a draw tube that comprises the inlet port and a second port that is fluidically coupled with sample region via the capillary channel, and wherein the draw tube has an outer diameter that is less than the minimum separation of pain receptors at a draw site.

**25.** The method of claim 24 wherein the outer diameter is less than or equal to 140 microns.

**26.** The method of claim 21 further comprising increasing the concentration of an analyte within the sample region by evaporating a solvent, the test sample including the solvent and the analyte.

**27.** The method of claim 21 further comprising reacting a reagent with the test sample in a first region that is within the sample chamber.

**28.** The method of claim 21 wherein the sample holder is provided such that it further includes an optical element.

**29.** The method of claim 21 wherein the sample holder is provided such that the sample chamber includes at least a portion of a microfluidic system.

**30.** The method of claim 21 further comprising:  
providing a first electrode that is located within the sample chamber; and  
providing an electric field having a first magnitude between the first electrode and a second electrode, wherein the electric field traverses at least a portion of the test sample;  
wherein the magnitude of the electric field is based on the electrochemical potential required to electroplate a first analyte.

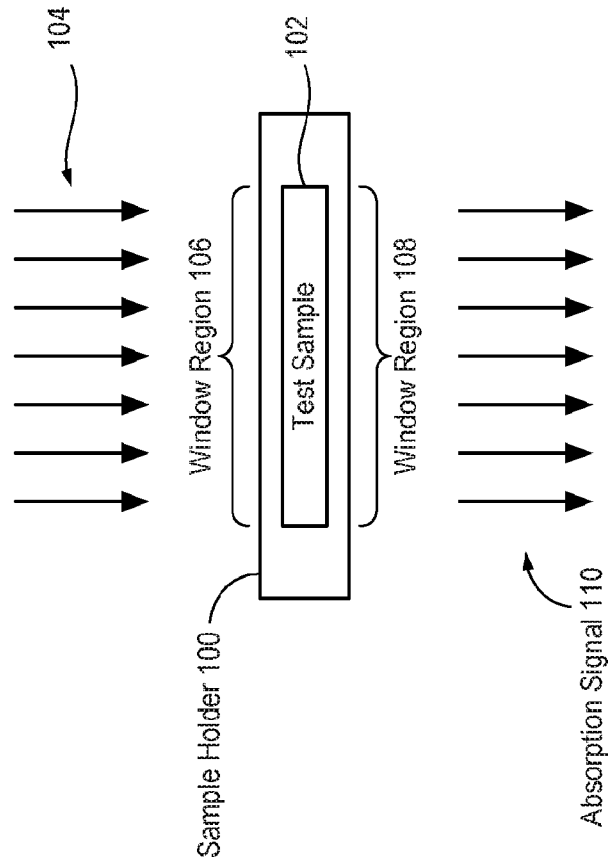
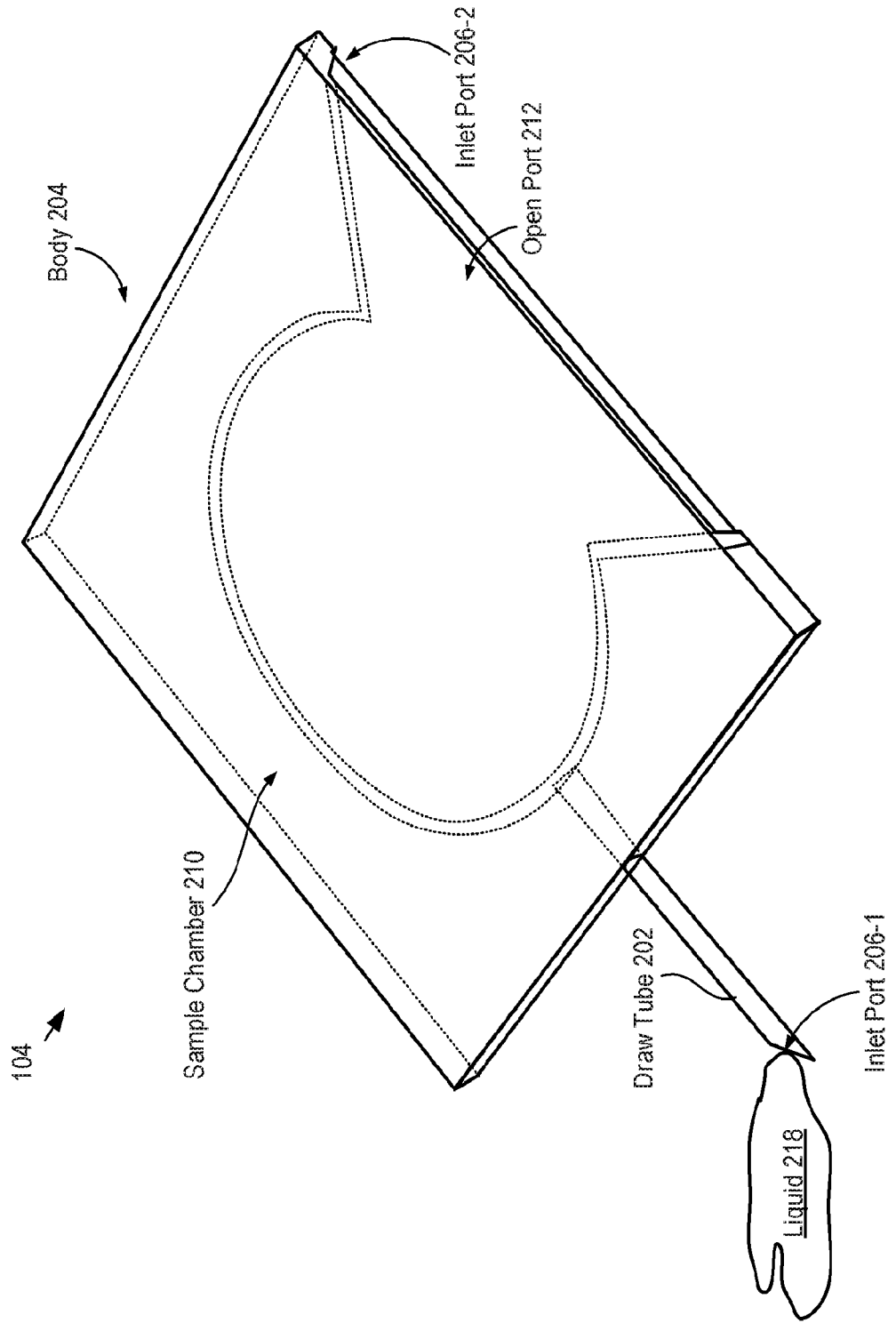
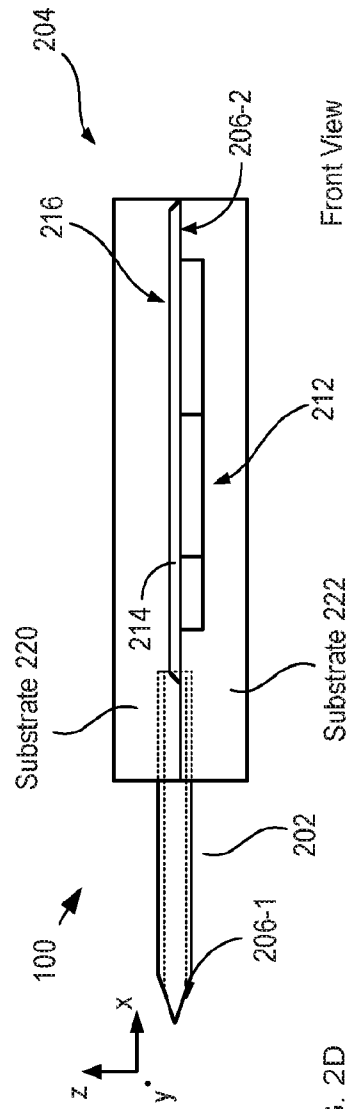
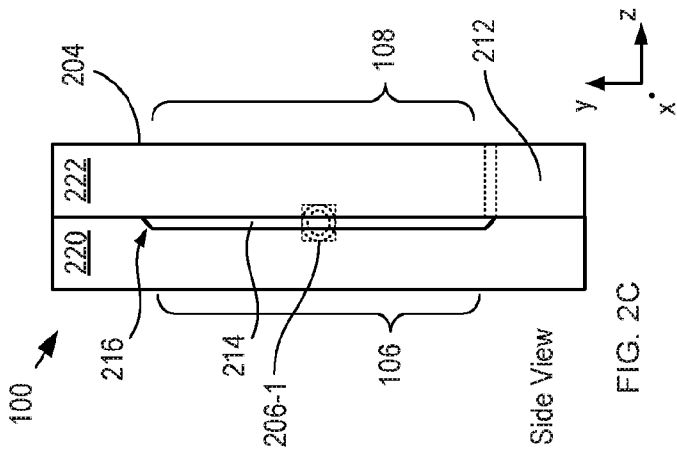
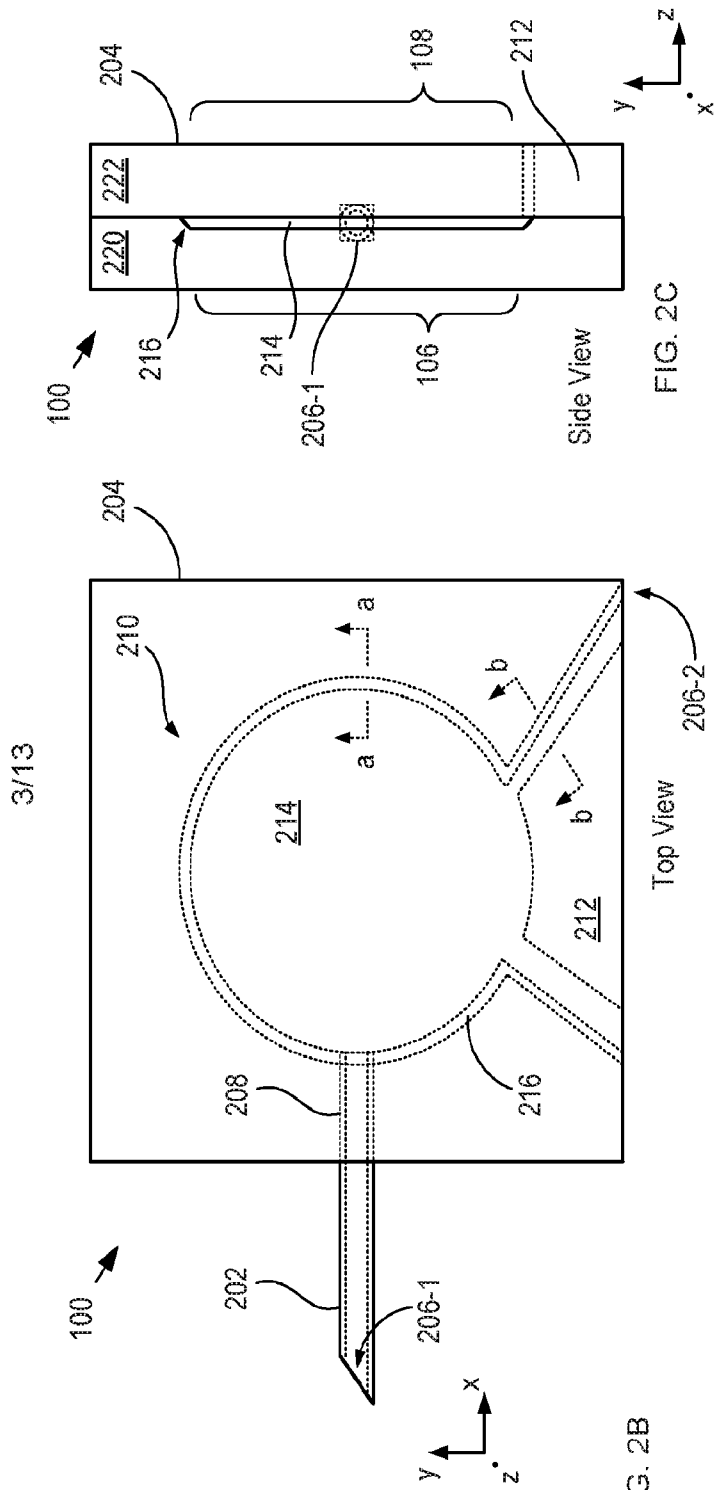

FIG. 1

FIG. 2A

2/13





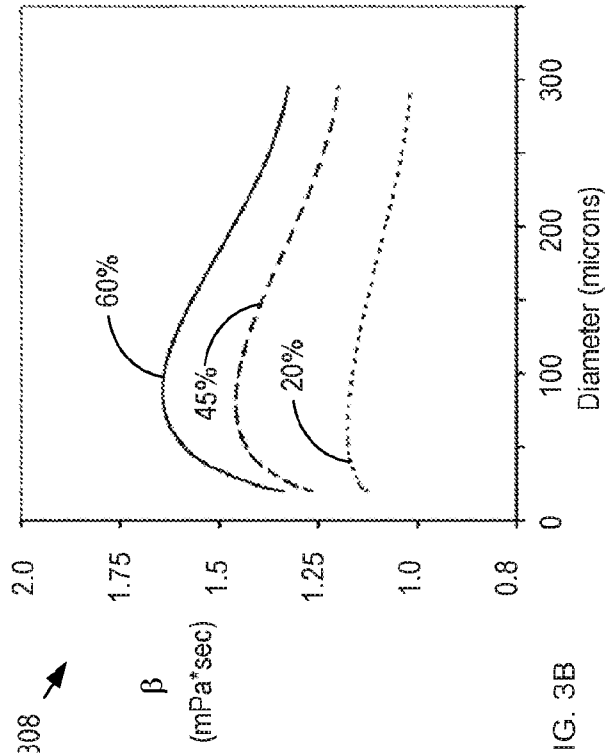
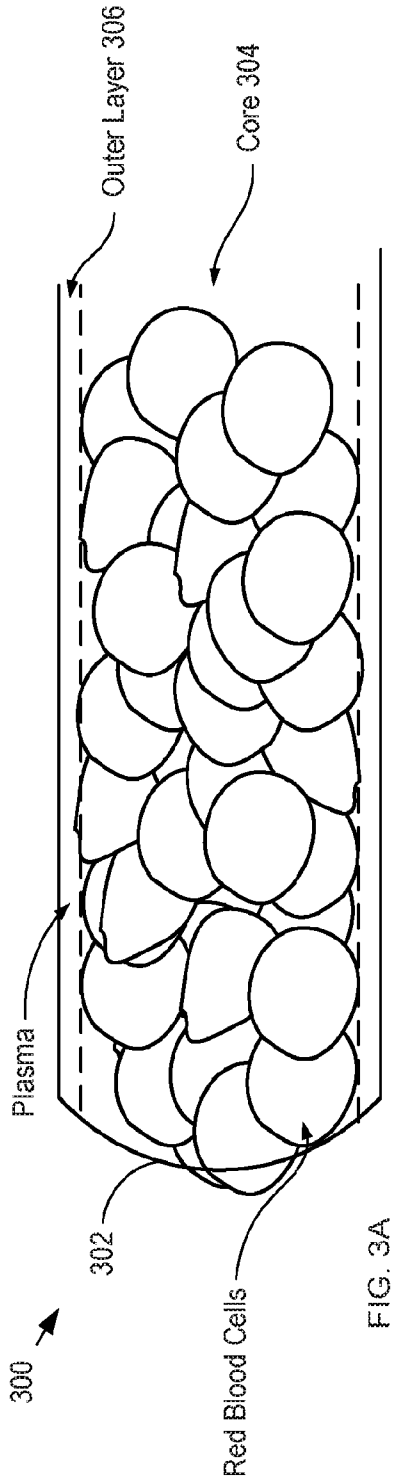
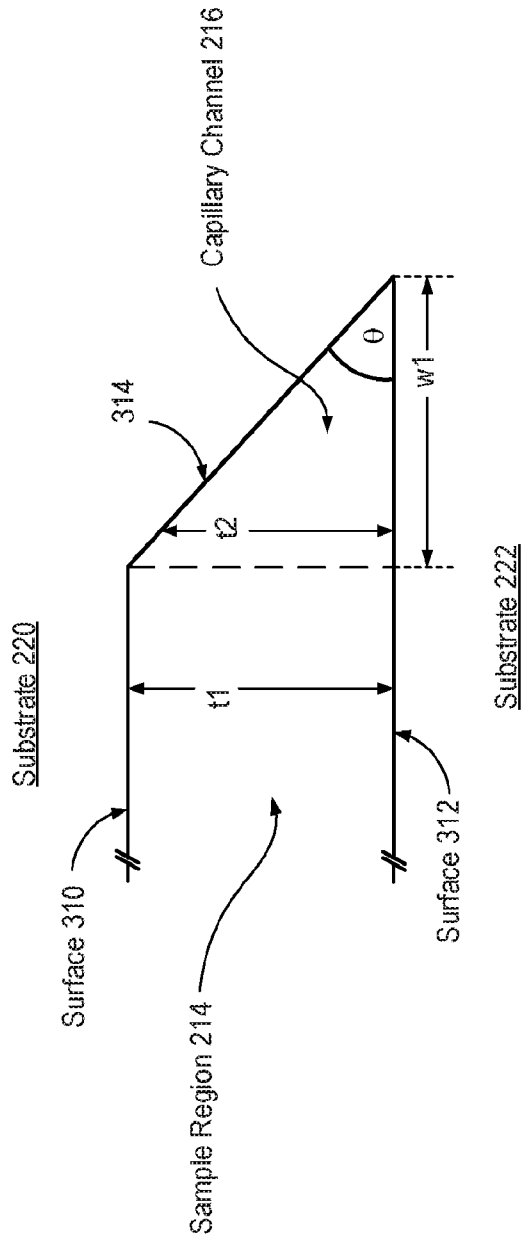

FIG. 3C

5/13

210 →



cross-section through a-a

FIG. 3D

6/13

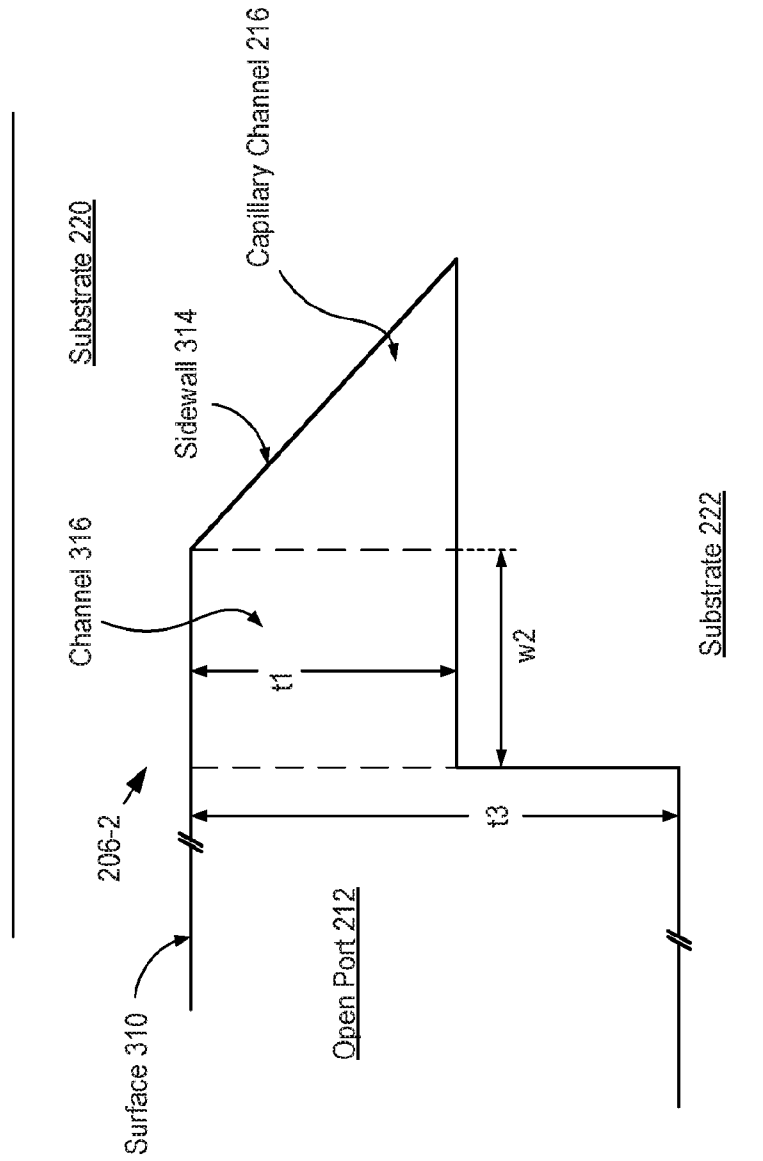

cross-section through b-b

7/13

FIG. 4

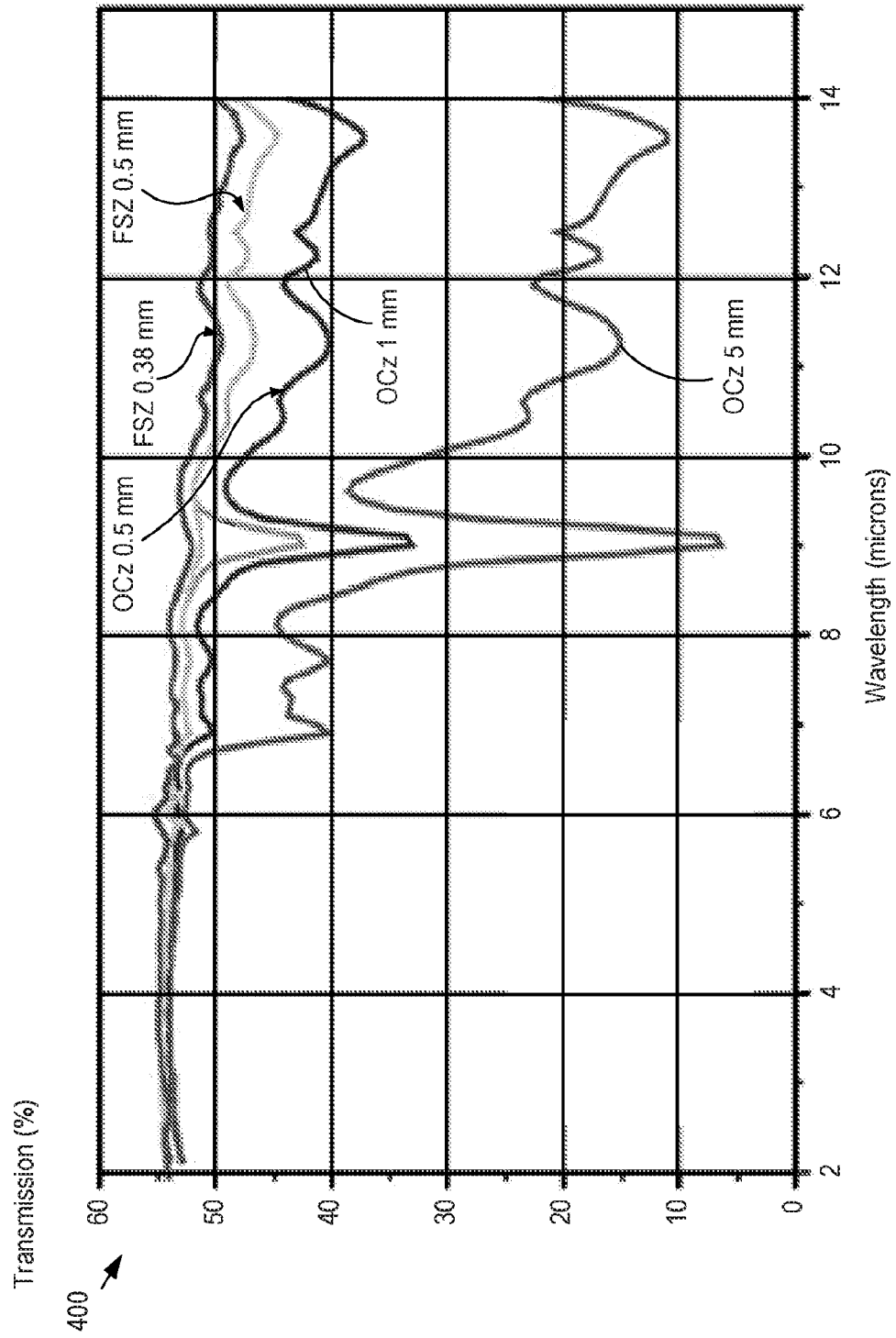

8/13

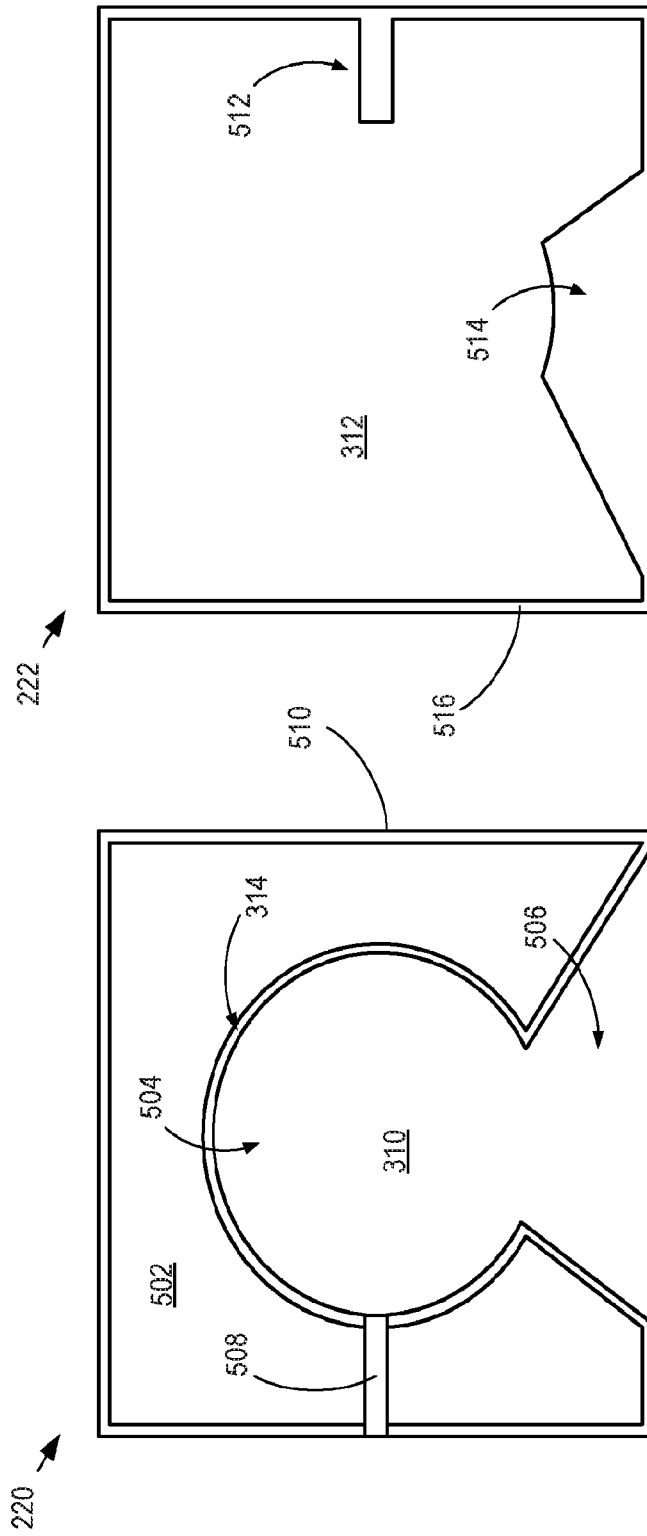

FIG. 5B

FIG. 5A

9/13

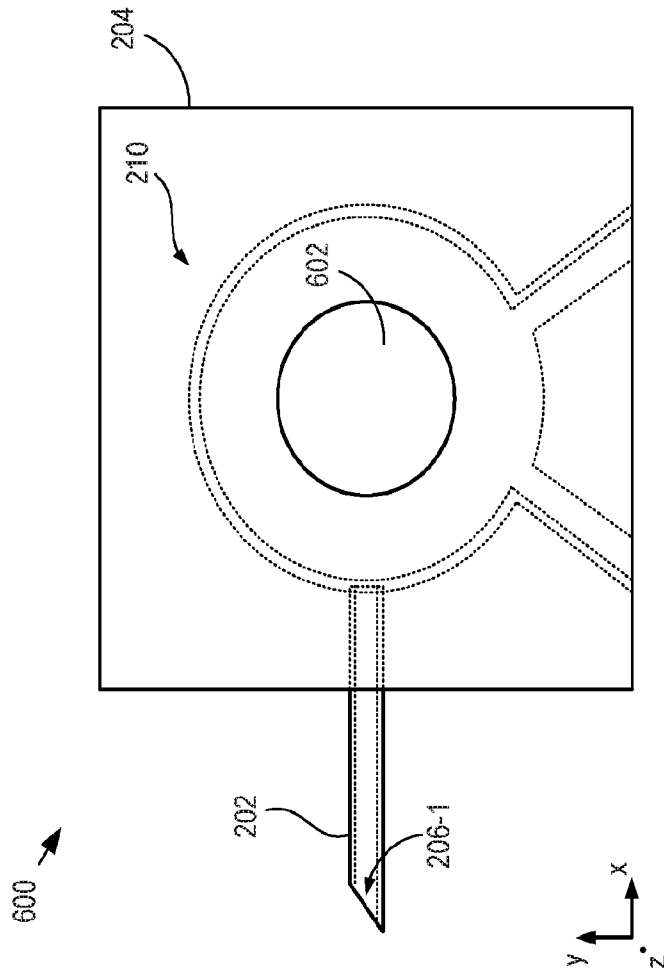

FIG. 6

10/13

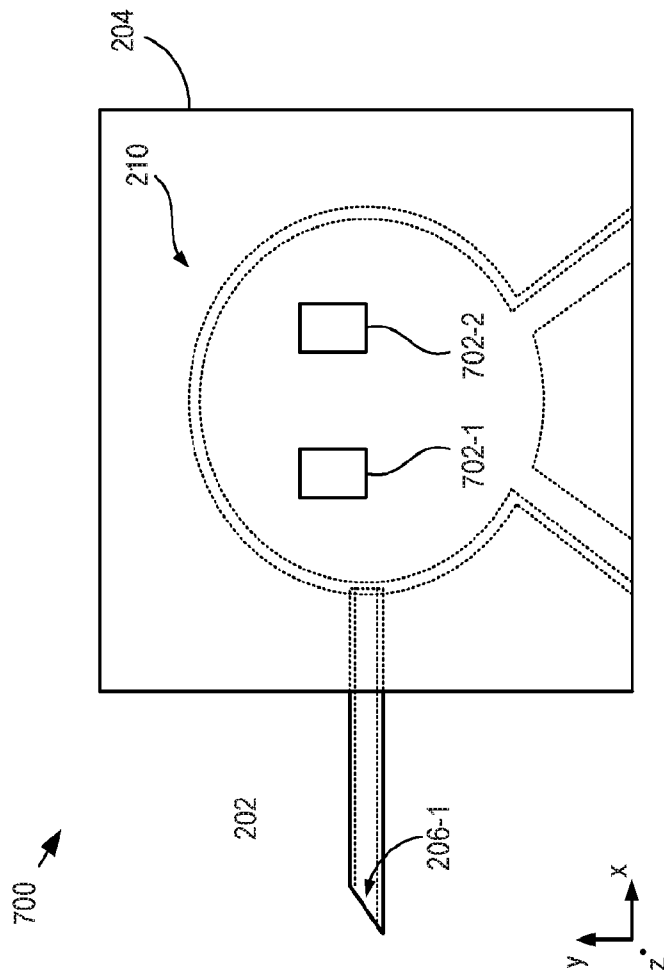

FIG. 7

11/13

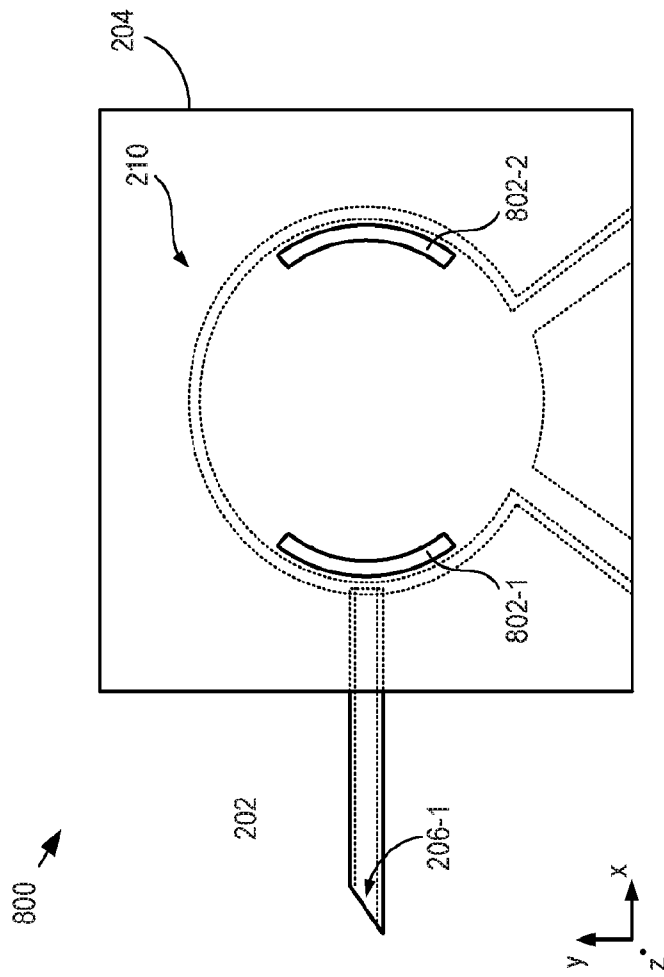

FIG. 8

12/13

FIG. 9A

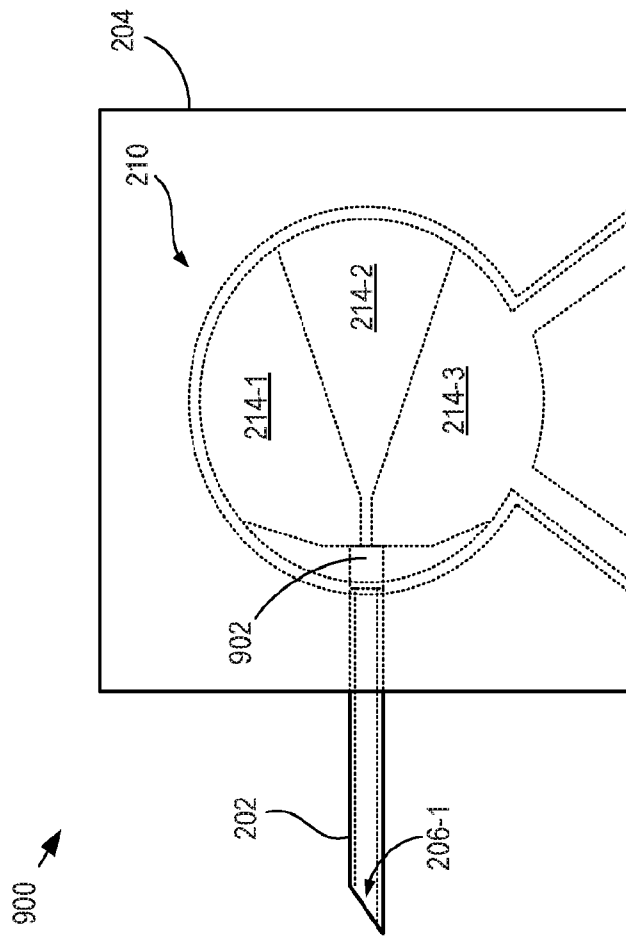
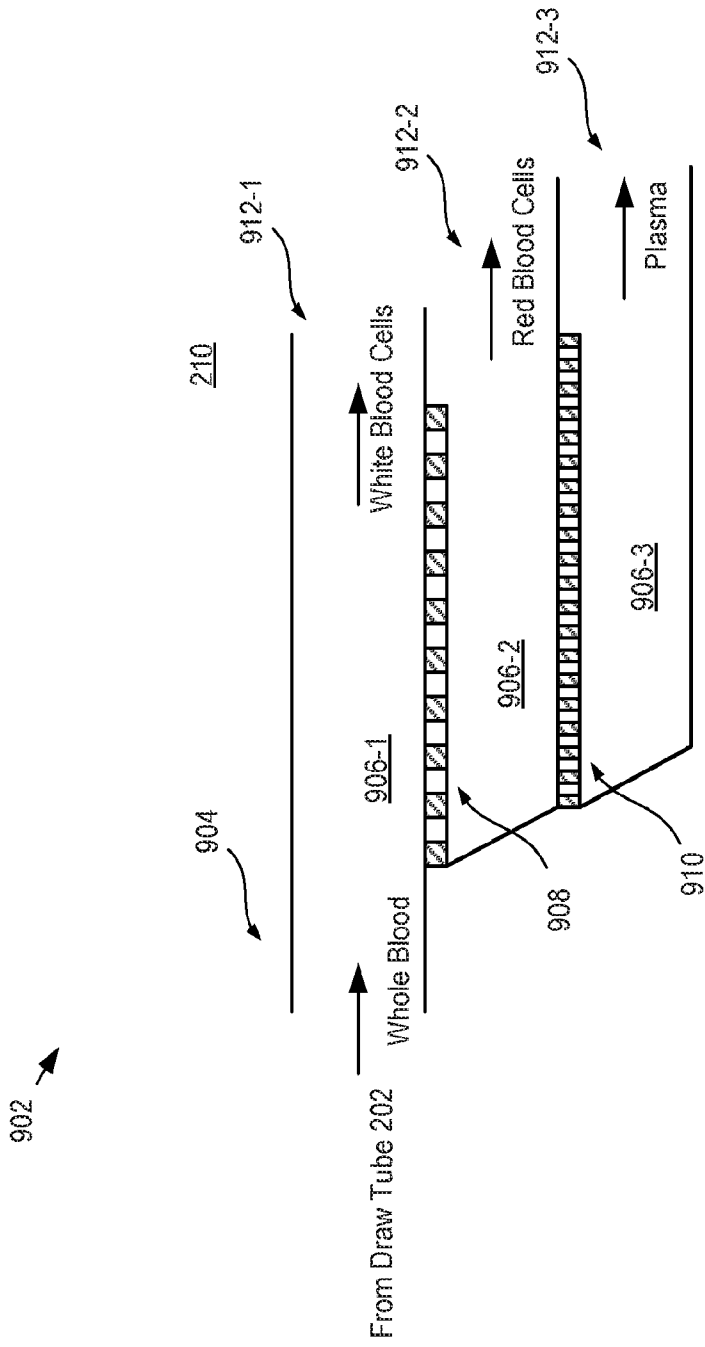

FIG. 9B

13/13



## INTERNATIONAL SEARCH REPORT

International application No.

PCT/US 16/13481

## A. CLASSIFICATION OF SUBJECT MATTER

IPC(8) - A61B 5/157 (2016.01)

CPC - A61B 5/157

According to International Patent Classification (IPC) or to both national classification and IPC

## B. FIELDS SEARCHED

Minimum documentation searched (classification system followed by classification symbols)

IPC(8) : A61B 5/157 (2016.01)

CPC : A61B 5/157

Documentation searched other than minimum documentation to the extent that such documents are included in the fields searched

IPC(8) : A61B 5/00, 5/15, 5/151; G01N 1/00, 1/02, 1/10, 21/00, 21/01, 21/11 (2016.01)

CPC : A61B 5/00, 5/15, 5/151, 5/150343; G01N 1/00, 1/02, 1/10, 21/00, 21/01, 21/11

Electronic data base consulted during the international search (name of data base and, where practicable, search terms used)

Patbase, Google Patent, Google Scholar: microcuvette, cuvette, liquid, fluid, blood, sample, collect, window, IR, MIR, infrared, capillary, greater, larger, increase, first, second, force, angle, angular, chamfer, fillet, side, needle, cannula, draw tube, sheath flow, floatzone, sillirnn

## C. DOCUMENTS CONSIDERED TO BE RELEVANT

Category*	Citation of document, with indication, where appropriate, of the relevant passages	Relevant to claim No.
X --- Y	US 5,674,457 A (WILLIAMSSON et al) 7 October 1997 (07.10.1997) see especially col 2, ln 27 to col 3, ln 14, col 3, ln 23-34, fig 1-3	1-4, 6, 9, 21-22, 26-28 ----- 5, 7-8, 23-25, 29-30
Y	US 2012/0122084 A1 (WAGNER et al) 17 May 2012 (17.05.2012) see especially para [0093], [0102], [0106], [0198]	5, 7, 23, 29
Y	US 5,801,057 A (SMART et al) 1 September 1998 (01.09.1998) see especially col 3, ln 4-6, col 4, ln 36-46, col 5, ln 7-16, fig 1, 2A	8, 24, 25
Y	US 2010/0032298 A1 (REEL et al) 11 February 2010 (11.02.2010) see especially para [0004], [0005], [0008], [0056]	30
A	US 2014/0219886 A1 (CHOI et al) 7 August 2014 (07.08.2014) see whole document	1-9, 21-30

 Further documents are listed in the continuation of Box C. 

\* Special categories of cited documents:

"A" document defining the general state of the art which is not considered to be of particular relevance

"E" earlier application or patent but published on or after the international filing date

"L" document which may throw doubts on priority claim(s) or which is cited to establish the publication date of another citation or other special reason (as specified)

"O" document referring to an oral disclosure, use, exhibition or other means

"P" document published prior to the international filing date but later than the priority date claimed

"T" later document published after the international filing date or priority date and not in conflict with the application but cited to understand the principle or theory underlying the invention

"X" document of particular relevance; the claimed invention cannot be considered novel or cannot be considered to involve an inventive step when the document is taken alone

"Y" document of particular relevance; the claimed invention cannot be considered to involve an inventive step when the document is combined with one or more other such documents, such combination being obvious to a person skilled in the art

"&amp;" document member of the same patent family

Date of the actual completion of the international search

26 April 2016 (26.04.2016)

Date of mailing of the international search report

11 MAY 2016

Name and mailing address of the ISA/US

Mail Stop PCT, Attn: ISA/US, Commissioner for Patents  
P.O. Box 1450, Alexandria, Virginia 22313-1450

Facsimile No. 571-273-8300

Authorized officer:

Lee W. Young

PCT Helpdesk: 571-272-4300  
PCT OSP: 571-272-7774

## INTERNATIONAL SEARCH REPORT

International application No.

PCT/US 16/13481

**Box No. II Observations where certain claims were found unsearchable (Continuation of item 2 of first sheet)**

This international search report has not been established in respect of certain claims under Article 17(2)(a) for the following reasons:

1.  Claims Nos.:  
because they relate to subject matter not required to be searched by this Authority, namely:
  
2.  Claims Nos.:  
because they relate to parts of the international application that do not comply with the prescribed requirements to such an extent that no meaningful international search can be carried out, specifically:
  
3.  Claims Nos.:  
because they are dependent claims and are not drafted in accordance with the second and third sentences of Rule 6.4(a).

**Box No. III Observations where unity of invention is lacking (Continuation of item 3 of first sheet)**

This International Searching Authority found multiple inventions in this international application, as follows:  
This application contains the following inventions or groups of inventions which are not so linked as to form a single general inventive concept under PCT Rule 13.1.

Group I: claims 1-9, 21-30 directed to a sample holder having a window  
Group II: claims 10-20 directed to a changing sidewall separation

The groups of inventions above do not relate to a single general inventive concept under PCT Rule 13.1 because, under PCT Rule 13.2, they lack the same or corresponding special technical features for the following reasons:

--- see continuation sheet ---

1.  As all required additional search fees were timely paid by the applicant, this international search report covers all searchable claims.
2.  As all searchable claims could be searched without effort justifying additional fees, this Authority did not invite payment of additional fees.
3.  As only some of the required additional search fees were timely paid by the applicant, this international search report covers only those claims for which fees were paid, specifically claims Nos.:
4.  No required additional search fees were timely paid by the applicant. Consequently, this international search report is restricted to the invention first mentioned in the claims; it is covered by claims Nos.:  
1-9, 21-30

- Remark on Protest**
- The additional search fees were accompanied by the applicant's protest and, where applicable, the payment of a protest fee.
- The additional search fees were accompanied by the applicant's protest but the applicable protest fee was not paid within the time limit specified in the invitation.
- No protest accompanied the payment of additional search fees.

INTERNATIONAL SEARCH REPORT

International application No.

PCT/US 16/13481

Box III Observations where unity of invention is lacking (Continuation of item 3 of first sheet)

Special Technical Features:

The special technical feature of the Group I claims is a window transmissive for mid infrared light, which is not present in the claims of Group II.

The special technical feature of the Group II claims is a side wall separated from a surface by a distance that changes monotonically from zero, which is not present in the claims of Group I.

Common Technical Features

Groups I-II share the technical feature of a sample holder having an inlet and a capillary channel that draws a sample into a sample chamber or region. This generic feature does not avoid the prior art, as evinced by US 2014/0219886 A1 to Choi et al (hereinafter Choi) which teaches a sample holder having an inlet and a capillary channel that draws a sample into a sample region (para [0029]-[0038], fig 1-3, inlet capillary 220 draws sample to detection zone 210).

Therefore, the listed inventions lack unity of invention under PCT Rule 13 because they do not share a same or corresponding special technical feature.