

(19) (KR)
(12) (B1)

(51) 。 Int. Cl. ⁷ (45) 2002 09 12
F03D 11/00 (11) 10 - 0351719
(24) 2002 08 24

(21) 10 - 1999 - 0058841 (65) 2000 - 0012683
(22) 1999 12 17 (43) 2000 03 06

(73) 1가 23 - 201

(72) 5 - 22 203

:

(54)

(16,17) (4,5,6,7) (10), ()
(20) (14,15) 가 (, ,)
(12), (13)

, 가, . , , , , .

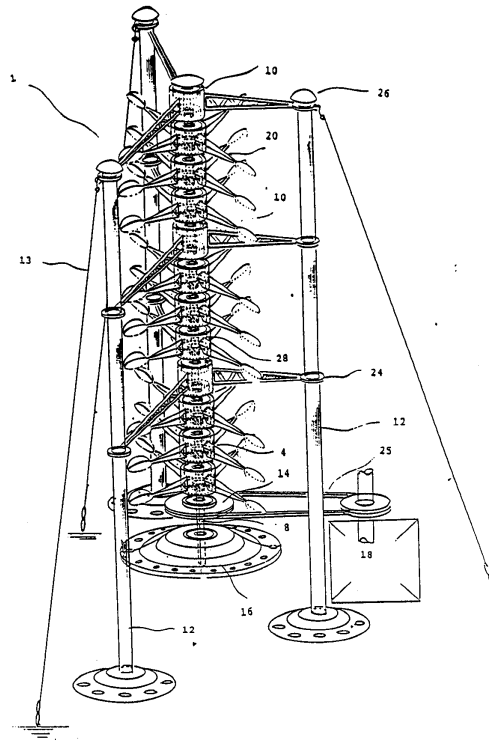

1

2

3

4

5

6

1.2.3

4.

5.

가

6.

가

가

A - A

7. 가 8.

8,8a,8b.

9. 10.

11. 12.

13. 14.

15.

17. 18.

19. 20.

21. 22.

23. 24.

25. 26.

27. 7a. 22a. 4a. 20a. 20b. 21a. 21b.

가

,

, ,

(12)

(13)

가

가

가

, 가, , 가

(20) (12) (13)

(20) (10) (12)

(17,18)

(4,5,6,7) 가

1 (21) 4 (8) (21b)

(21a)가 (21a) (8) (21b)

가 (16) (8)

(19) 6 (16) (8)

(22) (8) 가 (19) (22a)

(8) (4)가 (4a) 1 4 (22a) (8)

(4a) (21a) (4a) (8) (21a)가

m/m) (4) (4) ((, (3m/m - 10)가

4 가 (4a) 가

(19) (20a) (20a) (4a) (20b)가

(19) (4) (8)

(, (4)) (10)가 (8) (4)

(4) (4) (4) (10) (10) (10)

(8) (10) (22a) (21a)가 (22a) (22) (10) (23)

(24)가 (24) (13)

(12) (12) (16) (4)

(13) (14) (14) (14)

(4) (25) (14) (16)

(18)가 (14), (4) 가 (16)

(8), (4) 가

2 (9) (17) (9) , 가
 (7)가 (19)
 (7) , (9) 가
 (15) (17)
 ▢ (15), , ▢ (17)
 (7), (15) (7a)가 (9)
 (18) (9) (25)
 (15) (22a) (9) (7,7a),
 (22) (9)

3 (8a)(8b) 3 ,
 (16) (8a)(8b) 가 ,
 (8a) (8a) 3
 21b)가 (5)가 (21a) (5)
 (8a) (8a) (6)가 (22a) (22) (5) 3
 (21a) (21a)가 (6) 3
 (22a) (8a) (22) (22) (8a)
 (5) (21a) (8a) (14),
) (16)
 (5), (6), (5), (6)...
 (14), (6), (5).... 1
 (8a) (21a)가 (5) 2 (8b) (22)
 (5) 가 (25) (8b) 1 (8a)
 (22) (6) 2 (8b) (21a)가 (6)가
 (25) (5),(6)

가 , (16) 1 (8a) (21b) (21a)
 (5) (14) 2 (8b) (22a) (22)
 (5) 가 (16) 2 (8b)
 (21b) (21a) (6) (14) 1
 (8a) (22a) (22) (6) 가
 1, 2 (14) (25)

4 (19) (21) (22) (8,9)

5 (4,5,6,7) 가 (7) A - A

6 (16,17), (14) , 가 (15)

(16,17) 가
 (, ,)
 (13)
 ,)

(19)

(4,5,6,7), 가 (14,15) 가
 , 가 (12),
 , (가, ,
 ,

가 .

(57)

1.

1. ;

;

, 가

;

;

,

, 가

2.

2. ;

;

,

가

;

가

;

, , ,

가

.

3.

3. ;

가 ;

, , ;

;

,

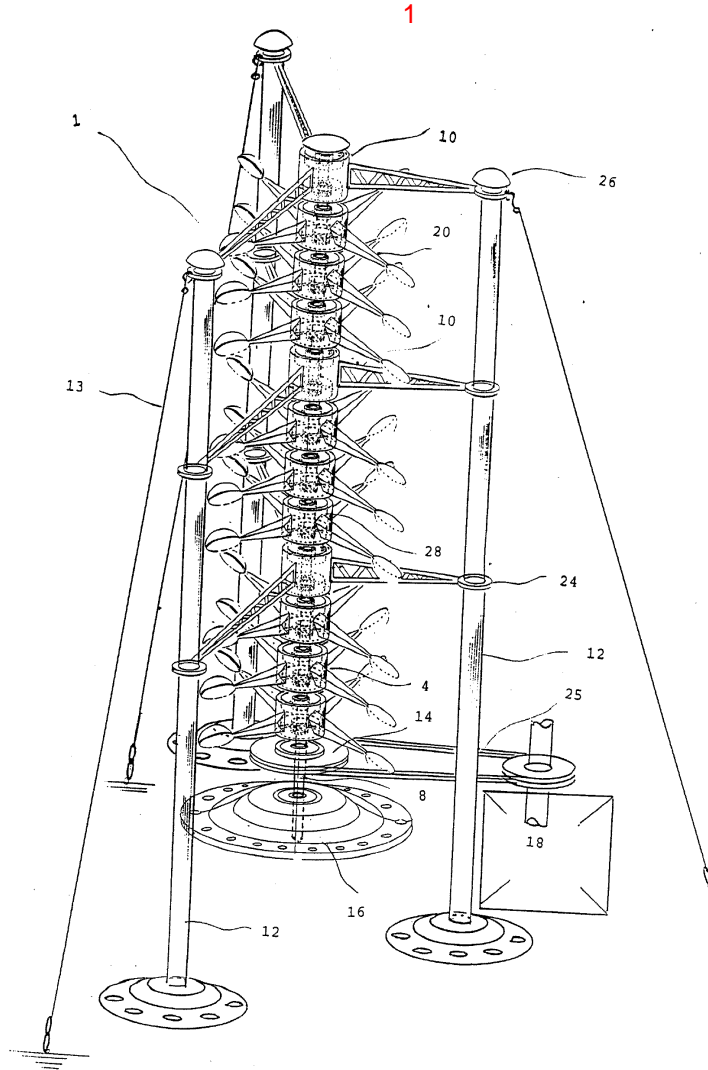

2

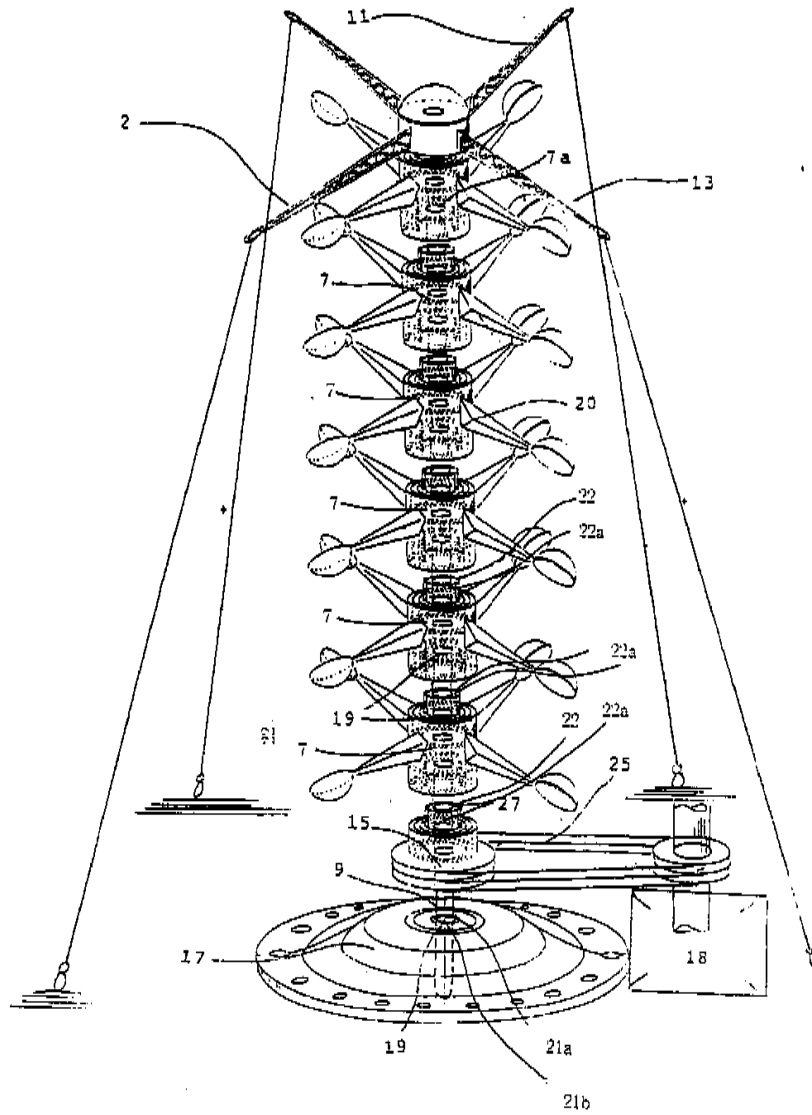

3

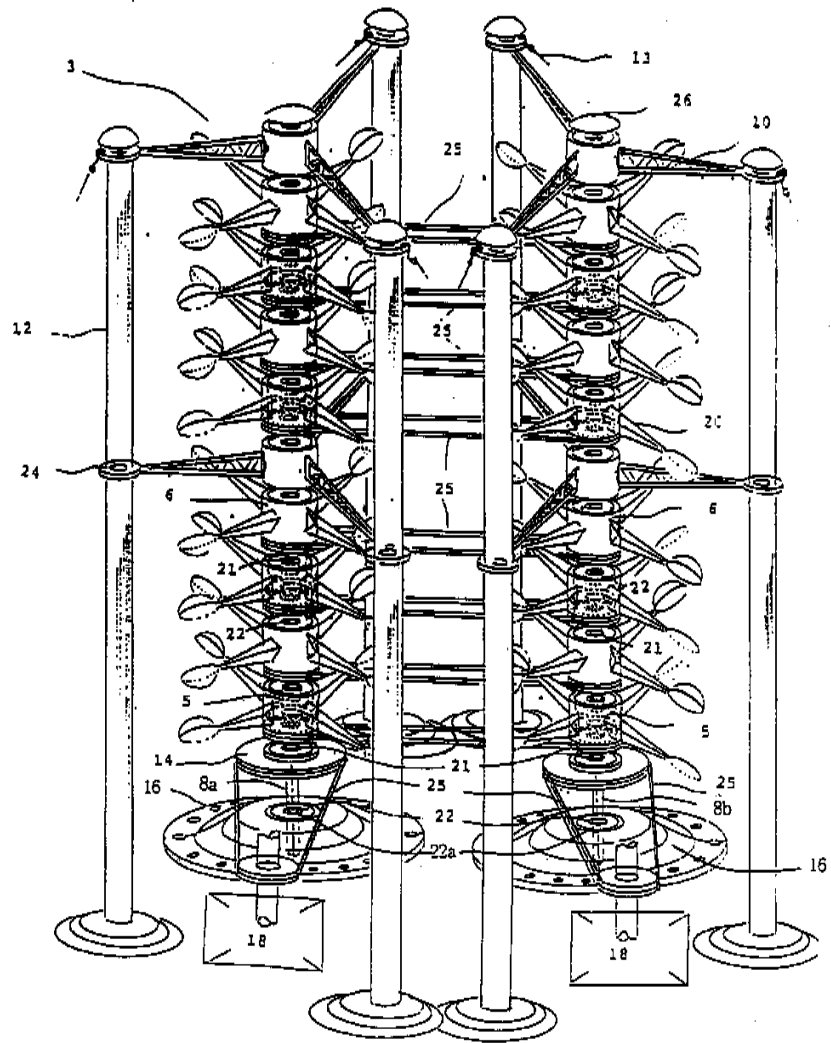

4

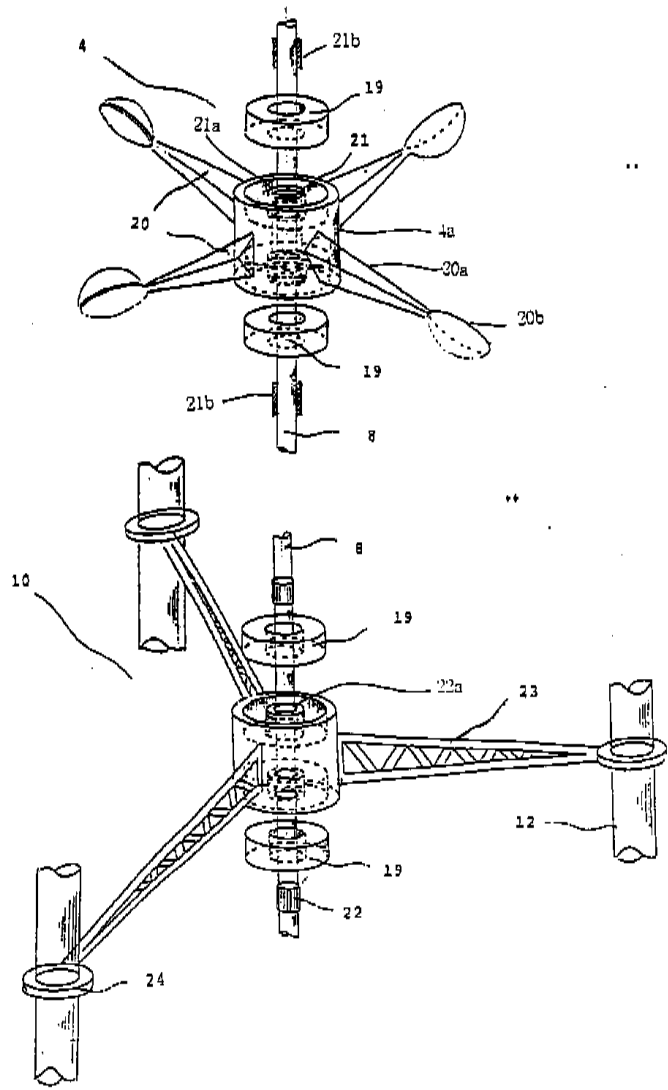

5

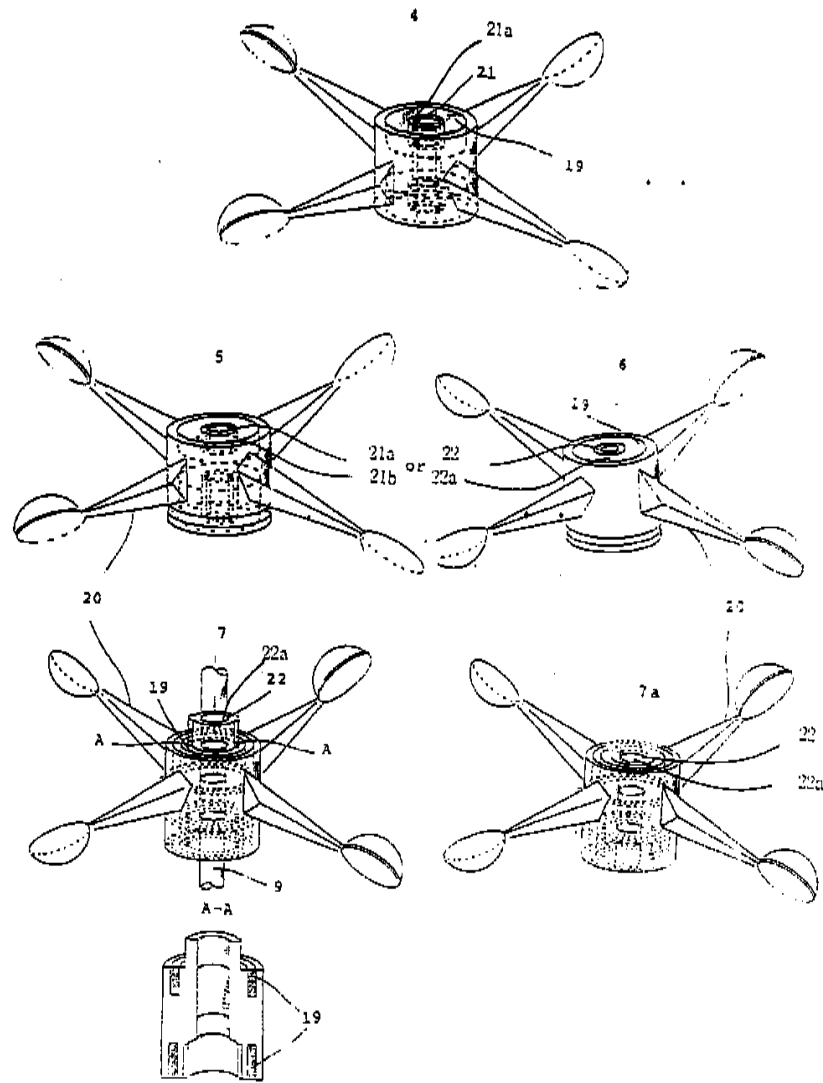

6

