

(12) STANDARD PATENT
(19) AUSTRALIAN PATENT OFFICE

(11) Application No. **AU 2016343893 B2**

(54) Title
Implant devices with a pre-set pulley system

(51) International Patent Classification(s)
A61B 17/11 (2006.01) **A61B 17/06** (2006.01)

(21) Application No: **2016343893** (22) Date of Filing: **2016.08.31**

(87) WIPO No: **WO17/074554**

(30) Priority Data

(31) Number	(32) Date	(33) Country
62/247,938	2015.10.29	US

(43) Publication Date: **2017.05.04**

(44) Accepted Journal Date: **2021.08.19**

(71) Applicant(s)
AxoGen Corporation

(72) Inventor(s)
Deister, Curt

(74) Agent / Attorney
IP Gateway Patent and Trade Mark Attorneys Pty Ltd, PO Box 1321, SPRINGWOOD, QLD, 4127, AU

(56) Related Art
US 20130123810 A1
US 20150173739 A1
US 20140379009 A1
US 20050038471 A1



- (51) International Patent Classification:
A61B 17/11 (2006.01) A61B 17/06 (2006.01)
- (21) International Application Number:
PCT/US2016/049660
- (22) International Filing Date:
31 August 2016 (31.08.2016)
- (25) Filing Language: English
- (26) Publication Language: English
- (30) Priority Data:
62/247,938 29 October 2015 (29.10.2015) US
- (71) Applicant: AXOGEN CORPORATION [US/US]; 13631 Progress Boulevard, Suite 400, Alachua, FL 32615 (US).
- (72) Inventor: DEISTER, Curt; c/o Axogen Corporation, 13631 Progress Boulevard, Suite 400, Alachua, FL 32615 (US).
- (74) Agents: SALIWANCHIK, David, R. et al.; Saliwanchik, Lloyd & Eisenschenk, PO Box 142950, Gainesville, FL 32614-2950 (US).

- (81) Designated States (unless otherwise indicated, for every kind of national protection available): AE, AG, AL, AM, AO, AT, AU, AZ, BA, BB, BG, BH, BN, BR, BW, BY, BZ, CA, CH, CL, CN, CO, CR, CU, CZ, DE, DK, DM, DO, DZ, EC, EE, EG, ES, FI, GB, GD, GE, GH, GM, GT, HN, HR, HU, ID, IL, IN, IR, IS, JP, KE, KG, KN, KP, KR, KZ, LA, LC, LK, LR, LS, LU, LY, MA, MD, ME, MG, MK, MN, MW, MX, MY, MZ, NA, NG, NI, NO, NZ, OM, PA, PE, PG, PH, PL, PT, QA, RO, RS, RU, RW, SA, SC, SD, SE, SG, SK, SL, SM, ST, SV, SY, TH, TJ, TM, TN, TR, TT, TZ, UA, UG, US, UZ, VC, VN, ZA, ZM, ZW.
- (84) Designated States (unless otherwise indicated, for every kind of regional protection available): ARIPO (BW, GH, GM, KE, LR, LS, MW, MZ, NA, RW, SD, SL, ST, SZ, TZ, UG, ZM, ZW), Eurasian (AM, AZ, BY, KG, KZ, RU, TJ, TM), European (AL, AT, BE, BG, CH, CY, CZ, DE, DK, EE, ES, FI, FR, GB, GR, HR, HU, IE, IS, IT, LT, LU, LV, MC, MK, MT, NL, NO, PL, PT, RO, RS, SE, SI, SK, SM, TR), OAPI (BF, BJ, CF, CG, CI, CM, GA, GN, GQ, GW, KM, ML, MR, NE, SN, TD, TG).

Published:
— with international search report (Art. 21(3))



WO 2017/074554 A1

(54) Title: IMPLANT DEVICES WITH A PRE-SET PULLEY SYSTEM

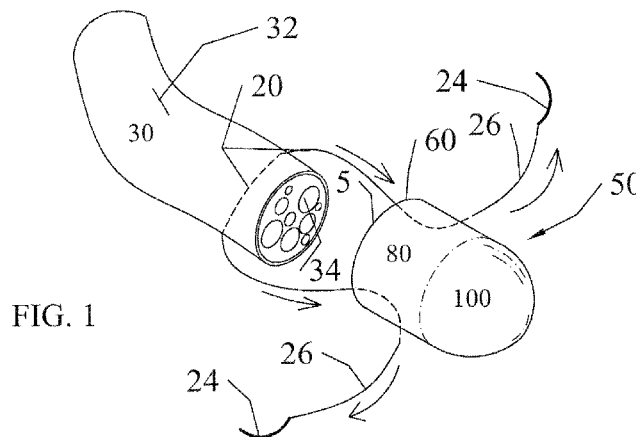

FIG. 1

(57) Abstract: The problem of positioning one or more nerve ends inside a sheathing implant is solved by the use of a pulley and cinching systems that pull a nerve end into an implant and that can adjust the diameter of an implant to conform the implant to the diameter of the nerve, respectively. The pulley system utilizes a suture that traverses the wall of an implant leaving one end outside the implant wall and another end that can be attached to a nerve. Pulling the suture end outside the wall pulls the nerve attached to the other end of the suture into the bore of the implant. A cinching system utilizes specially arranged sutures within the wall of an implant to tighten or cinch up the wall after a nerve is placed therein, so as to conform at least part of the implant to the diameter of the nerve. Methods are also disclosed by which such pulley systems can be formed during an intraoperative procedure.

2016343893 18 May 2021

DESCRIPTION

IMPLANT DEVICES WITH A PRE-SET PULLEY SYSTEM

5 CROSS-REFERENCE TO A RELATED APPLICATION

This application claims the benefit of U.S. provisional application Serial No. 62/247,938, filed October 29, 2015, which is incorporated herein by reference in its entirety.

0 This invention was made with government support under contract no. W81XWH-13-1-0448 awarded by the Department of Defense. The government has certain rights in the invention.

BACKGROUND OF INVENTION

5 The reference to background art in this specification is not intended to, and should not be taken as, an acknowledgment, statement, suggestion or admission that the referenced prior art forms part of the common general knowledge in Australia or in any other country.

10 After a nerve injury, direct coaptation of the nerve ends provides the most favorable results for nerve regeneration. Successful nerve regeneration can be further promoted if the coaptation site or neurorrhaphy line is separated and isolated from the surrounding tissues, which can inhibit the formation of scar tissue and neuromas. Neuromas often result from nerve fibers or neurons that improperly and irregularly grow into the surrounding tissue. In situations where a nerve is not, or cannot, be repaired, there can be left a nerve stump that must be isolated or covered to minimize or inhibit the formation of painful scar tissue and neuromas, which can cause debilitating pain and, in some instances, even limit or prevent the use of a prosthesis.

25 There are several techniques by which the coaptation site or a nerve stump can be isolated, including the use of a nerve sheath implant, such as a sleeve or cap, into which the nerve ends or the nerve stump, respectively, can be inserted and secured with sutures. The material utilized for a nerve sheath implant should be flexible and capable of being sutured, so that it can be conformed around the nerve to further discourage neuronal outgrowth into the surrounding tissue.

30

5 With nerve coaptation, regeneration is most favorable when the nerve ends are aligned in a nerve repair sleeve so that faces are directed at each other with minimal bunching or deformation. Likewise, nerve stumps often heal more effectively if the nerve face is directed fully into the nerve repair cap and does not fold or bunch-up, which can undesirably encourage nerve fibers to grow out of the cap instead of towards the end of the cap. These configurations can be difficult to achieve when pushing, poking, or otherwise trying to manipulate soft nerve tissue into the aperture, or open end, of a nerve sheath implant.

0 This problem can be partly resolved by utilizing a cap or sleeve that is oversized for the nerve ends being covered. This leaves the necessity, however, of having to meticulously suture the sleeve or cap to the outside of the nerve to reduce diameter and ensure that the nerve ends are sufficiently isolated and separated to discourage neuronal outgrowth into the surrounding tissue.

5 It is well-understood that every puncture, or suture, made within the epineurium or nerve sheath increases the opportunity for neuronal escape and can potentially increase time of healing. Thus, the difficulty of inserting nerve ends into a properly sized sleeve or cap must be weighed against the necessity of having to use additional sutures to secure an oversized sleeve or cap.

10 DEFINITION

10 In the specification the term “comprising” shall be understood to have a broad meaning similar to the term “including” and will be understood to imply the inclusion of a stated integer or step or group of integers or steps but not the exclusion of any other integer or step or group of integers or steps. This definition also applies to variations on the term “comprising” such as “comprise” and “comprises”.

25 BRIEF SUMMARY

30 In accordance with embodiments of the subject invention, the difficulty of inserting a nerve end into a nerve sleeve, nerve cap, or other similarly-used sheathing implant device may in some aspects be addressed by fashioning such nerve sheath devices with pre-set suture pulley systems that can, in one embodiment, be attached to a nerve end and used to pull the nerve end through the aperture, or open end, and into the bore of the implant and in

other embodiments can be used to tighten or cinch the aperture and/or bore of an oversized sheath implant around the periphery of a nerve.

The subject invention in some preferred aspects may at least partially address some of the disadvantages associated with the previously known nerve sheaths, such as nerve sleeve and nerve cap devices, and their methods of use, and provides attributes and advantages that have not been realized by those known devices. In particular, the subject invention provides novel, inexpensive, and highly effective improvements to currently known implant devices used to separate and isolate nerve ends and coaptation sites.

Certain embodiments of a pre-set pulley system can be used to cinch an oversized sheath implant, so as to tighten it around a smaller diameter nerve. This tightening pulley system can have a suture, thread, line, or other flexible elongated material arranged in a specific configuration that traverses through specific points on the sheath implant device. Once a nerve end or nerve ends have been placed within the bore of the implant device, one or more of the lines can be pulled to decrease the diameter (D) of the implant and cinch the bore walls and the aperture around the nerve end or nerve ends.

Other embodiments of a pre-set pulley system can be used to pull or draw the nerve ends into the sheath implant device, so that they come together properly, with minimal bending, crimping, or distortion of the facing end. When coapting two nerve ends within an implant device, such as a nerve sleeve, the facing ends can be properly aligned and spaced using this coapting pulling system. If drawing one nerve end into a nerve cap, the facing end can be fully directed towards the closed end of the nerve cap, to minimize incorrect neuronal growth. This coapting pulley system can position nerve ends more advantageously within the sheath implant device, which can facilitate better and faster healing. With this system, at least one, ideally at least two, sutures, or similar type of device is passed through the wall of a nerve sleeve or nerve cap, so that the tag end of the suture is outside of the implant device bore and the other, needle end, goes through the bore and out of one of the apertures. The needle end can be passed through a nerve, or at least the epineurium, and secured by knotting followed by removal of the needle. The free tag end, outside the bore, can then be pulled away from the bore, which simultaneously draws or pulls the nerve end at the other end of the suture line through the aperture and into the bore.

Variations or combinations of both of these types of pulley systems can be used with nerve repair sleeves and nerve repair caps implanted in patients in need of such treatment.

While the use of the pulley systems can require one or more additional sutures at the nerve end, which has the potential to further damage neurons already in need of repair, it can reduce the number of sutures needed around the aperture to secure the implant device to the nerve. Thus, nerve healing could still be faster or at least no more inhibited by the use of the pulley system. In the case of a nerve stump, neuronal damage at the nerve end is often of minor concern, since reduction in neuronal growth is typically the purpose of utilizing a nerve repair cap.

According to one embodiment there is disclosed an implant comprising a wall that defines a bore having at least one aperture. The at least one aperture is configured to receive at least a portion of a tissue. The implant also comprises at least one pulley system pre-set into the wall comprises at least one flexible strand having a tag end and at least one a needle end, where the at least one flexible strand traverses the wall so that the tag end extends out from the wall and the needle end passes through the bore and out of the at least one aperture for attachment to a tissue in a patient in need of such treatment.

According to another embodiment there is disclosed a method comprising implanting an implant into a patient, wherein the implant comprises a wall that defines a bore having at least one aperture, and at least one pulley system pre-set into the wall before delivery of the implant into the patient and the at least one pulley system includes at least one flexible strand having a tag end and a needle end. A tissue is then attached to the needle end of the flexible strand, the tag end is pulled through the wall of the implant until the tissue attached to the needle end of the suture flexible strand passes through the at least one aperture and into the bore of the implant; and the tag end outside the wall is secured to inhibit movement of the tissue within the bore.

According to a further embodiment there is disclosed an implant comprising a wall that defines a bore having at least one aperture. The wall has a length and the at least one aperture is configured to receive at least a portion of a tissue. The implant has a cinching system pre-set into the wall before delivery of the implant into a patient. The cinching system comprises at least one flexible strand having at least one tag end. A first flexible strand of the at least one flexible strand traverses a first region of the wall in at least one location two locations so that the first flexible strand crosses the bore of the implant at least twice and forms a stitch along an exterior of the wall and along a portion of the length of the wall. The first flexible strand traverses a second region of the wall in at least two locations,

such that the at least one tag end extends through the wall to an exterior of the implant, wherein the second region is spaced apart from the first region in a direction generally perpendicular to the length of the wall.

According to a still further embodiment there is disclosed a method comprising implanting an implant into a patient. The implant comprises a wall that defines a bore having at least one aperture, and wherein the wall has a length; and a cinching system pre-set into the wall before delivery of the implant to the tissue. The cinching system comprises at least one flexible strand having at least one tag end. A first flexible strand of the at least one flexible strand traverses a first region of the wall in at least two locations so that the first flexible strand crosses into the bore of the implant at least twice and forms a stitch along an exterior of the wall and along a portion of the length of the wall, and wherein the first flexible strand traverses a second region of the wall in at least two locations, such that the at least one tag end extends through the wall to an exterior of the implant, wherein the second region is spaced apart from the first region in a direction generally perpendicular to the length of the wall. After implantation, the tissue is positioned within the sheathing through one or more of the at least one apertures and within the implant, the at least one tag end of the first flexible strand is pulled so as to pull the first region and the second region of the wall closer to each other to form puckering of the wall to reduce a size of the bore and the at least one tag end is secured to secure the reduced size of the bore.

BRIEF DESCRIPTION OF DRAWINGS

In order that a more precise understanding of the above recited invention can be obtained, a more particular description of the invention briefly described above will be rendered by reference to specific embodiments thereof that are illustrated in the appended drawings. The drawings presented herein may not be drawn to scale and any reference to dimensions in the drawings or the following description is specific to the embodiments disclosed. Any variations of these dimensions that will allow the subject invention to function for its intended purpose are considered to be within the scope of the subject invention. Thus, understanding that these drawings depict only typical embodiments of the invention and are not therefore to be considered as limiting in scope, the invention will be described and explained with additional specificity and detail through the use of the accompanying drawings in which:

Figure 1 illustrates one embodiment of a sheathing implant nerve cap pre-set with a suture pulley system for dragging a nerve end into the nerve cap. With this embodiment of a nerve cap pulley system, a single suture line is used to traverse both the nerve end and the wall of the cap.

Figure 2 illustrates how the two tag ends of a single suture line of a nerve cap pulley system can be pulled apart to draw tight the suture and to bring a nerve end inside the nerve cap of Figure 1.

Figure 3 illustrates an alternative embodiment of a nerve cap pre-set with a suture pulley system for dragging a nerve end into a nerve cap. With this embodiment of a nerve cap pulley system, two or more suture lines can be used to traverse both the wall of the cap and attach to the nerve end. When the free tag ends of the two or more suture lines outside the wall of the implant are drawn tight, the nerve end can be drawn into the nerve cap.

Figure 4 illustrates the alternative embodiment of a nerve cap pulley system in Figure 3 after it is attached to a nerve end, so the tags of the two or more suture lines can be pulled away from the cap wall so as to drag the nerve end through the aperture and into the bore of the cap.

Figures 5A and 5B illustrate embodiments of cinching pulley systems that can be used to decrease the size of the aperture and/or the diameter (D) of a sheathing implant, so that it can conform to the shape and size of one or more nerve ends therein. Figure 5A shows an embodiment where a single cinching loop is used nearer to an open end(s) of an implant. When the cinching loop is pulled, the apertures are reduced in size and a pucker is formed in the wall at either open end of the implant and the effective diameter of the implant is reduced. In Figure 5B there is shown a single suture line threaded through one side of the implant wall multiple times to create more than one cinching loop, where at least one can be pulled to cinch up the apertures as well as the diameter of the implant.

Figure 6 illustrates how the configuration of the threaded suture line in Figure 5B allows the cinching loop to be used to tighten the suture line, drawing a portion of the wall of the implant together, to create a partitioned area or pucker, which reduces the diameter (D) of the aperture and, as seen here, the diameter of the entire bore.

Figure 7 illustrates an enlarged, end view of a portion of a sheathing implant having a cinching loop system. This illustration shows the pucker formed on one side of the implant wall when the suture is pulled tight to draw a part of the wall together to create the pucker.

Figure 8 is a photograph of two nerve ends that have been drawn into a nerve sleeve sheathing implant utilizing a suture pulley system and a cinching loop to conform the nerve sleeve around the two nerve ends. In this photograph there is shown a pulley system as shown in Figure 1, where a single suture is used on two sides of the nerve.

Figure 9 is a photograph of two ends that have been drawn into a nerve sleeve utilizing a suture pulley system and a cinching loop to conform the nerve sleeve around the two nerve ends. In this photograph, it can be seen how the cinching loop can be tied off, once the pucker is created.

Figures 10A and 10B are enlarged front views and back views, respectively, of the nerve shown in Figure 9. The front and back views shows how the pulley loops can be cut and tied off after the nerve ends are drawn into the tube and opposed to each other.

Figure 11 is an illustration of two embodiments of a multi-pulley system for a nerve sleeve. With this embodiment, at least one suture can be threaded through the implant wall from one aperture to the other aperture of a nerve sleeve so that a pulley loop is formed about the center of the nerve sleeve, which can be used to draw the ends of the nerves into each aperture, as shown at the top of the figure. Alternatively, two separate sutures can traverse the wall so the needle ends extend towards the open end from each aperture and the tag of each suture extends from the wall of the implant.

Figure 12 is an illustration of the multi-pulley system for a nerve sleeve, as shown in Figure 11, with two nerve ends emplaced for attachment to the sutures.

Figure 13 is an illustration of the multi-pulley system for a nerve sleeve, as shown in Figure 12, with the two nerve ends attached to the pulley system.

Figure 14 is an illustration of the multi-pulley system for a nerve sleeve, as shown in Figure 13, where the tags sutured through the nerve ends have been cut and knotted and the pulley loop is beginning to draw the nerve ends into the apertures at either end of the nerve sleeve.

Figure 15 is a photograph showing the sutures of a multi-pulley system for a nerve sleeve being attached to a nerve end. In this photograph, one tag end of a suture has been attached to the nerve end.

Figure 16 is a photograph showing the sutures of a multi-pulley system for a nerve sleeve attached to a nerve end. In this photograph, all of the suture tags have been attached to the nerve end and are also shown going through the wall of the implant.

Figure 17 is a photograph showing the sutures of a multi-pulley system for a nerve sleeve being attached to the ends of a nerve and to the wall of an implant. The four suture tags are placed into the epineurium of the nerve stumps and secured. A cinching loop has also been incorporated with the implant, which is shown here as the knotted loop on the right side of the photograph.

Figure 18 illustrates a multi-pulley system, such as shown in Figure 17, drawing two nerve ends into either end aperture of a nerve sleeve by pulling on the pulley loop on the outside of the wall.

Figure 19 illustrates the multi-pulley system of Figure 18 where the nerve ends have been completely drawn into the nerve sleeve and are adjusted to be sufficiently close that the nerve faces just touch without being crushed together. The pulley loop has also been cut and tied off on the outside of the nerve sleeve wall.

Figure 20 is a photograph showing the multi-pulley system of Figure 19 where the nerve ends have been completely drawn into the nerve sleeve and are adjusted so that the faces of the nerve ends just touch. For the purposes of illustration, the nerve sleeve is larger than required, being approximately 10 mm in diameter with a nerve of approximately 6 mm in diameter.

Figure 21 is a photograph showing a multi-pulley system, such as shown in Figure 19, as well as a cinching loop incorporated with the nerve sleeve. In this photograph, the nerve ends have already been drawn into the nerve sleeve using the tags of the pulley system. The noose knot has not yet been utilized and is shown by the loose looping of the suture within the nerve sleeve.

Figure 22 is a photograph showing the multi-pulley system of Figure 20, where the tags have been pulled tight, cut, and tied off to secure the nerve ends within the nerve sleeve. Manual noose knots of a cinching loop system has also been utilized to create a pucker seen towards the bottom of the photograph. Note that the suture line seen at the bottom of the image is the untied pulley for the opposite side.

Figure 23 is a photograph showing the multi-pulley system of Figure 22 with all pulleys secured.

DETAILED DISCLOSURE

The subject invention pertains to embodiments of a sheathing implant, such as a nerve sleeve, nerve cap, or similar type of flexible implant capable of positioning and isolating nerve ends to facilitate nerve repair or prevent / isolate end bulb neuromas. More specifically, the subject invention provides sheathing implants capable of being used to coapt nerves to each other or to such sheathing implant. In particular there are provided sheathing implants with one or more suture pulley systems that can be used to attach to a nerve end and pull or draw the nerve end into the implant. Other embodiments provide nerve repair sheathing implants with a cinching loop that can be used to conform an implant to the shape and/or size of a nerve therein. These pulley systems can be used independently or in various combinations to effect a safe, secure, easy nerve repair in patients in need of such treatment.

The subject invention is particularly useful in the field of nerve repair, in particular implantable sheathing devices used in the treatment of nerve repair. However, a person with skill in the art will be able to recognize numerous other uses that would be applicable to use with the devices and methods of the subject invention. While the subject application describes, and many of the terms herein relate to, a use for nerve repair and implants used therefor, other modifications apparent to a person with skill in the art and having benefit of the subject disclosure are contemplated to be within the scope of the present invention. By way of non-limiting example, uses for tendon, blood vessel, intestine, or muscle repair are contemplated to be within the scope of the subject invention. Thus, reference herein to a nerve or nerve end should not be construed as limiting the subject invention.

In order to provide a clear and consistent understanding of the specification and claims, including the scope to be given such terms, the following definitions are provided.

The term “patient” as used herein, describes any animal, including mammals, to which the devices and methods of the present invention can be applied and which is in need of such treatment.

The term “surgeon” as used herein is merely for literary convenience. The term should not be construed as limiting in any way. The devices, apparatuses, methods, techniques and/or procedures of the subject invention could be utilized by any person desiring or needing to do so and having the necessary skill and understanding of the invention.

The terms “sheathing implant” or “implant” are also used herein for literary convenience. These terms as used refer to any type of implantable device, usually tubular, in which tissues are emplaced or coated to facilitate isolation and/or repair. This can include, but is not limited to, nerve caps that are placed over the end of a nerve stump or nerve sheaths or nerve sleeves in which two nerve ends are inserted or wrapped. While the subject application is written towards tubular shaped nerve sheath implants, the devices and techniques described herein are not limited to just nerve repair devices.

Furthermore, a sheathing implant useful with the embodiments and techniques of the subject invention is not limited to a particular type of material. Preferably, an implant can be made of a biocompatible material, and while it can be, it does not necessarily have to be, a biodegradable material or other material capable of tissue remodeling. For example, both natural and synthetic biomaterials can be used to manufacture a sheathing implant of the subject invention. In certain embodiments, the biomaterial is a homogenous material. Examples of biomaterials for use in manufacturing the subject invention include, but are not limited to, high density polyethylene (HDPE), polyethylene glycol (PEG) hydrogel, purified proteins from human or animal sources (*e.g.*, membrane of purified collagen or fibrin), and decellularized tissue constructs (*e.g.*, demineralized bone, amnion, SIS, dermis, or fascia). An HDPE or PEG device can comprise or consist of a cylinder of porous HDPE or PEG surrounded by a layer of non-porous HDPE or PEG. Biomaterials that can form a fluid material, such as soluble purified collagen or particulate SIS and dermis, can be directly cast to form the device without a membrane as an intermediate.

In addition, references to “first”, “second”, and the like (*e.g.*, first and second aperture), as used herein, and unless otherwise specifically stated, are intended to identify a particular feature of which there can be at least two. Such reference herein to “first” does not imply that there must be two or more. Furthermore, these references are not intended to confer any order in time, structural orientation, or sidedness (*e.g.*, left or right) with respect to a particular feature.

Finally, reference is made throughout the application to an “open end” and a “closed end.” As used herein, an open end is that end of the device that is uncovered and has an aperture or edge through which a tissue, such as a nerve end, can be drawn or pulled into a sheathing implant. Conversely, a closed end is that end often furthest from the open end or that portion or area of a sheathing implant where the end or face of the tissue to be covered or

coated is situated after being drawn or pulled into the implant. A closed end can be capped so that the implant is a blind hole or, alternatively, it can be an area in the implant where the nerve tissue is completely covered by the walls of the device, which can be, but is not required to be at or near the center of the implant.

5 The present invention is more particularly described in the following examples that are intended to be illustrative only since numerous modifications and variations therein will be apparent to those skilled in the art. As used in the specification and in the claims, the singular for “a,” “an” and “the” include plural referents unless the context clearly dictates otherwise.

0 Reference will be made to the attached figures on which the same reference numerals are used throughout to indicate the same or similar components. With reference to the attached figures, which show certain embodiments of the subject invention, it can be seen that the embodiments of an sheathing implant **50** of the subject invention are generally tubular or can be made tubular, such as in the case of pre-rolled wrapping implants, and include at least
5 one aperture **60**, at an open end **5** through which a tissue can pass, such as, for example, a nerve end that leads to at least one bore **70** defined by a wall **80** in which the tissue, after passing through the aperture, can reside at or near to a closed end **10**. Certain embodiments also include a cap **100** at the closed end for isolating a tissue that is not to be coated to another tissue. The sheathing implant embodiments herein also include at least one of a
10 pulley system **200** that can be used to draw a tissue into the bore and a cinching loop **300** that can be used to tighten a sheathing implant around a nerve end or other tissue. Each of these general components can have one or more sub-components, which will be discussed in detail below.

25 The process of placing a nerve end into a tubular sheathing implant can entail pushing, probing, rotating, or otherwise getting the nerve end through an aperture **60** in the implant. This can be tedious, time-consuming, and can damage the nerve **30** or the nerve face **34** or possibly the implant **50**. The pulley system **200** embodiments of the subject invention provide sheathing implants and methods that can be incorporated with sheathing implants and used to pull a nerve **30** through the aperture of an implant with minimal or no
30 pushing or probing of the nerve end. The cinching loop **300** embodiments of the subject invention can also be incorporated with sheathing implants and used to tighten the implant

around the epineurium **32** or external covering of the nerve **30**. A pulley system and a cinching loop can be used individually or together on a sheathing implant.

In general, a pulley system embodiment utilizes at least one suture **20** that has been pre-set in an implant. The pre-set suture can go through or traverse the implant wall **80** that defines the bore **70** of the implant, so that a needle end **24** of the suture goes through the bore and extends out of the aperture and the opposite end or tag end **26** of the suture extends out from the side of the wall. The needle end can then be used to attach the at least one suture to a nerve end by means of a knot. Once the nerve end has been attached to the suture and the needle removed, the tag end on the outside of the implant wall can be pulled, which in turn pulls the end of the nerve through the aperture and into the bore of the implant. If the suture is attached near to the nerve face **34**, the nerve face will be located approximately where the suture extends out of the wall. Variations of the pulley system can have a single suture that goes through the nerve and traverses the implant wall in two locations or have a single suture that traverses through one side of the wall so that a pulley loop **230** is formed that can be pulled to simultaneously draw or pull two nerves into opposite apertures in a sheathing implant.

A cinching loop embodiment, in general, utilizes at least one suture **20** that has been pre-set in an implant wall. The pre-set suture can go through or traverse the implant wall **80** in at least two or more locations, so that in one embodiment one end is secured outside the wall or so that a portion of the suture forms a stitch **310** parallel to the bore on the outside of the wall. The one or two tag ends of the suture line extend through one side of the bore and out through the wall on the other side of the bore, leaving one or two tag ends **26** of the suture dangling outside the wall opposite to the anchored end or the stitch. The suture tag ends extending out from the wall can be used separately or they can be attached to form a noose knot **315** that, when one suture is pulled away from the implant wall causes the suture line to tighten, pulling the stitch and bringing opposing sides of the wall together, thereby reducing the diameter of the bore and/or the aperture by creating a pucker **320** in the wall. In other words, the implant wall can be cinched up with a suture to tighten it around a nerve in the bore.

In one embodiment, an implant is pre-set with a single suture line. Figures 1 and 2 illustrate an embodiment of a nerve cap having an aperture **60** at one end and a cap **100** at the opposite end, which forms a “blind hole” for a nerve end. A single suture line can be

arranged to traverse the implant wall in two, generally opposite, positions with the nerve end also attached therebetween, as shown in Figure 1. With this embodiment, a suture can be pre-set traversing the implant wall in a first location, so that the needle end **24** passes through the bore and out of the aperture, leaving a suture tag end **26** dangling outside the wall **80**.
5 Alternatively, the can be secured with an anchor **28**, which can be a knot in the tag end or another device or structure to which the tag end is attached, an example of which is shown in Figure 3. The needle end can then be used to pass the suture through the nerve. The needle end can further be passed back through the implant wall at a second location from within the bore, so that the needle end extends out from the wall approximately opposite to the tag end on the other side of the wall. This creates two opposing tag ends **26** extending out from the implant wall and the nerve attached therebetween, again, as shown in Figure 1. When the two suture tag ends **26** are pulled, for example, in opposite directions, the shortening of the suture between the wall locations pulls the nerve through the aperture **60** and into the bore **70** of the implant **50**, as shown, for example, in Figure 2. In a nerve cap implant, this process
5 can place the nerve face **34** against or facing the cap **100**. If necessary, the nerve end can be guided or helped into the aperture using the fingers or surgical tools to manipulate the edges through the aperture. But, the main impetus of force drawing the nerve into the implant can be the pulling of the suture line.

An alternative embodiment utilizes two sutures, each configured with a needle end **24**,
10 and each needle end traversing the wall so that the opposite end or tag end **26** is extending out from the wall **80** and the needle ends extend out of the aperture. Figures 3 and 4 illustrate an example of a nerve cap implant that utilizes this type of pulley system **200** embodiment. In Figure 3 it can be seen that at least two suture lines can be passed through the wall **80** at approximately, but not necessarily, opposite sides. The needle ends **24** can pass through the
25 bore **70** and out of the aperture **60**. The embodiment shown in Figures 3 and 4 have the tag ends secured with anchors **28** that can prevent the tag ends from being accidentally pulled through the wall into the bore. However, the tag ends could be unsecured or dangle freely, as seen in Figures 1 and 2. The needle ends can be passed through a nerve and secured with knots, so that the needle portion is removed. As above, the tag ends can then be pulled away
30 from the wall to draw or pull the nerve through the aperture and into the bore, usually until the nerve face **34** is even, or approximately even, with points where the tag ends exit the bore.

Tissue sheathing implants **50** are not limited to those with a capped end **100**. Others, often referred to as sleeve implants **150**, are designed to cover and protect two coapted nerve ends to facilitate healing. With these types of sheathing implants there can be two open ends with apertures that lead into a central, continuous bore. Nerve ends are placed through the apertures and pushed into the bore towards each other and the closed end or covered portion until their faces are sufficiently close. The aperture is then sutured around the nerve epineurium **32** to hold the sleeve implant and the nerve ends in place.

A pulley system **200** can also be utilized with a sleeve implant **150** having two apertures. In one embodiment, two needle end sutures can be pre-set within a nerve sheath. The needle ends of each suture can each extend through the bore **70** and out of an aperture **60**, such that there are needle ends extending from the aperture at each end of the sleeve implant. Some portion of the suture can traverse the implant wall **80** near the closed end so that tag ends **26** are formed on the outside of the implant sheath, as shown, for example, in Figure 11. In an alternative embodiment, the tag ends can be joined to form a pulley loop **230** on the outside of the wall **80**, which is shown, for example, in Figure 12.

In one embodiment, the needle end of at least two sutures can be passed through the wall leaving tag ends **26** extending out of the wall **80** near the closed end **10** and the needle ends can pass through the bore and out of each aperture **60** for attachment to nerve ends. Figure 11 illustrates an example of this configuration, where one side of the sleeve implant **150** is shown with two tag ends and two needle ends. The alternative embodiment with a pulley loop **230** can be formed by either tying the tag ends **26** together outside of the sleeve wall to form a pulley loop, one example of which is shown in Figure 17, or passing one of the needle ends of a dual needle suture through the wall twice to form a pulley loop outside the wall and at or near the closed end **10**, which is shown, by way of example, on the other side of the sleeve wall in Figure 11.

A pulley loop can be advantageous because it can not only inhibit the suture ends from being pulled through the wall **80** into the bore **70**, thus dismantling the pulley system **200**, but also allows the surgeon to pull on one point **231** to draw two nerve ends into the sleeve implant. This can be achieved with a single suture line forming a pulley loop **230** and each end extending out of one of each of the apertures. Ideally, there are two or more dual needle end sutures configured in the wall with pulley loops, an example of which is shown in Figure 12. A surgeon can attach the two suture ends extending from each open end **5** to a

nerve at each end of the sleeve implant **150**, as shown in Figure 13, 16, and 17. After removing the needle and tying off the suture ends, the surgeon can then pull on each pulley loop **230** to take up the slack in the suture and bring the nerve faces into alignment with the respective apertures. By continuing to pull on the two or more pulley loops, the face ends **34** of the two nerves can be drawn into the opposing sleeve implant apertures at each open end, which is shown, for example, in Figures 18 and 20. Once the faces have been adequately coapted by ensuring that they are in contact, but not crushed or pressed too firmly against each other, the pulley loops can be cut and tied off to secure the nerve ends within the sleeve implant. One example of this is shown in Figure 19. If necessary or desirable, additional sutures can be used to secure the nerve ends and the sleeve implant.

Oftentimes it can be helpful to use an implant **50** that is overly large for the diameter of the nerve or nerves being covered or coapted. This can make it easier to draw a nerve end into the open end **5** of an implant with minimal or no further damage to the nerve face **34**. However, this can leave a larger aperture **60** than desired after the nerve is emplaced and the implant may not provide sufficient protection for the nerve or nerves. One non-limiting example of this is shown in Figure 20, where the diameter (D) of the sleeve is noticeably larger than the circumference of the nerve. In this situation, it can be helpful for the diameter of the implant and/or the aperture to be reduced or tightened around the nerve to protect the neurography line and facilitate healing.

One embodiment of the subject invention is a cinching loop **300** by which either or both the aperture and the implant diameter can be reduced after a nerve or nerves are emplaced therein. This embodiment utilizes a suture line stitched through the implant **50**, so that it crosses the bore **70** at least once, ideally at least twice, and goes through the wall of the implant **50** in two, ideally four, locations—where it goes into the bore and where it comes out of the bore. Where the suture line passes through the bore once, one end can be secured or anchored. Alternatively, where the suture line passes through the bore twice, a stitch **310** can be formed on the outside of the wall, which can secure the suture line. When the ends are tied or otherwise secured together, the suture forms a continuous loop through the implant wall with a noose knot **315** on the outside of the wall and the stitch **310** on the other side of the wall, an example of which is shown in Figure 5A. This allows the cinching loop **300** to be pulled at one point **231** to draw the sides of the wall together at two places at either end of the stitch. This forms a pucker **320** at that point above the wall where the wall is drawn

together and reduces the diameter (D) of the implant. If the cinching loop is near an aperture **60**, such as shown in Figure 5A, pulling the noose knot **315** will cause the stitch to tighten against the wall and can reduce the diameter of the implant at or near the aperture. The circular or continuous loop of the suture advantageously inhibits removal of the cinching loop from the implant.

Alternatively, the suture line of a cinching loop can pass through the bore four times, so as to provide at least one stitch **310** on the outside of the wall and at least two noose knots **315** opposite to the stitch and on the outside of the implant wall **80**, where one noose knot can be pulled to tighten the entire cinching loop system to create a wall pucker **320**. In a particular embodiment, the suture is threaded through the bore to provide at least three noose knots on the outside of the implant wall, where at least one is near to an open end **5**. One example of this multiple noose knot system is shown in Figures 5B and 6. In this example, there is a single stitch **310** on the outside of the wall. When one of the multiple noose knots is pulled away from the wall of the implant **50**, for example, a noose knot near a closed end **10** or cent or the sleeve implant **50**, it causes the wall to come together at all of the points where the suture thread goes through the wall on either side of the bore, which is shown, by way of example, in Figure 7. When the cinching loop is drawn tight, there will be formed a pucker **320** above the wall of the implant, formed by that part of the wall that was pulled together, one example of which is shown in Figures 6 and 8. In a particular embodiment, the threading of the suture forms a noose knot near at least one aperture **60** and at least one other noose knot between the aperture and the closed end. This can reduce the diameter of both the aperture and the bore. If more than two apertures are present, a noose knot can be formed near each, as shown, for example, in Figure 6. In practice, any one or more of these noose knots can be pulled to tighten the entire cinching loop and form the pucker **320**.

Once the noose knot **315** of the one or more cinching loops **300** have been pulled and the sleeve implant wall tightened around the one or more nerve faces **34** being sheathed, the knots can be cut and tied off on the outside of the implant to hold the nerve ends and nerve sheath in position **320**. Excess suture line can also be removed. Examples of this are shown in Figures 9, 10A and 10B where it can be seen that the suture has been drawn tight against the implant to form the pucker **320** and the ends of the noose knots have been tied.

There can be multiple variations of a cinching loop where there are noose knots in specific locations on an implant to allow for strategic tightening of an implant. There can be

more than one cinching loop on an implant, such that an implant could be tightened separately at different locations, such as the embodiment shown in Figure 5A. In addition, while the embodiments described above provide a continuous loop system, variations can have a single suture line passing through the bore one time and going through the wall only twice. With this embodiment, each tag end **26** of the suture can be secured by an anchor **28** or knot to inhibit accidental dismantling of the cinching loop. The opposite or needle end can be pulled to draw the wall together at two points where the suture traverses the wall. While this embodiment is not shown in the attached figures, it is within the skill of a person trained in the art, who has benefit of this disclosure and the figures herein, to configure such a suture arrangement. Variations in the number of cinching loops, stitches, or noose knots on an implant, which provide the same function, in substantially the same way, providing substantially the same result are within the scope of this invention.

It is also possible for a pulley system **200**, described in detail above, to be used on an implant **50** with a cinching loop **300**. This can be advantageous as it would allow a larger diameter implant to be used with the pulley system and allow the implant to be tightened around the nerve afterwards. For example, in Figures 8 and 20, where an implant is significantly larger than the nerve ends therein, a cinching loop can be used in conjunction with the pulley system thereon to tighten the implant around the nerve, protecting the neurography line and promoting healing.

While the embodiments described heretofore provide implants that can be pre-set with one or more pulley systems and/or cinching loop systems, the methods described herein could be practiced using implants that are not pre-set with such systems. Sutures are currently used to secure implants to nerves. The methods described herein could be used to create a pre-set implant just prior to surgery utilizing currently known and used sutures. A suture could be used intraoperatively to create pulley loops on an implant as needed by passing the needle of the suture through the implant. Still further, an implant pre-set with one type of system could be selected for use in a patient and then modified pre-surgically or intraoperatively with sutures to include additional suture motifs, either pulley sutures or cinching sutures. By way of non-limiting example, an implant pre-set with a pulley system could be used to coapt nerves within an implant. After coaptation, sutures could be used to create a cinching loop on the implant to tighten the implant around the coapted nerves.

5 It can be critical that nerve repair after an injury be done quickly and accurately to promote proper healing. Whether it is coaptation of severed nerve ends or capping a nerve end that will not be rejoined, implants are commonly used to facilitate the procedures. The embodiments and methods of subject invention provide implants that have the potential to improve the speed and accuracy at which nerves are repaired. By providing a pulley system on the implant, nerve ends can be quickly drawn into an implant with less prodding and manipulation of the nerve. The cinching systems described herein provide an opportunity to use larger sized implants that can make for easier, less traumatic placement of the nerve and allow the implant to be tightened around the nerve so that it still protects and separates the neurography line from other surrounding tissues and fluids. The methods described herein provide the advantage of allowing a surgeon to utilize materials already used in the surgical suite to create the devices of the subject invention. While this is not an ideal situation, as it can take time and expertise to create a pulley or cinching loop on an implant, it provides an option when such implants are not available or their use was not anticipated.

5 Any reference in this specification to “one embodiment,” “an embodiment,” “example embodiment,” “further embodiment,” “alternative embodiment,” etc., is for literary convenience. The implication is that any particular feature, structure, or characteristic described in connection with such an embodiment is included in at least one embodiment of the invention. The appearance of such phrases in various places in the specification does not necessarily refer to the same embodiment. In addition, any elements or limitations of any invention or embodiment thereof disclosed herein can be combined with any and/or all other elements or limitations (individually or in any combination) or any other invention or embodiment thereof disclosed herein, and all such combinations are contemplated with the scope of the invention without limitation thereto.

CLAIMS

1. An implant comprising:
 - a wall that defines a bore having at least one aperture, wherein the at least one aperture is configured to receive at least a portion of a tissue;
 - at least one pulley system pre-set into the wall before delivery of the implant into a patient, the at least one pulley system comprising:
 - at least one flexible strand having a tag end and a needle end, where the at least one flexible strand traverses the wall so that the tag end extends out from the wall and the needle end passes through the bore and out of the at least one aperture for attachment to a tissue in a patient in need of such treatment.
2. The implant according to claim 1, wherein the implant comprises at least two open ends, and wherein at least two flexible strands are pre-set into the wall so that the tag ends extend from the wall and the needle ends extend out of each aperture.
3. The implant according to claim 2, wherein the tag ends are joined to form a pulley loop that extends from the wall.
4. The implant according to any one of claims 1 to 3 wherein the two tag ends are secured together to form a noose knot external to the implant.
5. The implant according to any one of claims 1 to 4, wherein the implant further comprises a closed end opposite the at least one aperture.
6. The implant according to any one of claims 1 to 5, wherein the implant comprises a cap or a sleeve.
7. The implant according to any one of claims 1 to 6, further comprising:
 - at least one cinching system pre-set into the wall and configured to reduce the size of the implant at least one location, the at least one cinching system comprising:
 - at least one other flexible strand threaded through the wall.

8. The implant according to claim 7, wherein the at least one other flexible strand of the at least one cinching system comprises at least two tag ends, and traverses one a first region of the wall in at least two locations, so that the at least one other flexible strand crosses the bore of the implant at least twice and forms a stitch along an exterior of the wall and along a portion of the length of the wall, and traverses a second region of the wall in at least two locations, such that the at least one tag end extends through the wall to an exterior of the implant, wherein the second region is spaced apart from the first region in a direction generally perpendicular to the length of the wall.

9. The implant according to claim 8, wherein the at least two tag ends are secured together to form a noose knot.

10. The implant according to any one of claims 1 to 9, wherein the implant is made of a biomaterial.

11. The implant according to claim 10, wherein the biomaterial comprises one or more of high density polyethylene, polyethylene glycol hydrogel, purified proteins from one or more of human, animal, plant, fungus, bacterial and synthetic sources, or decellularized tissue constructs.

12. The implant according to any one of claims 1 to 11, wherein the needle end of the at least one flexible strand is configured to pass through at least a portion of the tissue.

13. The implant according to any one of claims 1 to 12, wherein the tissue comprises at least one of a nerve, a tendon, a blood vessel, an intestine, or a muscle.

14. The implant according to any one of claims 1 to 13, wherein the at least one flexible strand includes at least one of a suture, a thread, a line, a wire, or a filament.

15. A method comprising:
implanting an implant into a patient, wherein the implant comprises a wall that defines a bore having at least one aperture, and at least one pulley system pre-set into the wall

before delivery of the implant into the patient, wherein the at least one pulley system includes at least one flexible strand having a tag end and a needle end;

attaching a tissue to the needle end of the flexible strand;

pulling the tag end through the wall of the implant until the tissue attached to the needle end of the flexible strand passes through the at least one aperture and into the bore of the implant; and

securing the tag end outside the wall to inhibit movement of the tissue within the bore.

16. The method according to claim 15, wherein the implant comprises at least two apertures and wherein at least two flexible strands are pre-set into the wall before delivery of the implant into the patient so that the tag ends of the at least two flexible strands extend from the wall and the needle ends of the at least two flexible strands extend out of each aperture, wherein the tag ends of the at least two flexible strands form a pulley loop that extends from the wall, and wherein the step of attaching the tissue to the needle end includes attaching tissue to the needle end of each of the at least two flexible strands, and wherein the method further comprises:

removing a needle from the needle end of each of the at least two flexible strands;

wherein the step of pulling the tag end through the wall of the implant until the tissue attached to the needle end passes through the at least one aperture and into the bore of the implant includes pulling each tag end of the at least two flexible strands through the wall of the implant until tissue attached to each needle end passes through one of the at least two apertures and into the bore of the implant; and

wherein the step of securing the tag end outside the wall to inhibit movement of the tissue within the bore includes securing each tag end of the at least two flexible stands to inhibit movement of the tissue within the bore.

17. The method, according to claim 16, wherein the tag ends of the at least two flexible strands form a pulley loop that extends from the wall.

18. The method according to any one of claims 15 to 17, further comprising making the implant tubular.

19. The method of any one of claims 15 to 18, wherein the tissue attached to the needle end is a nerve tissue, and wherein the step of pulling the tag end through the wall of the implant until the tissue attached to the needle end passes through the at least one aperture and into the bore of the implant pulls an end of the nerve tissue through the at least one aperture and into the bore of the implant.

20. An implant comprising:

a wall that defines a bore having at least one aperture, wherein the wall has a length, and wherein the at least one aperture is configured to receive at least a portion of a tissue;

a cinching system pre-set into the wall before delivery of the implant into a patient, the cinching system comprising,

at least one flexible strand having at least one tag end, wherein a first flexible strand of the at least one flexible strand traverses a first region of the wall in at least two locations so that the first flexible strand crosses the bore of the implant at least twice and forms a stitch along an exterior of the wall and along a portion of the length of the wall, and wherein the

first flexible strand traverses a second region of the wall in at least two locations, such that the at least one tag end extends through the wall to an exterior of the implant, wherein the second region is spaced apart from the first region in a direction generally perpendicular to the length of the wall.

21. The implant according to claim 20, wherein the first flexible strand traverses the second region of the wall in at least two locations, so that at least one noose knot is formed external to the second region of the wall, and wherein the first flexible strand is located proximate to the first aperture of the at least one aperture of the implant

22. The implant according to claim 21, wherein the at least one tag end includes two tag ends, and wherein the two tag ends are connected to form a noose knot external to the implant.

23. The implant according to claim 21 or claim 22, wherein the implant has an end opposite the first aperture;

wherein the at least one flexible strand further includes a second flexible strand located proximate to the end opposite the first aperture, and wherein the end is either closed or has a second aperture; and

wherein the second flexible strand traverses a third region of the wall in at least two locations, so that the second flexible strand crosses into the bore of the implant at least twice and forms a second stitch along the exterior of the wall and along a portion of the length of the wall, and wherein the second flexible strand traverses a fourth region of the wall in at least two locations, such that at least one tag end of the second flexible strand extends through the wall to the exterior of the implant, and forms at least one other noose knot external to the fourth region of the wall, and wherein the fourth region is spaced apart from the third region in a direction generally perpendicular to the length.

24. The implant according to any one of claims 21 to 23, wherein the at least one tag end includes two tag ends, and wherein the two tag ends are secured together external to the implant.

25. The implant according to any one of claims 21 to 24, wherein the first flexible strand traverses the second region of the wall in at least six locations, so that a plurality of tag ends extend external to the second region of the wall, and wherein at least one pair of the plurality of tag ends are coupled together to form one or more noose knots external to the second region of the wall.

26. The implant according to any one of claims 21 to 25, wherein pulling the at least one tag end of the first flexible strand pulls the first region and the second region of the wall closer to each other to form a puckering of the wall to reduce a size of the bore.

27. The implant of any one of claims 21 to 26, wherein the implant is formed of a biomaterial that comprises one or more of high density polyethylene; polyethylene glycol hydrogel; purified proteins from one or more of human, animal, plant, fungus, bacterial, and synthetic sources; or decellularized tissue constructs.

28. The implant according to any one of claims 21 to 27, wherein the implant has been made tubular.

29. The implant according to claim 28, wherein the implant has been pre-rolled.

30. The implant according to claim 27 or claim 28, wherein the implant has two apertures.

31. The implant according to claim 21, wherein the implant is tubular.

32. The implant according to any one of claims 21 to 31, wherein the implant has one aperture and a closed end opposite the one aperture.

33. A method comprising:

implanting an implant into a patient, wherein the implant comprises:

a wall that defines a bore having at least one aperture, and wherein the wall has a length; and

a cinching system pre-set into the wall before delivery of the implant to the tissue, wherein the cinching system comprises:

at least one flexible strand having at least one tag end, wherein a first flexible strand of the at least one flexible strand traverses a first region of the wall in at least two locations so that the first flexible strand crosses into the bore of the implant at least twice and forms a stitch along an exterior of the wall and along a portion of the length of the wall, and wherein the first flexible strand traverses a second region of the wall in at least two locations, such that the at least one tag end extends through the wall to an exterior of the implant, wherein the second region is spaced apart from the first region in a direction generally perpendicular to the length of the wall;

positioning tissue through one or more of the at least one apertures and within the implant;

pulling the at least one tag end of the first flexible strand so as to pull the first region and the second region of the wall closer to each to form puckering of the wall to reduce a size of the bore; and

securing the at least one tag end to secure the reduced size of the bore.

34. The method according to claim 33, wherein the implant has an end opposite the first aperture;

wherein the implant further comprises:

a second flexible strand located proximate to the end opposite the first aperture wherein the second flexible strand includes at least one tag end, and wherein the end is either closed or has a second aperture, wherein the second flexible strand traverses a third region of the wall in at least two locations, so that the second flexible strand crosses the bore of the implant at least twice and forms a second stitch along the exterior of the wall and along a portion of the length of the wall, and wherein the second flexible strand traverses a fourth region of the wall in at least two locations, such that the at least one tag end of the second flexible strand extends through the wall to the exterior of the implant, and forms at least one noose knot external to the fourth region of the wall, wherein the fourth region is spaced apart from the third region in a direction generally perpendicular to the length of the wall;

wherein the method further comprises pulling the at least one noose knot; and

wherein the method further comprises securing the at least one noose knot to secure the reduced size of the bore.

35. The method according to claim 34, wherein the at least one flexible strand includes at least two tag ends that extend external to the implant,

wherein the method further includes connecting the at least two tag ends to form at least one noose knot external to the implant,

wherein the step of pulling the at least one tag end of the first flexible strand includes pulling the at least one noose knot so that the stitch pulls the first region and the second region of the wall closer to each other to form the puckering in the wall; and wherein the step of securing the at least one tag end to secure the reduced size of the bore includes securing the at least one noose knot.

36. The method according to any one of claims 33 to 34, wherein the first flexible strand traverses the second region of the wall in at least six locations, so that a plurality of tag ends extend external to the second region of the wall, and wherein at least one pair of the plurality of tag ends are coupled together to form one or more noose knots external to the second region of the wall;

wherein the step of pulling at least one tag end of the first flexible strand includes pulling at least one noose knot of the one or more noose knots; and

wherein the step of securing the at least one tag end to secure reduced size of the bore includes securing the at least one noose knot of the one or more noose knots.

37. The method according to any one of claims 33 to 36, further comprising a second flexible strand including at least two tag ends, wherein the at least two tag ends of the second flexible strand are connected to form at least one other noose knot, and wherein the method further comprises:

pulling the at least one other noose knot to pull the first region and the second region of the wall together and form the puckering in the wall; and

securing the at least one pulled noose knot to secure the puckering in the wall.

38. The method according to any one of claims 33 to 37, wherein the first flexible strand is proximate to a first aperture of the at least one aperture of the implant.

39. The method according to any one of claims 33 to 38, wherein the tissue positioned within the implant through one or more of the at least one apertures is a nerve tissue.

40. The method according to any one of claims 33 to 39, further comprising making the implant tubular.

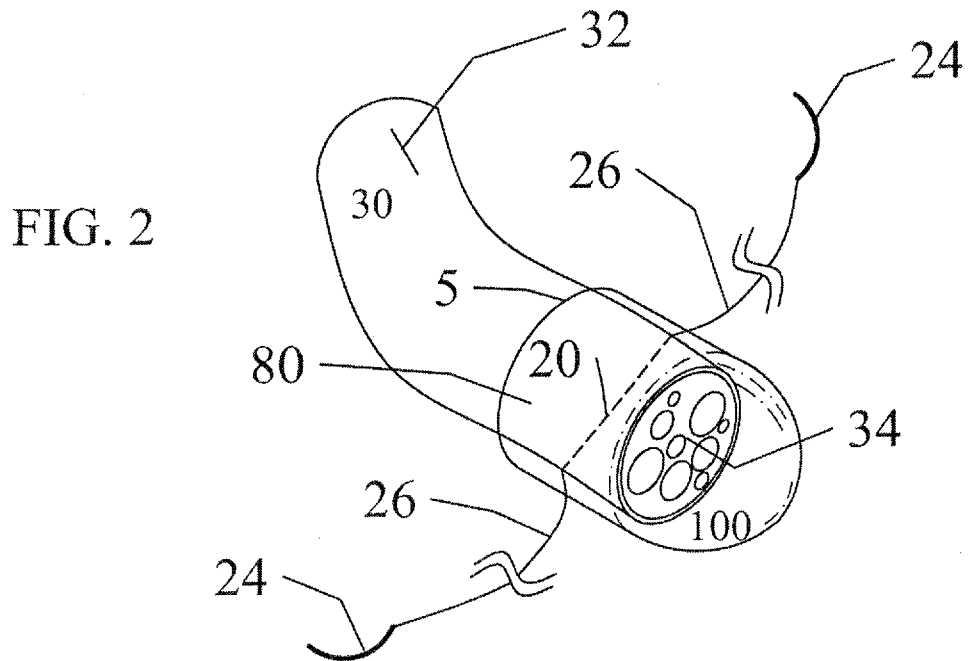
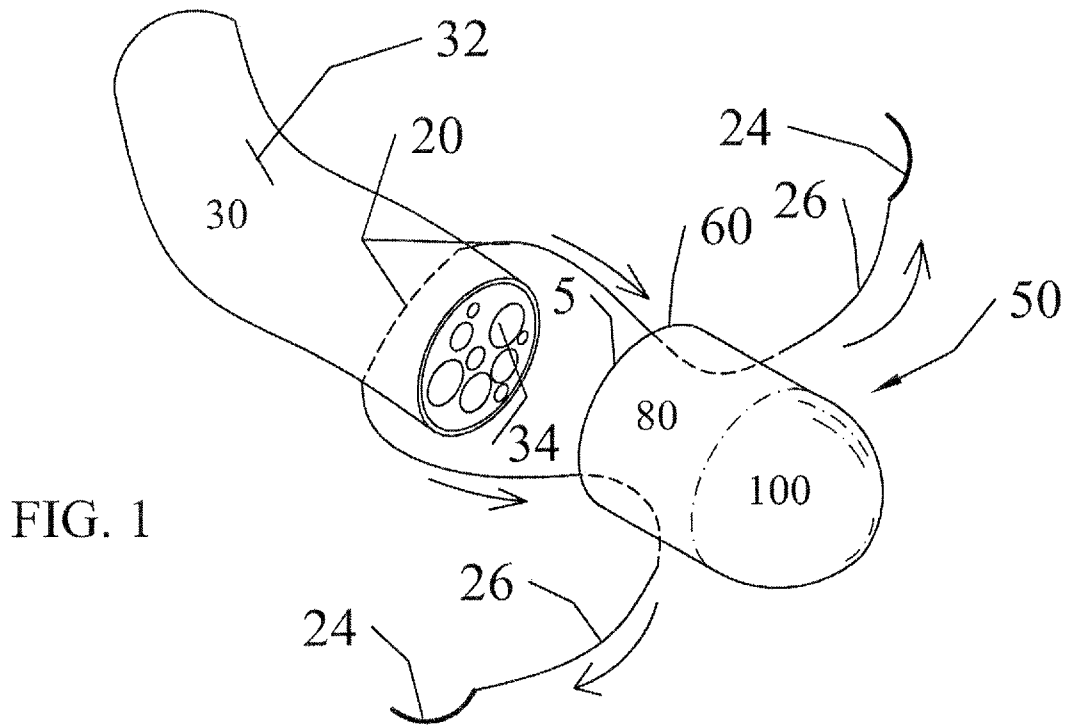

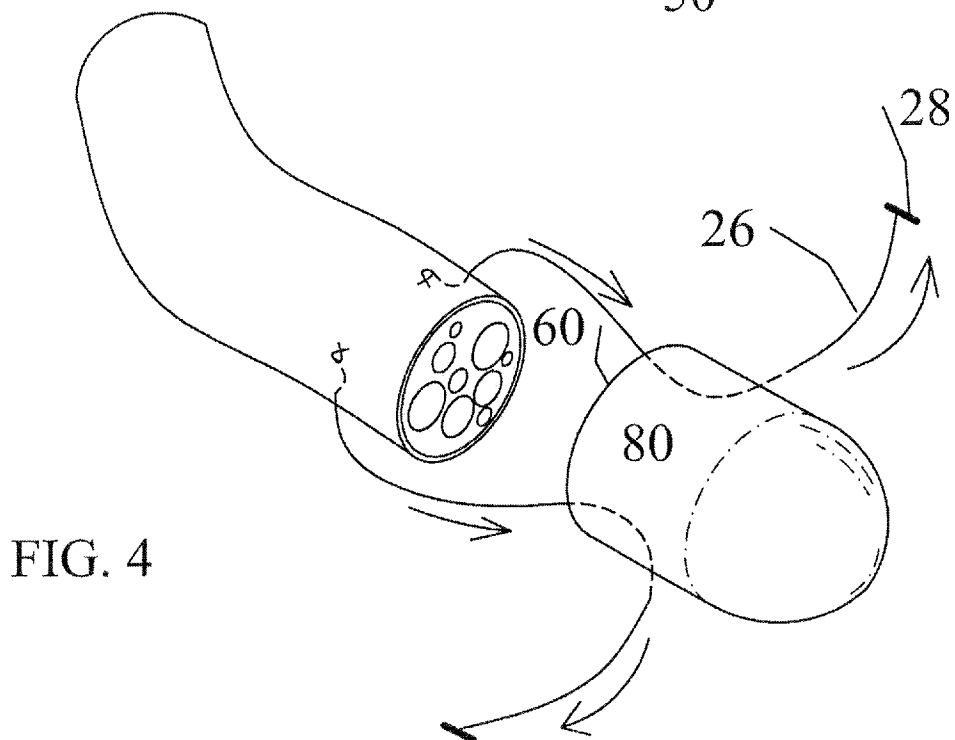
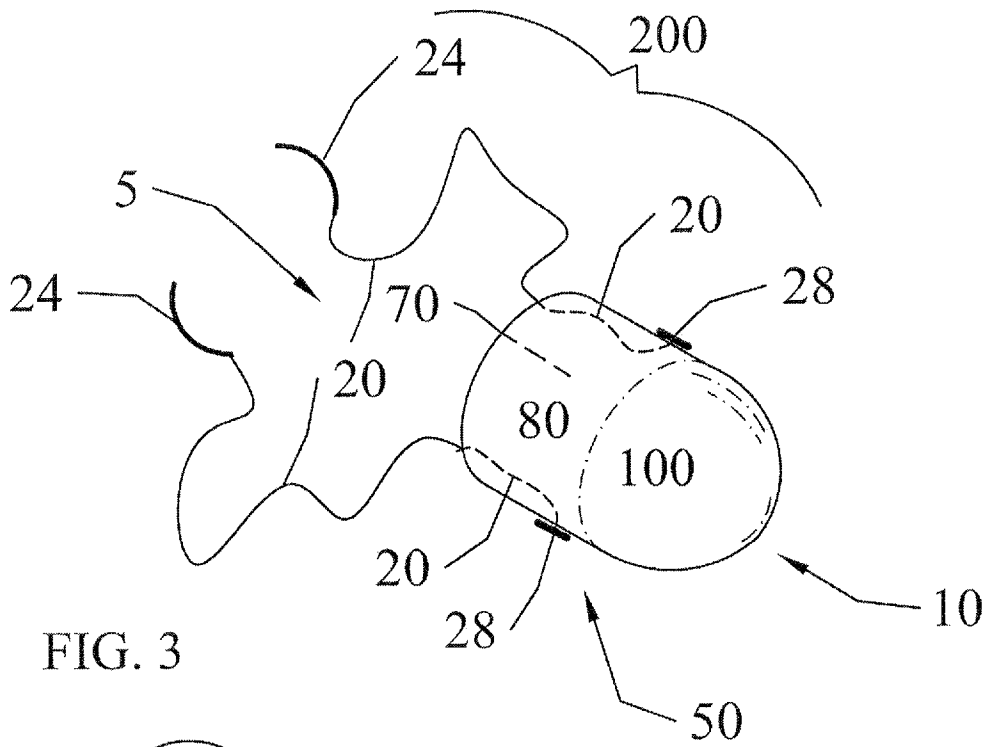

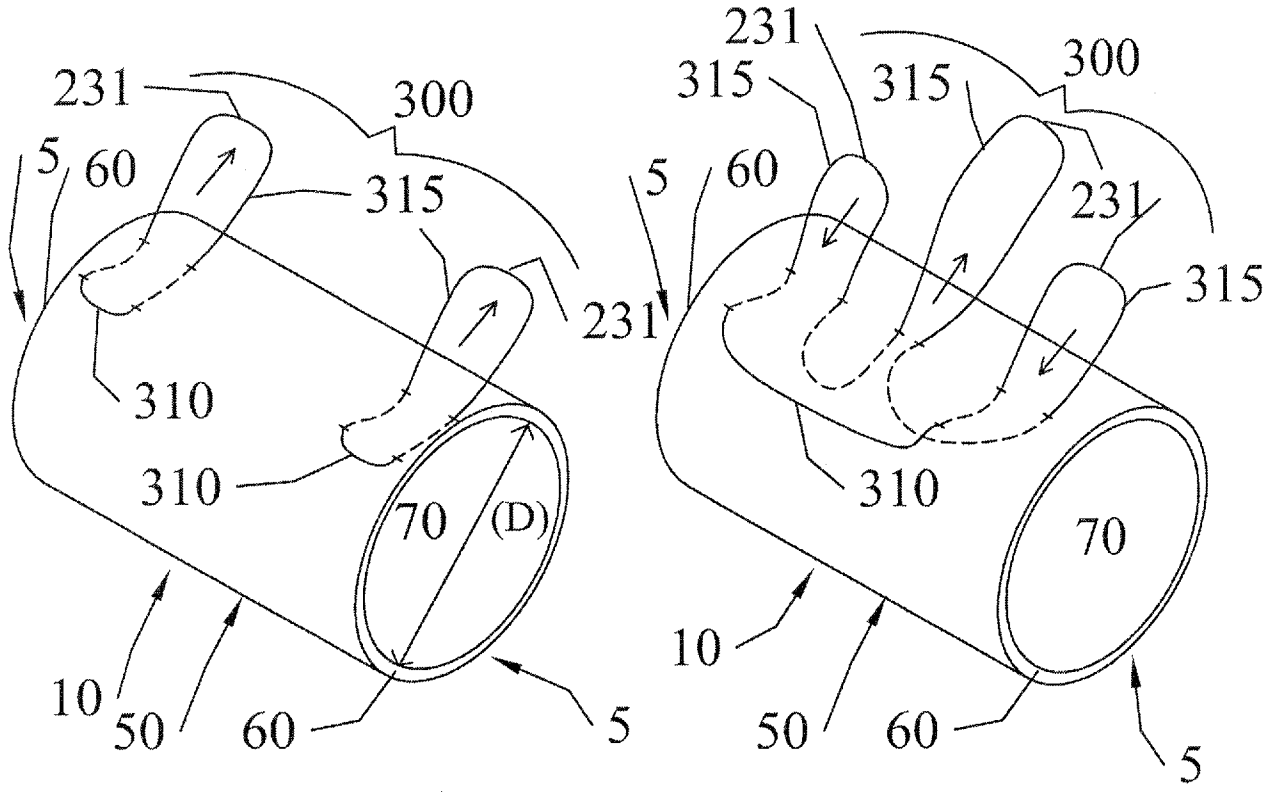

FIG. 5A

FIG. 5B

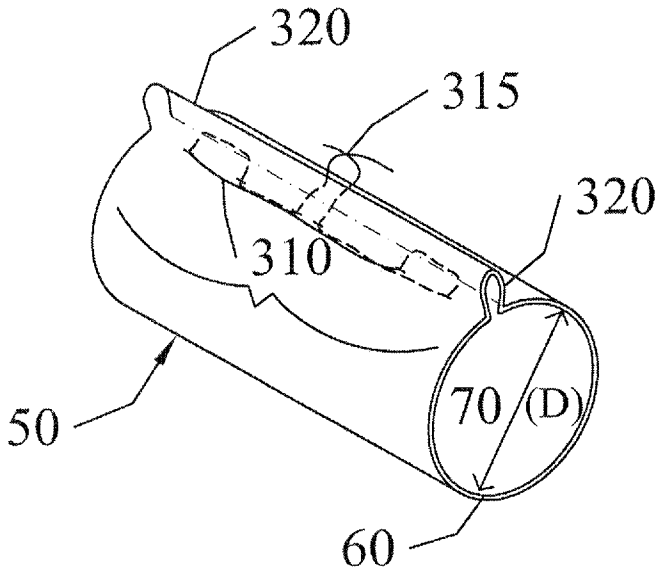

FIG. 6

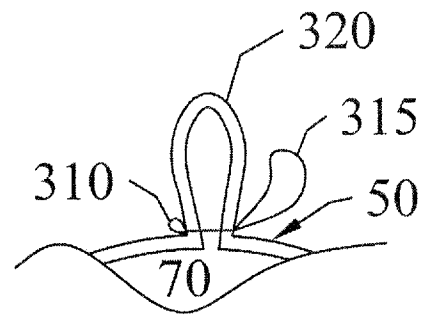
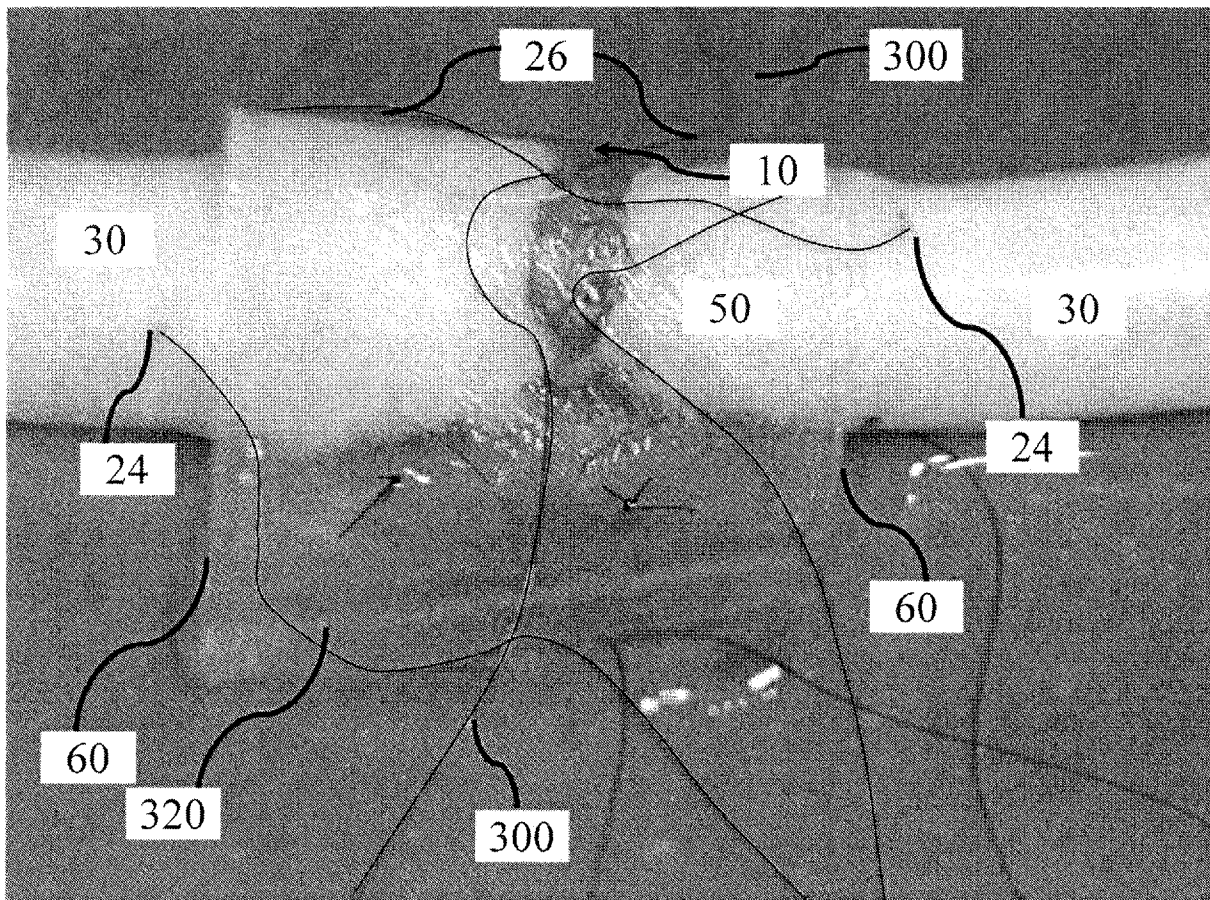

FIG. 7

Manual Cinching



- Note that some pulley arms were crossed. This is an error but did not affect the use

FIG. 8

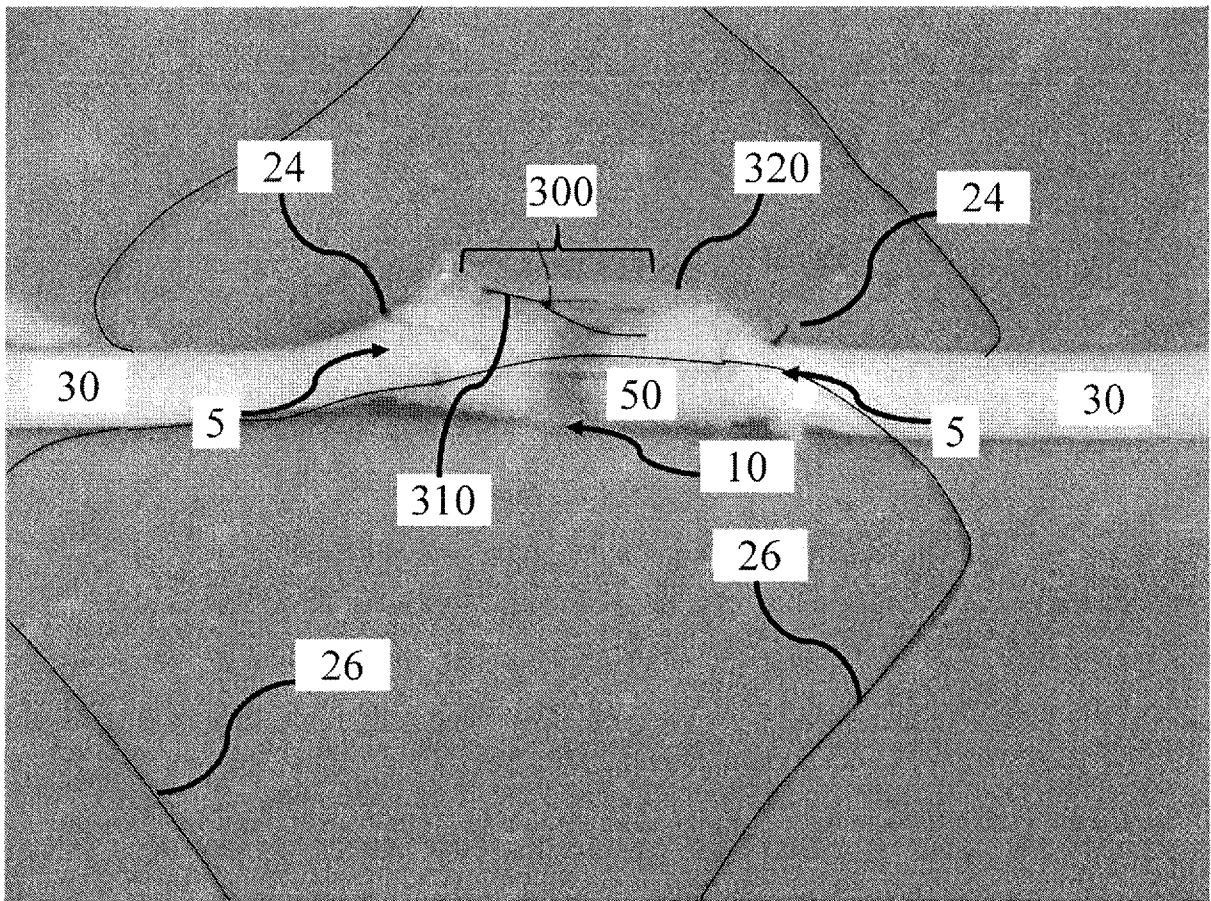

- Cinch pulled tight resulting in better fit of conduit

FIG. 9

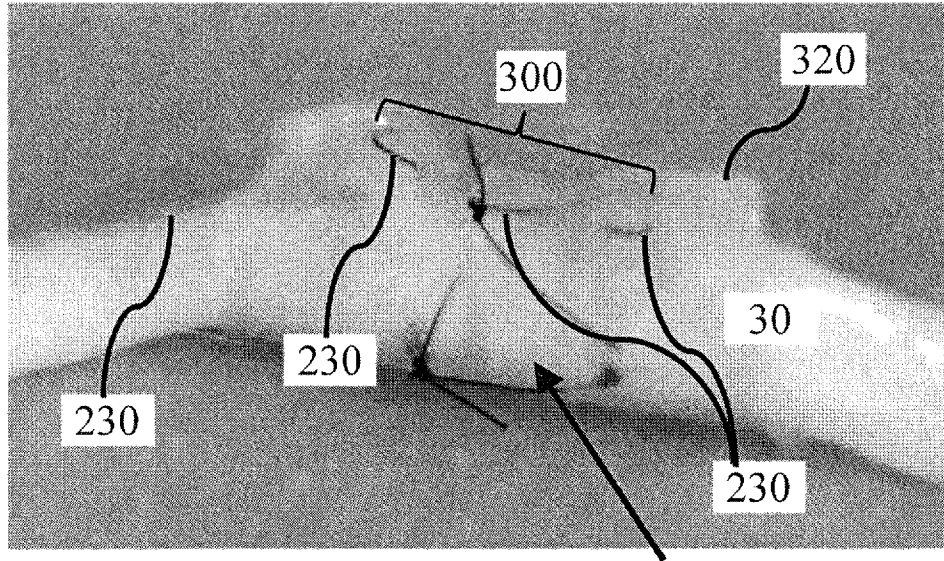

Neurorraphy line, note the ends are just touching

Front view

FIG. 10A

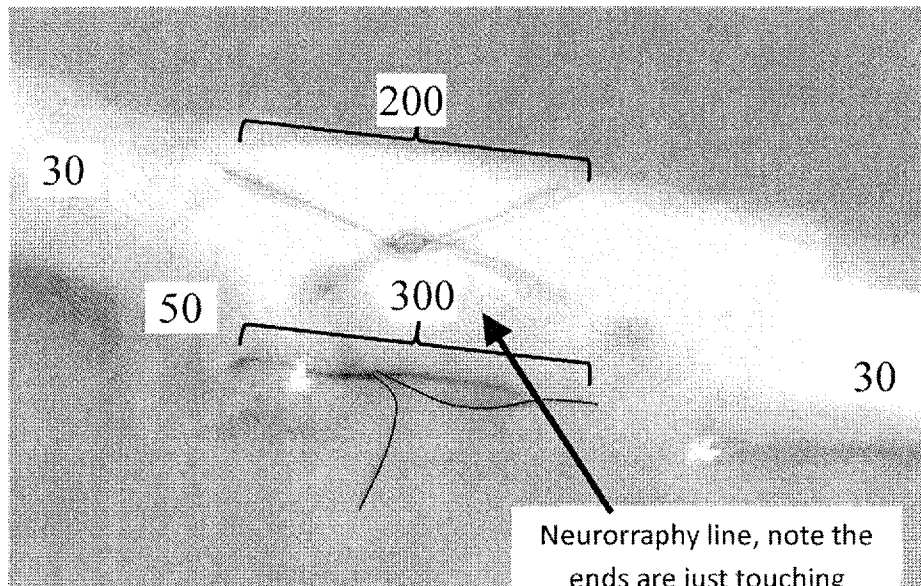

Neurorraphy line, note the ends are just touching

Back view

FIG. 10B

FIG. 11

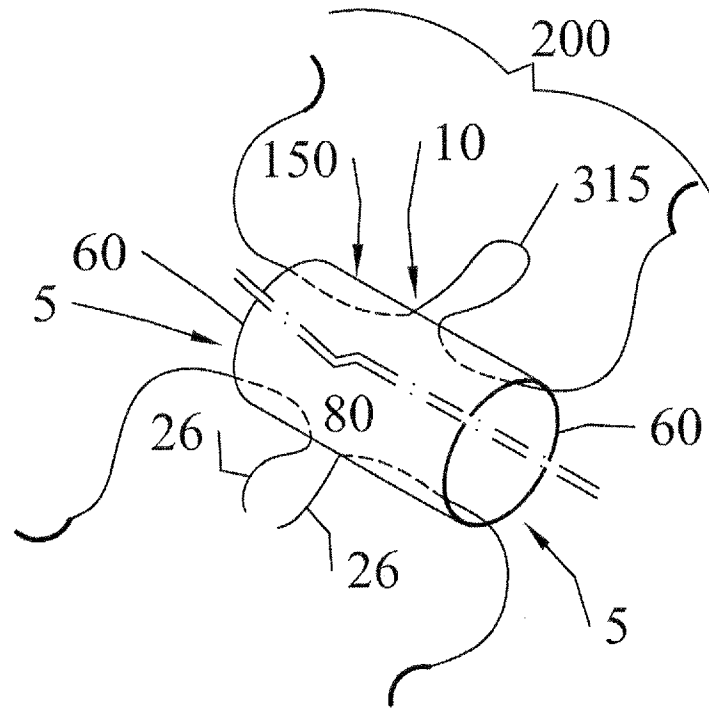
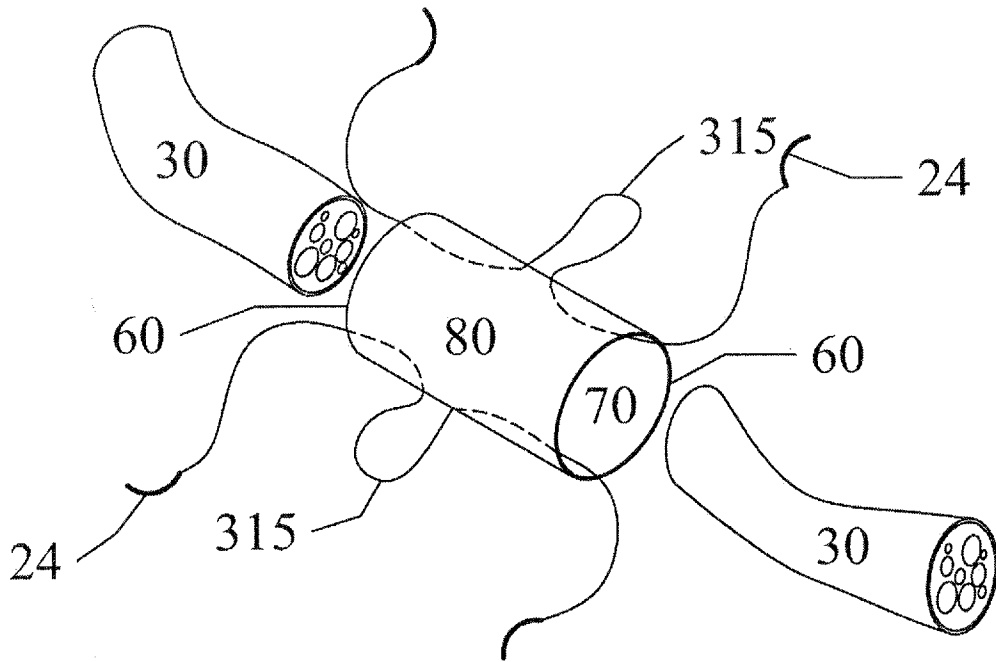
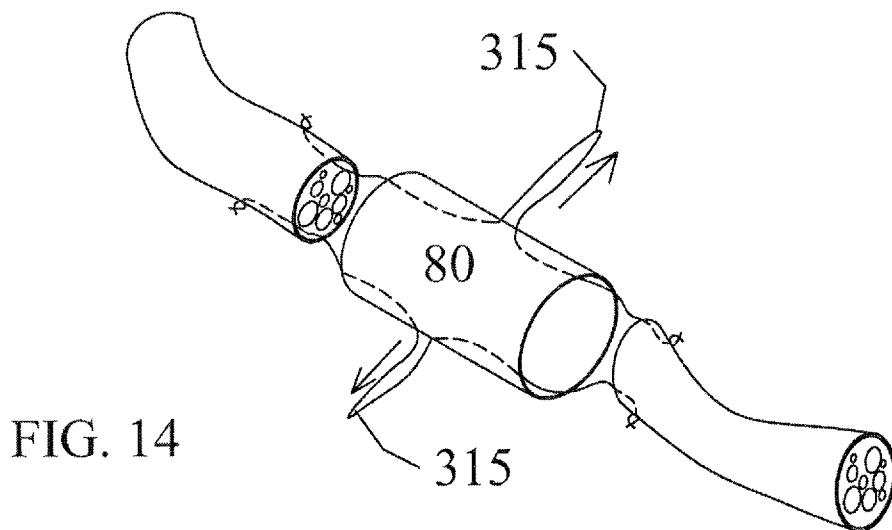
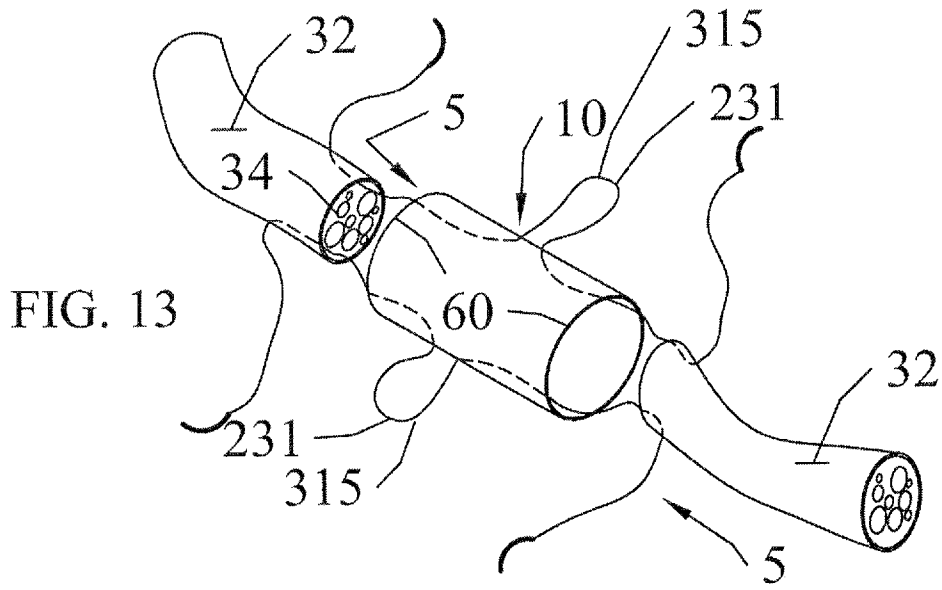

FIG. 12





9/14

FIG. 15

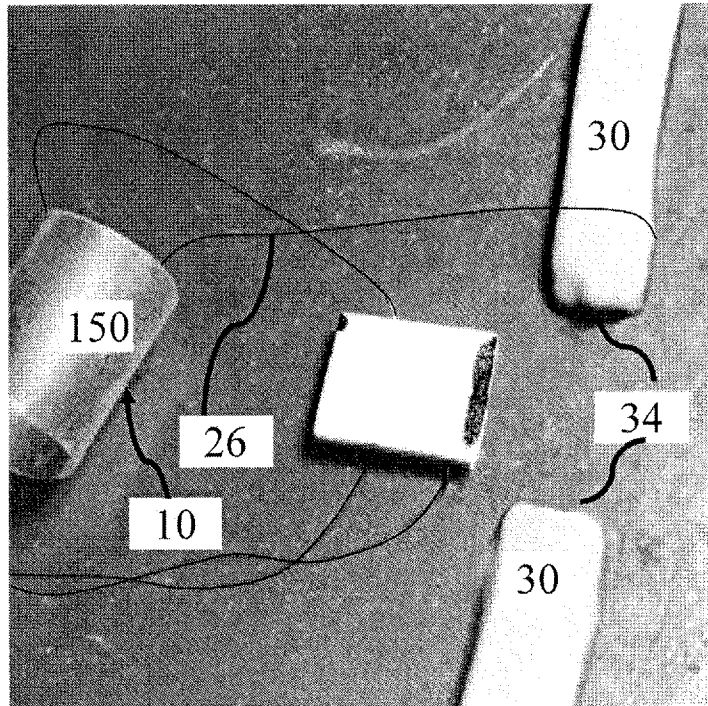

1 arm attached to nerve

FIG. 16

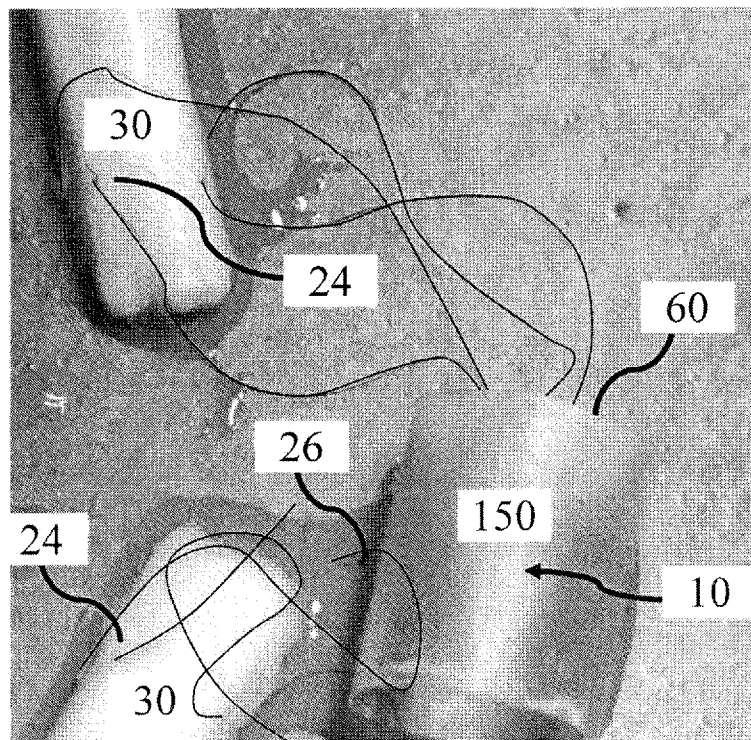

All arms attached to nerve (8 total; 4 pulleys)

10/14

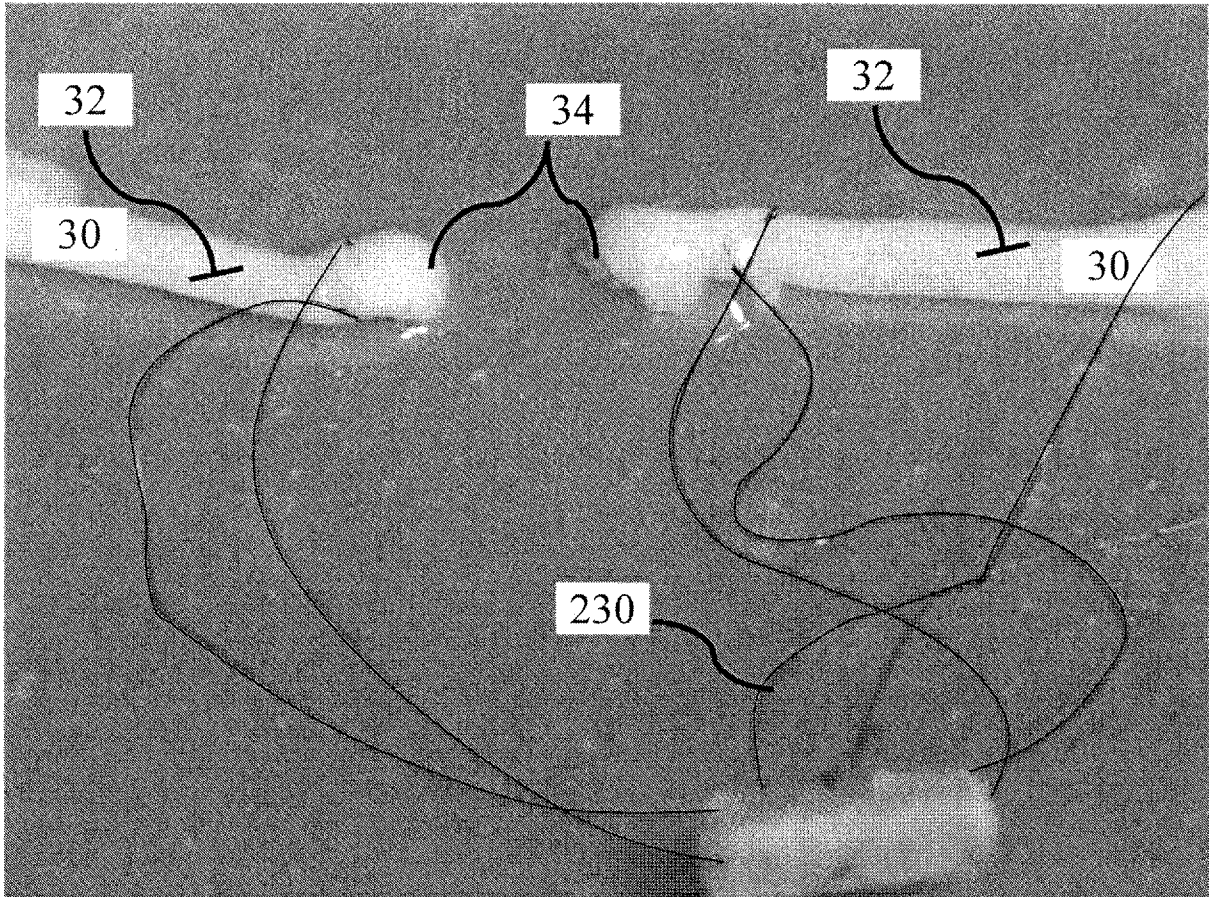

All arms attached to nerve (4 total; 2 pulleys).
Note pre-sutured cinch also present

FIG. 17

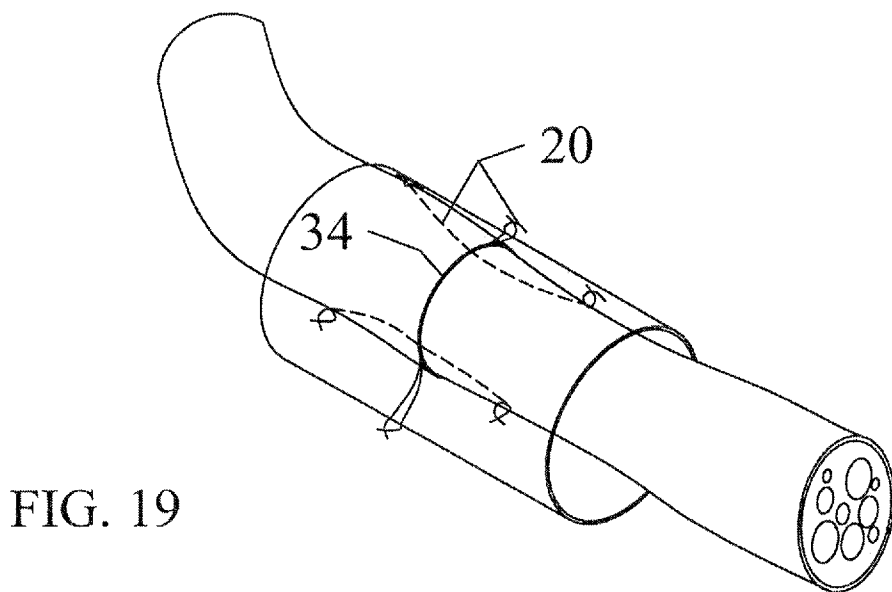
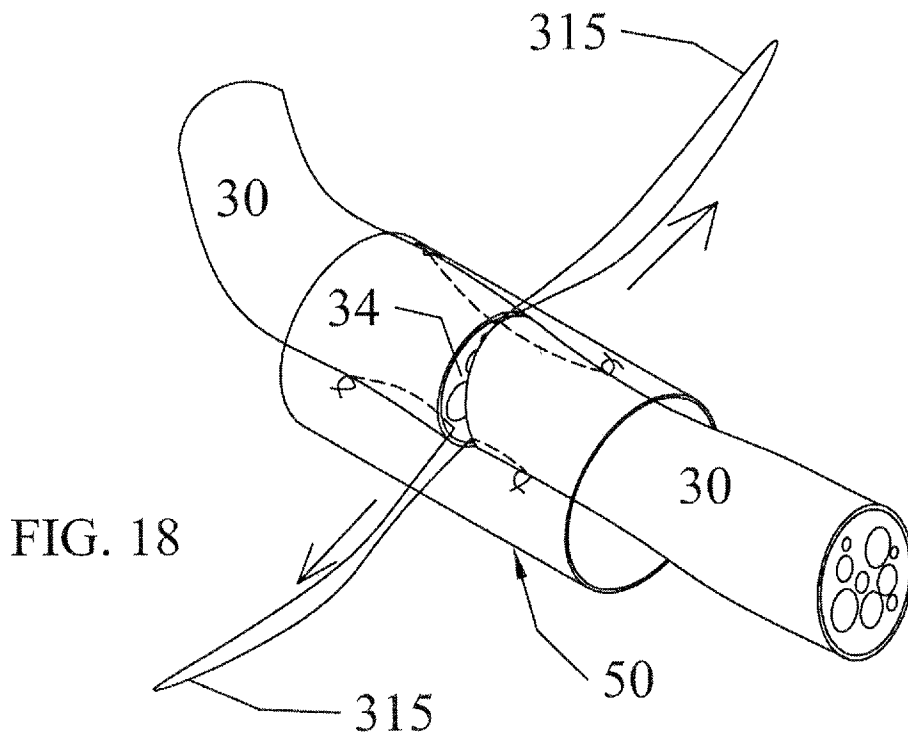

Initial draw in of nerve into conduit

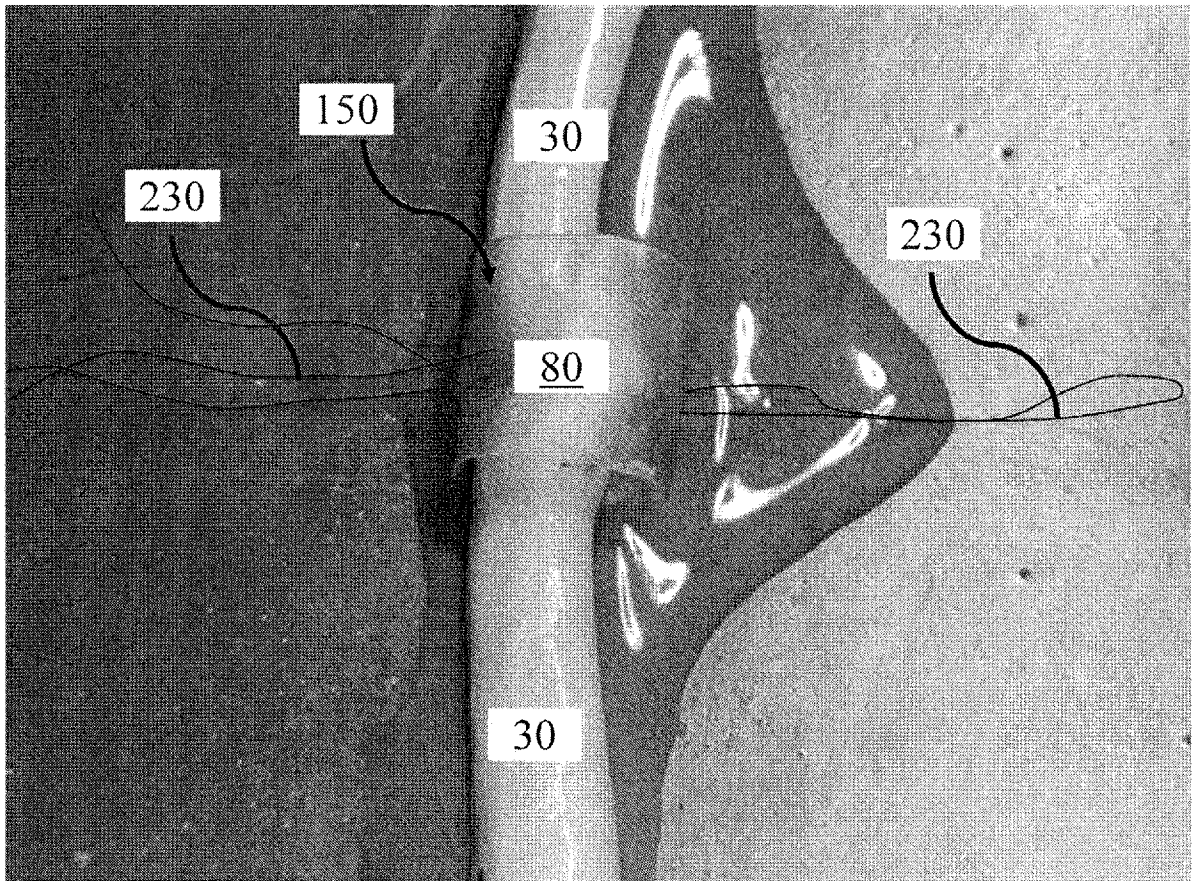

- Note that conduit is greatly oversized for purposes of this handling (10mm conduit on ~6mm nerve)

FIG. 20

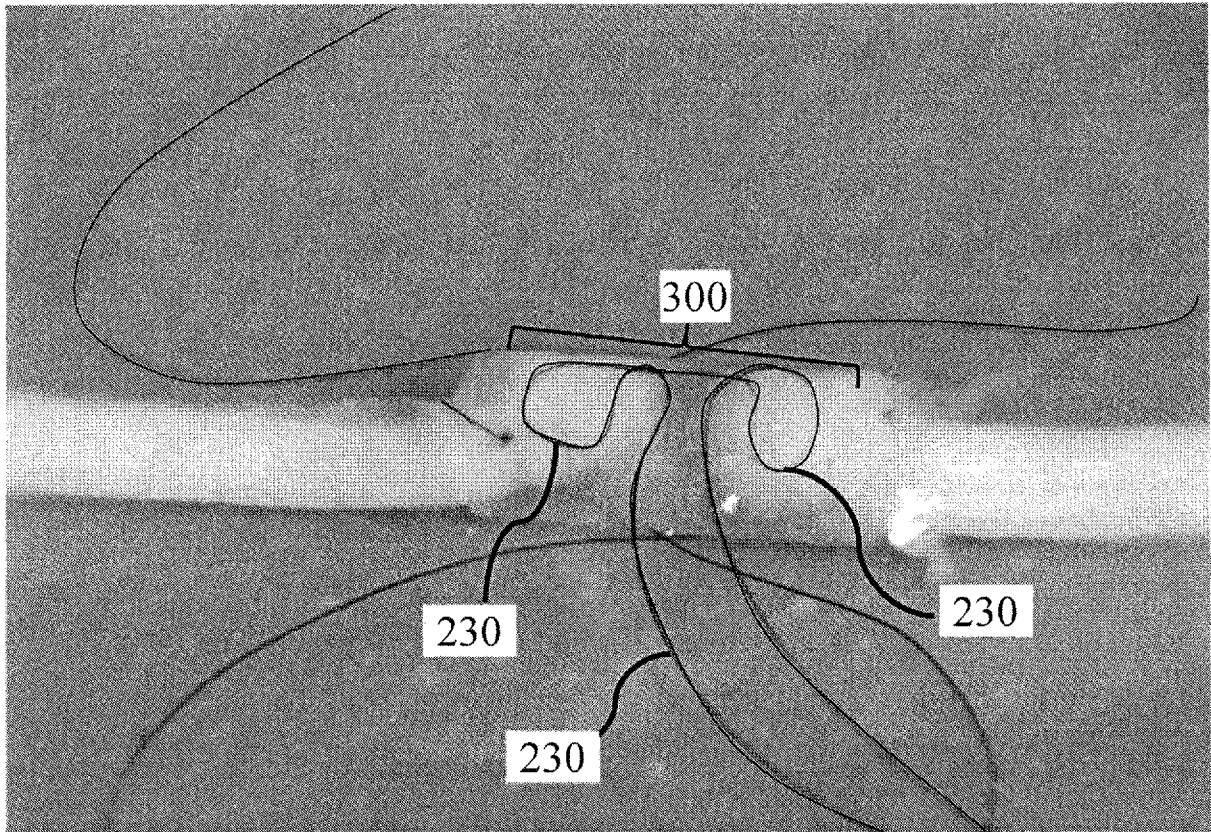

- 2mm conduit on 1-1.5mm nerve

FIG. 21

FIG. 22

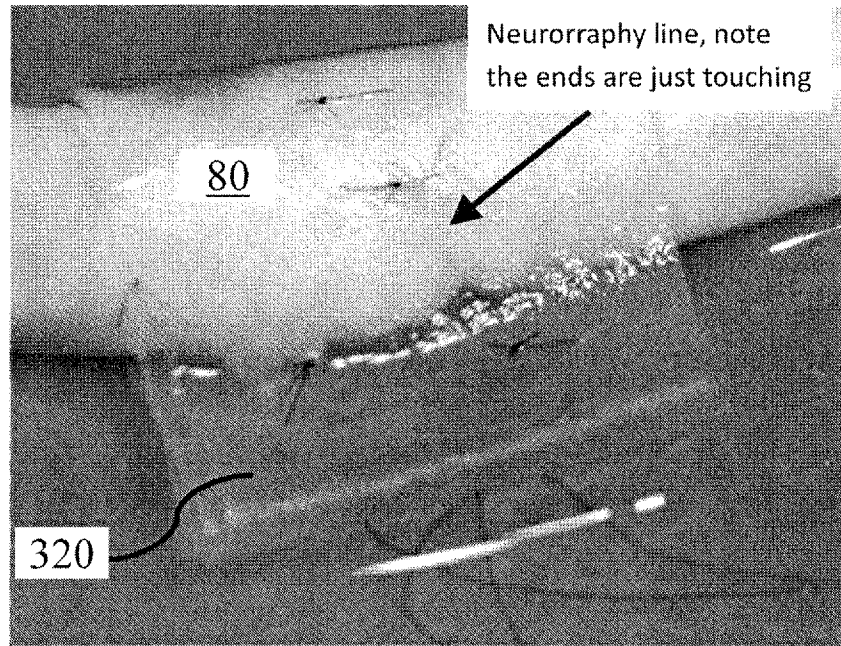

2 pulleys drawn in and tied off (front)

FIG. 23

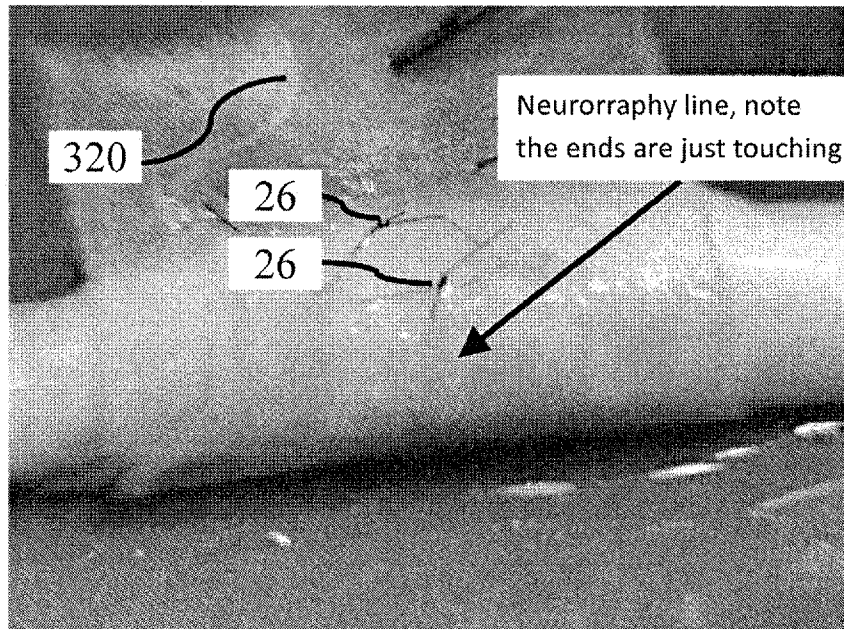

All pulleys drawn in and tied off