

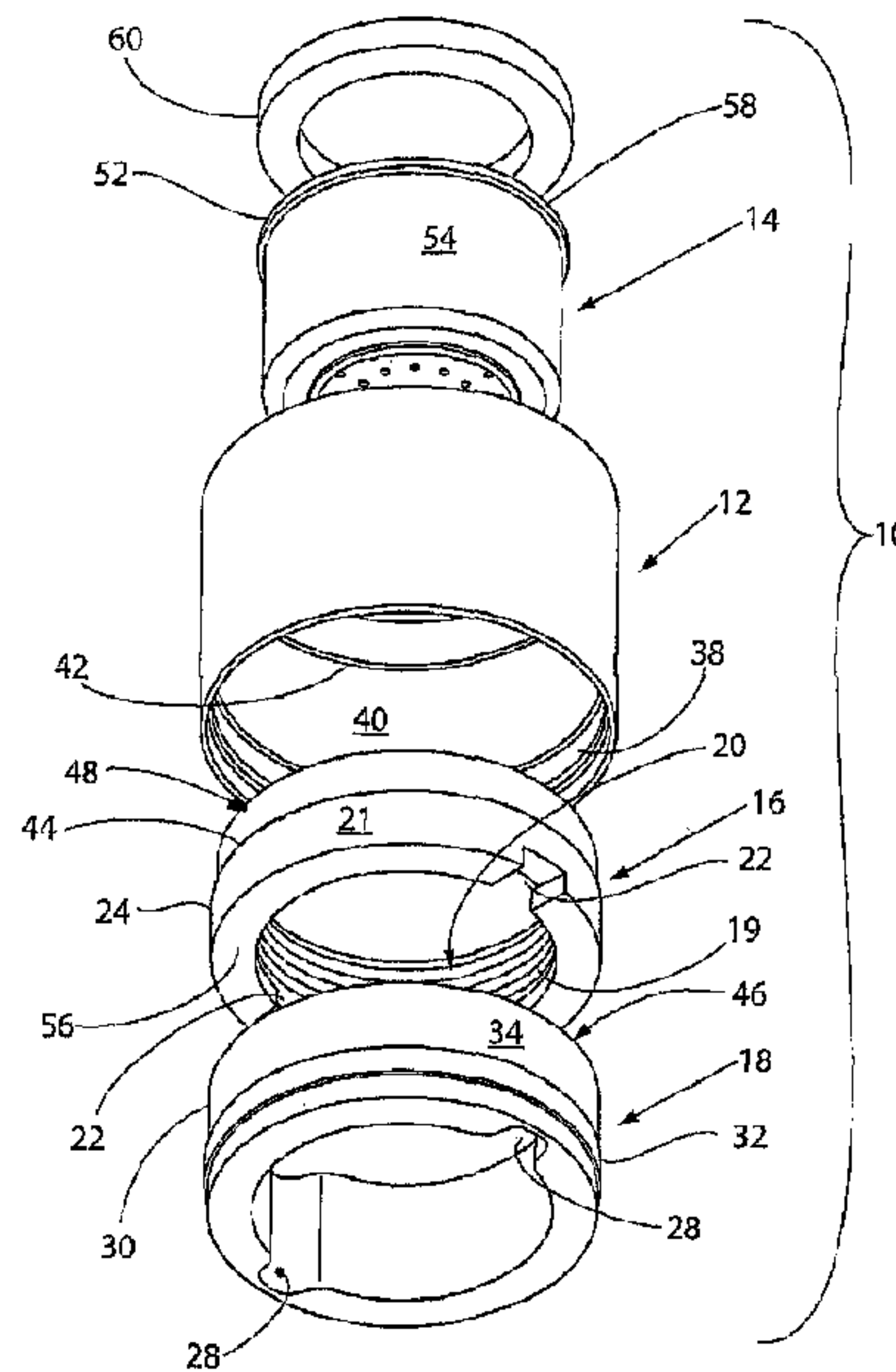

(22) Date de dépôt/Filing Date: 2014/03/14
(41) Mise à la disp. pub./Open to Public Insp.: 2014/09/25
(45) Date de délivrance/Issue Date: 2019/02/19
(62) Demande originale/Original Application: 2 902 725
(30) Priorités/Priorities: 2013/03/15 (US61/787,162);
2014/03/13 (US14/208,962)

(51) Cl.Int./Int.Cl. *E03C 1/084* (2006.01)
(72) Inventeur/Inventor:
BUSH, SHAWN D., US
(73) Propriétaire/Owner:
SDB IP HOLDINGS, LLC, US
(74) Agent: PIASETZKI NENNIGER KVAS LLP

(54) Titre : AERATEUR INVOLABLE A DOUBLE ACTION ET SYSTEME D'AERATEU
(54) Title: DOUBLE-ACTING TAMPER-RESISTANT AERATOR AND AERATOR SYSTEM



(57) **Abrégé/Abstract:**

A tamper-resistant aerator including an aerator cartridge, an insert defining at least one removal slot, and a locking ring defining at least one removal slot at least partially disposed within a housing is disclosed and extending substantially the entire height of the locking ring. The locking ring rotates with respect to the housing to allow alignment of the removal slot of the locking ring with the removal slot of the insert. Alignment of the slots forms a continuous passageway through the locking ring and into the insert. A mating engagement between the locking ring and the housing secures the locking ring within the housing while allowing it to rotate with respect to the housing. An aerator system is also provided comprising an aerator as described above and a tool adapted to be received in the continuous passageway formed by the alignment of the slots and engage the insert.

ABSTRACT

A tamper-resistant aerator including an aerator cartridge, an insert defining at least one removal slot, and a locking ring defining at least one removal slot at least partially disposed within a housing is disclosed and extending substantially the entire height of the locking ring. The locking ring rotates with respect to the housing to allow alignment of the removal slot of the locking ring with the removal slot of the insert. Alignment of the slots forms a continuous passageway through the locking ring and into the insert. A mating engagement between the locking ring and the housing secures the locking ring within the housing while allowing it to rotate with respect to the housing. An aerator system is also provided comprising an aerator as described above and a tool adapted to be received in the continuous passageway formed by the alignment of the slots and engage the insert.

DOUBLE-ACTING TAMPER-RESISTANT AERATOR AND AERATOR SYSTEM

BACKGROUND OF THE INVENTION

Field of the Invention

[0001] The present invention relates to a tamper-resistant aerator and a tamper-resistant aerator system for use on a faucet. More specifically, the invention is directed to an aerator having a rotatable locking ring that increases the difficulty of unauthorized removal of the aerator from the faucet and an aerator system that also includes a tool adapted for installation and removal of the aerator.

Description of Related Art

[0002] Prior art tamper-resistant aerators require a special tool very similar to a spanner style wrench to remove the aerator from a faucet. The removal tool typically has two prongs on the end that correspond to small slots on the aerator itself. Once these prongs are inserted into the slots on the aerator, the tool is used to unscrew the aerator from the faucet. However, makeshift tools can be fashioned out of many different objects to recreate the abilities of the special tool giving an unauthorized user full ability to remove the tamper-resistant aerator from the faucet. This is a particular issue in the case of public restrooms and the like where the aerators can be easily stolen using such a makeshift tool.

SUMMARY OF THE INVENTION

[0003] In accordance with an embodiment of the present invention, a tamper-resistant aerator includes a housing, an aerator at least partially disposed within the housing, an insert engaged with a portion of the housing, with the insert defining at least one removal slot adapted to receive at least a portion of a tool, and a locking ring at least partially disposed within the housing. The locking ring defines at least one removal slot adapted to receive at least a portion of the tool, with the locking ring rotatable relative to the housing. The locking ring is rotatable to align the at least one removal slot of the insert with the at least one removal slot of the locking ring.

[0004] In certain configurations, the tamper-resistant aerator also includes a mating engagement between the locking ring and the housing, in which the mating engagement is adapted to secure the locking ring within the housing. The mating engagement may include at least one protrusion on an exterior surface of the locking ring and a corresponding indentation on an interior surface of the housing adapted to receive the protrusion. The protrusion may be a circumferential ring around the exterior surface of the locking ring and

the indentation may be a circumferential groove in the interior surface of the housing. In certain configurations, the mating engagement is an interference engagement.

[0005] In various embodiments, alignment of the at least one removal slot of the locking ring with the at least one removal slot of the insert forms a continuous passageway through a sidewall of the locking ring and at least partially through a sidewall of the insert. The locking ring may have two slots placed on opposite sides of a circumference of the locking ring, and the insert may have two slots placed on opposite sides of a circumference of the insert. An interior surface of the housing may include a protrusion, and an exterior portion of the insert may abut the protrusion, when the insert is secured within the housing by the protrusion and the locking ring.

[0006] The aerator may include an aerator cartridge, and the aerator cartridge and the insert may engage each other to secure the aerator cartridge within the housing. The insert may also include an extension projecting into an inner diameter of the insert, with the aerator cartridge including an extension projecting outwardly from an exterior surface of the aerator cartridge that is configured to engage the extension of the insert.

[0007] Optionally, the extension on the insert and the extension on the aerator form a ledge. The tamper-resistant aerator may also include a rubber gasket disposed within the insert and resting on a top surface of the aerator cartridge.

[0008] In accordance with another embodiment of the present invention, a tamper-resistant aerator system includes a housing, an aerator cartridge at least partially disposed within the housing, an insert at least partially disposed within the housing, the insert defining at least one removal slot adapted to receive a tool, and a locking ring at least partially disposed within the housing. The locking ring defines at least one removal slot adapted to receive a tool. The locking ring is rotatable with respect to the housing to allow alignment of the at least one removal slot of the locking ring with the at least one removal slot of the insert to form a continuous passageway defined at least partially by a sidewall of the locking ring and at least partially defined by a sidewall of the insert. The tamper-resistant aerator system also includes a tool adapted to be received in the continuous passageway formed by the alignment of the at least one removal slot of the locking ring with the at least one removal slot of the insert and engage the insert.

[0009] In certain configurations, the tamper-resistant aerator also includes a mating engagement between the locking ring and the housing, in which the mating engagement is adapted to securely hold the locking ring within the housing. The mating engagement may include at least one protrusion on an exterior surface of the locking ring and a corresponding

indentation on an interior surface of the housing adapted to receive the protrusion. The protrusion may include a circumferential ring around the exterior surface of the locking ring and the indentation may include a circumferential groove in the interior surface of the housing.

[0010] Optionally, the mating engagement is an interference engagement. In a further configuration, the tool includes a handle and at least one elongated extension. The locking ring may include two slots on opposite sides of a circumference of the locking ring, and the insert may have two slots on opposite sides of a circumference of the insert, and the tool may have two elongated extensions. In a further configuration, an interior surface of the housing includes a protrusion, and an exterior portion of the threaded fitting abuts the protrusion, when the insert is secured within the housing by the protrusion and the locking ring.

BRIEF DESCRIPTION OF THE DRAWINGS

[0011] **FIG. 1** is an exploded perspective view of the components of one embodiment of the aerator.

[0012] **FIG. 2** is a cross-sectional side view of one embodiment of the assembled aerator.

[0013] **FIG. 3** is a front view of a tool of the aerator system.

[0014] **FIG. 4** is a front partial perspective view of the aerator system having a tool engaged therewith in which the removal slots of the locking ring are not aligned with the removal slots of the insert.

[0015] **FIG. 5** is a front partial perspective view of the aerator system having a tool engaged therewith in which the removal slots of the locking ring are aligned with the removal slots of the insert.

DETAILED DESCRIPTION OF THE INVENTION

[0016] As shown in **FIGS. 1** and **2**, one embodiment of a double-acting tamper-resistant aerator **10** includes an external housing **12**. An aerator cartridge **14**, an insert **16**, and a locking ring **18** are at least partially disposed within an inner diameter of the housing **12**. The aerator cartridge **14**, the insert **16**, and the locking ring **18** all have maximum outer diameters that are equal to or less than the inner diameter of the housing **12**.

[0017] The insert **16** is provided with threads **19** that are used to secure the aerator **10** to the faucet. The threads **19** may be on an interior surface **20** of the insert **16** as shown in **FIGS. 1** and **2**, or may be on an exterior surface **21** of the insert **16**. If the threads **19** are on

the interior surface **20** of the insert **16**, as shown in **FIGS. 1** and **2**, the insert **16** may be partially or completely disposed within the housing **12**. If the threads **19** are on the exterior surface **21** of the insert **16**, only a portion of the insert **16** is disposed within the housing **12** and the portion of the insert **16** having the threads **19** is disposed outside of the housing **12**.

[0018] The insert **16** also defines at least one removal slot **22**. The removal slot **22** extends for a portion of or the entire height of a sidewall **24** of the insert **16** and may extend partially or completely through the thickness of the sidewall **24**. In the embodiment shown in **FIGS. 1** and **2**, the insert **16** has two removal slots **22** that extend for a portion of the height of the sidewall **24** and completely through the thickness of the sidewall **24**. If the removal slot **22** extends for the entire height of the sidewall **24**, the removal slot **22** may only extend through a portion of the thickness of the sidewall **24**. When the insert **16** includes a plurality of removal slots **22**, the removal slots **22** may be arranged in any fashion around the circumference of the insert **16**. In the embodiment shown in **FIG. 1**, the two removal slots **22** are arranged on opposite sides of the circumference of the insert **16**.

[0019] The locking ring **18** defines at least one removal slot **28**. The removal slot **28** extends for the entire height of a sidewall **30** of the locking ring **18** and extends partially through the thickness of the sidewall **30**, although other suitable configurations for the removal slot **28** may be utilized. In the embodiment shown in **FIGS. 1** and **2**, the locking ring **18** has two removal slots **28**. When the locking ring **18** includes a plurality of removal slots **28**, the removal slots **28** may be arranged in any fashion around the circumference of the locking ring **18**. In the embodiment shown in **FIG. 1**, the two removal slots **28** are arranged on opposite sides of the circumference of the locking ring **18**.

[0020] The removal slots **28** of the locking ring **18** are configured to correspond to the removal slots **22** of the insert **16** such that proper alignment of the locking ring **18** and the insert **16** cause the removal slots **22**, **28** to form a continuous passageway defined by the sidewall **30** of the locking ring **18** and at least partially defined by the sidewall **24** of the insert **16**.

[0021] The locking ring **18** is matingly engaged with the housing **12** such that it is free to rotate within the housing **12** allowing the removal slots **22**, **28** to be aligned to form a passageway as described above. Such mating engagement may take any suitable form as long as the locking ring **18** is securely fastened within the housing **12** yet is free to rotate with respect to the housing **12**. Such an engagement includes, but is not limited to, at least one protrusion **32** on an exterior surface **34** of the locking ring **18** and a corresponding indentation **38** on an interior surface **40** of the housing **12** adapted to receive the protrusion **32**. In the

embodiment shown in **FIGS. 1** and **2**, the protrusion **32** takes the form of a circumferential ring on the exterior surface **34** of the locking ring **18** and the indentation **38** takes the form of a circumferential groove in the interior surface **40** of the housing **12**. The protrusion **32** is interference or snap-fit into the indentation **38**. This interference fit has sufficient play to allow the locking ring **18** to rotate with respect to the housing **12** while securely hold the locking ring **18** within the housing **12**.

[0022] The housing **12** may also include a protrusion **42** extending from its interior surface **40**. A portion **44** of the insert **16** is configured to abut the protrusion **42** in the housing **12** when the locking ring **18** is matingly engaged with the housing **12**. Thus, the insert **16** is securely held within the housing **12** by the protrusion **42** and a top surface **46** of the locking ring **18**. In **FIGS. 1** and **2**, the protrusion **42** is a ledge that extends circumferentially around the interior surface **40** of the housing **12** and the insert **16** has a corresponding portion comprising a circumferential ledge extending around its exterior surface **21**. Alternatively, the protrusion **42** could engage a top surface **48** of the insert **16**. This engagement may allow for rotation of the insert **16** with respect to the housing **12**.

[0023] The aerator **10** may also include a mating engagement between the aerator cartridge **14** and the insert **16** adapted to secure the aerator cartridge **14** within the housing **12**. The mating engagement may take the form of an extension **50** on the insert **16** projecting into the inner diameter of the insert **16** and an extension **52** projecting outwardly from an exterior surface **54** of the aerator cartridge **14**. In the embodiment shown in **FIG. 2**, the extension **50** on the insert **16** takes the form of a ledge at a bottom **56** of the insert **16** and the extension **52** on the aerator cartridge **14** takes the form of a ledge at a top **58** of the aerator cartridge **14**. The extensions **50**, **52** cooperate such that the aerator cartridge **14** is held within the housing **12** by the cooperation of the ledges **50**, **52** and the end of the faucet when the insert **16** is attached to the faucet.

[0024] A bottom portion **59** of the sidewall **24** of the insert **16** has a thickness equal to the thickness of the sidewall **30** of the locking ring **18** and the aerator cartridge **14** has an outer diameter corresponding to the inner diameter of the locking ring **18**. This assures that the entirety of the water passing into the aerator **10** from the faucet passes through and not around the aerator cartridge **14**.

[0025] A rubber gasket **60** may also be provided on top **58** of the aerator cartridge **14** such that the gasket **60** provides a tight fit between the top **58** of the aerator cartridge **14** and the faucet when the aerator **10** is connected to the faucet.

[0026] To assemble the aerator **10**, the insert **16** is placed into the housing **12** from the bottom. A portion **44** of the insert **16** abuts the protrusion **42** on the interior surface **40** of the housing **12**. Next, the locking ring **18** is inserted into the housing **12** from the bottom. As described above, there is an interference between the locking ring **18** and the housing **12** to ensure the locking ring **18** is securely held within the housing **12** after assembly. Once the locking ring **18** has been inserted far enough into the housing **12**, the protrusion **32** on the exterior surface **34** of the locking ring **18** engages the indentation **38** holding the locking ring **18** securely within the housing **12** yet allowing it to spin freely with respect to the housing **12**. Finally, the aerator cartridge **14** is inserted into the insert **16** from the top of the aerator **10**.

[0027] The installation and the removal of the aerator **10** from the faucet is accomplished using a tool **62**, such as a tool, adapted to be inserted in the passageway(s) created by the alignment of the removal slots **22**, **28** of the locking ring **18** and the insert **16**. The tool **62** has a handle **64** and at least one elongated extension **66** and may have a number of extensions **66**, with the number of extensions **66** corresponding to the number of passageways created by alignment of the locking ring **18** and the insert **16**. One embodiment of the tool **62** is shown in **FIG. 3**. This embodiment has two extensions **66** corresponding to the two passageways created by alignment of the locking ring **18** and the insert **16** shown in **FIG. 1**. The extensions **66** should have sufficient length to pass through the removal slots **28** in the locking ring **18** and into the removal slots **22** of the insert **16**. The extensions **66** are of suitable size and shape to engage the insert **16**. Application of torque to the handle **64** of the tool **62** is transferred from a proximal end **68** of the extensions **66** to the insert **16** allowing the aerator **10** to be screwed into the end of the faucet via the threads **19** of the insert **16**.

[0028] In use, the extensions **66** on the tool **62** are placed into the removal slots **28** of the locking ring **18**. As can be seen in **FIG. 4**, only a portion of the length of the extensions **66** are received by the removal slots **28** of the locking ring **18**. The tool **62** is then turned until the removal slots **28** of the locking ring **18** are aligned with the removal slots **22** of the insert **16**. As shown in **FIG. 5**, upon alignment, the extensions **66** are further received into the aerator **10** and seated in the removal slots **22** of the insert **16**. Upon further rotation of the tool **62**, the insert **16** is rotated allowing the aerator **10** to be screwed into or unscrewed from the faucet via the threads **19**.

[0029] The embodiments of the aerator and aerator system as described herein provide two measures to resist removal of the aerator **10** from the faucet by unauthorized persons. Only when removal slots **22**, **28** of the locking ring **18** and the insert **16** are aligned can the tool **62** slide fully into the aerator **10** to engage the insert **16** and allow the aerator **10** to be removed

from the faucet. A person desiring to tamper with the aerator therefore needs to have a long enough makeshift tool to accomplish removal which makes removal and tampering much more cumbersome. Also, a person desiring to tamper with the aerator **10** will need to have the knowledge that, unlike typical tamper-resistant aerators, the engagement point between the tool **62** and the insert **16** is significantly farther inside the housing **12**. Further, a person desiring to tamper with the aerator **10** will need to realize that in order to access the removal slots **22** in the insert **16**, the removal slots **28** of the locking ring **18** need to be aligned with the removal slots **22** of the insert **16**. All of this additional necessary knowledge and the additional work to find an appropriate makeshift tool further deter tampering with the aerator **10**.

[0030] Although the invention has been described in detail for the purpose of illustration based on what is currently considered to be the most practical and preferred embodiments, it is to be understood that such detail is solely for that purpose and that the invention is not limited to the disclosed embodiments, but, on the contrary, is intended to cover modifications and equivalent arrangements that are within the spirit and scope of this specification. For example, it is to be understood that the present invention contemplates that, to the extent possible, one or more features of any embodiment can be combined with one or more features of any other embodiment.

THE INVENTION CLAIMED IS

1. A tamper-resistant aerator comprising:
a housing;
an aerator at least partially disposed within the housing;
an insert engaged with a portion of the housing, the insert defining at least one insert removal slot adapted to receive at least a portion of a tool; and
a locking ring at least partially disposed within the housing, the locking ring defining at least one locking ring removal slot extending substantially the entire height of the locking ring and adapted to receive at least a portion of the tool, the locking ring rotatable relative to the housing,
wherein the locking ring is rotatable to align the at least one insert removal slot with the at least one locking ring removal slot.
2. The tamper-resistant aerator of claim 1, further comprising a mating engagement between the locking ring and the housing, wherein the mating engagement is adapted to secure the locking ring within the housing.
3. The tamper-resistant aerator of claim 2, wherein the mating engagement comprises at least one protrusion on an exterior surface of the locking ring and a corresponding indentation on an interior surface of the housing adapted to receive the at least one protrusion.
4. The tamper-resistant aerator of claim 3, wherein the at least one protrusion is a circumferential ring around the exterior surface of the locking ring and the indentation is a circumferential groove in the interior surface of the housing.
5. The tamper-resistant aerator of claim 2 wherein the mating engagement is an interference engagement.
6. The tamper-resistant aerator of claim 1, wherein alignment of the at least one locking ring removal slot with the at least one insert removal slot forms a continuous passageway through a sidewall of the locking ring and at least partially through a sidewall of the insert.

7. The tamper-resistant aerator of claim 1, wherein the locking ring has two slots disposed on opposite sides of a circumference of the locking ring, and wherein the insert has two slots disposed on opposite sides of a circumference of the insert.

8. The tamper-resistant aerator of claim 1, wherein an interior surface of the housing comprises a protrusion, and an exterior portion of the insert abuts the protrusion when the insert is secured within the housing by the protrusion and the locking ring.

9. The tamper-resistant aerator of claim 1, wherein the aerator comprises an aerator cartridge, the aerator cartridge and the insert engage each other to secure the aerator cartridge within the housing.

10. The tamper-resistant aerator of claim 9, wherein the insert comprises an extension projecting into an inner diameter of the insert, and the aerator cartridge comprising an extension projecting outwardly from an exterior surface of the aerator cartridge that is configured to engage the extension of the insert.

11. The tamper-resistant aerator of claim 10, wherein the extension on the insert and the extension on the aerator form a ledge.

12. The tamper-resistant aerator of claim 9, further comprising a rubber gasket disposed within the insert and resting on a top surface of the aerator cartridge.

13. A tamper-resistant aerator system comprising:
a housing;
an aerator cartridge at least partially disposed within the housing;
an insert at least partially disposed within the housing, the insert defining at least one insert removal slot adapted to receive a tool; and
a locking ring at least partially disposed within the housing, the locking ring defining at least one locking ring removal slot extending substantially the entire height of the locking ring and adapted to receive a tool,
wherein the locking ring is rotatable with respect to the housing to allow alignment of the at least one locking ring removal slot with the at least one insert

removal slot to form a continuous passageway defined at least partially by a sidewall of the locking ring and at least partially defined by a sidewall of the insert; and

a tool adapted to be received in the continuous passageway formed by the alignment of the at least one locking ring removal slot with the at least one insert removal slot and engage the insert.

14. The tamper-resistant aerator system of claim 13, further comprising a mating engagement between the locking ring and the housing, wherein the mating engagement is adapted to securely hold the locking ring within the housing.

15. The tamper-resistant aerator system of claim 14, wherein the mating engagement comprises at least one protrusion on an exterior surface of the locking ring and a corresponding indentation on an interior surface of the housing adapted to receive the at least one protrusion.

16. The tamper-resistant aerator system of claim 15, wherein the at least one protrusion comprises a circumferential ring around the exterior surface of the locking ring and the indentation comprises a circumferential groove in the interior surface of the housing.

17. The tamper-resistant aerator system of claim 14, wherein the mating engagement is an interference engagement.

18. The tamper-resistant aerator system of claim 13, wherein the tool comprises a handle and at least one elongated extension.

19. The tamper-resistant aerator system of claim 18, wherein the locking ring has two slots disposed on opposite sides of a circumference of the locking ring, the insert has two slots disposed on opposite sides of a circumference of the insert, and the tool has two elongated extensions.

20. The tamper-resistant aerator system of claim 13, wherein an interior surface of the housing comprises a housing protrusion, and an exterior portion of the insert

abuts the housing protrusion when the insert is secured within the housing by the housing protrusion and the locking ring.

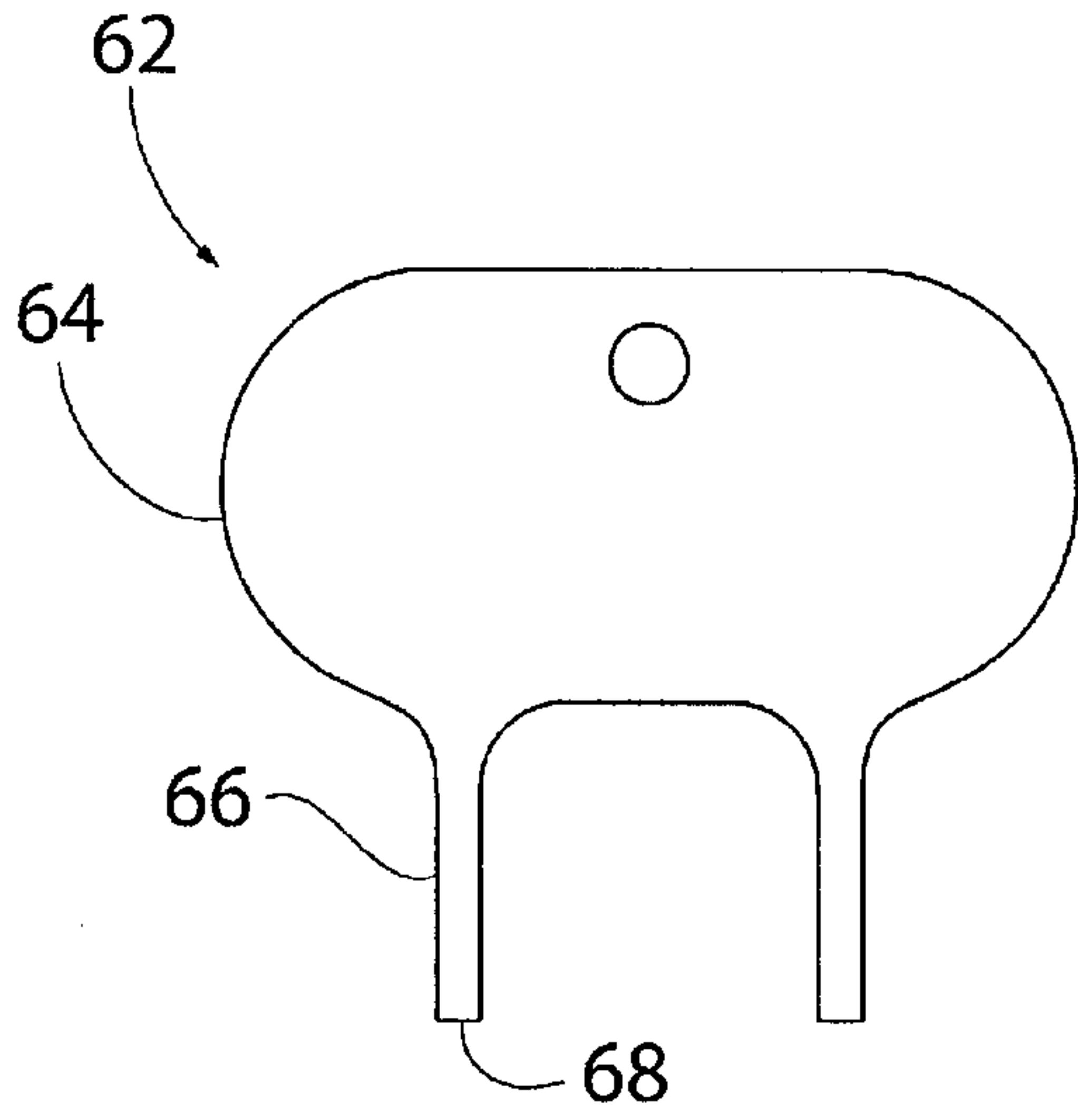

FIG. 3

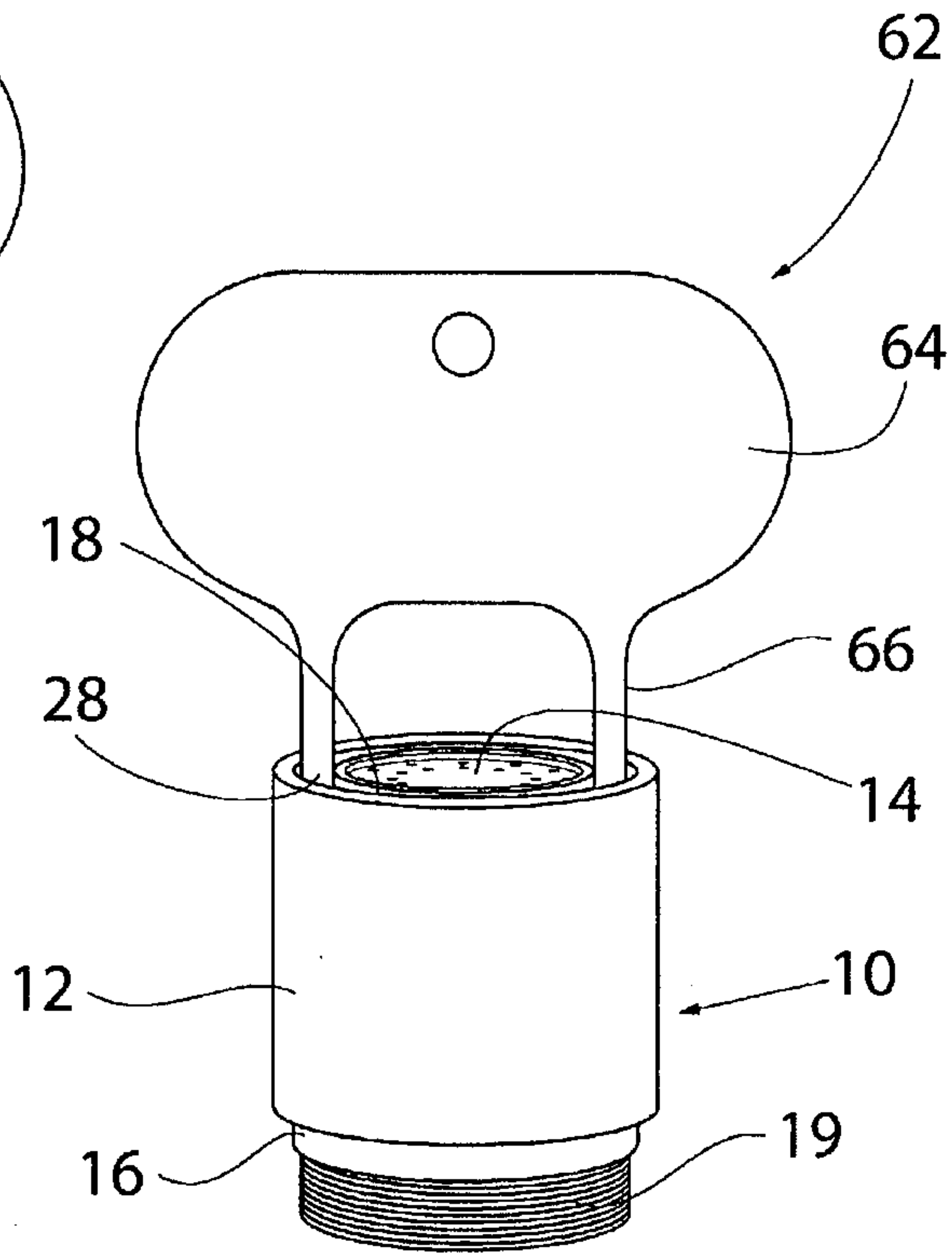

FIG. 4

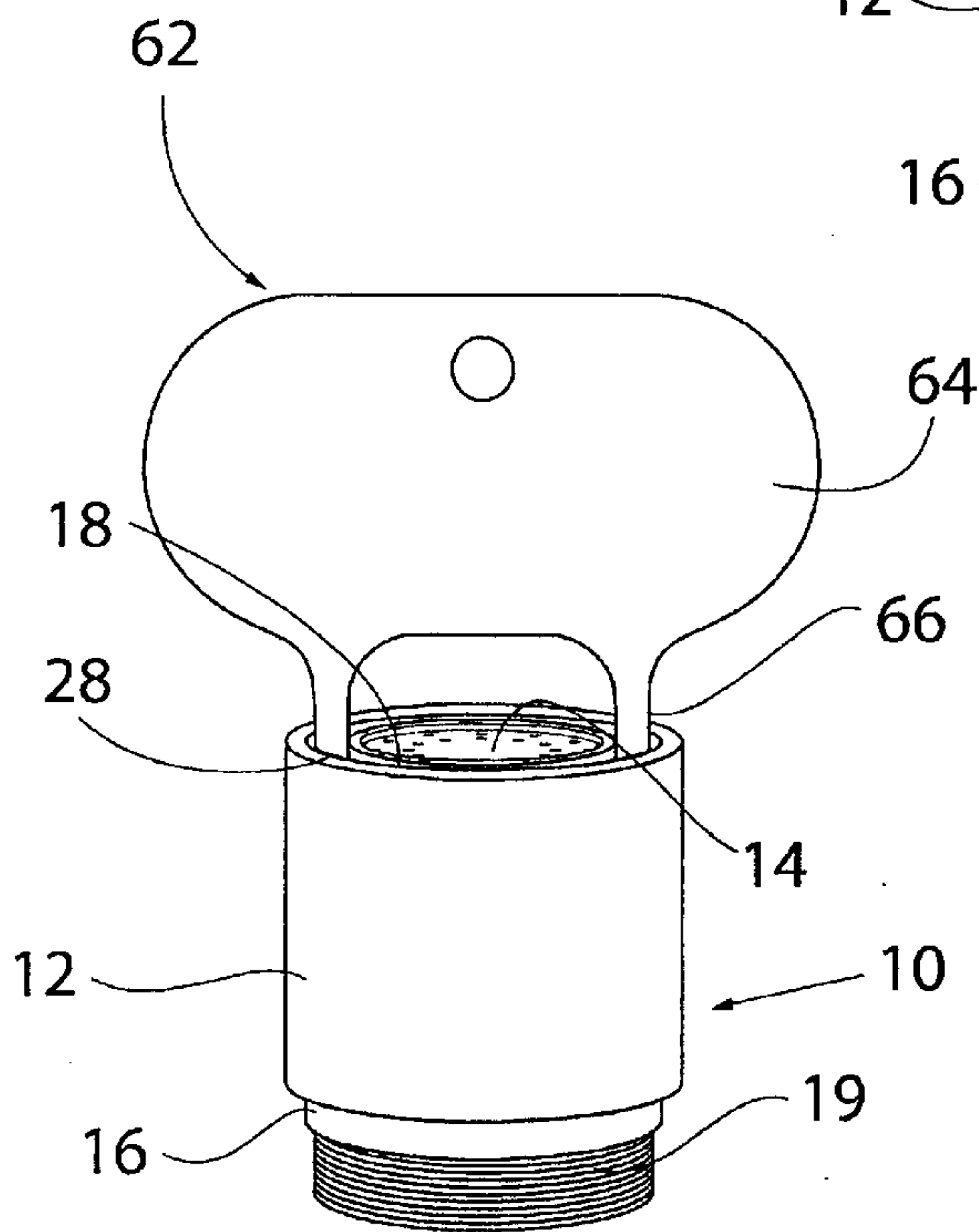

FIG. 5

