

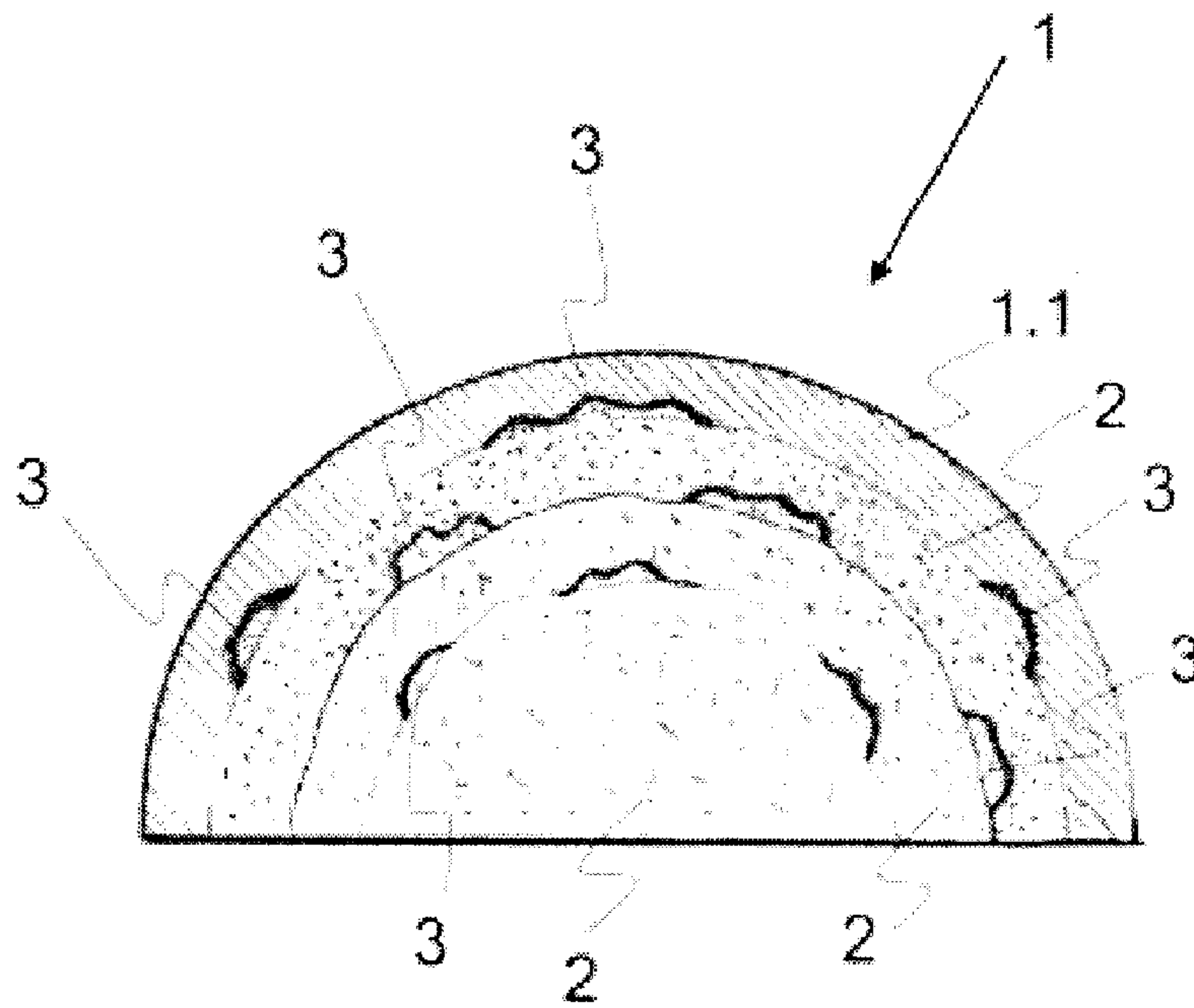

(22) Date de dépôt/Filing Date: 2009/12/15  
 (41) Mise à la disp. pub./Open to Public Insp.: 2011/01/27  
 (45) Date de délivrance/Issue Date: 2016/02/16  
 (62) Demande originale/Original Application: 2 768 696  
 (30) Priorité/Priority: 2009/07/23 (TR2009/05721)

(51) Cl.Int./Int.Cl. *B44C 3/00* (2006.01),  
*B44F 7/00* (2006.01)  
 (72) Inventeur/Inventor:  
BICAKCI, SEVAN, TR  
 (73) Propriétaire/Owner:  
BICAKCI, SEVAN, TR  
 (74) Agent: RIDOUT & MAYBEE LLP

(54) Titre : PROCÉDE DE CREATION D'UNE IMAGE TRIDIMENSIONNELLE A L'INTERIEUR D'UNE PIERRE  
 (54) Title: METHOD TO CREATE THREE DIMENSIONAL IMAGE INSIDE STONE



(57) Abrégé/Abstract:

The invention is a method for creation of three-dimensional image in the transparent stone (1) and it comprises process steps of carving the inside of the said transparent stone (1), forming space therein and providing an outer shell (1.1), making at least one

(57) **Abrégé(suite)/Abstract(continued):**

designing on the surface of the said outer shell (1.1) facing inside, making at least one transparent filling layer (2) on the surface of the said outer shell (1.1) facing inward, making at least one designing on the surface of the said filling layer (2) facing inward, repeating one under the other the designing and filling layer (2) designing as per the design on the surface of the said filling layer (2) facing inward, connecting a at least one three- dimensional object (5) to the inward facing surface of the filling layer (2) at the very bottom, and closing the lower part of the stone (1).

**ABSTRACT**

The invention is a method for creation of three-dimensional image in the transparent stone (1) and it comprises process steps of carving the inside of the said transparent stone (1), forming space therein and providing an outer shell (1.1), making at least one designing on the surface of the said outer shell (1.1) facing inside, making at least one transparent filling layer (2) on the surface of the said outer shell (1.1) facing inward, making at least one designing on the surface of the said filling layer (2) facing inward, repeating one under the other the designing and filling layer (2) designing as per the design on the surface of the said filling layer (2) facing inward, connecting a at least one three-dimensional object (5) to the inward facing surface of the filling layer (2) at the very bottom, and closing the lower part of the stone (1).

## METHOD TO CREATE THREE DIMENSIONAL IMAGE INSIDE STONE

This application is a divisional of Canadian patent application Serial No. 2,768,696  
5 filed internationally on December 15, 2009 and entered nationally on January 19,  
2012.

### **The Related Art**

10 The invention relates to a method for creation of image inside transparent stones.

The invention particularly relates to a method for creation of various figures in  
three dimensional in inner parts of precious stones and/or accessories used in  
jewellery.

15

### **Background of the Related Art**

Processing embodiments inside and on various stones have been realized in  
order to create images from different designs, pictures and figures in inner parts of  
20 transparent stones. The said processing is made by means of designs and  
colouring coating made on the stone in the simplest way. Another embodiment  
relates to processes conducted inside transparent stones. Processing the inner  
part of the stone to give image outside is another applied method. The said  
method has some problems in terms of application. Cutting inner part of the stone  
25 brings the risk of damaging the stone. There are always risks such as breaking or  
weakening of the stone during removal of inner part of the stone. Processing the  
inner part of the stone is not easy by use of modern processing members either.  
One of the said applications is disclosed under patent application numbered  
TR200607117 entitled "process for sculpture processing in stone". The said  
30 application discloses a process containing carving the inner part of the stone and  
removal of it by use of special methods and filling the space by filling material after  
painting thereof. The steps of process consisting of 3 steps obtaining a space by  
means of eroding the lower part of the jewellery stone by use of mechanical

method as required by the desired architecture, leaving the eroded and spaced shape as it is in the simple manner or painting in colours by appropriate paint, and filling the space areas of the stone of which painting has been completed, by use of a filling material of hardness close to hardness of the stone.

5

The said art and applications are for forming a two dimensional image in or on the stone. The known technical applications do not allow to create three dimensional image on or in the stone. Upon development of imaging technologies, capability to create three dimensional images has become alternative to two dimensional images not having depth. Creating three-dimensional image on or in the stone enables giving an effect much closer to the real effect of accessories and is one of the factors determining the preference of consumer. In order to create three-dimensional image and depth, gradual carving in the stone outward is conducted and thus 3-dimensional image can be created. Although it is no so close to the real appearance, the depth can be provided. Even it is likely to create this image for one single member, when images of objects independent of each other are, the gradual carving remains inadequate.

In order to eliminate the said disadvantages, it is aimed to produce jewellery accessories having three-dimensional.

20

### **Purpose of the Invention**

From the current status of the related art, the purpose of the invention is to eliminate the existing disadvantages by means of improvements made in manufacturing methods used for creation of various three-dimensional figures in inner parts of the precious stones and/or accessories used particularly in jewellery.

Another purpose of the invention is to disclose a stone processing method for image details of real like image which are connected to the desired part of any jewellery and decorative properties such as ring, bracelet, necklace, ear-rings, brooch and cuff links. A further purpose of the invention is to enhance visual

30

depth. Another purpose of the invention is to provide visual effect of figures, shapes, pictures, designs closer to real.

Another purpose of the invention is to provide complex figures having different  
5 details. A further purpose of the invention is to provide coloured and non-coloured images. Thus various alternatives in jewellery have been provided. Therefore, process of figures not intended to be applied in jewellery accessories has been provided. Use of foreign material has been prevented by means of providing design on the stone in this way. Thus, decrease in value of jewellery accessories  
10 has been prevented.

In order to achieve the said purposes, it is a method for creation of three-dimensional image in transparent stones used as jewellery and accessories in particularly jewellery and precious stones sector.

15

A preferred embodiment of the invention is a method for creation of three-dimensional image in the said transparent stone and it comprises process steps of curving the inside of the said transparent stone, forming space therein and providing an outer shell, making at least one designing on the surface of the said  
20 outer shell facing inside, making at least one transparent fill layer on the surface of the said outer shell facing inward, making at least one designing on the surface of the said filling layer facing inward, repeating one under the other the designing and filling layer designing as per the design on the surface of the said filling layer facing inward, connecting a at least one three-dimensional object to the inward  
25 facing surface of the filling layer at the very bottom, and closing the lower part of the stone.

### **Description of Figures**

Figure -1a ; Is a general view of an illustrative stone with processed inner side of the stone.

Figure -1b ; Is a section view of the carved form of the stone in illustrative embodiment shown in Figure 1a.

- 4 -

- Figure -1c ; Is a section view of the carved form of the stone and covered with a layer in illustrative embodiment shown in Figure 1b.
- Figure -1d ; Is a section view of the form of stone comprising processed layers of the inner part in illustrative embodiment shown in Figure 1c.
- Figure -2a ; Is a general view of the stone and three-dimensional object connected thereto in illustrative embodiment shown in Figure 1a.
- Figure -2b ; Is a sectional view of the stone with space therein and three-dimensional object therein in illustrative embodiment shown in Figure 1b.
- Figure -2c ; Is a sectional view of filling and three-dimensional object applied to the stone with space in illustrative embodiment shown in Figure 2b.
- Figure -2d ; Is a sectional view of three-dimensional object applied to the stone with inside filling and processed in illustrative embodiment shown in Figure 1c.
- Figure -2e ; Is a sectional view of three-dimensional object with filling in outer surface and processed and connected to the stone with inside filling and processed in illustrative embodiment shown in Figure 1d and 1e.
- Figure -2f ; Is a sectional view of three-dimensional object with filling in inner surface and processed and connected to the stone with inside filling and processed in illustrative embodiment shown in Figure 1d and 1e.

### Reference Numbers

1	Stone	5	Three-dimensional object
1.1	Outer shell	5.1	Space
2	Filling layer	5.2	Filling inner figure
3	Engraving	5.3	Filling outer figure
4	Relief		

### Detailed Description of the Invention

The application shown in figures of the invention relates to a manufacturing method used for creation of various figures in three dimensional in inner parts of precious stones and/or accessories used in jewellery.

The manufacturing processes of the method to form three-dimensional image inside the transparent stone (1) shown in Figures -1a,1b,1c and 1d are as follows. The manufacturing process comprises process steps of carving the inside of the transparent stone (1), forming space therein and providing an outer shell (1.1), making at least one designing on the surface of the said outer shell (1.1) facing inside, making at least one transparent filling layer (2) on the surface of the said outer shell (1.1) facing inward, making at least one designing on the surface of the said filling layer (2) facing inward, repeating one under the other the designing and filling layer (2) designing as per the design on the surface of the said filling layer (2) facing inward, connecting one three-dimensional object (5) to the inward facing surface of the filling layer (2) at the very bottom, and closing the lower part of the stone (1) to complete the manufacturing. The three-dimensional object (5) applied to inner part of the space (5.1) can be provided in the convenient different colour and image designs as per the stone (1).

The designing process is an engraving (3) formed by means of carving on the inward facing surface of the outer shell (1.1) (Figure 1c). The designing process is a relief (4) formed by means of embossing on the inward facing surface of the outer shell (1.1) Figure 1c).

The designing process is an engraving (3) formed by means of carving on the inward facing surface of the filling layer (2). The designing process is a relief (4) formed by means of embossing on the inward facing surface of the filling layer (2). Relief (4) is the painting layer forming thickness and colour.

Figure 2a and Figure 2b show a different manufacturing method wherein three-dimensional object (5) of three dimensional image has been provided in the stone (1).

5 The transparent stone (1) shown in Figures-2a, 2b, 2c and 2d, is formed by carving of the inner side thereof, forming space and leaving an outer shell (1.1), making a transparent filling layer (2) on the inner facing surface of the outer shell (1.1) and connection of a three-dimensional object (5) onto inward facing surface of the filling layer (2). The three-dimensional object (5) is a three-dimensional  
10 figure.

The three-dimensional object (5) shown in Figures 2d, 2e and 2f can complete the figures located in the stone (1) upon subjecting it to various processes. The process steps of the method shown in Figures 2b and 2f comprises carving of the  
15 inner side of the three-dimensional object (5), forming space (5.1), making a filling inner figure (5.2) on the inner surface of the three-dimensional object (5), making the transparent filling layer (2) on the inner surface of the three-dimensional object (5) and connection of three-dimensional object (5) with processed inner part to the inner surface of the outer shell (1.1). When forming figure in the inner part of the  
20 three-dimensional object (5), three-dimensional object (5) is designed from transparent material. The space (5.1) is reinforced by means of a filling material and lower surface of the stone (1) is covered. The filling applied to inner part of the space (5.1) can be provided in the convenient different colour and image designs as per the stone (1).

25

The three-dimensional object (5) shown in Figures 2a and 2e can complete the figures located in the stone (1) upon subjecting it to various processes. The sequence of process steps comprises respectively making a filling outer figure (5.3) on outer surface of the three-dimensional object (5), making a transparent  
30 filling layer (2) on the outer surface of the three-dimensional object (5), connection of the three-dimensional object (5) covered on the inner surface of the outer shell (1.1).

- 7 -

A method for forming a three-dimensional image inside a transparent stone (1) according to the description herein and the method is characterized in that the filling layer (2) is a transparent material which can be processed to create depth.

5 The steps of the method shown in Figures-1a, 1b, 1c and 1d.

After the stone is provided with a space with a desired depth from lower part of the stone (Figure 1b), relief is carved in the formed space onto inner walls. After painting the carved figures and coating agent is applied, new engraving is made as the second layer on this coating and then painted. A 3-dimensional depth is  
10 provided to the architecture and engraving inside the stone by applying the processes several times.

The method shown in Figures-1a, 1b, 1c and 1d comprises 3 steps.

At step 1, the jewellery is emptied by method of mechanical eroding at the  
15 convenient size and depth from lower part of the stone (Figures1-b, 2b).

At step 2, a desired object (three-dimensional object (5)) is located inside the stone (Figures 2d, 2e, 2f).

At step 3, a transparent filling material (filling layer (2)) appropriate to the colour and features of the stone (1) is filled in the space remaining after location of object  
20 (three-dimensional object (5)), (Figure 2c).

Process steps comprises process of the stone (1), carving of the inside as convenient for the figure, painting the inside of the carving appropriate to the figure, and filling the carving in a manner supporting the carving.

25

The basic application in forming three-dimensional image is to create original image of any figure. A negative figure is formed inside the stone (1). A negative eroding is made in the inner surface of the stone (1). Thus space is provided by eroding. The eroding is preferably performed by hand because of sensitivity.

30 Thus the carving is realized. The limits of the inner volume are removed as much as possible and is used. The inside of the stone (1) is emptied in a manner the outer shell (1.1) remains.

In an illustrative application of the invention,

By means of carving from one edge inward of a precious and/or side precious stone (1) for instance, amethyst colour quartz, tourmalines, citrine, topaz  
5 aquamarines etc. by use of digging carving tools, the inside thereof is removed in a manner only one thin outer shell (1.1) remains on other edges. After completion of removing the inside by carving, any portrait, scene, religious symbol, word, devil eye symbol, shape, figure, pattern, picture etc. is drawn on the inner surfaces of the stone turned into a lantern by use of any paint and brushes. The  
10 painted picture forms the top coating of the work performed inside the stone. Then the inner surface of the outer shell (1.1) is coloured by dye. A desired image is provided to the inner part by engraving (3) or relief (4). The relief (4) can be provided by painting (Figure 1c). Depth can be provided by applying filling layer (2) as required by the figure details. Filling layers (2) are applied in an order.  
15 Integrity is provided by performing engraving (3) on the filling layers (2) or colouring layers. Processing different images and painting (relief (4)) on each filling layer (2) is carried out. Gradual image is provided by means of creating image on each filling layer (2). The filling layers (2) connected to each other are displayed by various shading (Figure-1d).

20

Among examples of figures made are birds flying over each other, flying butterflies, birds on a building and flying birds over a building, a home seen through an open window, imam at reading desk in a mosque, home view through an open window or dragon which can be imaged easily. It can be said that a  
25 kind of pictures over each other is made by means of the created images.

By filling the space remaining in the inner part of the stone (1) of which inner part is processed and shaped with layers, the process is completed. Support is provided by mine and a similar stone as three-dimensional object (5) (Figure-2b).

30

The stone (1) to be processed can be transparent or opaque/mat colour as required by the design. The stone (1) material can be different mineral stone,

glass. The process can be made to any types of stone (1). Carving technique depending on type of stone can be made by painting and filling technique.

In a different application, the figure can be located not in the form of a picture but  
5 as a processed material in the stone (1) such as a three-dimensional object (5) without curving. In other words, the figure can be located to lower base of the transparent stone (1) by means of a three-dimensional object (5). Or it can be supplemented with layer inside the stone (1) by processing a part of the figure on the three-dimensional object (5). The three-dimensional object (5) can also be a  
10 precious stone. The inner surface of the three-dimensional object (5) can also be processed.

Shaped stone (1) is inserted or fixed into jewellery and used. The products with coloured or non-coloured inside negative sculpture and decorated with stones  
15 formed according to the above description is attached to desired part of any jewellery and decorative belongings such as rings, bracelet, necklace, ear-rings, broche, cuff links by use of any fixing and adhering processes.

The invention cannot be limited to the illustrative embodiments given under this  
20 section. Alternative embodiments that can be developed by persons skilled in the related art on basis of basic factors covered under scope of protections indicated under claims shall mean violation of the invention.

**WHAT IS CLAIMED IS:**

1. A method to form a three-dimensional image inside a transparent stone (1) characterized in that the method comprises process steps of:
  - forming at least one space (5.1) by carving an inner side of a three-dimensional object (5),
  - making at least one filling inner figure (5.2) onto an inward facing surface of the said three dimensional object (5),
  - making at least one transparent filling layer (2) onto the inward facing surface of the said three dimensional object (5),
  - connecting the three-dimensional object (5) having processed inner side onto an inward facing surface of an outer shell (1.1) which is formed by carving from an inner side of the said transparent stone (1)
  
2. A method to form a three-dimensional image inside a transparent stone (1) characterized in that the method comprises process steps of
  - making at least one filling outer figure (5.3) onto an outward facing surface of a three dimensional object (5),
  - making at least one transparent filling layer (2) onto the outward facing surface of the said three dimensional object (5),
  - connecting the said coated three-dimensional object (5) onto an inward facing surface of an outer shell (1.1) which is formed by carving from an inner side of the said transparent stone (1).

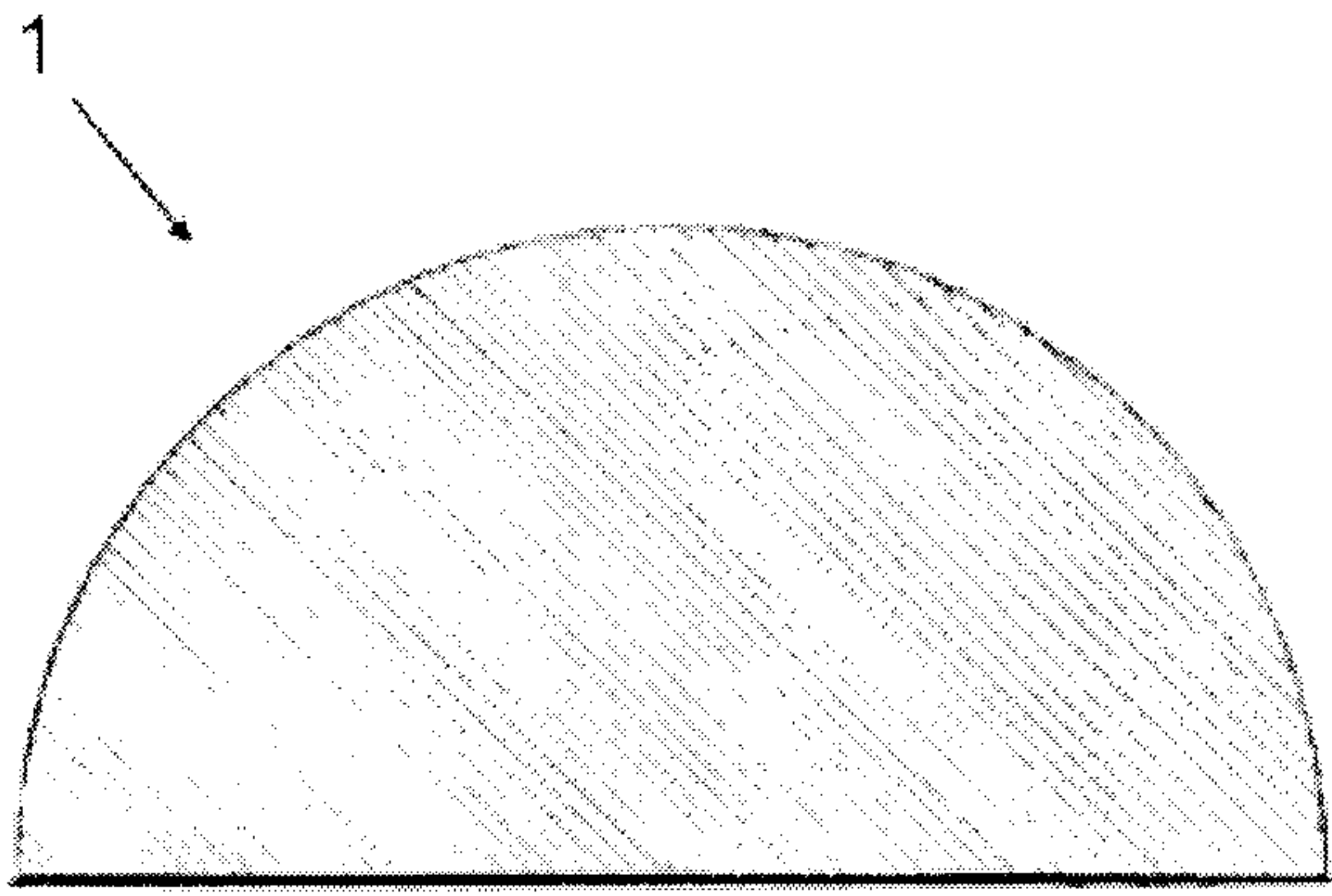

Figure - 1a

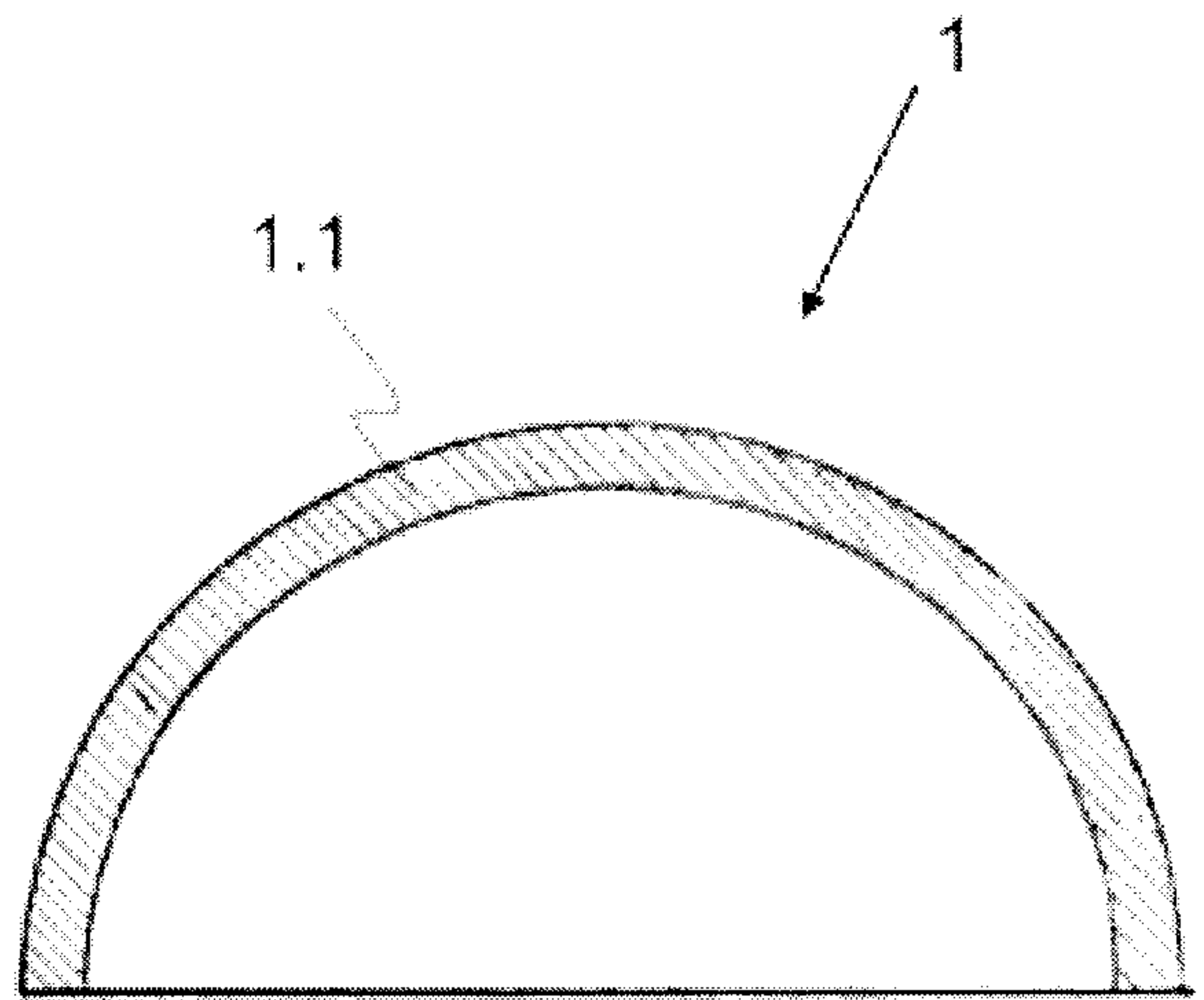

Figure - 1b

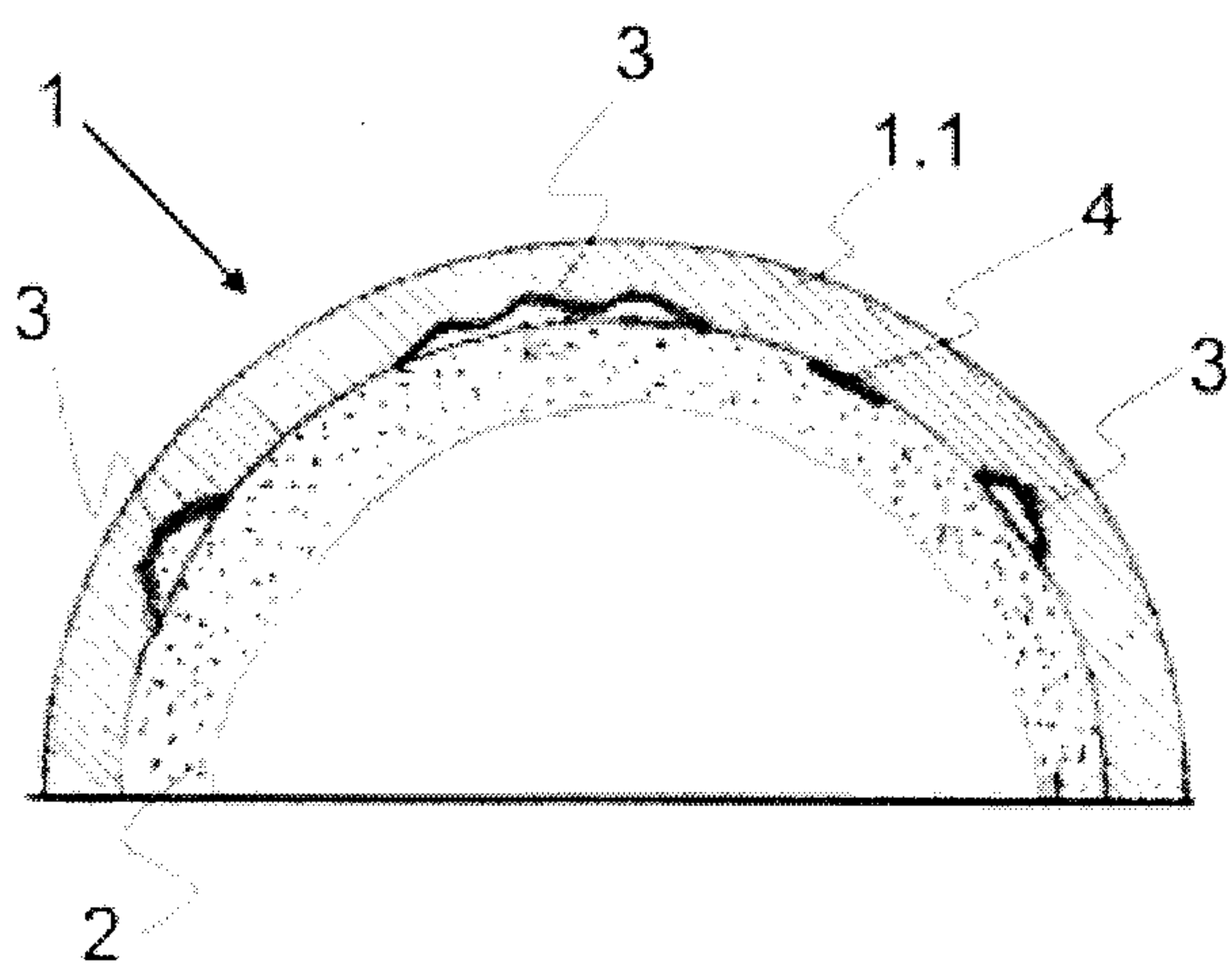

Figure - 1c

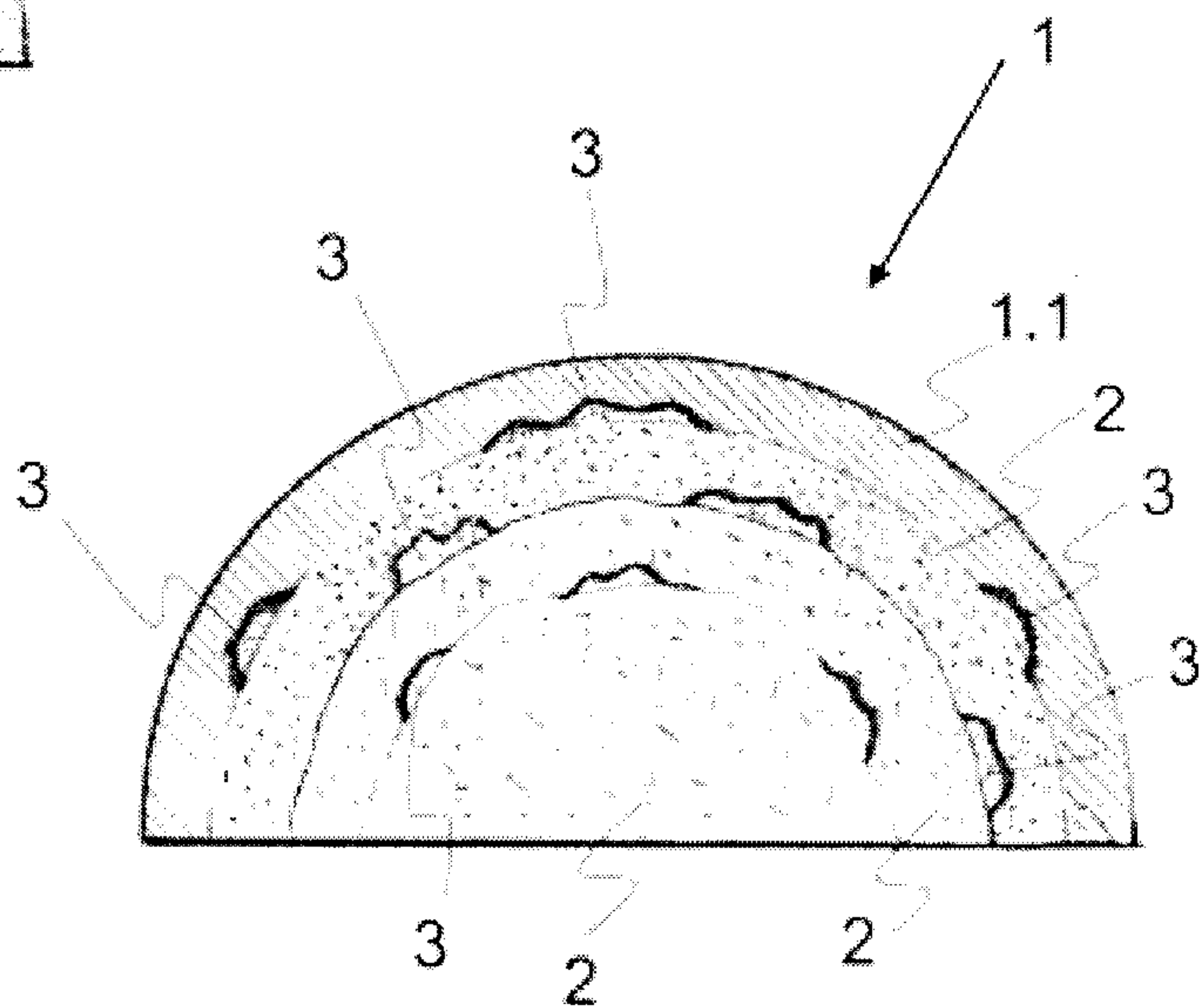

Figure - 1d

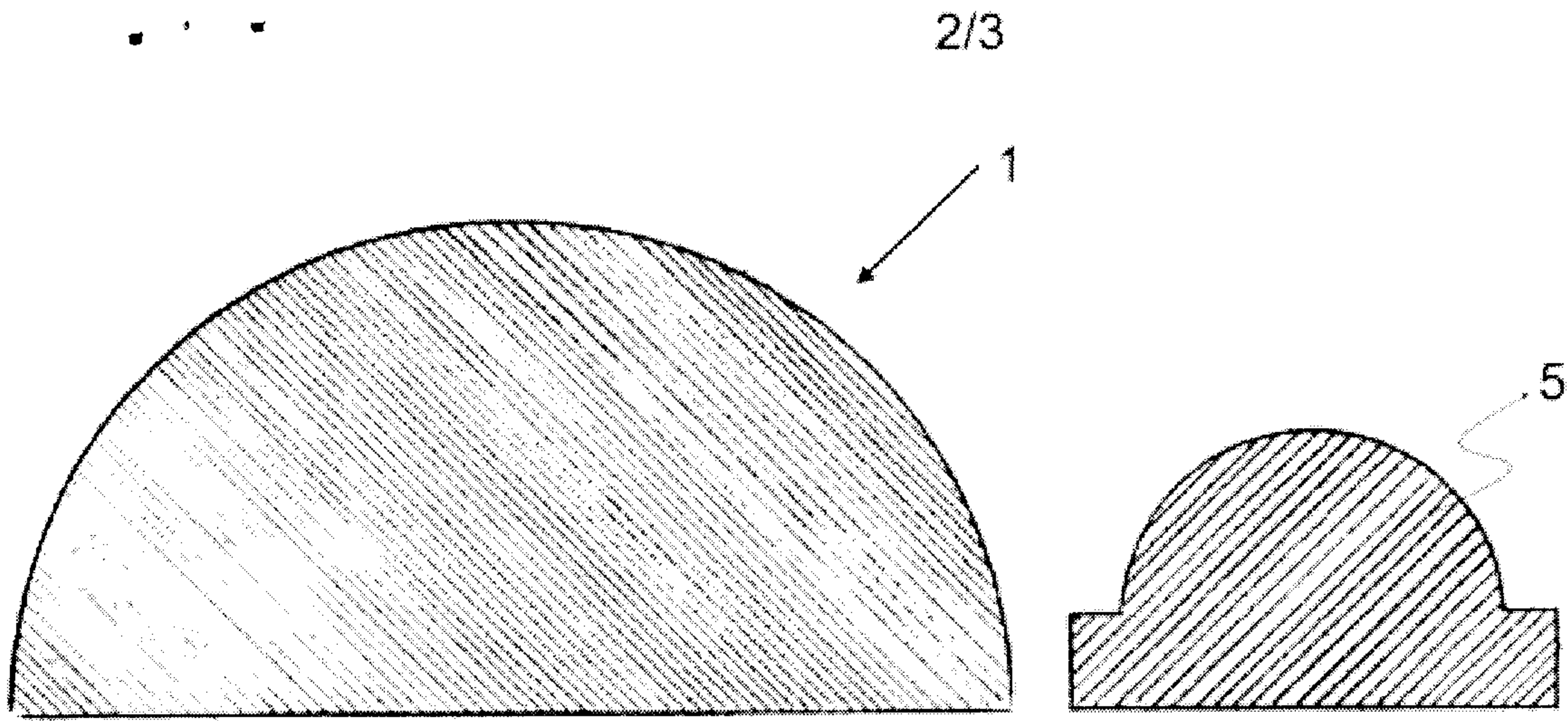

Figure -2a

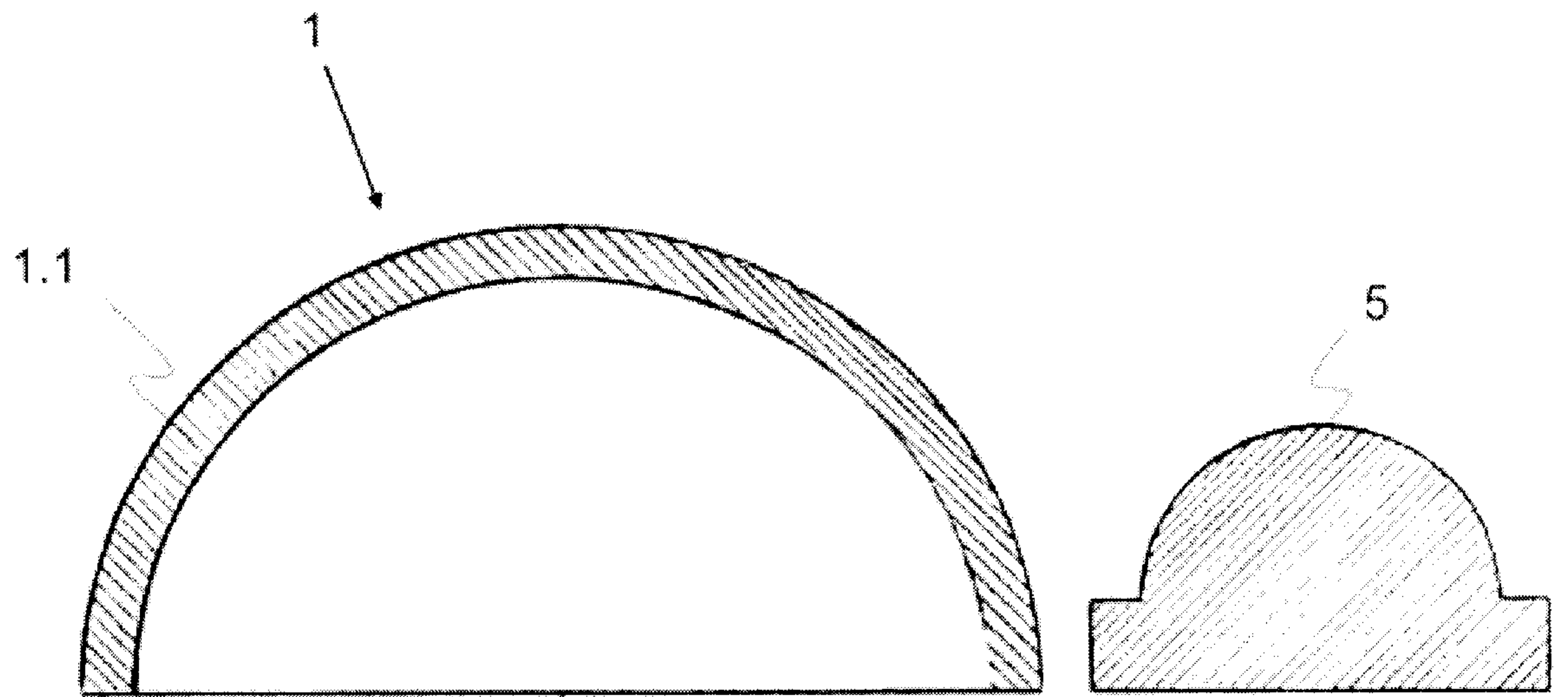

Figure - 2b

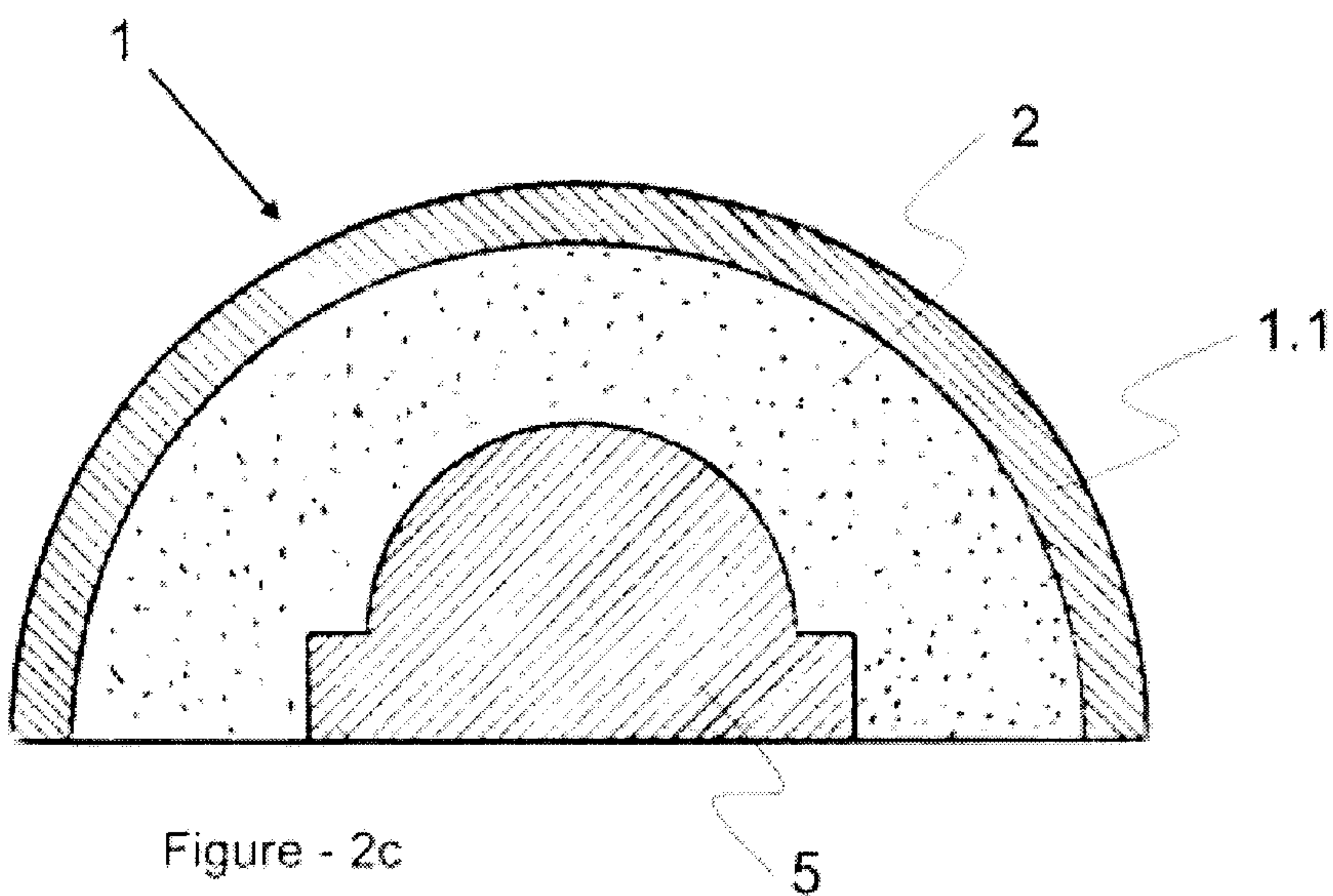

Figure - 2c

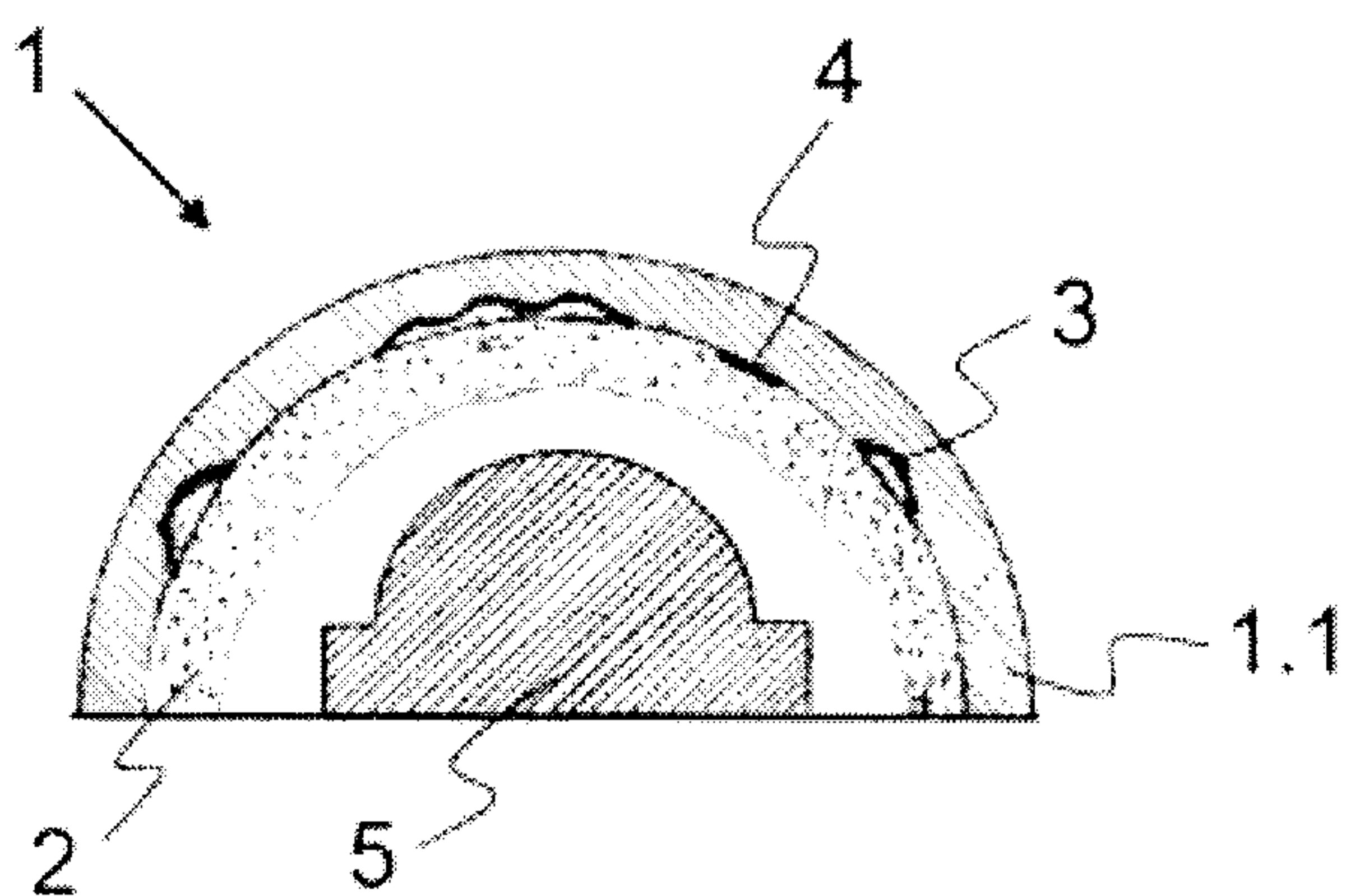

Figure - 2d

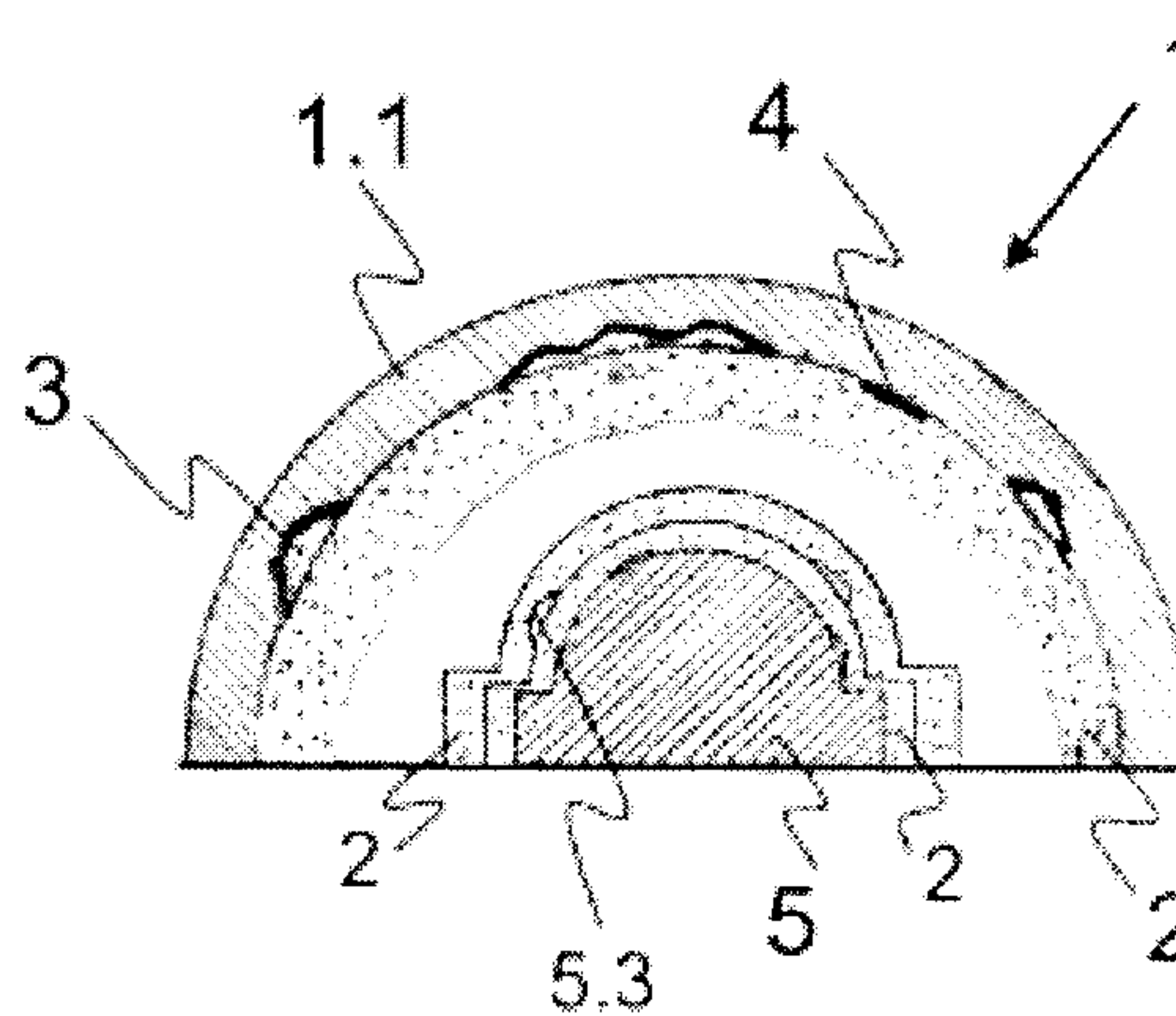

Figure - 2e

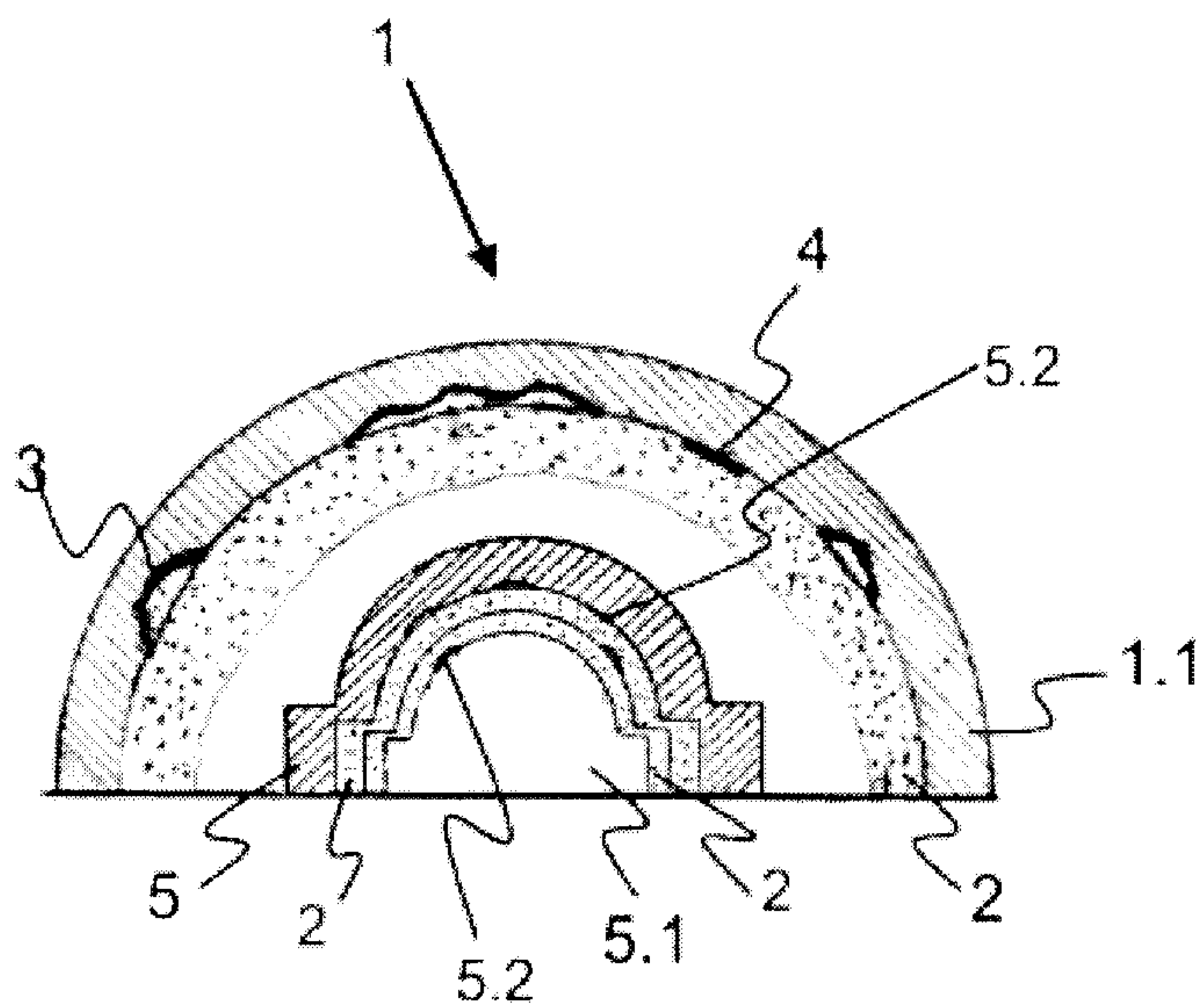

Figure - 2f

