



(51) International Patent Classification:
E05F 3/20 (2006.01)

(21) International Application Number:
PCT/IB2020/051429

(22) International Filing Date:
20 February 2020 (20.02.2020)

(25) Filing Language: Italian

(26) Publication Language: English

(30) Priority Data:
102019000004791 29 March 2019 (29.03.2019) IT

(71) Applicant: COLCOM GROUP S.P.A. [IT/IT]; Via degli Artigiani, 56 int. 1, 25075 Nave (BS) (IT).

(72) Inventors: **BENEDETTI, Luca**; C/O COLCOM GROUP S.P.A., Via degli Artigiani, 56 int., 1, 25075 Nave (BS) (IT). **MESAROS, Mihai**; C/O COLCOM GROUP S.P.A., Via degli Artigiani, 56 int., 1, 25075 Nave (BS) (IT).

(74) Agent: **AUTUORI, Angelo**; C/O AUTUORI & PARTNERS, Via Monte Cengio, 32, 36100 Vicenza (IT).

(81) Designated States (unless otherwise indicated, for every kind of national protection available): AE, AG, AL, AM, AO, AT, AU, AZ, BA, BB, BG, BH, BN, BR, BW, BY, BZ, CA, CH, CL, CN, CO, CR, CU, CZ, DE, DJ, DK, DM, DO, DZ, EC, EE, EG, ES, FI, GB, GD, GE, GH, GM, GT, HN,

HR, HU, ID, IL, IN, IR, IS, JO, JP, KE, KG, KH, KN, KP, KR, KW, KZ, LA, LC, LK, LR, LS, LU, LY, MA, MD, ME, MG, MK, MN, MW, MX, MY, MZ, NA, NG, NI, NO, NZ, OM, PA, PE, PG, PH, PL, PT, QA, RO, RS, RU, RW, SA, SC, SD, SE, SG, SK, SL, ST, SV, SY, TH, TJ, TM, TN, TR, TT, TZ, UA, UG, US, UZ, VC, VN, WS, ZA, ZM, ZW.

(84) Designated States (unless otherwise indicated, for every kind of regional protection available): ARIPO (BW, GH, GM, KE, LR, LS, MW, MZ, NA, RW, SD, SL, ST, SZ, TZ, UG, ZM, ZW), Eurasian (AM, AZ, BY, KG, KZ, RU, TJ, TM), European (AL, AT, BE, BG, CH, CY, CZ, DE, DK, EE, ES, FI, FR, GB, GR, HR, HU, IE, IS, IT, LT, LU, LV, MC, MK, MT, NL, NO, PL, PT, RO, RS, SE, SI, SK, SM, TR), OAPI (BF, BJ, CF, CG, CI, CM, GA, GN, GQ, GW, KM, ML, MR, NE, SN, TD, TG).

Published:
— with international search report (Art. 21(3))

(54) Title: HINGE DEVICE FOR DOOR LEAVES IN GLASS OR THE LIKE

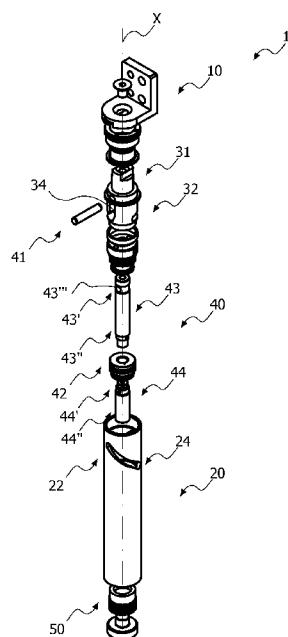

FIG. 1A

(57) Abstract: A hinge device for the controlled rotary opening and closing movement of a closing element (A), such as a door leaf or the like preferably in glass, anchored to a stationary support structure (S), such as a frame preferably in glass. The device comprises a fixed element (10) that can be anchored to the stationary support structure (S) and a movable element (20) that can be anchored to the closing element (A), mutually coupled so as to rotate around a longitudinal axis (X) between at least one first open position and one closed position. The movable element (20) comprises an end portion (22), at least one working chamber (21), a shaft (30) inserted in the latter and a stem (40) inserted into the shaft (30) to slide along the axis (X). Furthermore, provided for is a pin (41) for operatively connecting the end portion (22), the shaft (30) and the stem (40) so that the sliding of the stem (40) along the first axis (X) or an axis parallel thereto corresponds to the rotation of the movable (20) and fixed (10) elements around the axis (X). The working chamber (21) includes a working fluid for the hydraulic damping of the mutual movement of the fixed and movable elements (10, 20) and elastic damping means (50) in a spatial relationship from the stem (40) so that the latter abuts against the former exclusively when the stem (40) is in an end-stop position, so that a user who moves the closing element (A) feels the resistance of the elastic damping means (50) only upon reaching at least the first open position.



HINGE DEVICE FOR DOOR LEAVES IN GLASS OR THE LIKE**DESCRIPTION**Field of the invention

5 The present invention is generally applicable to the technical field of hinges for closing and controlling door leaves for showcases or similar closing elements, and in particular it regards a hinge device for the movement and for the controlled rotary opening and closing of a closing element, such as for example a glass door leaf of a showcase or the like, anchored to a stationary support structure, such as for example a frame.

State of the Art

10 It is known to use plexiglass showcases used to contain foodstuffs, such as for example bread, which are easily accessible to users by rotating the door leaf around a horizontal or vertical hinging axis.

As known, hinges comprise a movable element, usually fixed to the door leaf of the showcase, or the like, hinged to a fixed element, usually fixed to the support frame of the latter.

Often, such hinges are mainly of the mechanical type and they do not provide any kind of opening and/or closing control.

It is also known that such door leaves are subject to possible forced opening due to the use of incautious users.

20 As a matter of fact, such known devices do not provide an opening block and the door leaves are therefore subject to possible unhinging and/or damage.

Furthermore, in the light of the aforementioned inconveniences, it is not known to use the glass to make the door leaves of the showcases in question, with ensuing limitation of the materials used for making the same.

25 Summary of the invention

An object of the present invention is to at least partly overcome the aforementioned drawbacks, by providing a hinge device that is highly functional, easy to manufacture and inexpensive.

30 Another object of the invention is to provide a hinge device that allows a simple and practical adjustment of the opening and closing of the closing element to which it is constrained.

Another object of the invention is to provide a hinge capable of guaranteeing the controlled movement of the door leaf to which it is constrained, both during the opening and closing.

5 Another object of the invention is to provide a hinge device suitable for the controlled opening and closing of glass door leaves.

Another object of the invention is to provide a hinge device that has a minimum number of components.

Another object of the invention is to provide a hinge device capable of maintaining the exact closing position over time.

10 Another object of the invention is to provide a hinge device that is extremely safe.

Another object of the invention is to provide a hinge device that is extremely easy to install.

15 These and other objects to be further clarified hereinafter, are achieved by a hinge device having one or more of the characteristics described and/or claimed and/or illustrated herein.

Advantageous embodiments of the invention are defined according to the dependent claims.

Brief description of the drawings

20 Further characteristics and advantages of the invention will be more apparent in the light of the detailed description of some preferred but non-exclusive embodiments of a hinge device according to the invention, illustrated by way of non-limiting example with reference to the attached drawings, wherein:

FIG. 1A is an exploded view of a hinge device **1**;

25 **FIG. 1B** is an axonometric view of the shaft **30**, regarding which **FIG. 1C** is a lateral view;

FIG. 2A is a lateral view of the hinge device **1** of **FIG. 1A** in which the closing element **A** is in closed position, regarding which **FIG. 2B** is a sectional view taken along a plane I-I;

30 **FIG. 3A** is a lateral view of the hinge device **1** of **FIG. 1A** in which the closing element **A** is open by an angle β equal to 180° , regarding which **FIG. 3B** is a sectional view taken along a plane II-II;

FIG. 4A is a front view of the hinge device **1** of **FIG. 1A**, regarding which **FIG. 4B** is a

sectional view taken along a plane III-III;

FIG. 5 is an axonometric view of the hinge device **1** and of a portion of the closing element **A** that can be directly coupled to the hinge device **1**;

FIG. 6A is a front view of the assembly consisting of the hinge device **1** and the closing element **A**, regarding which **FIGS. 6B** and **6C** are top and lateral views, respectively;

FIG. 7A is an axonometric view of the hinge device **1** in which the closing element **A** is in closed position, regarding which **FIGS. 7B** and **7C** are the corresponding axonometric and top views of the assembly consisting of a pair of hinge devices **1** and the closing element **A**;

FIG. 8A is an axonometric view of the hinge device **1** in which the closing element **A** is in the first open position, regarding which **FIGS. 8B** and **8C** are the corresponding axonometric and top views of the assembly consisting of a pair of hinge devices **1** and the closing element **A**;

FIG. 9A is an axonometric view of the hinge device **1** wherein the closing element **A** is in the third open position (in which the angle β has a value comprised between 85° and 110° , in particular 110° in this case), regarding which **FIGS. 9B** and **9C** are the corresponding axonometric and top views of the assembly consisting of a pair of hinge devices **1** and the closing element **A**;

FIGS. 10A and **11A** are axonometric views of the hinge device **1** wherein the closing element **A** is in the second open position (in which the angle β has a value comprised between 110° and 180° , in particular 165° and 180° in this case), regarding which **FIGS. 10B**, **11B** and **10C**, **11C** are the corresponding axonometric and top views of the assembly consisting of a pair of hinge devices **1** and the closing element **A**;

FIG. 12A is a lateral view of the hinge device **1** of **FIG. 1A** wherein the valve means **60** are in a further embodiment;

FIGS. 12B and **12C** are respectively a sectional view along a plane IV-IV and a sectional view along a plane V-V of the embodiment of **FIG. 12A**;

FIG. 13A is a top view of the valve means **60** of the embodiment illustrated in **FIG. 12B**, regarding which **FIG. 13B** is a sectional view along a plane VI-VI.

Detailed description of some preferred embodiments

With reference to the mentioned figures, herein described is a hinge device **1** for the controlled rotary opening and closing movement of a closing element **A**, such as a door leaf

or the like preferably in glass, anchored to a stationary support structure **S**, such as a frame preferably in glass.

The present invention can include various parts and/or similar or identical elements. Unless otherwise specified, similar or identical parts and/or elements will be indicated using a single reference number, it being clear that the described technical features are common to all similar or identical parts and/or elements.

Generally, the hinge device **1** can include a fixed element **10** that can be anchored to the frame **S** and a movable element **20** that can be anchored to the door leaf **A**.

Suitably, the fixed **10** and movable **20** elements will be coupled to each other so as to rotate around a longitudinal axis **X** between a closed position, illustrated for example in **FIG.7A**, and at least one open position, illustrated for example in **FIG.8A**.

Suitably, the fixed **10** and movable **20** elements can include a respective first and second fixing portion **15**, **25** for anchoring to the frame **S** and to the door leaf **A**.

Preferably, the movable element **20** can include a working chamber **21** defining the axis **X** and a stem **40** slidable therein between at least two end-stop positions.

The working chamber **21** can also comprise elastic damping means **50** which are susceptible to abut against the stem **40** so as to dampen the motion thereof by imparting an opposing force so as to oppose the movement of the door leaf **A** by the user, as will be described in more detail below.

According to a preferred but not exclusive embodiment, the stem **40** can be coupled to a plunger element **42** so that they slide integrally along the axis **X**.

The stem **40** can comprise a portion **43** comprising an end **43'** at which a housing hole **43'''** into which a pin **41** can be inserted can be provided.

The portion **43** can further comprise an end **43''** coupled, preferably by screwing, to the plunger element **42**.

Suitably, the stem **40** can further comprise a portion **44** comprising an end **44'** coupled to the plunger element **42**, preferably by screwing, and an opposite end **44''** suitable to abut against the elastic damping means **50**.

As particularly illustrated in **FIG.2B**, the working chamber **21** can comprise a housing area **51** in which the elastic damping means **50** can be accommodated.

These can comprise a pressing member **52** and a damping element **53**, such as for example a belleville washer, as illustrated in **FIG.4B**, or a polyurethane elastomer body, as illustrated in **FIG.2B**, suitable to occupy the housing area **51** upon the compression thereof.

Such damping elements **53** can impart a high opposing force upon minimal
5 compressions.

Conveniently, the working chamber **21** can include a working fluid for the hydraulic damping of the movement of the movable element **20** around the axis **X**.

Conveniently, the plunger element **42** can divide the working chamber **21** into a first and a second variable-volume compartment **23'**, **23''**, which can be placed in fluid
10 communication using valve means **60**.

Such valve means **60** can comprise a calibrated opening **62** and an opening **61** comprising a shutter **61'** susceptible to open when the door leaf **A** is opened and close when the door leaf is closed, so as to force the working fluid to flow exclusively through the second calibrated opening **62**, as disclosed in the applications PCT/IB2015/050603,
15 PCT/IB2017/05836 or in the Italian application 102018000008233.

Preferably, the opening **61** and the shutter **61'** can be part of a check valve.

Even more preferably, the calibrated opening **62** can have a diameter of suitable size, possibly small, so as to dampen the closure of the door leaf **A**, depending on the desired
20 degree.

Conveniently, the hinge device **1** can comprise a shaft **30** inserted into the working
chamber **21** along the axis **X**.

The shaft **30** can comprise a connection portion **31** for connecting the fixed **10** and movable **20** elements.

The shaft **30** can also comprise a tubular working portion **32** opposite the connection
25 portion **31**.

Suitably, the tubular working portion **32** can comprise a pair of slots **34** facing each other.

Each slot **34** can comprise a portion **35** extending along an axis **X'** parallel to the axis **X** and a portion **37** extending along an axis **Y**.

Preferably, the axis **Y** can be incident to the axis **X'** so that an angle α greater than 90°
30 can be defined between the portion **35** and the portion **37**, as shown in particular in **FIG. 1C**.

It is clear that the angle α can be substantially equal to 90° , without departing from the scope of protection of the attached claims.

Suitably, a portion **36** defining an axis **Z** substantially transversal with respect to the axes **X'** and **Y**, can be interposed between the portions **35** and **37**.

5 The portion **36** can comprise a guide surface **36'** inclined corresponding to the axis **Z**.

According to a preferred but non-exclusive embodiment, the working chamber **21** can further comprise an end portion **22** comprising a pair of actuator slots **24**.

Preferably, the slots **24** can be arranged facing each other and rotating around the axis **X**.

10 More particularly, the slots **24** can have a rightward or leftward development.

According to the embodiment illustrated in **FIG.1A**, the slots **24** can have a leftward development.

Conveniently, the stem **40** can be inserted into the tubular working portion **32** so that the pin **41** can slide along the slots **24** and **34**.

15 In particular, each pair of slots **24** and **34** can constitute a single guide element for the pin **41**.

More particularly, during the movement of the door leaf **A** and thus upon the rotation of the fixed element **10** and the movable element **20** around the axis **X**, the slots **24** can guide the movement of the pin **41** along the slots **34**.

20 However, it is clear that a single pair of slots can be formed in the tubular working portion **32** or in the movable element **20** without departing from the scope of protection of the attached claims.

25 Furthermore, it is clear that two or more slots can be formed in the tubular working portion **32** and/or in the end portion **22** without departing from the scope of protection of the attached claims.

30 Operatively, as particularly illustrated in **FIG.8A**, when the door leaf **A** is moved to open by an angle β comprised for example between 0° and 85° , the pin **41** can slide along the portion **35** and the stem **40** can be moved from a first end-stop position in which the end **43'** is proximal to the connection portion **31** of the shaft **30**, to a second end-stop position in which the end **43'** is distal therefrom.

More particularly, when the door leaf **A** is in a first opening position, corresponding

for example to an angle β of 85° , the end **44''** of the stem **40** will come into contact with the pressing member **52**.

Starting from this angle, the door leaf **A** can close automatically in a damped manner solely due to the action of the previously described hydraulic circuit.

5 As shown in **FIG. 9A**, when the door leaf **A** is moved to open by an angle β comprised between 85° and 110° , corresponding to a third open position, the pin **41** can slide along the portion **36** and the stem **40** can be moved from the second to a third end-stop position with ensuing compression of the damping element **53**.

10 Starting with a value of β comprised between 85° and 110° , the door leaf **A** can thus be closed automatically due to the work of the damping means **50** which will push the pin **41** to abut against the guide surface **36'** which will direct the pin **41** along the portion **35** to reach the aforementioned first open position.

Starting from such position, the door leaf **A** can reach the closed position as described previously.

15 Furthermore, such closure can be suitably damped by the previously described hydraulic circuit.

As illustrated in **FIGS. 10A-11A**, when the door leaf **A** is moved to open by an angle β comprised between 110° and 180° , corresponding to a second open position, the pin **41** can slide along the portion **36** and the stem **40** can be moved from the third to a fourth end-stop position with ensuing further compression of the damping element **53**.

20 In particular, as a result of opening angles β greater than 110° , the door leaf **A** will lock in the position reached due to the countering force generated by the damping element **53** which will push the pin **41** to abut against the abutment surface **37'** of the portion **37**, as particularly illustrated in **FIGS. 10A-11A**.

25 The user will then have to manually return the door leaf **A** up to an angle β measuring 110° , starting from which the door leaf **A** can be closed automatically as described previously.

30 It is clear that, during the opening of the door leaf **A** and as concerns opening angles β comprised between 85° and 180° , the user can perceive a resistance against the increasing movement, due to the incremental countering force generated by the progressive compression of the damping element **53**.

This resistance will cause the user to avoid forcing the door leaf **A** to open, preventing it from unhinging it.

It is clear that the described hinge device **1** can guarantee the controlled rotary opening and closing movement of closing elements **A**, in particular glass door leaves.

5 In light of the above, it is clear that the invention attains the pre-set objectives.

The invention is susceptible to numerous modifications and variants all falling within the inventive concept outlined in the attached claims. All details can be replaced by other technically equivalent elements, and the materials can be different depending on the technical needs, without departing from the scope of protection defined by the attached
10 claims.

CLAIMS

1. A hydraulic hinge device for the controlled rotary opening and closing movement of a closing element **(A)**, such as a door leaf or the like preferably in glass, anchored to a stationary support structure **(S)**, such as a frame preferably in glass, the device comprising:

5 - a fixed element **(10)** that can be anchored to the stationary support structure **(S)**;
 - a movable element **(20)** that can be anchored to the closing element **(A)**, said movable element **(20)** and said fixed element **(10)** being mutually coupled to rotate around a first longitudinal axis **(X)** between at least one first open position and one closed position, one from among said movable element **(20)** and said fixed element **(10)** comprising at least
10 one working chamber **(21)** defining said first axis **(X)**;

 - a shaft **(30)** coaxially inserted into said at least one working chamber **(21)**, said shaft **(30)** comprising a connection portion **(31)** for operatively connecting said fixed and movable elements **(10, 20)** to each other, said shaft **(30)** further comprising a tubular working portion **(32)**;

15 - a stem **(40)** telescopically inserted into said tubular working portion **(32)** so as to slide along said first axis **(X)** between a first end-stop position proximal to said connection portion **(31)** of said shaft **(30)**, corresponding to one from among said at least one open position and one closed position, and at least one second end-stop position distal from said connection portion **(31)** of said shaft **(30)**, corresponding to the other of said at least one
20 open position and one closed position, a pin **(41)** for operatively connecting said tubular working portion **(32)** and said stem **(40)** being provided for so that the sliding of said stem **(40)** along the first axis **(X)** or an axis parallel thereto corresponds to the rotation of said one of said movable element **(20)** and said fixed element **(10)** around said first axis **(X)**;

 wherein said at least one working chamber **(21)** includes a working fluid for the
25 hydraulic damping of the mutual movement of said fixed and movable elements **(10, 20)** and at least one plunger element **(42)** integrally coupled with said stem **(40)** to integrally move therewith along said first axis **(X)**, said at least one plunger element **(42)** dividing said at least one working chamber **(21)** into at least one first and one second variable-volume compartment **(23', 23'')** fluidly communicating with each other and preferably adjacent,
30 valve means **(60)** being provided for to control the flow of the working fluid between said first and second variable-volume compartments **(23', 23'')**;

wherein said at least one working chamber (21) further comprises elastic damping means (50) in a spatial relationship with said stem (40) so that the latter or said plunger element (42) abuts against the former exclusively when said stem (40) is in said second end-stop position, so that a user who moves the closing element (A) feels the resistance of said elastic damping means (50) exclusively upon reaching one from among the closed position and the first open position.

2. Hinge device according to claim 1, wherein said stem (40) comprises an end (40'') inserted into said tubular working portion (32) of said shaft (30) which includes said pin (41), one from among the latter and said one from among said movable element (20) and said fixed element (10) comprising at least one pair of first actuator slots (24) rotating around said first axis (X), said pin (41) being inserted into said first actuator slots (24) to slide therethrough upon the mutual rotation of said fixed and movable elements (10, 20) around said first axis (X).

3. Hinge device according to claim 2, wherein said at least one working chamber (21) includes at least one end portion (22) mutually facing the other of said movable element (20) and said fixed element (10), said shaft (30) being coaxially inserted into said at least one working chamber (21) at said end portion (22), one from among said at least one end portion (22) of said working chamber (21) and said tubular working portion (32) of said shaft (30) comprising said first actuator slots (24), the other from among said at least one end portion (22) of said working chamber (21) and said tubular working portion (32) of said shaft (30) comprising at least one pair of second guide slots (34), said pin (41) sliding through said first actuator slots (24) and said second guide slots (34).

4. Hinge device according to the preceding claim, wherein said first actuator slots (24) have rightward or a leftward development, said second guide slots (34) comprising at least one first portion (35) defining a second axis (X') substantially parallel or slightly inclined with respect to said first axis (X), said pin (41) sliding through said at least one first portion (35) of said second guide slots (34) so as to allow the movement of said closing element between said first open position and said closed position.

5. Hinge device according to the preceding claim, wherein said second guide slots (34) further comprise a second portion (37) angularly spaced with respect to said first portion (35) so as to define a third axis (Y), said pin (41) sliding through said at least one first

portion (35) and in said second portion (37) of said second guide slots (34) so as to allow the movement of said closing element between a second open position and said closed position passing through said first open position, said third axis (Y) being substantially perpendicular or slightly inclined with respect to said first axis (X) so that when the closing element is in
5 said second open position, said pin (41) abuts against an abutment surface (37') of said second portion (37) under the thrust of said elastic damping means (50).

6. Hinge device according to the preceding claim, wherein said second guide slots (34) further comprise a third portion (36) interposed between said first and second portions (35, 37), said pin (41) sliding in said first, second and third portions (35, 36, 37) of said
10 second guide slots (34) so as to allow the movement of said closing element between said second open position and said closed position passing through said first open position and through at least one third open position interposed between said first and second open positions, said third portion (36) defining a fourth axis (Z) transverse with respect to said second and third axes (X', Y) so that when the closing element is in said third open position
15 said pin (41) abuts against a guide surface (36') of said third portion (36) inclined corresponding to said fourth axis (Z) so as to be automatically thrust toward said first portion (35) by said elastic damping means (50), so that the closing element snaps towards said first open position.

7. Hinge device according to any one of the preceding claims, wherein said stem (40)
20 comprises a first portion (43) comprising a first end (43') integrally coupled to said pin (41) and an opposite second end (43'') mutually coupled to said plunger element (42), said stem (40) further comprising a second portion (44) comprising a third end (44') mutually coupled to said plunger element (42) and an opposite fourth end (44'') susceptible to abut against said elastic damping means (50), said first portion (43), said plunger element (42) and said
25 second portion (44) moving integrally along said first axis (X).

8. Hinge device according to the preceding claim, wherein said working chamber (21) comprises a housing area (51) for said elastic damping means (50), the latter comprising at least one pressing member (52) and a damping element (53), said at least one pressing member (52) being susceptible to mutually abut against said second end (44'') of said
30 second portion (44) of said stem (40) when the closing element (A) reaches the first open position, said damping element (53) being preferably a belleville washer or a polyurethane

elastomer body.

9. Hinge device according to the preceding claim, wherein said damping element **(53)** is a polyurethane elastomer body suitable to completely occupy said housing area **(51)** once said polyurethane elastomer body is compressed by said at least one pressing member **(52)**.

- 5 10. Hinge device according to any one of the preceding claims, wherein said valve means **(60)** comprise at least one first and at least one second opening **(61, 62)** so as to place said first and second variable-volume compartments **(23', 23'')** in fluid communication, said at least one first opening **(61)** comprising at least one shutter **(61')** susceptible to open upon the opening of the closing element **(A)** and susceptible to close upon the closing of the closing element **(A)** to force the working fluid to flow exclusively through said second opening **(62)**.
- 10

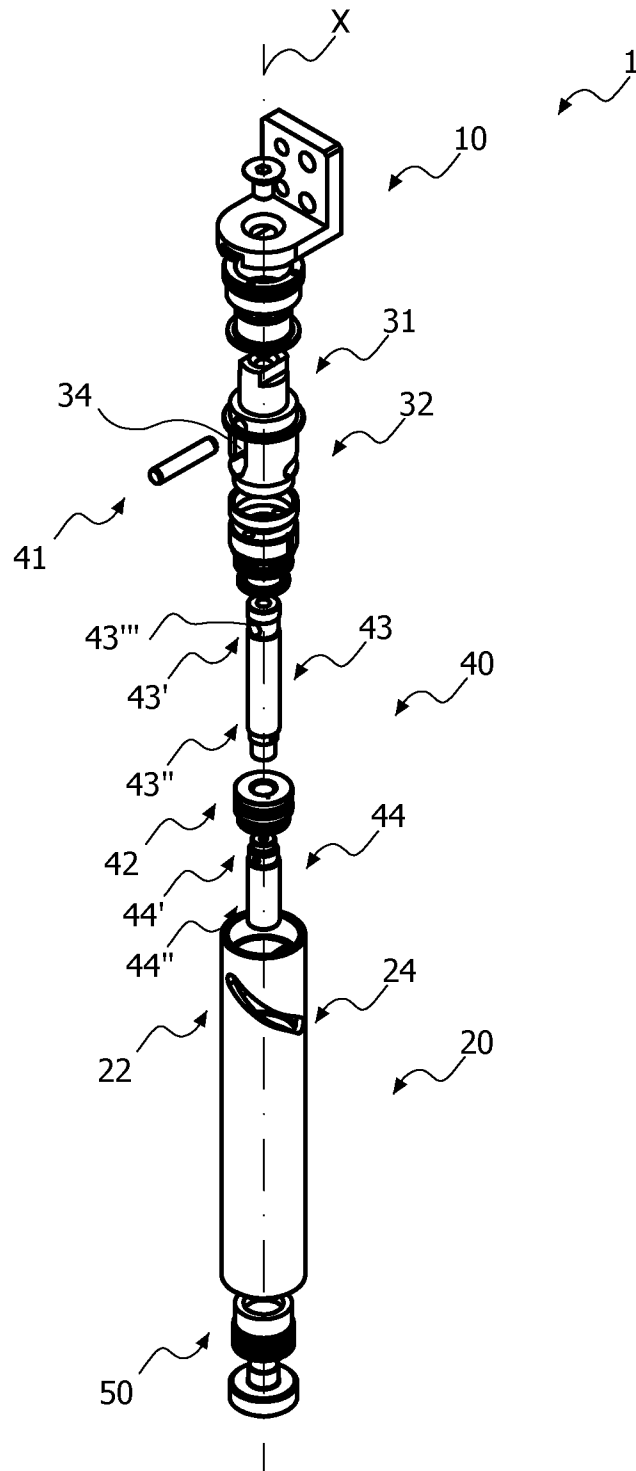

FIG. 1A

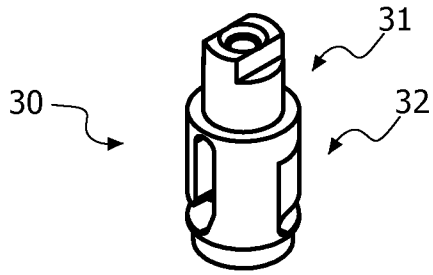

FIG. 1B

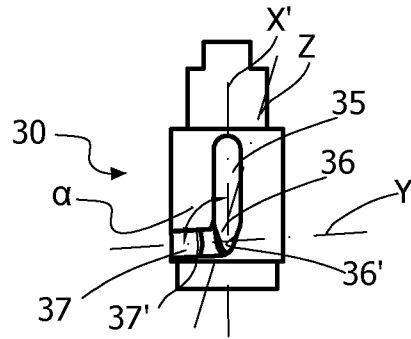

FIG. 1C

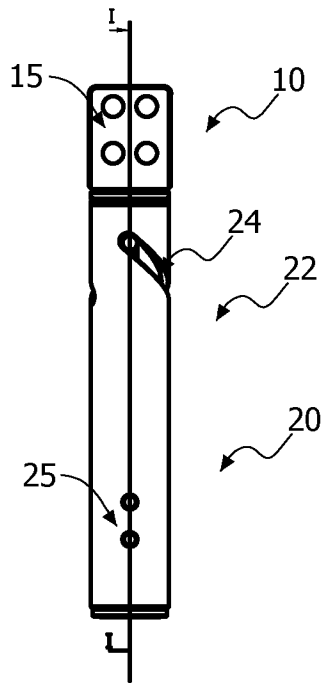

FIG. 2A

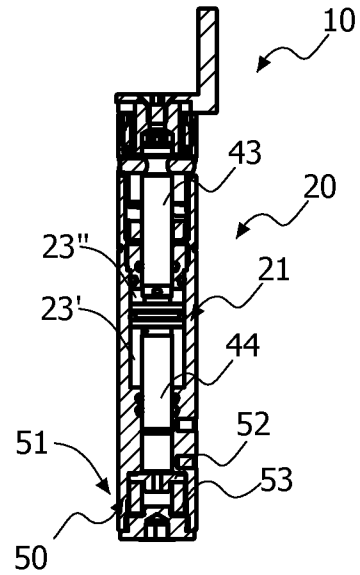

FIG. 2B

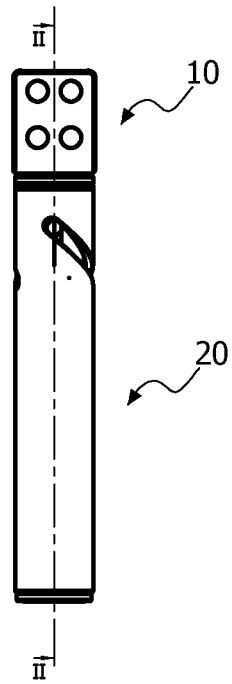

FIG. 3A

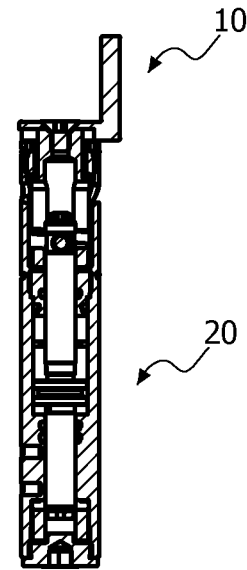

FIG. 3B

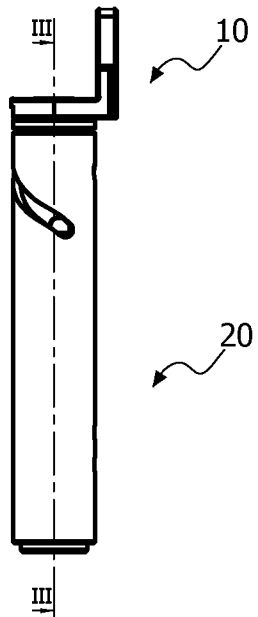

FIG. 4A

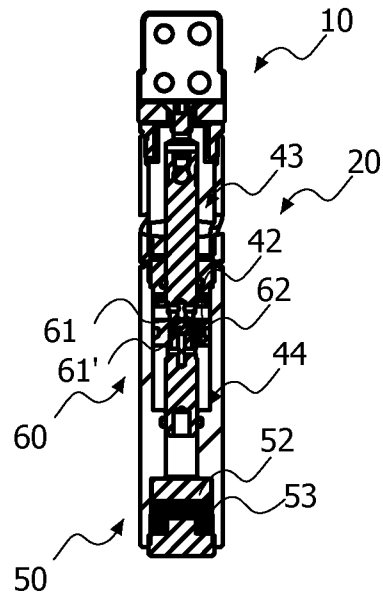

FIG. 4B

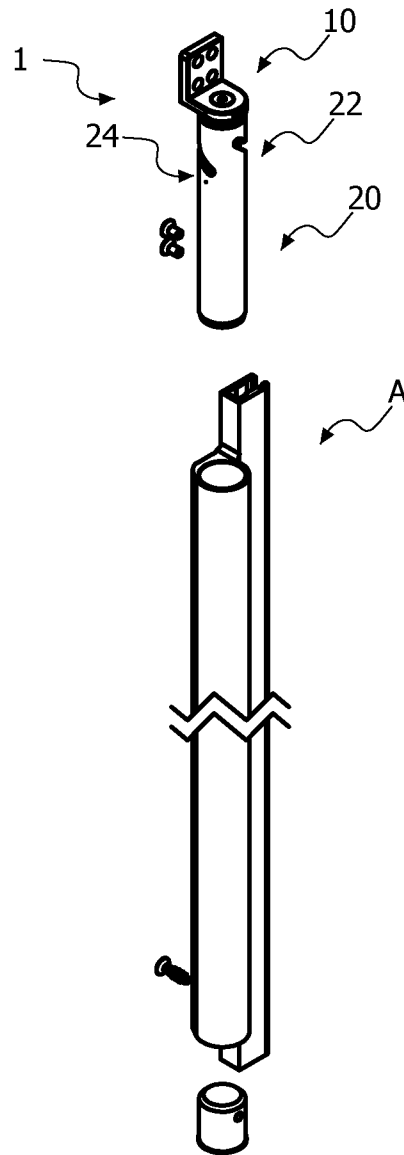

FIG. 5

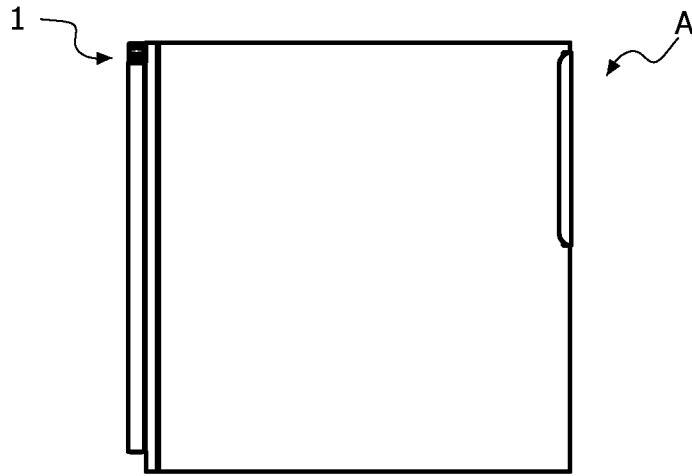

FIG. 6A



FIG. 6B

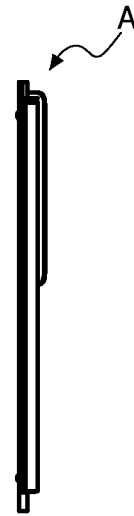

FIG. 6C

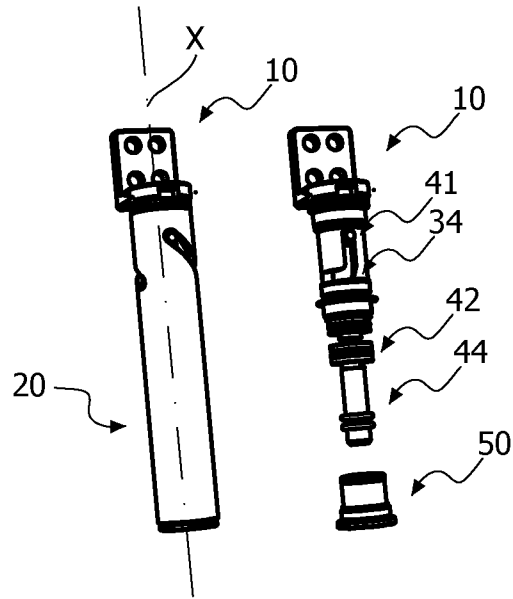

FIG. 7A

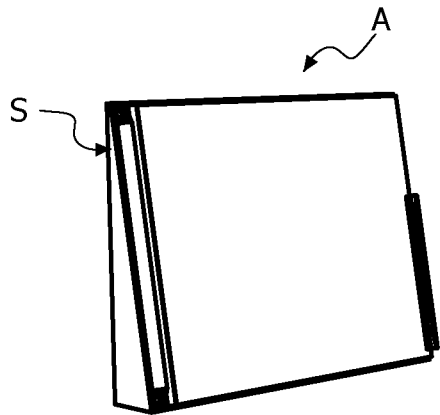

FIG. 7B

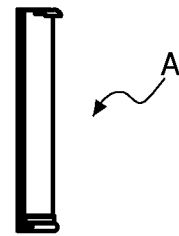

FIG. 7C

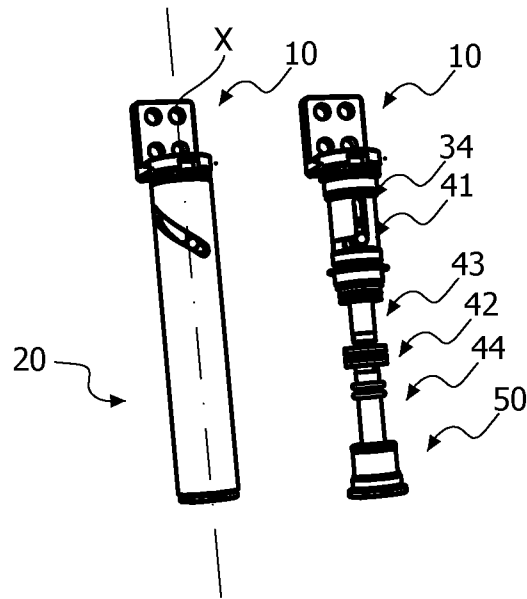

FIG. 8A

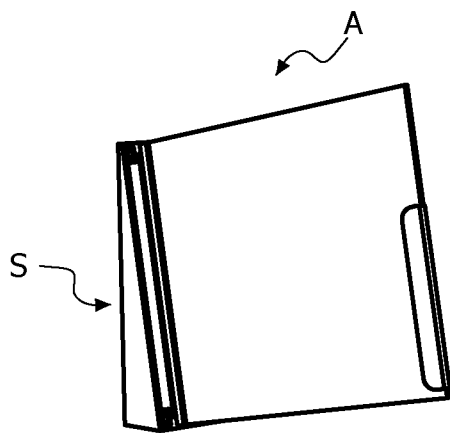

FIG. 8B

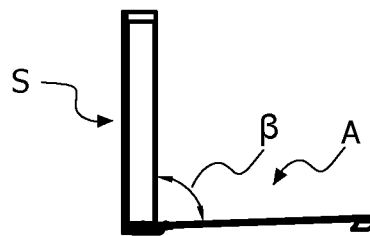
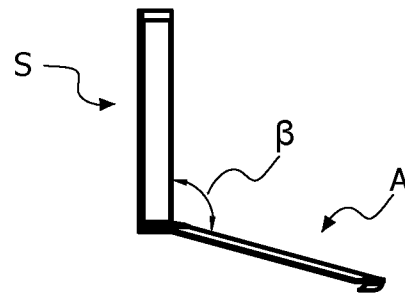
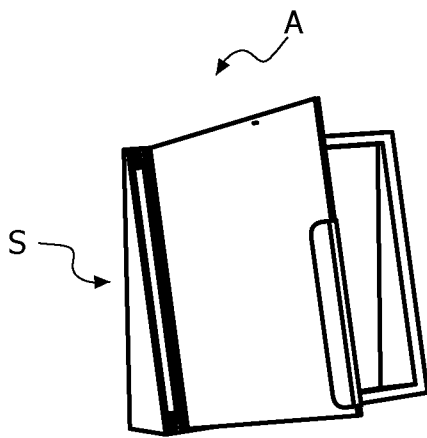
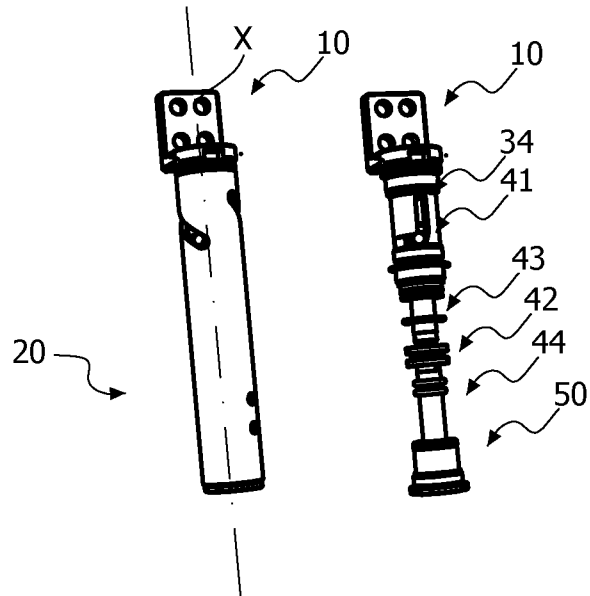

FIG. 8C



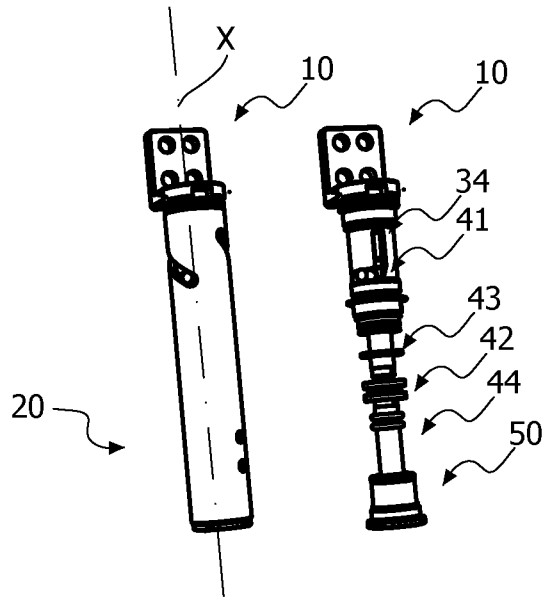

FIG. 10A

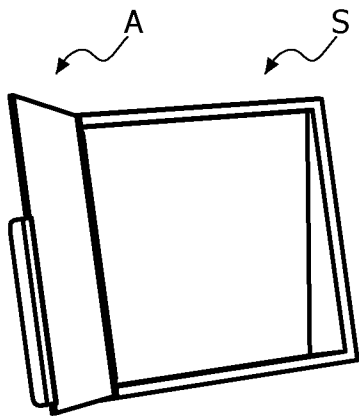

FIG. 10B

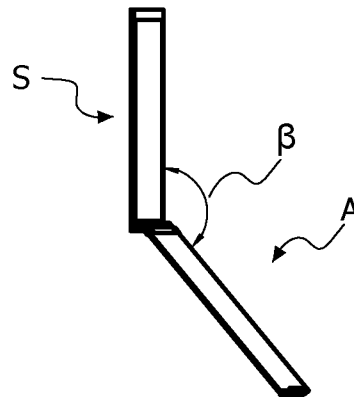

FIG. 10C

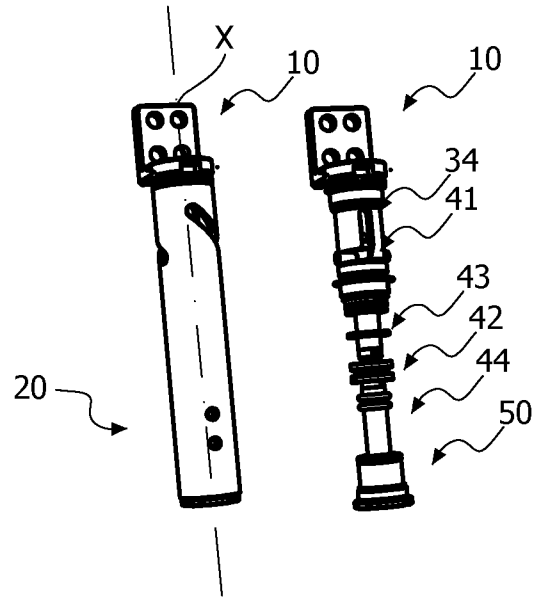

FIG. 11A

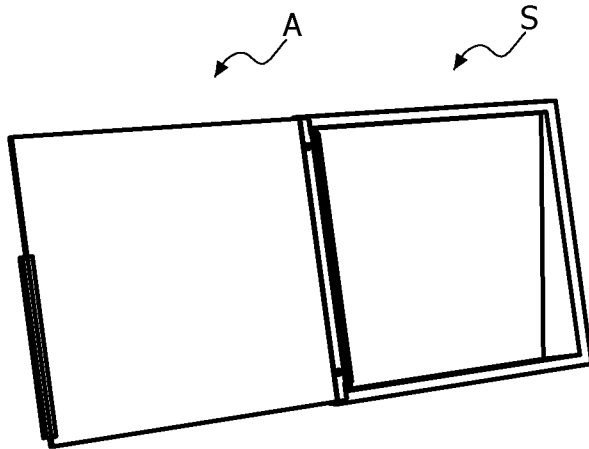

FIG. 11B

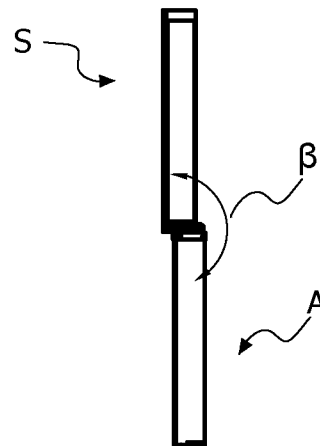

FIG. 11C

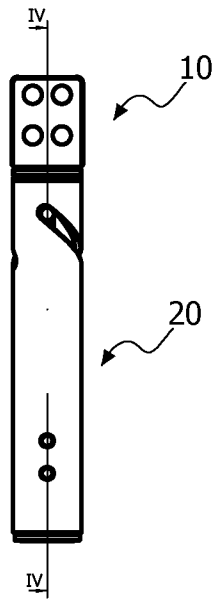

FIG. 12A

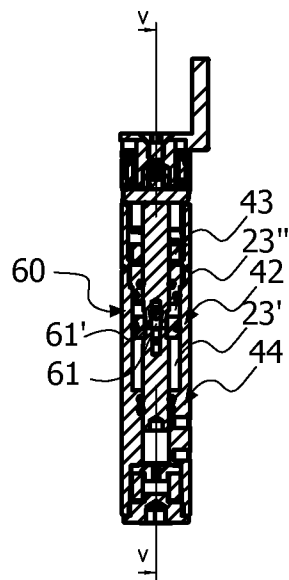

FIG. 12B

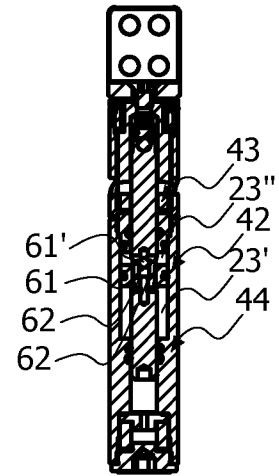

FIG. 12C

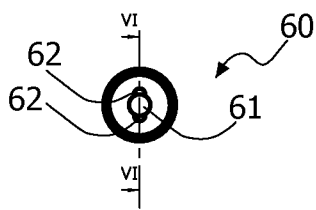

FIG. 13A

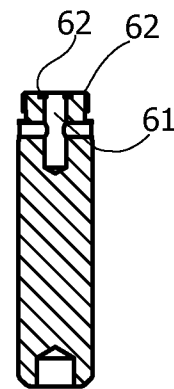

FIG. 13B

INTERNATIONAL SEARCH REPORT

International application No
PCT/IB2020/051429

A. CLASSIFICATION OF SUBJECT MATTER

INV. E05F3/20
ADD.

According to International Patent Classification (IPC) or to both national classification and IPC

B. FIELDS SEARCHED

Minimum documentation searched (classification system followed by classification symbols)
E05F

Documentation searched other than minimum documentation to the extent that such documents are included in the fields searched

Electronic data base consulted during the international search (name of data base and, where practicable, search terms used)

EPO-Internal, WPI Data

C. DOCUMENTS CONSIDERED TO BE RELEVANT

Category*	Citation of document, with indication, where appropriate, of the relevant passages	Relevant to claim No.
A	IT VI20 120 258 A1 (IN & TEC SRL) 5 April 2014 (2014-04-05) claims 1, 7 figures 1, 2a, 3a, 4a, 5a, 6a, 7a, 8a, 9a, 10a, 11a, 12a figures 13a, 14a, 15a, 16a, 17a, 18a, 19a, 20, 22	1-10
A	----- EP 3 067 502 A1 (IN & TEC SRL [IT]) 14 September 2016 (2016-09-14) paragraphs [0118] - [0125] paragraphs [0129] - [0136] paragraphs [0200] - [0202] figure 7	1-10
A	----- WO 2016/055929 A1 (IN & TEC SRL [IT]) 14 April 2016 (2016-04-14) the whole document ----- -/--	1

 Further documents are listed in the continuation of Box C. See patent family annex.

* Special categories of cited documents :

"A" document defining the general state of the art which is not considered to be of particular relevance

"E" earlier application or patent but published on or after the international filing date

"L" document which may throw doubts on priority claim(s) or which is cited to establish the publication date of another citation or other special reason (as specified)

"O" document referring to an oral disclosure, use, exhibition or other means

"P" document published prior to the international filing date but later than the priority date claimed

"T" later document published after the international filing date or priority date and not in conflict with the application but cited to understand the principle or theory underlying the invention

"X" document of particular relevance; the claimed invention cannot be considered novel or cannot be considered to involve an inventive step when the document is taken alone

"Y" document of particular relevance; the claimed invention cannot be considered to involve an inventive step when the document is combined with one or more other such documents, such combination being obvious to a person skilled in the art

"&" document member of the same patent family

Date of the actual completion of the international search

19 June 2020

Date of mailing of the international search report

02/07/2020

Name and mailing address of the ISA/

European Patent Office, P.B. 5818 Patentlaan 2
NL - 2280 HV Rijswijk
Tel. (+31-70) 340-2040,
Fax: (+31-70) 340-3016

Authorized officer

Mund, André

INTERNATIONAL SEARCH REPORT

International application No
PCT/IB2020/051429

C(Continuation). DOCUMENTS CONSIDERED TO BE RELEVANT

Category*	Citation of document, with indication, where appropriate, of the relevant passages	Relevant to claim No.
A	WO 2006/025663 A1 (I ONE INNOTECH CO LTD [KR]; CHOI SOON WOO [KR]) 9 March 2006 (2006-03-09) the whole document -----	1

INTERNATIONAL SEARCH REPORT

Information on patent family members

International application No

PCT/IB2020/051429

Patent document cited in search report		Publication date	Patent family member(s)	Publication date
IT VI20120258	A1	05-04-2014	-----	-----
EP 3067502	A1	14-09-2016	AU 2012245995 A1	17-10-2013
			BR 112013025759 A2	20-12-2016
			CA 2831729 A1	26-10-2012
			CN 103582734 A	12-02-2014
			DK 2694764 T3	06-06-2016
			DK 3067501 T3	14-01-2019
			EP 2694764 A2	12-02-2014
			EP 3067500 A1	14-09-2016
			EP 3067501 A1	14-09-2016
			EP 3067502 A1	14-09-2016
			ES 2702381 T3	28-02-2019
			HK 1195108 A1	28-10-2016
			HU E027573 T2	28-10-2016
			IL 228631 A	28-09-2017
			JP 6033840 B2	30-11-2016
			JP 2014510214 A	24-04-2014
			NZ 616038 A	27-11-2015
			PL 2694764 T3	30-09-2016
			PL 3067501 T3	31-07-2019
			PT 3067501 T	27-11-2018
			RU 2013148900 A	10-05-2015
			SI 3067501 T1	31-01-2019
			TR 201816531 T4	21-11-2018
			UA 110820 C2	25-02-2016
			US 2014033476 A1	06-02-2014
			US 2015067982 A1	12-03-2015
			US 2015067984 A1	12-03-2015
			US 2016215549 A1	28-07-2016
			WO 2012137042 A1	11-10-2012
			WO 2012143812 A2	26-10-2012
			ZA 201307809 B	29-10-2014
-----	-----	-----	-----	-----
WO 2016055929	A1	14-04-2016	BR 112017007038 A2	30-01-2018
			CA 2963453 A1	14-04-2016
			CN 107109878 A	29-08-2017
			EP 3204582 A1	16-08-2017
			JP 2017534780 A	24-11-2017
			US 2017241180 A1	24-08-2017
			WO 2016055929 A1	14-04-2016
-----	-----	-----	-----	-----
WO 2006025663	A1	09-03-2006	CN 101006243 A	25-07-2007
			KR 20060017228 A	23-02-2006
			WO 2006025663 A1	09-03-2006
-----	-----	-----	-----	-----