

May 5, 1959

D. A. WALL

2,885,500

MOMENTARY CONTACT ADAPTER FOR AUXILIARY SWITCH

Filed Nov. 14, 1957

2 Sheets-Sheet 1

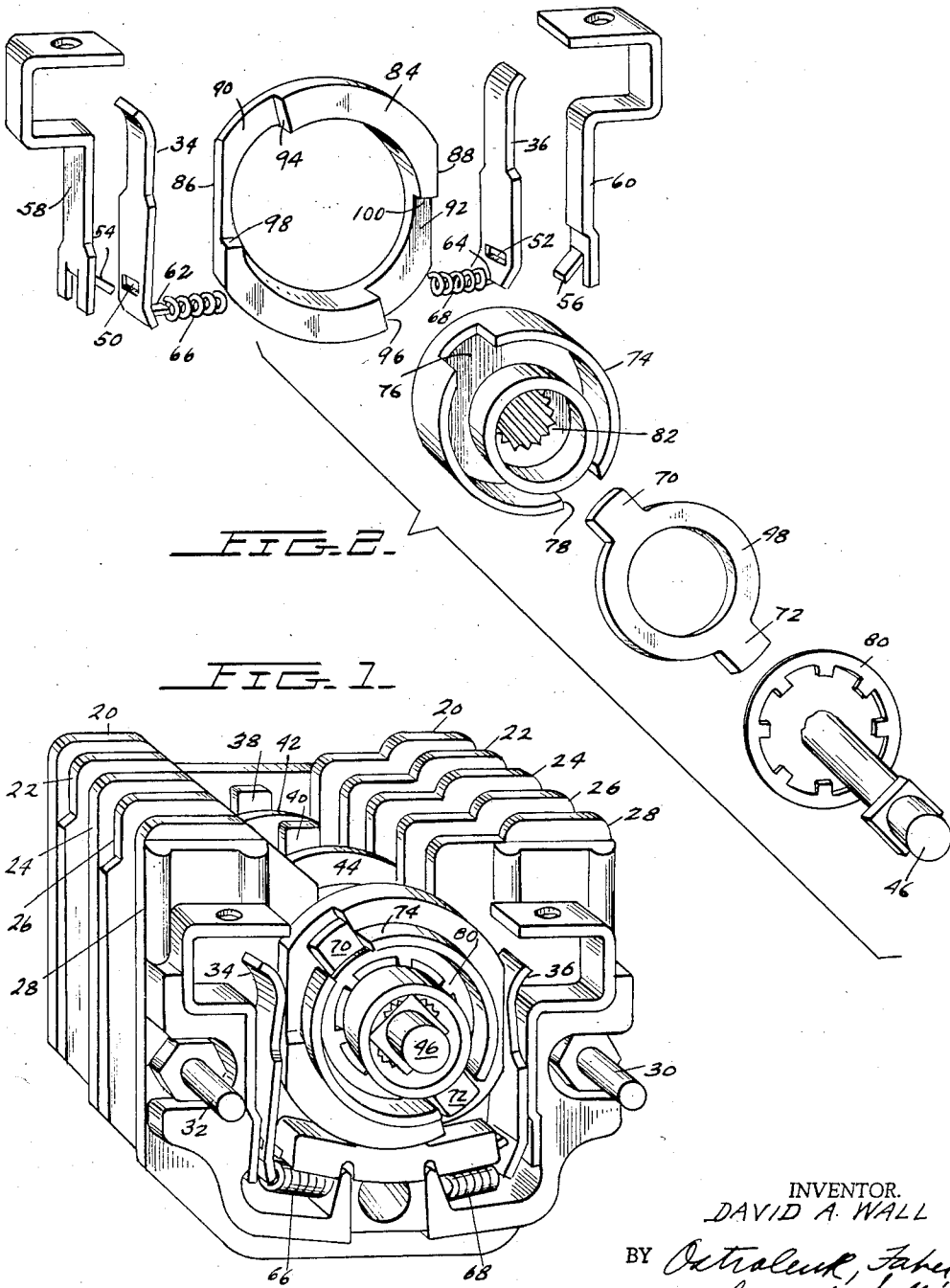

INVENTOR.
DAVID A. WALL
BY *Ostrander, Fisher,
Scott & Saffin*
ATTORNEYS

May 5, 1959

D. A. WALL

2,885,500

MOMENTARY CONTACT ADAPTER FOR AUXILIARY SWITCH

Filed Nov. 14, 1957

2 Sheets-Sheet 2

FIG. 3

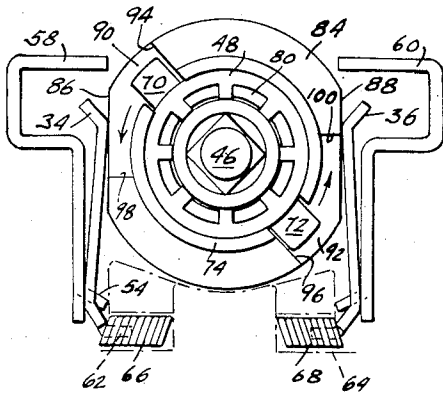

FIG. 4

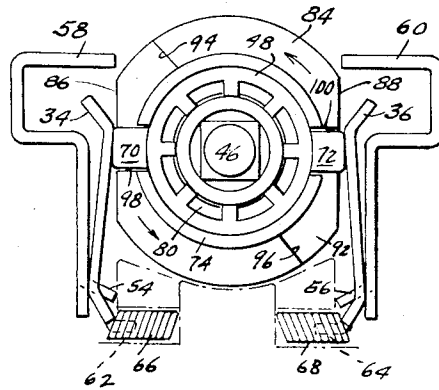

FIG. 6

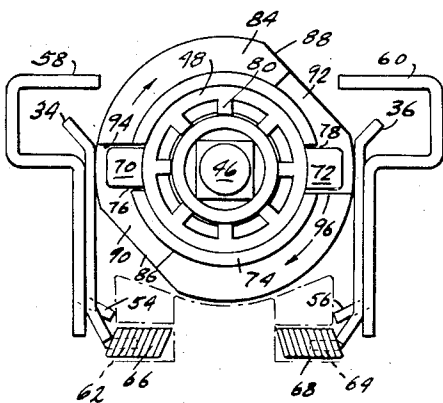
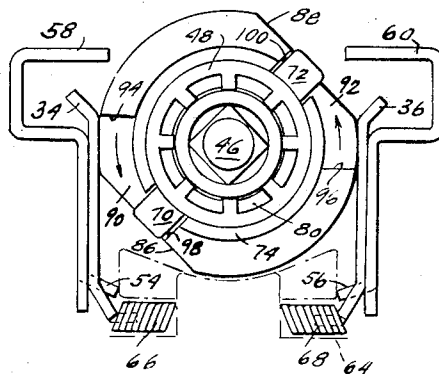

FIG. 5



INVENTOR,
DAVID A. WALL

BY *Ostlund, Fisher,
Leut & Soffen*
ATTORNEYS

1

2,885,500

**MOMENTARY CONTACT ADAPTER FOR
AUXILIARY SWITCH**

David A. Wall, Los Angeles, Calif., assignor, by mesne assignments, to I-T-E Circuit Breaker Company, Philadelphia, Pa., a corporation of Pennsylvania

Application November 14, 1957, Serial No. 696,559

7 Claims. (Cl. 200—6)

My invention relates to a mechanism for adapting a rotary type switch having a plurality of axially arranged contact members with an auxiliary contact for a single momentary make during the complete operating cycle of the switch.

There are many applications of a ganged type switch where it is desirable to have at least one of the contacts perform a momentary make at one point within the complete cycle of the switch. By way of an example, certain types of reclosing relays require the momentary energization of a starting or pick-up circuit.

In the past, it has been necessary to install special separate momentary contact switches for this purpose. This arrangement creates difficulties primarily in synchronizing the operation of the momentary contact switch and the other contact of the switch arrangement and furthermore, is costly in both manufacture and installation.

The primary object of my invention is to provide a novel adaption mechanism for a rotary type switch of standard manufacture which performs a momentary make at some predetermined point within a complete operating cycle of the switch.

Another object of my invention is to provide a novel switch arrangement which provides a plurality of contacts and an auxiliary momentary contact which performs a momentary make operation at a predetermined point within the operating cycle and is directly operable from the same operating shaft that operates the standard contacts.

A still further object of my invention is to provide a ganged rotary switch having a momentary make contact where the simplicity of design makes it easily mass-produced at low cost.

Another object of my invention is to provide a novel momentary make contact adapter for rotary type switches which may be easily added to standard switches.

These and other objects of my invention will become a portion from the operating description when taken in conjunction with the drawings in which:

Figure 1 shows a perspective view of a rotary type switch adapted in accordance with my novel invention.

Figure 2 is an exploded perspective view of the momentary make contact adaption of Figure 1.

Figure 3 is a front view of Figure 1 and shows the momentary make contact at the beginning of the switch operating cycle and in the disengaged position.

Figure 4 is similar to Figure 3 and shows the momentary make contact moved from the position of Figure 3 to a make position.

Figure 5 is similar to Figure 4 and shows the momentary make contact when moved from the make position of Figure 4 to a disengaged position at the end of the first-half cycle of switch operation.

Figure 6 is similar to Figure 5 and shows the momentary contact position when the contact has been moved from the open position of Figure 5 and through the contact position of the second cycle without causing re-

2

engagement between the cooperating momentary make contacts.

As will be seen hereinafter, a preferred embodiment of my invention comprises the addition of an adaptor member to a standard switch mechanism which is rotatable from the rotating contact for at least a portion of the rotation of the rotatable contact.

More specifically at the beginning of a switch operating cycle, the rotating momentary make contact is rotated into engagement with a semi-stationary cooperating contact, and as the rotating contact continues to rotate out of the engaged position, it picks up the adaptor member and causes the adaptor member to move the semi-stationary contact to a position removed from the contact engaging position. When the rotating contact is then rotated back to its original position, the adaptor member is unaffected so that the rotating contact passes by the semi-stationary contact without engaging it. After the rotating contact passes the contact engaging point, it once again picks up the adaptor member and allows the semi-stationary contact to move back to the engaging position for the next cycle.

Referring now to Figure 1, a complete switch assembly is seen therein as comprising a plurality of insulator plate sections 20, 22, 24, 26 and 28 which are fastened together by means of a nut-bolt arrangement 30 and 32 on either side of the switch wherein the bolts are terminated at the rear-end of the switch housing.

A contact assembly comprised of a pair of semi-stationary contacts such as semi-stationary contacts 34 and 36 are positioned between each adjacent pair of insulator plates. Since this type of construction is well known in the art, it will not be discussed more fully hereinafter. It is sufficient to understand that each of the contact pairs on the interior of the switch are positioned to cooperate with rotatable contact elements such as contact elements 38 and 40 which are mounted on insulating discs 42 and 44 and are rotatable on shaft 46.

Thus, when the shaft 46 is rotated, contacts 38 and 40 which may be shaped as rotatable contact 48 of Figures 1 and 2 move protruding contact lobes into engagement with a respective semi-stationary contact positioned in the same plane as the plane which contains the rotatable contact.

Each of the semi-stationary contacts as best seen in Figures 1 and 2 are comprised of contact fingers 34 and 36. Each of the contact fingers have slots such as slots 50 and 52 therein which slots cooperate with protrusions 54 and 56 respectively of the stationary terminals 58 and 60 respectively. Stationary terminals 58 and 60 are then rigidly held within the molded switch casing as is seen in Figure 1 and in view of the cooperation between slots 50 and 52 of contact fingers 34 and 36 protrusions 54 and 56, contact fingers 34 and 36 are removably and pivotally mounted with respect to the switch housing.

Each of the contact fingers 34 and 36 are further provided with protrusions 62 and 64 which extend within the inner diameter of biasing springs 66 and 68 respectively. The other end of biasing springs 66 and 68 then bear against the molded switch housing so as to exert a biasing force on the spring fingers 34 and 36 which tends to drive their upper ends toward one another.

In the above description, it is to be understood that this is only one type of semi-stationary contact construction which could be utilized in a switch adapted with my novel invention. It is to be further understood that this construction may be standard for each section of the switch. That is to say, the same type of contact construction may be used for the switch members positioned between each adjacent insulator plate 20, 22, 24, 26 and 28.

A further standard component for the switch is the above described rotatable contact element 48 of Figure

2. This contact element in the illustrative embodiment of my invention is comprised of circular contact body having protruding contact lobes 70 and 72. The rotatable contact element is held within an insulating casing 74 which has notches 76 and 78 therein for receiving each of lobes 70 and 72 respectively. The retaining disc 80 is then pressed on top of the contact element 48 to rigidly retain it within casing 74.

In order to rotate contact element 48 so that lobes 70 and 72 may be brought into engagement with respect to their semi-stationary contacts, the inner diameter of casing 74 is knurled as at numeral 82. This knurled section cooperates with a corresponding knurl on shaft 46 to secure the shaft to the casing. Clearly, however, shaft 46 could be secured to the base of casing 74 in any desired manner.

Each of the normally used contact elements of the switch of Figure 1 are operated into and out of engagement responsive to the rotation of a single shaft 46. If, within the single switch unit, it is desired to move certain of the contact elements to the engaged position and at the same time move others to a disengaged position, then it is only necessary to angularly displace the position of the lobes of the contact elements with respect to one another.

Because of the inherent properties of a rotatable type switch unit such as the one described above, it has not been possible to have any one of the contact elements perform a momentary make operation only once throughout a complete switch operating cycle. That is, it is possible to displace one particular contact with respect to the others so that when the switch shaft 46 is rotated to a first position, the contact will sweep past its cooperating stationary contacts for a first make operation. When, however, the rotatable shaft 46 is rotated in the opposite direction to complete the switch operating cycle, the momentary contact will make once again to thereby re-energize the momentary make circuit which in many applications would be prohibitive.

The essence of the instant invention is to provide a construction which would allow only the first make operation but would prevent the second make operation when the switch is rotated to complete the switch operating cycle.

My novel invention may be applied to the above described standard switch unit by the mere addition of a single momentary contact adaptor 84 which is comprised of a cylindrical member having flattened side portions 86 and 88 and slotted portions 90 and 92. Ring 84 which is preferably of insulating material has an outside diameter which is larger than the distance from the ends of the two lobes 70 and 72 while the depth of notches 90 and 92 are substantially equal in depth to the thickness of contact lobes 70 and 72 in an axial direction. The inner diameter of ring 84 is then large enough to receive the outer diameter of casing 74 in a rotatable manner with the inner surfaces of lobes 70 and 72 riding on the outer surfaces of notches 90 and 92 respectively.

Accordingly, when shaft 46 is rotated, the contact ring 48 will rotate independently of ring 84 until lobes 70 and 72 pick-up the shoulders of notches 90 and 92 at which time ring 84 will rotate with contact ring 48 and shaft 46.

The operation of my novel adaption unit may be best understood with reference to Figures 3, 4, 5 and 6 which show a front view of the switch of Figures 1 and 2 in various operating positions.

Figure 3 shows the switch of Figure 1 at the beginning of its operating cycle where the momentary make contact lobes 70 and 72 are in a disengaged position with respect to semi-stationary contacts 34 and 36. The semi-stationary contacts 34 and 36 in this position are biased against flat sections 86 and 88 of my novel adaptor disc 84 and at this point shaft 46 is rotated in a counter-clockwise direction to begin the switch operating cycle.

It is to be clearly noted that at this point, contact lobes 70 and 72 bear against shoulders 94 and 96 respectively and notches 90 and 92 respectively.

When the shaft 46 is rotated in counter-clockwise direction, lobes 70 and 72 move into engagement with respect to semi-stationary contacts 34 and 36 as seen in Figure 4. Thus, a current path is set up from stationary terminal 58, contact finger 34, contact lobe 70, ring 48, contact lobe 72, contact finger 36 and stationary terminal 60. Accordingly, a circuit connected in series with stationary terminals 58 and 60 will be energized.

As the switch shaft 46 continues to be rotated in a counter-clockwise direction as shown in Figure 4 to place the other operation switch contacts in their desired position, the ring adaptor 84 of Figure 4 will be moved to the position shown in Figure 5 since when in the position of Figure 4, the contact lobes 70 and 72 pick-up shoulders 98 and 100 respectively to ring 84 to cause ring 84 to rotate with shaft 46. Accordingly, when the switch reaches the end of the first half of the operating cycle, the adaptor ring 84 will have been rotated to the position of Figure 5 where the semi-stationary contact members 34 and 36 are pressed outwardly and against the biasing action of biasing springs 66 and 68 to a position where contact engagement with respect to lobes 70 and 72 would be impossible if the lobes were in a horizontal and an engageable position.

At this time, the other various contact elements of the switch unit have been moved to their desired make or break position. When it is desired to reverse the switch action and to complete the second half of the switch operating cycle, it is now desired to prevent the momentary make contact operation.

This is achieved as seen when going from the position of Figure 5 to the position of Figure 6 where the contact lobes 70 and 72 are free to rotate within notches 90 and 92 respectively until they reach at least the horizontal and contact engageable position. However, since in going from the position of Figure 5 to the position of Figure 6, the rotatable contact moves independently of adaptor disc 84, the outer diameter of adaptor disc 84 remains in engagement with semi-stationary contacts 34 and 36 to prevent a contact engagement between the contact lobes 70 and 72 and the stationary contacts 34 and 36. Accordingly, the momentary make operation during the second half of the operating cycle is prevented.

The operating cycle is then continued and returns the switch from the position of Figure 6 to the position of Figure 3 by continued clockwise rotation with the contact lobes 70 and 72 picking-up shoulders 94 and 96 respectively to rotate adaptor disc 84 back to its initial position thus allowing the semi-stationary contacts to return to their engaging position.

The primary feature of my novel invention as above described is that a single unit such as adaptor disc 84 may be easily applied to an existing switch unit and thus provide a contact element which performs a momentary make operation only one time within a complete operating cycle.

As described above, the momentary make is achieved in the middle of the first half cycle of switch operation. However, it is obvious to anyone skilled in the art that the point of momentary make operation can be easily controlled by adjusting the initial position of disc 84 and the relationship between notches 90 and 92 and flats 86 and 88.

In the foregoing, I have described my invention only in connection with preferred embodiments thereof. Many variations and modifications of the principles of my invention within the scope of the description herein are obvious. Accordingly, I prefer to be bound not by the specific disclosure herein but only by the appending claims.

I claim:

1. In a switch device having a plurality of axially arranged pairs of stationary and rotatably movable contacts; each of said rotatably movable contacts being rotatably movable into and out of engagement with their said respective stationary contact; one of said pairs of stationary and rotatable contacts being constructed to have a momentary make once throughout the switch operating cycle; said momentary make stationary contact being movable from a contact engaging position to a contact disengaged position; said momentary make rotatable contact having an adaptor member associated therewith and rotatable with respect thereto for at least a portion of the rotation of said rotatable contact; said adaptor member being positionable by a predetermined rotation of said momentary make rotatable contact to operatively engage said momentary make stationary contact to move said momentary make stationary contact to its said contact disengaged position to thereby defeat contact engagement between said momentary make stationary and rotatable contacts.

2. In a switch device having a plurality of axially arranged pairs of stationary and rotatably movable contacts; each of said rotatably movable contacts being rotatably movable into and out of engagement with their said respective stationary contact; one of said pairs of stationary and rotatable contacts being constructed to have a momentary make once throughout the switch operating cycle; said momentary make stationary contact being movable from a contact engaging position to a contact disengaged position; said momentary make rotatable contact having an adaptor member associated therewith and rotatable therewith for at least a portion of the rotation of said rotatable contact; said adaptor member being positionable by a predetermined rotation of said momentary make rotatable contact to operatively engage said momentary make stationary contact to move said momentary make stationary contact to its said contact disengaged position to thereby defeat contact engagement between said momentary make stationary and rotatable contacts; said momentary make rotatable contact initially rotating independently of said adaptor member and engaging said momentary make stationary contact and thereafter moving said adaptor member to move said momentary make stationary contact to said contact disengaged position; said momentary make rotatable contact being thereafter incapable of re-engaging said momentary make stationary contact when the switch cycle is completed by moving said momentary make rotatable contact past said momentary make stationary contact a second time.

3. A momentary make contact arrangement for achieving momentary make between a semi-stationary contact and a rotatable contact once in a switch cycle; said semi-stationary contact having an engaging and disengaged position; said rotatable contact being rotatable into engagement with respect to said semi-stationary contact when said semi-stationary contact is in said engaging position; an adaptor member constructed to be rotated responsive to a predetermined rotation of said rotatable contact; said adaptor member being rotatable into engagement with said semi-stationary contact to move said semi-stationary contact to said disengaged position; rotation of said rotatable contact in a first direction being independent of said adaptor member until said rotatable contact engages said semi-stationary contact and thereafter moving said adaptor member into said operative engagement with said semi-stationary contact to move said semi-stationary contact to said disengaged position; said rotatable contact moving said adaptor member from said operative engagement with said semi-stationary contact when said rotatable contact is moved in an opposite direction and after said rotatable contact is moved past said semi-stationary contact.

4. A momentary make contact arrangement for achieving momentary make between a semi-stationary contact

and a rotatable contact once in a switch cycle; said semi-stationary contact having an engaging and disengaged position; said rotatable contact being rotatable into engagement with respect to said semi-stationary contact when said semi-stationary contact is in said engaging position; an adaptor member constructed to be rotated responsive to a predetermined rotation of said rotatable contact; said adaptor member being rotatable into engagement with said semi-stationary contact to move said semi-stationary contact to said disengaged position; rotation of said rotatable contact in a first direction being independent of said adaptor member until said rotatable contact engages said semi-stationary contact until said rotatable and semi-stationary contacts engage and thereafter moving said adaptor member into said operative engagement with said semi-stationary contact to move said semi-stationary contact to said disengaged position; said rotatable contact moving said adaptor member from said operative engagement with said semi-stationary contact when said rotatable contact is moved in an opposite direction and after said rotatable contact is moved past said semi-stationary contact; said adaptor member comprising a disc having an outer radius larger than the radius of said rotatable contact; said disc having flattened sides with notches therein; said rotatable contact being freely rotatably movable within said notch and picking-up said disc for rotation therewith when said rotatable contact engages on shoulder of said notch; said outer radius and said flattened portion of said disc being engageable with said semi-stationary contact to move said semi-stationary contact to said disengaged and engaging position respectively.

5. A momentary make contact arrangement for achieving momentary make between a semi-stationary contact and a rotatable contact once in a switch cycle; said semi-stationary contact having an engaging and disengaged position; said rotatable contact being rotatable into engagement with respect to said semi-stationary contact when said semi-stationary contact is in said engaging position; an adaptor member constructed to be rotated responsive to a predetermined rotation of said rotatable contact; said adaptor member being rotatable into engagement with said semi-stationary contact to move said semi-stationary contact to said disengaged position; rotation of said rotatable contact in a first direction being independent of said adaptor member until said rotatable contact engages said semi-stationary contact until said rotatable and semi-stationary contacts engage and thereafter moving said adaptor member into said operative engagement with said semi-stationary contact to move said semi-stationary contact to said disengaged position; said rotatable contact moving said adaptor member from said operative engagement with said semi-stationary contact when said rotatable contact is moved in an opposite direction and after said rotatable contact is moved past said semi-stationary contact; said adaptor member comprising a disc having an outer radius larger than the radius of said rotatable contact; said disc having flattened sides with notches therein; said rotatable contact being freely rotatably movable within said notch and picking-up said disc for rotation therewith when said rotatable contact engages one shoulder of said notch; said outer radius and said flattened portion of said disc being engageable with said semi-stationary contact to move said semi-stationary contact to said disengaged and engaging position respectively; said semi-stationary contacts being biased into engagement with said outer radius and said flattened portion of said disc.

6. In a switch device having a plurality of axially arranged pairs of stationary and rotatably movable contacts; each of said rotatably movable contacts being rotatably movable into and out of engagement with their said respective stationary contact; one of said pairs of stationary and rotatable contacts being constructed to have a momentary make once throughout the switch operating cycle; said momentary make stationary contact being

7

movable from a contact engaging position to a contact disengaged position; said momentary make rotatable contact having an adaptor member associated therewith and rotatable therewith for at least a portion of the rotation of said rotatable contact; said adaptor member being positionable by a predetermined rotation of said momentary make rotatable contact to operatively engage said momentary make stationary contact to its said contact disengaged position to thereby defeat contact engagement between said momentary make stationary and rotatable contacts; said adaptor member comprising a disc having an outer radius larger than the radius of said rotatable contact; said disc having flattened sides with notches therein; said rotatable contact being freely rotatably movable within said notch and picking up said disc for rotation therewith when said rotatable contact engages one shoulder of said notch; said outer radius and said flattened position of said disc being engageable with said semi-stationary contact to move said semi-stationary contact to said disengaged and engaging position respectively.

7. In a switch device having a plurality of axially arranged pairs of stationary and rotatably movable contacts; each of said rotatably movable contacts being rotatably movable into and out of engagement with their said respective stationary contact; one of said pairs of stationary and rotatable contacts being constructed to have a momentary make once throughout the switch operating cycle; said momentary make stationary contact being movable from a contact engaging position to a contact disengaged position; said momentary make rotatable contact having an adaptor member associated therewith and rotatable therewith for at least a portion of the rotation of said rotatable contact; said adaptor member being positionable

8

by a predetermined rotation of said momentary make rotatable contact to operatively engage said momentary make stationary contact to its said contact disengaged position to thereby defeat contact engagement between said momentary make stationary and rotatable contacts; said momentary make rotatable contact initially rotating independently of said adaptor member and engaging said momentary make semi-stationary contact and thereafter moving said adaptor member to move said momentary make semi-stationary contact to said contact disengaging position; said momentary make rotatable contact being thereafter incapable of re-engaging said momentary make semi-stationary contact when the switch cycle is completed by moving said momentary make rotatable contact past said momentary make stationary contact a second time; said adaptor member comprising a disc having an outer radius larger than the radius of said rotatable contact; said disc having a flattened side and a notch therein; said rotatable contact being freely rotatable movable within said notch and picking-up said disc for rotation therewith when said rotatable contact engages one shoulder of said notch; said outer radius and said flattened portion of said disc being engageable with said semi-stationary contact to move said semi-stationary contact to said disengaged and engaging position respectively.

References Cited in the file of this patent

UNITED STATES PATENTS

1,366,994 Winters et al. ----- Feb. 1, 1921
 1,905,228 James ----- Apr. 25, 1933

FOREIGN PATENTS

314,121 Switzerland ----- July 14, 1956