



- (51) **International Patent Classification:**
A61B 17/17 (2006.01) *A61F 2/46* (2006.01)
- (21) **International Application Number:**
PCT/EP2012/067025
- (22) **International Filing Date:**
31 August 2012 (31.08.2012)
- (25) **Filing Language:** English
- (26) **Publication Language:** English
- (30) **Priority Data:**
11179923.5 2 September 2011 (02.09.2011) EP
61/530,497 2 September 2011 (02.09.2011) US
- (71) **Applicant (for all designated States except US):** EPIS-
URF MEDICAL AB [SE/SE]; Stora Skuggans väg 11, S-
115 42 Stockholm (SE).
- (72) **Inventors; and**
- (75) **Inventors/Applicants (for US only):** BAKE, Nina
[SE/SE]; Elinshällsvägen 19, S-181 90 Lidingö (SE).
JOHNSSON, Anette [SE/SE]; Observatoriegatan 62, S-
554 48 Jönköping (SE). LUNDIN, Camilla [SE/SE];
Klереbovägen 53 Blomdala, S-564 91 Bankeryd (SE). JO-
HANSSON, Niklas [SE/SE]; Gelbgjutargatan 18A, S-553
23 Jönköping (SE). KARLSSON, Dan [SE/SE]; Linneg-

atan 14, S-554 54 Jönköping (SE). COLLNER, Måns
[SE/SE]; Hallmansvägen 20, S-554 48 Jönköping (SE).
AXELSSON, Robert [SE/SE]; Högaberg 30, S-563 91
Gränna (SE).

(74) **Agent:** KITZLER, Michael; P.O. Box 42, S-683 21 Hag-
fors (SE).

(81) **Designated States (unless otherwise indicated, for every
kind of national protection available):** AE, AG, AL, AM,
AO, AT, AU, AZ, BA, BB, BG, BH, BN, BR, BW, BY,
BZ, CA, CH, CL, CN, CO, CR, CU, CZ, DE, DK, DM,
DO, DZ, EC, EE, EG, ES, FI, GB, GD, GE, GH, GM, GT,
HN, HR, HU, ID, IL, IN, IS, JP, KE, KG, KM, KN, KP,
KR, KZ, LA, LC, LK, LR, LS, LT, LU, LY, MA, MD,
ME, MG, MN, MW, MX, MY, MZ, NA, NG, NI,
NO, NZ, OM, PE, PG, PH, PL, PT, QA, RO, RS, RU, RW,
SC, SD, SE, SG, SK, SL, SM, ST, SV, SY, TH, TJ, TM,
TN, TR, TT, TZ, UA, UG, US, UZ, VC, VN, ZA, ZM,
ZW.

(84) **Designated States (unless otherwise indicated, for every
kind of regional protection available):** ARIPO (BW, GH,
GM, KE, LR, LS, MW, MZ, NA, RW, SD, SL, SZ, TZ,
UG, ZM, ZW), Eurasian (AM, AZ, BY, KG, KZ, RU, TJ,
TM), European (AL, AT, BE, BG, CH, CY, CZ, DE, DK,
EE, ES, FI, FR, GB, GR, HR, HU, IE, IS, IT, LT, LU, LV,
MC, MK, MT, NL, NO, PL, PT, RO, RS, SE, SI, SK, SM,

[Continued on next page]

(54) **Title:** MODULAR SURGICAL KIT FOR CARTILAGE REPAIR

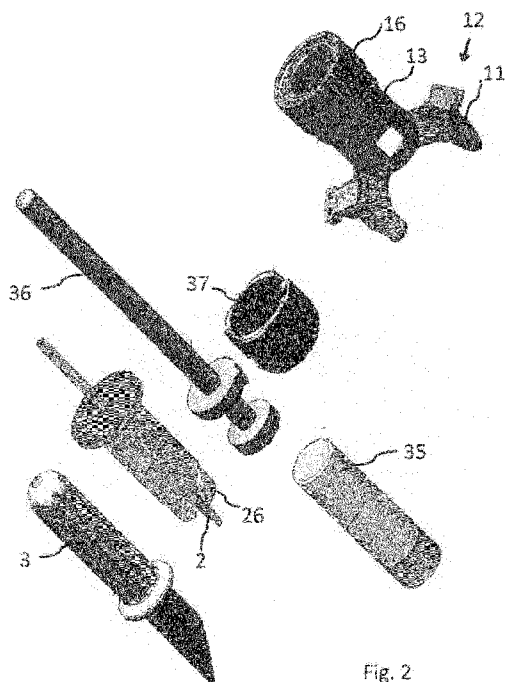

Fig. 2

(57) **Abstract:** This invention relates a modular surgical kit for repair of diseased cartilage at an articulating surface of a joint. This invention also includes a designmethod for a modular surgical kit. The modular surgical kit is adapted for removal of damage cartilage and bone and also adapted for insertion of a medical implant a grafted plug or an artificial plug having an implant body with a predetermined cross-sectional profile and adapted for guiding insert tools during repair of diseased cartilage at an articulating surface of a joint, wherein the modular surgical kit comprising; an implant, and a medical implant a grafted plug or an artificial plug having an implant body with a predetermined cross-sectional profile a guide base having a positioning body with a guide hole through said positioning body and wherein: the modular surgical kit comprises a drill adjustment device being arranged to enable adjustment of the drill depth e.g. in certain length intervals the positioning body has a cartilage contact surface that is designed to fit the contour of cartilage or subchondral bone in the joint in a predetermined area surrounding the site of diseased cartilage the guide hole has a muzzle on the cartilage contact surface at a position corresponding to the site of the diseased cartilage; and a guide body with a guide channel, the guide channel having a cross-sectional profile that is designed to correspond to the cross-sectional profile of the implant body and having a muzzle; wherein the positioning body comprises means for releasably connecting to the guide body such that, when connected, the guide channel is positioned in relation to the positioning body such that its muzzle emanates at a site corresponding to the site of implantation into the bone.



TR), OAPI (BF, BJ, CF, CG, CI, CM, GA, GN, GQ, GW, ML, MR, NE, SN, TD, TG).

— before the expiration of the time limit for amending the claims and to be republished in the event of receipt of amendments (Rule 48.2(h))

Published:

— with international search report (Art. 21(3))

Modular surgical kit for cartilage repair

Field of the invention

This invention relates in general to the field of orthopedic surgery and to surgery kits, kits of tools and medical implants. More particularly the present invention relates to a
5 modular surgical kit comprising a guide base and a guide body for use with a set of surgical tools. The surgical kit is to be used for replacement or repair of damaged cartilage at an articular surface in a joint such as a knee, hip, toe and shoulder.

Background

General background

10 Pain and overuse disorders of the joints of the body are a common problem. For instance, one of the most important joints which are liable to wearing and disease is the knee. The knee provides support and mobility and is the largest and strongest joint in the body. Pain in the knee can be caused by for example injury, arthritis or infection. The weight-bearing and articulating surfaces of the knees, and of other joints, are covered with a layer of soft
15 tissue that typically comprises a significant amount of hyaline cartilage. The friction between the cartilage and the surrounding parts of the joint is very low, which facilitates movement of the joints under high pressure. The cartilage is however prone to damage due to disease, injury or chronic wear. Moreover it does not readily heal after damages, as opposed to other connective tissue, and if healed the durable hyaline cartilage is often
20 replaced by less durable fibrocartilage. This means that damages of the cartilage gradually become worse. Along with injury/disease comes a problem with pain which results in handicap and loss of function. It is therefore important to have efficient means and methods for repairing damaged cartilage in knee joints.

Today's knee prostheses are successful in relieving pain but there is a limit in the lifetime
25 of the prostheses of 10-15 years. The surgical operation is demanding and the convalescence time is often around 6-12 months. In many cases today, surgery is avoided if training and painkillers can reduce the pain. Prostheses are therefore foremost for elderly patients in great pain, at the end of the disease process; a totally destroyed joint. There are different kinds of prostheses, such as half prosthesis, total prosthesis and
30 revision knee, the latter used after a prosthesis failure. The materials used in today's knee prostheses are often a combination of a metal and a polymeric material, but other materials such as ceramics have also been used. The size of knee prostheses makes it necessary to insert them through open surgery.

Other attempts practiced at various clinics around the world with the main objective to repair or rebuild cartilage include biological approaches such as micro fractures, cartilage cell transplantation (ACI), periosteal flap, and mosaic plasty surgery. In mosaicplasty surgery
5 grafts, in the form of plugs or dowels of healthy cartilage and underlying bone are harvested from nonbearing parts of the joint i.e. areas of low stress in the joint. Such plugs may be denoted osteochondral plugs. In related surgical techniques similarly shaped plugs as those of mosaicplasty, but made of artificial material, may be used. The plugs or dowels are inserted into drill holes made at the diseased or damaged site, such that they form a
10 mosaic pattern of healthy cartilage at the surface of the joint. Osteochondral autograft transfer (OATS) is a technique similar to mosaicplasty but during the OATS procedure the plugs are usually larger, and therefore only one or two plugs are needed to fill the area of cartilage damage. A difficulty with both mosaicplasty and OATS is to make sure that the plugs are inserted such that they form an even surface. If the plugs are offset from their
15 intended position, e.g. such that they are tilted or project over the surrounding cartilage tissue, they may cause increased wear and load on the joint, resulting in more pain for the patient. The biological treatments have shown only limited results this far, with implications such as high cost, risk of infection, risk of loosening, limited suitability for patients of different ages and the extent and location of damage. They do however have
20 many advantages, especially for young patients who still are growing and who have better abilities for self-repair, if these difficulties can be overcome.

The advantages of implants have stimulated a further development of smaller implants that can be implanted with less invasive surgery. In this development there has also been an effort to achieve small joint implants, suitable for repair of a small cartilage injury that
25 have a minimal influence on the surrounding parts of the joint. In the current development, such small implants are designed with an implant body that may be formed as a thin plate with a hard surface for facing the articulate side of the joint and a bone contacting surface for facing the bone below the damaged part of cartilage. The shape and the curvature of the articulate surface of the implant may be designed to be similar to the
30 shape and the curvature of the part of the joint where the implant is inserted. Such implants are designed as mushrooms with an implant body or head and optionally with a peg or a rod projecting from the bone contacting side of the implant body for fastening the implant to the bone.

In the surgical operation of implanting small implants, including grafted plugs or artificial
35 plugs used for mosaicplasty or OATS, it is critical that the implant is positioned in a precise manner. If the implant is offset from its intended position it may cause increased

wear or load on the joint. For example, if the implant is tilted this may result in an edge that projects above the cartilage surface and causes wear on the opposing cartilage in the joint. Another example is when the implant is placed in a position with the surface of the implant projecting above the surface of the cartilage causing the joint to articulate in an
5 uneven manner and increasing the load on an opposing point of the joint. For the patient, also small misplacements or deviations from an ideal position may result in pain, longer time for convalescence or even a surgical operation being done in vain and making it more difficult to repair the damage in the joint. A large burden is therefore placed on the surgeon not to misplace or misfit the implant. In order to support the surgeon during the
10 implant surgery and to improve the positioning of the implant various tools and guides that support the surgical procedure have been developed.

Specific background

Some of the surgical tools developed for implant surgery include guide tools having a channel or similar through which the surgical tools and/or the implant are guided
15 throughout the surgery. Often these guide tools are rather bulky and placed over the damaged site of the cartilage such that it is difficult for the surgeon to see the site of implantation during surgery. Also it may be difficult to remove debris and waste that is generated at the implantation site during surgery. In order for the surgeon to be able to inspect the implantation site and/or remove such surgery the guide tool has to be removed
20 from the surgical site in the joint. There is a need for a surgical kit for replacement or repair of damaged cartilage at an articular surface in a joint that guides the surgeon, improves the positioning of the implant or the grated or artificial plugs used for mosaicplasty or OATS, and that facilitates inspection of the implantation site and removal of debris during surgery.

25

Prior art

Examples of prior art disclosing smaller implants and tools for replacement of damaged cartilage are shown in:

WO2007/014164 A2 describes a kit comprising a plurality of small joint implants having
30 different predetermined shapes described as circular, oval, L-shaped and triangular and tools for placing the implants and a method for placing the implant in a joint, e.g. in the knee or other joints where there is a need for repair of a cartilage and/or bone damage. In this piece of prior art each implant shape has a specific guide tool which corresponds to the shape of the implant.

The cartilage damage is repaired by choosing the most suitable implant from the different shapes mentioned above. The corresponding guide tool is selected and is used for faster reaming of the area where the implant is to be placed. A drill is used for drilling a hole to accept the post extending from the bone contacting side of the implant. In the end, the
5 implant is placed on the area reamed or drilled out for the implant. Although it is the intention that the guide tool shall be used for the preparation of the placement of the implant it is also said that the use of the guide tool is optional, see passage sections [019, 020].

US20030216669 A1 describes methods and compositions for producing articular repair
10 material used for repairing an articular surface. The method for designing an articular implant comprises; taking an image of the joint, reconstructing dimensions of the diseased cartilage surface to correspond to normal cartilage and designing the medical implant accordingly. This prior art also shows a surgical assistance device or surgical tool for preparing the joint to receive an implant. The surgical tool comprises of one or more
15 surfaces or members that conform to the shape of the articular surfaces of the joint. It can include apertures, slots and/or holes that can accommodate surgical instruments such as drills and saws. (see claim 18, [0029], [175] fig 13, 15, 16), and thus may also be designed and used to control drill alignment, depth and width, for example when preparing a site to receive an implant [0179]. The tool may be single-use or reusable [181]. These surgical
20 tools (devices) can also be used to remove an area of diseased cartilage and underlying bone or an area slightly larger than the diseased cartilage and underlying bone [0182].

EP 1 698 307 A1 discloses an instrument for removing cartilage and introducing an implantable nonwoven into cartilage. The instrument may further comprise a cartilage puncher having a channel through which further instruments, such as surgical spoons or
25 curettes, can be guided to the cartilage defect ([0028-0029]).

WO2008098061 A2 also describes examples of small articular surface implants and tools for placement of the implants. The tools and the implant are used to repair damaged articular cartilage areas.

Wo2006091686 A2 describes a small implant for replacing a portion of an articular
30 surface (see the abstract). The implant is placed using a rotating excision tool (see page 8 line 25) and the implant is selected from a set (see page 10 line 22-23).

WO 2009111626 describes implants for altering wear patterns of articular surfaces of joints (see [00190]) and a device and a method for repair of articular surfaces, in for example a knee. The implants and methods may replace all or a portion of the articular
35 surface and achieve an anatomic or near anatomic fit with the surrounding structures and

tissues, the techniques described herein allow for the customization of the implant to suit a particular subject, the implant is a mirror image of the articular surface, see[0057]-[0058]. The implants are selected from predetermined shaped and their location can be optimized for the patients wear pattern and the wear patterns are assessed by for example MRI [0061]-[0063], [0072]. The tools used for placement of the implants are selected depending on MRI images but not created depending on the images [00211].

WO2008101090 A2 describes a method for making a large implant suitable for a joint. The 3D surface of the joint implant is determined using MRI or CT depicting the damaged that is to be repaired.

10 US2006/0198877 A1 describes a medical instrument for autologous chondrocyte transplantation.

WO2009/108591 A1 describes s a method and tools for repairing an articular cartilage defect and also an implant.

15 US6306142B1 describes a system and tools for transplanting a bone plug from a donor site to a recipient site.

US 2003/0100947 A1 describes a device for repairing articular cartilage defects.

Object of the Invention

General object

20 The general object of the invention is to solve the problem of providing means that aid the implantation of a cartilage replacement implant, including grafted or artificial plugs used for mosaicplasty or OATS, into the articular surface of a joint, aiding and facilitating the work for the surgeon and improving the positioning of the implant in order to generate optimal repair of damaged tissue and cause minimum damage to the surrounding tissue.

25 *Partial problems*

The invention further seeks to solve the partial problems of facilitating inspection of the implantation site and removal of debris during surgery.

Summary of the invention

The present invention provides a modular surgical kit comprising a guide base and a guide body for use with a set of tools and a method for replacing a portion, e.g. diseased area and /or area slightly larger than the diseased area, of a joint, e.g. cartilage and/or bone, with an implant or with one or more artificial or grafted bone and cartilage plugs, such as those used for mosaicplasty or OATS. The modular surgical kit may also comprise the set of tools. The modular surgical kit is arranged to achieve a near anatomic fit of the implant with the surrounding structures and tissues as well as facilitating the surgical procedure.

10 A modular surgical kit according to the invention is adapted for removal of damage cartilage and bone and also adapted for insertion of a medical implant 10, a grafted plug 600 or an artificial plug having an implant body 27, 627 with a predetermined cross-sectional profile 81 and adapted for guiding insert tools during repair of diseased cartilage at an articulating surface of a joint, wherein the modular surgical kit comprising;

15 an implant, and a medical implant 10, a grafted plug 600 or an artificial plug having an implant body 27, 627 with a predetermined cross-sectional profile 81 a guide base 12 having a positioning body 11 with a guide hole 53 through said positioning body 11, wherein:

20 the modular surgical kit comprises a drill adjustment device 16 being arranged to enable adjustment of the drill depth e.g. in certain length intervals

the positioning body 11 has a cartilage contact surface 50 that is adapted or designed to fit the contour of cartilage or subchondral bone in the joint of a patient in a predetermined area surrounding the site of diseased cartilage

25 the guide hole 53 has a muzzle 29 on the cartilage contact surface 50 at a position corresponding to the site of the diseased cartilage; and

a guide body 13 with a guide channel 54, the guide channel 54 having a cross-sectional profile that is designed to correspond to the cross-sectional profile 81 of the implant body 27, 627 and having a muzzle 32;

30 wherein

the positioning body 11 comprises means for releasable connecting 47 to the guide body 13 such that, when connected, the guide channel 54 is positioned in relation to the positioning body 11 such that its muzzle 32 emanates at a site corresponding to the site of implantation into the bone.

35

The present invention provides a modular surgical kit for repair of diseased cartilage at an articulating surface of a joint. It is for use with a medical implant, a grafted plug, or an artificial plug that has an implant body with a predetermined cross-sectional profile. The modular surgical kit comprises a guide base with a positioning body and a guide hole
5 through the positioning body. The positioning body has a cartilage contact surface that is designed to fit the contour of cartilage or subchondral bone in the joint in a predetermined area surrounding the site of diseased cartilage. The guide hole has a muzzle on the cartilage contact surface at a position corresponding to the site of the diseased cartilage.

The modular surgical kit further comprises a guide body with a guide channel. The guide
10 channel has a cross-sectional profile that is designed to correspond to the cross-sectional profile of the implant body and also has a muzzle.

Furthermore, the guide base, e.g. the positioning body comprises means for releasably connecting to the guide body. When connected, the guide channel is positioned in relation to the positioning body such that its muzzle emanates at a site corresponding to the site of
15 implantation into the bone.

In one embodiment of the modular surgical kit the cartilage contact surface is custom designed to fit the contour of the cartilage or subchondral bone of a specific patient. In another embodiment the cartilage contact surface is designed to fit the contour of the cartilage or subchondral bone of an average patient.

20 In one embodiment of the modular surgical kit, for use e.g. in mosaicplasty or OATS surgery, the guide body comprises at least two guide channels. Each guide channel has a cross-sectional profile that is designed to correspond to the respective cross-sectional profile of at least two implant bodies.

In a further embodiment of the modular surgical kit the guide channel, having a cross-
25 sectional profile that is designed to correspond to the cross-sectional profile of the implant body, is provided by a guide insert that is designed to fit in the guide body.

In still another embodiment the modular surgical kit further comprises a drill adjustment device that is arranged to enable adjustment of the drill depth e.g. in certain length intervals.

30 In one embodiment the positioning body is arranged with at least one breakage means for enabling easy removal of part of the positioning body by tearing, fracturing or similar breakage. Such means may for example be provided by grooves, slots or perforations or other weakening of the structure.

The positioning body may also be arranged with at least one attachment means for enabling easy attachment of adaptors, pins and other devices used during surgery, e.g. by snap fit. The modular kit may also further comprise adaptors that fit the attachment means, for enabling flexible attachment of pins and other devices.

- 5 In one embodiment the modular surgical kit further comprises an insert tool with a cross-sectional profile that is designed to correspond to the cross-sectional profile of the guide channel, with a tolerance enabling the insert tool to slide within the guide channel.

Such insert tool may be a cartilage cutting tool that has a cross-sectional profile that is designed to correspond to the cross-sectional profile of the guide channel, with a tolerance
10 enabling the cartilage cutting tool to slide within the guide channel. The cartilage cutting tool comprises a cutting blade with sharp cutting edges that are able to cut the cartilage in a shape that substantially corresponds to the cross-section of the implant body.

The insert tool is in another embodiment a drill and bone remover having a drill and bone
15 remover body with a cross-sectional profile that is designed to correspond to the cross-sectional profile of the guide channel, with a tolerance enabling the drill and bone remover to slide within the guide channel. The drill and bone remover may comprise a central drill, for drilling a bore to receive the extending post of the implant, and a bone remover, for cutting a recess in the bone to receive the implant body of the implant.

The insert tool may further be a mandrel having a mandrel surface that is designed to fit
20 the articulate surface of the implant. The mandrel also has a cross-sectional profile that is designed to correspond to the cross-sectional profile of the guide channel, with a tolerance enabling the mandrel to slide within the guide channel.

In one embodiment the surgical kit further comprises an implant dummy having an
25 implant element that is designed to match the implant body and having a lower surface that is a replica of the bone contact surface of the implant, but comprising no extending post. The surgical kit may further comprise a dummy reference that is arranged to fit to, and possibly releasable attach to, the guide hole of the guide base. It is arranged to receive the implant dummy, by being provided with a channel.

In one embodiment the surgical kit according to the invention, further comprises a
30 positioning body which has a cartilage contact surface (50) that is designed or adapted to individually fit the contour of the cartilage or subchondral bone in the joint of a specific patient in a predetermined area surrounding the site of diseased cartilage

The method of designing a modular surgical kit for cartilage repair in an articulating surface of a joint according to the invention comprising the steps of:

I. Determining physical parameters for cartilage damage in a joint, comprising:

a. obtaining image data representing a three dimensional image of a bone member of the joint;

b. identifying in the image data a cartilage damage in an articulate surface of the bone member;

c. determining based on the image data the location of the cartilage damage;

d. determining based on the image data the size and shape of a cartilage damage;

e. determining based on the image data the surface contour curvature of the cartilage and/or the subchondral bone in the joint in a predetermined area comprising and surrounding the site of cartilage damage;

II. Generating design parameters for a medical implant (10) , a grafted plug (600) or an artificial plug, comprising the steps a-c in no specific order:

a. generating the contour curvature for an articulate surface of an implant body (27, 627) dependent on said determined surface curvature of the cartilage and/or the subchondral bone;

b. generating a cross-section for the implant body dependent on and substantially corresponding to said determined size and shape of the damaged cartilage or corresponding or generating a cross-section for the implant body (27, 627) together with another cross-section for another other implant (10) or grafted plug (600) or an artificial plug to said determined size and shape of the damaged cartilage by forming a pattern;

c. generating an edge height (14, 710) for the implant body (27, 627) that substantially corresponds to the thickness of healthy cartilage plus a selected height of a bone contacting part of the implant for countersinking the implant (10) , a grafted plug (600) or an artificial plug into a recess to be made in the bone to fit and receive the implant (10) , the grafted plug (600) or the artificial plug;

III. Generating design parameters of a guide tool for implanting said implant (10) or , a grafted plug (600) or an artificial plug comprising:

a. generating the contour curvature for a cartilage contact surface (50) of a positioning body (11) dependent on said determined surface contour curvature of the cartilage and/or the subchondral bone in the joint in a

predetermined area comprising and surrounding the site of cartilage damage, such that said cartilage contact surface (50) of the positioning body (11) corresponds to and fits to said surface contour of the cartilage or the subchondral bone in the joint;

- 5 b. generating the cross-section profile (82, 122) for a guide channel (54) in a guide body (13) extending from the positioning body (11), said guide channel (54) passing through said positioning body (11) and said guide body (13),
- 10 the cross-section profile (82, 122) for the guide channel (54) being generated dependent on and substantially corresponding to said determined size and shape of the damaged cartilage, and such that the guide channel (54) is designed to have a cross-sectional profile (82, 122) that corresponds to the cross-section (81, 121) the implant body (27, 627) or that corresponds to the combination of at least two cross-sections (81,
- 15 121) the implant body (27, 627), and such that the guide channel (54) is designed to have a muzzle (29) on the cartilage contact surface (50) of the positioning body (11) at a position corresponding to the site of the diseased cartilage;
- 20 c. generating the shape of the guide body (13) of guide tool, depending on the design of the positioning body (11) and wherein the guide body (13) is designed to be releasably attached to the positioning body (11);
- d. generating the cross-section profile (84, 124) for an insert tool to have a cross-sectional profile that corresponds to the cross-sectional profile (82) of the guide channel (54) with a tolerance enabling the insert tool to slide
- 25 within the guide channel (54); and
- wherein said steps III c. and III d. of said design method comprising steps I a-e, II a-c, III a-d. may be in any order, for example first III c. then III d. or first III d. then IIIc.

30 **Brief description of the figures**

The present invention will be further explained below with reference to the accompanying drawings, in which:

Fig. 1 shows a schematic overview of an exemplifying method used for designing a patient specific surgical kit.

Fig. 2 shows a surgical kit according to one embodiment of the invention, exemplified by a surgical kit for a knee, the surgical kit comprising a guide base, a guide body and a set of tools.

Fig. 3a-b shows an exemplifying embodiment of an implant to be used with the present invention. Fig. 3c shows exemplifying cross-sectional profiles of such implant.

Fig. 4a-b shows an exemplifying embodiment of a grafted plug to be used with the present invention. Fig. 4c shows exemplifying cross-sectional profiles of such grafted plug. Fig. 4d-e show such grafted plugs implanted into bone by use of mosaicplasty surgery.

Fig. 5a-d show exemplifying embodiments of a guide base according to the present invention, for use in a knee joint (a-b) and in a toe joint (c-d) respectively.

Fig. 6 shows an exemplifying embodiment of a modular surgical kit according to the present invention, for use in a knee joint.

Fig. 7 shows an exemplifying embodiment of a modular surgical kit according to the present invention, for use in a toe joint.

Fig. 8 shows an exemplifying embodiment of a guide body according to the present invention, for use in mosaicplasty surgery.

Fig. 9 shows an exemplifying embodiment of a cartilage cutter according to the invention.

Fig. 10 shows an exemplifying embodiment of a drill and bone remover according to the present invention.

Fig. 11a-b show exemplifying embodiments of a dummy reference (a) and an implant dummy (b) according to the present invention.

Fig. 12 shows an exemplifying embodiment of a mandrel according to the present invention.

Fig. 13 shows exemplifying embodiments of the cross-sectional profiles of an implant and tools of the modular surgical kit according to the present invention.

Fig. 14a-t shows an exemplifying embodiment of a method for implanting a cartilage implant using the modular surgical kit of the present invention.

Fig. 15 shows an exemplifying embodiment of a drill and bone remover according to the present invention.

Detailed description of the invention

Introduction

This invention concerns a surgical kit for use in orthopedic surgery. A surgical kit according to the invention comprises a set of tools for the implantation of an implant, or one or more grafted plugs or artificial plugs that replaces damaged cartilage in a joint.

Figure 2 shows a surgical kit according to one embodiment of the present invention, for use in repair of damaged cartilage in a knee joint. The surgical kit comprises tools that are adapted to an implant and to a joint; a guide base 12 with a positioning body 11 and, releasably attached thereto, a guide body 13. A drill adjustment device 16 fitting to the guide body 13 may also be included in the kit. Further the surgical kit may comprise insert tools, for example a cartilage cutting tool 3: a drill 2, in this exemplifying embodiment equipped also with a bone remover 26, an implant dummy 36, a dummy reference 37 and/or a mandrel 35. Optionally, the kit may also comprise the implant to be implanted by use of the surgical kit.

The implant and the set of tools according to the invention are preferably individually designed for a person's joint. The implant and the set of tools are also optionally individually designed for a specific person's cartilage individual injury.

Exemplifying embodiments of the invention are shown herein which are especially adapted for cartilage replacement at the femur of a knee joint and at the joint of a toe. The invention may however, also have other useful applications, such as for cartilage replacement at an articulating surface at any other joint in the body, e.g. elbow, ankle, finger, hip and shoulder.

The surgical kit

This invention provides a surgical kit where the successful implant insertion is less depending on the skills of the surgeon compared to previously known methods and which facilitates inspection of the surgical procedure as well as removal of wear and debris during the surgery. This invention provides preferably individually designed tools and implant. Due to the design and the function of both tools and implant the surgical kit gives improved implantation precision and a precise desired placement of the implant in the joint every time. The precision of the surgery is "built in" into the design of the tools.

The surgical kit of the invention leads to shorter learning curves for the surgeon since the surgical kit facilitates for quick, simple and reproducible surgery.

In one exemplifying embodiment the implant is intended for replacing damaged cartilage in a knee. The site where the implant is to be implanted according to the invention is an articular cartilage surface including, for example, the lateral femoral chondral (LFC) surfaces, medial femoral chondral (MFC) surfaces, trochlea surfaces, patella surfaces, tibia surfaces (e.g. surfaces of the tuberosities of the tibia), and combinations and portions thereof. For example implants may be placed on any one of these surfaces.

In another exemplifying embodiment the implant is intended for replacing damaged cartilage in a toe, for example on the cartilage surfaces between the metatarsals and the proximal phalanges bones in a toe.

In a further exemplifying embodiment the implant is intended for replacing damaged cartilage in a shoulder, for example on the articulation surfaces between the head of the humerus and the lateral scapula (specifically-the glenoid fossa of the scapula).

The implant is inserted through a small open surgery operation using a tool kit where the tools in the tool kits are preferably individually designed or tailor/custom made for the person who suffers from the injury. This leads to decreased suffering of the patient and is economically favorable since it leads to shorter convalescence time and less time for the patient at the hospital. By using this optionally individually designed surgery kit the implant insertion will be optimal and thus misalignment which is one of the problems associated with the common methods used today can be avoided.

Using the surgical kit according to the invention, small cartilage damages will require small implants and in this way combined with the design of the guide tool, a surgical operation with little tissue damage, a small open surgery, is needed for the person suffering from a knee injury. This gives the effect that minimal modifications on the underlying bone and surrounding tissue are required when preparing for the implant surgery. Using implants according to the present invention makes it possible to repair cartilage defects at a much earlier stage than previously. This early replacement of damaged cartilage may postpone or prevent osteoarthritis.

The object of the invention is to solve the problem of repairing damaged, injured or diseased cartilage in knees, toes, elbows or shoulders by providing an implant that will have better placement and thus a seamless placement in the cartilage.

The benefits from the implant according to the invention are relief from pain and swelling in the joint and also the restoration of a smooth, continuous articulating surface. The implant and the tool kit of the present invention also facilitates for the return to normal activity with rapid recovery time, possibility to postpone or avoid total knee replacement

surgery. A less traumatic surgery procedure is used and potentially faster recovery after surgery.

Implants for use with the present invention

5 The surgical kit of the present invention may be used for implantation of for example small implants and of bone and cartilage plugs, such as osteochondral plugs, or artificial plugs used in mosaicplasty or OATS. Examples of implants to be used with the surgical kit of the invention will be given below. The kit may however be used with any implant having an implant body with a cross-sectional profile that corresponds to the cross-sectional
10 profile the guide channel of the guide body 13 (see below).

Small implant

Fig. 3a- 3b shows an embodiment of a medical implant 10 that may be used with a surgical kit according to the present invention. The implant comprises an implant body 27 and an
15 extending post 23. The implant body 27 has an articulate surface (first surface) 15 configured to face the articulating part of the joint and a bone contact surface (second surface) 21 configured to face bone structure in the joint. An extending post 23 extends from the bone contact surface 21. Between the articulate surface 15 and the bone contact surface 21 there is a cartilage contacting surface 19.

20 The implant may be specially designed, depending on the appearance of the knee and the shape of the damage and in order to resemble the body's own parts, having a surface which preferably corresponds to a three dimensional (3D) image of a simulated healthy cartilage surface. The implant can thus be tailor-made to fit each patient's damaged part of the joint. Alternatively, the implant to be used with the present invention may be of
25 standard shapes and sizes.

Implant body

The implant body 27 is in one embodiment substantially plate shaped, meaning that the shortest distance (represented by 24 in figure 3a) crossing the surface 15 of the implant
30 body 27 is substantially larger, e.g. at least 1.5 times larger than the thickness 14 of the implant body 27. By substantially plate shaped is meant that the implant body 27 may be substantially flat or may have some curvature, preferably a 3D curvature of the articulate surface 15. The plate shaped implant body 27 has a cross-section 81 that substantially

corresponds to the area of the damaged cartilage, see figures 3c and 12a-b implant 10, with four exemplifying cross-sectional views, 81a-d. The articulate surface 15 of the plate shaped implant body 27 may have a curvature that substantially corresponds to the curvature of a healthy articulating surface at the site of diseased cartilage. The curvature may for instance correspond to a simulated healthy cartilage reconstructed from an image taken with MRI image or the CT-scanning of the damaged cartilage surface of the joint. Once the implant 10 is placed in the joint there will be a surface with no parts of the implant pointing up from or down below the surrounding cartilage- the implant is incorporated to give a smooth surface.

- 10 The size and the shape of the implant body 27 may be individually adapted, or may be chosen from a set of standards, dependent on the size of cartilage damage and location of the cartilage damage. The area and shape of the implant can be decided by the surgeon himself or be chosen from predetermined shapes. For instance the cross-section of the implant body 27 may have a circular or roughly circular, oval, triangular, square or
15 irregular shape, preferably a shape without sharp edges (see e.g. figures 3c and 13a-b, implant 10). The size of the implant 10 may also vary. The area of the articulate surface 15 of the implant varies in different realizations of the invention between 0.5 cm² and 20 cm², between 0.5 cm² and 15 cm², between 0.5 cm² and 10 cm², between 1 cm² and 5 cm² or preferably between about 0.5cm² and 5 cm².
- 20 In general, small implants are preferred since they have a smaller impact on the joint at the site of incision and are also more easily implanted using arthroscopy or smaller open surgical procedures. The primary factor for determining the size of the implant is however the nature of the lesion to be repaired.

The articulate surface 15 of the implant body 27, and the core of the implant body 27,
25 comprises a biocompatible metal, metal alloy or ceramic. More specifically it can comprise any metal or metal alloy used for structural applications in the human or animal body, such as stainless steel, cobalt-based alloys, chrome-based alloys, titanium-based alloys, pure titanium, zirconium-based alloys, tantalum, niobium and precious metals and their alloys. If a ceramic is used as the biocompatible material, it can be a biocompatible
30 ceramic such as aluminium oxide, silicon nitride or yttria-stabilized zirconia. Preferably the articulate surface 15 comprises a cobalt chrome alloy (CoCr) or stainless steel, diamond-like carbon or a ceramic. The articulate surface 15 and the core of the implant body 27 may comprise the same or different materials.

The articulate surface 15 may also be further surface treated in order to e.g. achieve an
35 even more durable surface or a surface with a lower friction coefficient. Such treatments

may include, for example, polishing, heat treatment, precipitation hardening or depositing a suitable surface coating.

The bone contact surface

5 The implant body 27 has a bone contact surface (bone contact surface) 21, configured to face or contact the bone structure of the joint. In one embodiment the bone contact surface 21 comprises a biocompatible metal, metal alloy or ceramic, such as any of the metals, metal alloys or ceramic described above for the articulate surface 15. Preferably the bone contact surface 21 comprises a cobalt chrome alloy (CoCr), a titanium alloy, titanium
10 or stainless steel.

In one embodiment the bone contact surface 21 comprises, or in one specific embodiment is coated with, a bioactive material. In an alternative embodiment of the invention the bone contact surface does not comprise a bioactive material and/or is uncoated.

The bioactive material of the bone contact surface, if present, preferably stimulates bone
15 to grow into or onto the implant surface. Several bioactive materials that have a stimulating effect on bone growth are known and have been used to promote adherence between implants and bone. Examples of such prior art bioactive materials include bioactive glass, bioactive ceramics and biomolecules such as collagens, fibronectin, osteonectin and various growth factors. A commonly used bioactive material in the field of
20 implant technology is the bioactive ceramic hydroxyapatite (HA), chemical formula $\text{Ca}_{10}(\text{PO}_4)_6(\text{OH})_2$. HA is the major mineral constituent of bone and is able to slowly bond with bone *in vivo*. HA coatings have been developed for medical implants to promote bone attachment. Another bioactive material commonly used in prior art is bioactive glass. Bioactive glasses, generally comprising SiO_2 , CaSiO_3 , P_2O_5 , Na_2O and/or CaO and possibly
25 other metal oxides or fluorides, are able to stimulate bone growth faster than HA.

The bioactive materials described above have an anabolic effect on the bone i.e. stimulates bone growth. The fixation of the implant can also be improved by decreasing the catabolic processes i.e. decrease the amount of bone resorption next to the implant. The bone contact surface 21 and/or the extending post can also be modified with bisphosphonates.
30 Bisphosphonates are substances that decrease the catabolic process of bone and binds readily to HA. One way to bind the bisphosphonate to the surface is by coating it with HA, which it readily binds to. The implant can also simply be immersed in a bisphosphonate solution or linked with some other biocompatible molecule e.g. carbodiimides, N-hydroxysuccinimide (NHS)-esters, fibrinogen, collagen etc.

In one embodiment the bone contact surface 21 is coated with a double coating. Such double coating may for instance comprise an inner coating comprising titanium (Ti). The second, outer coating, that is configured to contact the cartilage and or bone, is preferably a hydroxyapatite and/or beta tricalcium phosphate (TCP) coating containing more than
5 95% hydroxyl apatite or 95-99.5% hydroxyapatite. By this design even more long-term fixation of the implant is achieved, since bone in- or on-growth to the implant is further stimulated by the titanium, even if the more brittle hydroxyapatite would eventually shed/dissolve.

The bone contact surface may also be further modified with fluoro compounds or acid
10 etching to enhance the bioactivity and the osseointegration of the surface. Another method to facilitate osseointegration is blasting of the bone contact surface.

The extending post

The implant replaces an area of damaged cartilage in an articulating surface of a joint.
15 Before the implant is placed in the desired position, the damaged cartilage is removed and also a part of the bone beneath. Furthermore, a hole can be drilled to fit the implant structure. An extending post or rod-part 23 of the implant 10 (see figure 3), may be used for securing the implant 10 in the drilled hole of the bone. The length 900 of the extending post 23, extending from the bone contact surface 21, is adjusted to a length needed to
20 secure the implant 10 in the bone. The extending post 23 is intended to give a primary fixation of the implant 10; it provides mechanical attachment of the implant 10 to the bone in immediate connection with the surgical operation.

The position of the extending post 23 on the bone contact surface 21 can be anywhere on the bone contact surface 21 or the extending post 23 may have a central position.

25 The extending post 23 has a physical structure in the form of for example a cylinder or other shapes such as one or more of a small screw, peg, keel, barb or the like.

The extending post 23 can in one embodiment of the invention be coated with a bioactive material, for example a bone stimulating material with single or double coatings and/or, a substance inhibiting bone resorption such as described for the bone contact surface 21
30 above. The surface of the extending post can also be further modified using e.g. fluoro compounds or acid etching or blasting, to enhance osseointegration of the surface.

In another embodiment of the invention the extending post 23 is uncoated and the

extending post may comprise e.g. a metal, metal alloy or ceramic material, such as the metal, metal alloys or ceramic materials described for the articulate surface 15 above.

In one embodiment, as exemplified in figure 3a-b, the extending post 23 has a positioning part 25, where the positioning part 25 is located distal to the plate shaped implant body 27. The longitudinal symmetry axes of the first part of the extending post 23 and the positioning part 25 coincide. The diameter of the positioning part 25 is smaller than the diameter of the first part of the extending post 23.

Grafted plug or artificial plug

In an alternative embodiment the surgical kit of the present invention may be used for mosaicplasty or osteochondral autograft transfer (OATS). In such case the implant to be used with the surgical kit does not have a plate shaped implant body with extending post, but rather is a grafted plug taken from healthy bone and cartilage, see figure 4a-b, or an artificial plug, having the same general shape as a grafted plug but being made of an artificial material (see below). Figure 4a shows a grafted plug 600 in the form of a bone and cartilage plug, such as an osteochondral plug, that has been harvested from a nonbearing part of a joint. The implant body 627 of the grafted plug 600 has a cylindrical to a substantially cylindrical form. By cylindrical to a substantially cylindrical forms meant a form or shape having parallel side walls, and having a cross-sectional profile 81 that is preferably circular or roughly circular but that may also have any other shape, including oval, triangular, square or irregular shape, preferably a shape without sharp edges, see exemplifying cross-sections 81a-d in figure 4c. At the upper part of the grafted plug 600 there is healthy cartilage 606 from the site of harvest, while the lower portion of the grafted plug 600 comprises bone tissue.

The grafted plug 600 may be further reshaped after harvesting by using a sharpener tool, see figure 4b. The sharpener tool may be constructed as a pencil sharpener, with a sharp blade, but which may be used to adjust the shape and/ or the length of the bone part of the grafted plug 600, in order to arrange such that several plugs may fit together in an area of cartilage damage. The implant body 627, i.e. the upper part of the sharpened grafted plug 600, still has a cylindrical form, as defined above, i.e. with parallel side walls and a cross-sectional profile 81 that can have various shapes.

In another embodiment the plug used for mosaicplasty or OATS may be an artificial plug made of an artificial material such as synthetic polymer scaffolds, e.g. polylactide-co-glycolid, calcium sulfate, polycarbonate polyurethane or polyglycolide fibers or synthetic calcium. Such artificial plugs have the same geometrical shapes as the grafted plug 600

described above. Importantly for the present invention the artificial plug, like grafted plug 600, has an implant body 627 with a cylindrical form, that is a form or shape with parallel side walls and with a cross-sectional profile 81 that is preferably circular or roughly circular, but that may also have any other shape, including oval, triangular, square or irregular shape, preferably a shape without sharp edges.

A grafted plug 600 or an artificial plug, used with the present invention has a cross-sectional area that is between 0.5 cm² and 5 cm², between 0.5 cm² and 3 cm², or preferably between about 0.5 cm² and 2 cm² at its cylindrical portion. It has a length 710 that is between 1 and 4cm, or between 1.5 and 3 cm. The cross-sectional diameter at the cylindrical portion may for example be 0.1-1 cm.

Figures 4d-e show a cartilage damage site repaired using mosaic repair technique, figure 4d from a cross-sectional side view of the joint, and figure 4e from above. Several grafted plugs 600 have been inserted at the site of damaged or diseased cartilage, to form a mosaic pattern. Figure 4e also shows that grafted plugs 600 have been harvested from the healthy part of the joint (right hand side of the figure).

According to an embodiment of the present invention the amounts of plugs and also the size and shape of the healthy cartilage and bone plugs are selected depending on the shape and size of the injury.

The set of tools

The set of tools comprises a guide base 12, to which a guide body 13 with a guide channel 54 is releasable attached, see figures 5-7. It may also comprise a selection of insert tools, for use when mounting an implant 10, a grafted plug 600 or an artificial plug to the implant site, see figures 2 and 8-11. The insert tools are in operation inserted in the guide channel 54 of the guide body 13 and fits in the guide channel 54, with a slight tolerance to allow a sliding movement of the insert tool in the guide channel 54. The cross-sectional profile, and thus the circumferential shape of the insert tools, corresponds to the chosen cross-section 81 of the implant body 27, 627 of the implant 10, grafted plug 600 or artificial plug, in size and shape (see figure 13a-b). The insert tools are in different embodiments of the invention provided in the form of for example a cartilage cutting tool, a punch, a drill, a drill guide, a bone cutting tool, a reamer guide and/or a hammer tool. Some insert tools are used together with further tools such as a drill bit and/or a reamer bit. An exemplifying set of insert tools will be described herein. The modular surgical kit of the invention may further be used with other insert tools, such as insert tools disclosed in

PCT application PCT/EP2011/058473 or European patent application 11163405.1.

Guide base, guide body and guide insert

Figure 6 shows an exemplifying embodiment of a modular surgical kit of the invention, for use in a knee joint. Figure 7 shows an exemplifying embodiment of a modular surgical kit of the invention, for use in a toe joint. The modular surgical kit comprises a guide base 12 that is releasably attached to a guide body 13. Figures 5a-d show the guide base 12 in more detail.

Two embodiments of a guide base 12 for use in a knee joint are shown in figures 5a-b, and one embodiment of a guide base 12 for use in a toe joint is shown in figures 5c-d. In figures 5b and 5d the guide base 12 is placed on the femoral bone 141 of the knee joint and a falangeal joint bone 142 of a toe respectively. The guide base 12 comprises a positioning body 11 and a guide hole 53, which may alternatively be denoted guide recess or guide opening or similar, through said positioning body 11. The positioning body 11 has a cartilage contact surface 50 that has a shape and contour that is designed to correspond to and to fit the contour of the cartilage or the subchondral bone in the joint in a predetermined area surrounding the site of diseased cartilage. The cartilage contact surface 50 may be adapted to fit to the joint of an average patient or may be adapted, i.e. custom made, for an individual patient. The positioning body 11 also has a top surface 52 facing the opposite direction compared to the cartilage contacting surface 50.

The guide hole 53 has a muzzle 29 on the cartilage contact surface 50, at a position of the positioning body 11 that corresponds to the site of the diseased cartilage, i.e. the site of implantation. In one embodiment the guide hole 53 has a cross-sectional profile that is designed to correspond to the cross-section 81 of the implant body 27, 627 of the implant 10, grafted plug 600 or artificial plug to be implanted. In another embodiment the guide hole 53 has a cross-section that is slightly larger than the cross-section 81 of the implant body 27, 627. In a further embodiment the cross-sectional profile of the guide hole 53 need not correspond to the cross-section 81 of the implant body 27, 627. Where the cross-sectional profile of the guide hole 53 is different from the cross-section 81 of the implant body 27, 627, correspondence or matching to the cross-section 81 of the implant body 27, 627 is provided by the cross-sectional profile of the guide channel 54 of the guide body 13 only (see below).

An embodiment of a guide body 13 is shown in figures 6 and 7. The guide body 13 has a guide channel 54 that extends through the guide body 13. The outer shape and design of the guide body 13 may vary, as is schematically illustrated by a circular design 13a and a

square design 13b in the top row of figure 13a (implant 10 and guide body 13a, 13b seen from above). The guide channel 54 of the guide body 13, however, has an inner cross-sectional profile (see figure 13a-b) that is designed to correspond to the cross-section 81 of the implant body 27, 627. In other words, the implant body 27, 627 fits the guide channel 54, with a slight tolerance to allow a sliding movement of the implant in the guide channel 54.

In an alternative embodiment the guide body 13 has a guide channel that has a cross-sectional profile which is larger than the cross-sectional profile 81 of the implant body 27, 627. In this case the guide channel 54 that is designed to correspond to the cross-section 81 of the implant body 27, 627 is instead provided by a guide insert 8 (see figures 6 and 7, and top view in figure 13a-b). The guide insert 8 is designed to have outer proportions to make it fit into the guide channel of the guide body 13. Its guide channel 54 is designed to have an inner cross-sectional profile that corresponds to the cross-section 81 of the implant body 27, 627. In other words, the implant body 27, 627 fits the guide channel 54, with a slight tolerance to allow a sliding movement of the implant in the guide channel 54. In this way the guide insert 8 works as an adapter, such that a guide body 13 with a guide channel of a certain size might be used for implantation of implants of various sizes, by use of guide inserts 8 with varying guide channels 54 that fit implants of corresponding varying sizes.

The height 31 of the guide channel 54 must be sufficiently long to give support to the tools used inside the guide body 13. The height 31 of the guide channel 54 is preferably also sufficiently high to be easily accessible for the surgeon during surgery. In one embodiment, the top of the guide channel 54 is designed to project above the tissue surrounding the surgery cut when the guide tool is placed on the cartilage in a joint during surgery. The height 31 is preferably higher than the thickness of the surrounding tissue. In this way, the opening of the guide channel 54 is easy to access for the surgeon. The height 31 of the guide channel 54 is between 1 and 10 cm, preferably 3-10 cm and always sufficiently high to ensure stabilization of the tools that are to be inserted into the guide channel 54.

Figure 8 shows an embodiment of a guide body 13, for use in mosaicplasty or OATS surgery. The guide body 13 comprises at least two guide channels 54. Each of the guide channels 54 is designed to have a cross-sectional profile that corresponds the cross-section 81 of an implant body 627 of a grafted plug 600 or an artificial plug. The at least two guide channels 54 may have cross-sectional profiles that are identical. Alternatively their cross-sectional profiles may be different in shape and/or size/area, depending on the cross-sectional profile 81 of the respective grafted plugs 600 or artificial plugs, that are to be

implanted. Each of the guide channels 54 may also be arranged in the guide body 13 at different angles, depending on the angle in which the respective plugs are to be implanted.

The guide body 13 may be provided with an inspection window 39, i.e. a window or hole through the side of the guide body 13, into the guide channel 54, see figures 6 and 7. The inspection window 39 facilitates inspection of the site of implantation during surgery, also when the guide body 13 is attached to the guide base 12, see figures 14c-h.

The guide base 12 comprises means for releasable attachment 47 to the guide body 13, see figures 5a and b-c and figure 6. Such means 47 are arranged such that when the guide body 13 is attached to the guide base 12 the guide body 13 extends from the top surface 52 of the guide base 12. Such means for releasable attachment 47 are also arranged such that, when attached, the guide channel 54 is positioned in relation to the positioning body 11 such that its muzzle 32 emanates at a site corresponding to the site of implantation into the bone, which is also at the site of the guide hole 53. The angle of the guide hole 53 in the positioning body 11 and the arrangement of the releasable attachment means 47 also determine the angle of the guide channel(s) 54 in relation to the positioning body 11 and implantation site. The guide hole 53 and/or the means for releasable attachment 47 are arranged such that, when the guide body 13 is attached to the guide base 12, the angle of the guide channel(s) 54 will correspond to the angle in which the implant 10, grafted plug(s) 600 or artificial plug(s) is/are to be inserted. For small implants 10 the angle of implantation, and thus of the guide channel 54, is most often perpendicular to a tangential plane of the site of implantation. For implants 600 used in mosaicplasty or OATS surgery the angle of implantation of the respective plugs, and thus of the respective guide channels 54, may vary.

In one embodiment the cross-sectional profile of the guide hole 53 and the guide channel 54 correspond and the guide hole 53 and the guide channel 54 are aligned. That is, the symmetry axis of the guide hole 53 and the longitudinal symmetry axis of the guide channel 54 approximately coincide. The cross-sectional profile of the guide hole 53 and of the guide channel 54 may in another embodiment be different. The cross-section of the guide hole 53 must however be at least as big as the cross-section of the guide channel 54, the cross-section of the guide channel 54 must correspond to the cross-section 81 of the implant body 27, 627 and the muzzle 32 of the guide channel 54 must emanate at a site corresponding to the site of implantation, when the guide body 13 is attached to the guide base 12.

The means for releasable attachment 47 may be provided by a snap fit function between the guide base 12 and the guide body 13, and/or by the guide hole 53, or part of the guide

hole 53, and the lower part of the guide body 13 being provided with matching threads and/or bayonet mount and/or other form fitting mechanisms. Other releasable attachment mechanisms are however also conceivable.

The guide base 12 is easy to place due to the precise fit of the positioning body 11 on the cartilage surface. The guide base 12 is designed to be inserted in a lesion which is as small as possible to be able to repair the specific cartilage damage. The size and shape of cartilage contact surface 50 of the guide base 12 is determined depending on the size and shape of the damaged cartilage and also depending on the position of the cartilage damage in the joint. The size and shape of the surface 50 and the positioning body 12 is a consideration between the following aspects; minimize surgery lesion, maximize stability for the guide base 12, anatomic limitations on the site of the injury, and that not all cartilage surfaces in a joint can be used for placement of the guide tool. A large spread of the cartilage contact surface 50 is to prefer to get good stability of the guide tool, however, a large surface area of the surface 50 may also lead to a large surgical intervention and this is undesired. Thus the size of the cartilage contact surface 50 and of the positioning body 11 is determined by a balance between the desire to achieve good positioning stability and small surgical operations. Also, the cartilage contact surface 50 does not need to have a continuous, regular shape, but may have an irregular shape, as long as it gives adequate support and stable positioning of the guide base 12.

When designing the guide tool, the cartilage contact surface 50 can be designed to cover three points (see figure 5b, points 40, 42, 44 for an example) distributed over the cartilage surface of the joint where the implant is to be inserted. The points are chosen to give maximum support and positional stability for the positioning body 11 and thus these points, either decided and identified by the surgeon or automatically identified by design software, serve as the ground when designing the surface 50 of the guide base 12. The cartilage contact surface 50 can also be formed such that it uses the curvature in the cartilage surface in a joint for stability. For example, in a knee joint, the condyles are separated from each other by a shallow depression, the posterior intercondyloid fossa, this curvature together with the medial epicondyle surface can be used to give the cartilage contact surface 50 a stabile attachment to the cartilage surface in a knee joint. The surface is in one embodiment a continuous surface covering a selected area surrounding the cartilage damage. In another embodiment the cartilage contact surface is distributed over a plurality of points, preferably three or more of separated contact points. The cartilage contact surface does not need to be a continuous, regular surface, but preferably has at least three points exemplified by 40, 42 and 44 for stability.

Optionally the cartilage contacting surface 50 can be further stabilized by attachment with nails, rivets or similar attachment means 48 to the bone surrounding the cartilage in a joint (see figure 5b). This additional attachment with rivets or the like gives additional support and stability and also gives the possibility to keep the cartilage contact surface as small as possible. The position of the rivets may be predetermined and marked out on the surface 50 by premade drill holes.

In an alternative embodiment the positioning body 11 may be arranged with attachment means 9 for attachment of adaptors 17, pins and possibly other devices to the guide base 12, see figures 5a, c and d, 6, 7 and 14a-b. Such attachment means 9 may for example connect to the adaptor 17, pin or other device through a snap fit function, thread function or any other form fitting function. The adaptors 17 shown in figures 6, 7 and 14b have holes or bores that can receive pins, nails, rivets or similar means 48 in order to secure the attachment of the guide base 12 to the bone as described above. The elongated form of the adaptors 17 allow such pins or similar means to be inserted into the bone at a distance from the site of implantation. Adaptors of the embodiment shown in figure 14b also have a shape, i.e. both bent and somewhat elongated, such that the pin holes will be both lifted or elevated from the joint surface and situated at a distance from the site of implantation. This shape is advantageous since it will be easier to keep the surface of the joint free of waste and debris from the implantation wound and surroundings and since it will be possible to insert the pins more straight from above. Inserting the pins from at an angle from the side often means that the skin around the site of incision has to be more split open and thus that the wound will be bigger. This is thus avoided when using adaptors as seen in figure 14b.

As stated above, the size and shape of the positioning body 11 of the guide base 12 is determined in order to minimize the surgical intervention while also maximizing the stability of the guide base 12 in the joint. While designing the guide base 12, e.g. by use of X-ray, MR or CT images from the patient it is normally desired to have a positioning body that is as large as possible, in order to ensure maximum stability and proper positioning of the guide base 12 in the joint. However, not all facts on the patient's joint may be known through the X-ray, MR or CT images, and thus the surgeon may want to adjust the positioning body 11 during surgery. For example, osteophytes might have formed in the joint and are often difficult to identify in the imaging procedures. Also, the surgeon might find during surgery that the shape of the guide base 12 requires an unnecessarily large incision to be able to insert the guide base 12 into the joint. In order to facilitate adaptation of the size and shape of the guide base 12 during surgery, the positioning body may be arranged with breakage means 57 that enable easy removal of part(s) of the

positioning body 11 by tearing, fracturing or similar ways of breakage, see e.g. figure 5a. Such breakage means 57 may for example be provided through grooves, slots or perforations or other weakening of the structure.

The guide base 12 with guide body 13 aid with exact precision removal of a volume of cartilage and subchondral bone and also guide the placement of the implant 10, the grafted plug 600 or the artificial plug in for example a knee. Placement of the guide base 12 on the cartilage surface of a knee or a toe can be seen in figures 5b and 5d. The use of the guide base 12 and guide body 13 is further explained below in connection to figures 14a-t.

10 The guide base 12 and the guide body 13 are manufactured using suitable materials that are approved for use in medical procedures, e. g. a ceramic, plastic, metal, metal alloy or alumina material, or a combination. The guide base 12, especially the cartilage contact surface 50, is also preferably made of a material that is smooth, even and/or has low friction, in order to lessen the risk of wear and damage to the cartilage on which it is to be placed. Such materials include e.g. metals ceramics and polymers such as acrylonitrile butadiene styrene (ABS). The used materials may further be polished. In a preferred embodiment the guide base 12 is made of a plastic material, such as polyamide or epoxy, while the guide body 13 is made of a metal material or stainless steel. The plastic material of the guide base 12 is easy to manufacture, e.g. using selective laser sintering (SLS) or stereolithography (SLA) technologies, also when adapted for a specific patient. It is also gentle to the cartilage surface of the joint. The metallic material of the guide body 13 on the other hand, provides a wear resistant material that is to be in contact with the insert tools, thus minimizing the risk of generating wear debris from the guide body for example during drilling. It is also autoclavable and thus reusable. In one embodiment the guide base 12 is adapted to a specific patient, by having a cartilage contact surface 50 and a positioning body 11 that are designed to match the cartilage surface and the shape of the joint of the patient. In one embodiment the guide body 13 is made in a number of standard shapes and sizes, matching corresponding shapes and sizes of a set of standard implants 10, while in another embodiment the guide body 13, as well as the implant 10, is also adapted to the specific patient.

Drill adjustment device

In a preferred embodiment the surgical kit further comprises a drill adjustment device 16 as for example illustrated in figures 2, 6 and 7. The drill adjustment device 16 of the embodiment shown is arranged for attachment to the top of the guide body 13, e.g. by

threads. The drill adjustment device 16 is further arranged such that it may be used to adjust the length of the guide channel 54. The length 31 of the guide channel 54 determines the depth of drilling and cutting of the bone in the joint, as will be described further below. Thus, by being able to adjust the length 31 of the guide channel the surgeon is also able to adjust the depth of drilling and cutting into the bone. The length 31 of the guide channel may be varied since the guide body 13 and the drill adjustment device 16 are able to move in relation to one another when attached. This may for example be achieved by corresponding threading of the guide body 13 and drill adjustment device. Further, the guide body 13 and/or drill adjustment device may be arranged such that the length 31 of the guide channel may be varied at certain intervals, e.g. at 200 μm intervals, or any other desired interval. This may for instance be achieved by arranging the guide body 13 and/or the drill adjustment device 16 such that they are able to move in relation to one another at certain intervals. For example, the threading may be arranged such that the guide body 13 and drill adjustment device 16 may be turned in relation to one another at preset intervals, and that they are locked in relation to each other or prone to hook each other at those intervals. This is readily implemented by a snap fit function.

The drill adjustment device 16 may be used by the surgeon to adjust the depth of drilling, e.g. by increasing the drill depth in steps at the preset intervals. The drill adjustment device is advantageously used together with an implant dummy 36, as described below, to make sure that the drill depth in the bone matches the height 14 of the implant body 27. This ensures that the articulate surface 15 of the implant 10 will be in line with the surrounding cartilage at the site of implantation once implanted. For further description of how the drill adjustment device 16 is used during surgery, see below in connection with figures 14j-p.

An alternative embodiment of a drill depth adjustment tool that may be used with the invention is disclosed in PCT application PCT/EP2011/058473, see e.g. pages 20-21 of the description and figures 12-14. Another way to adjust the drill depth is also to have an adjustable depth gauge on the drilling tool, see below.

30 Cartilage cutting tool

The cartilage cutting tool 3 is a tool which is used to cut the cartilage in the joint around the area of damaged cartilage to prepare for the insertion of the implant. The cartilage cutting tool may for example be a cartilage cutter 3, as shown in figures 2 and 9, a punch or a cartilage cut drill. It is used inside the guide channel 54 of the guide body 13 and fits in the guide channel 54, with a slight tolerance to allow a sliding movement of the cartilage

cutting tool 3 in the guide channel 54 (see figure 13a-b). The cartilage cutting tool 3 preferably cuts the cartilage so that the cut edges of the cartilage are sharp and smooth. These sharp and smooth edges are of great importance when the implant is placed into the prepared recess in the cartilage and bone. A hole in the cartilage which is cut (or punched
5 or drilled) with the cartilage cutting tool 3 according to the invention ends up with a precise fit of the implant into the prepared cartilage since the cartilage cutting tool allows for an exact, precise cut. The recess in the cartilage, made by the cartilage cutting tool 3 always corresponds to the chosen cross-section 81 of the implant body 27 in size and shape.

10 In one exemplifying embodiment of the invention the cartilage cutting tool is a cartilage cutter 3. The cartilage cutter 3 is used to cut the cartilage in the joint around the area of damaged cartilage to prepare for the insertion of the implant with a cutting technique.

The cartilage cutter 3 has a handle 3a, a cartilage cutter body 3b and a cutting blade with sharp cutting edges 3c. The cartilage cutter body 3b has a cross-sectional profile that is
15 designed to correspond to the inner cross-sectional profile of the guide channel 54 with a tolerance enabling the cartilage cutter body 3b to slide within the guide channel 54 (see figure 13a-b). Also, the cross-sectional profile is designed to correspond to the cross-section of the implant. Thus, the cartilage cutter body 3b fits the inside of the guide channel 54, see figure 13, with a slight tolerance to allow a sliding movement of the
20 cartilage cutter in the guide channel 54. The fit ensures the correct, desired placement of the cartilage cutting edges 3c on the cartilage surface and thus the precise removal of the damaged cartilage area.

The cartilage cutter 3 of the embodiment shown in figure 9 has a cartilage cutter body 3b comprising a circular cutting blade that has been cut at an angle that is not perpendicular
25 to the length of the cutter body 3b. This creates an oval cutting edge 3c with a pointy appearance, further increasing the sharpness of the cartilage cutter 3. The cutting edge 3c is arranged to cut the cartilage in a shape corresponding to the cross-sectional profile 81 of the implant body 27.

The material of the cartilage cutter body 3b is chosen from materials which can give the
30 cartilage cutter 3 sharp cutting edges 3c. The material also needs to be stable in order to withstand the pressure when the cartilage cutter 3 is pushed into the cartilage. Examples of such materials are metals such as stainless steel or ceramic material or a plastic material or a hard coated material, preferably stainless steel.

The cutter body 3b may be permanently attached to the handle 3a, or may, more preferably, be removably attached to the handle 3a, such that the handle 3a is reusable while the cutter body 3b is exchangeable (see figure 9).

5 The cartilage cutter 3 may be provided with a safety stop 4. The safety stop 4 has a cross-sectional profile that is larger than the gross sectional profile of the guide channel 54. In case the cutter would risk digging too deep into the bone the safety stop 4 will be stopped against the top of the guide body 13 and/or drill adjustment device 16, thus preventing the cartilage cutter 3 to be pushed deeper into the bone. This could happen e.g. when the patient suffers from osteoporosis. The distance between the tip of the cutting edge 3c and
10 the safety stop 4, and the relation between that distance and the length 31 of the guide channel 54, will determine the depth that the cartilage cutter 3 is allowed to go into the cartilage and/or bone. The safety stop 4 may be arranged such that that distance is adjustable.

In alternative exemplifying embodiments of the invention the surgical kit may comprise a
15 cartilage cutting tool in form of a punch, to punch out the cartilage, or in form of a cartilage cut drill, to cut the cartilage and also cut/carve/drill the underlying bone, as are disclosed in PCT application PCT/EP2011/058473, see pages 17-18 and figures 2, 5a-b and 10. The punch may for instance be advantageous when the implant 10 has a non-circular shape and/or the extending post 23 is not centrally placed in relation to the implant body
20 27.

Drill and bone remover

In one embodiment of the present invention the surgical kit comprises a drill and bone
remover 2 (see figures 2 and 10) that is used to drill a hole in the bone at the site of
25 cartilage damage, for fastening of the extending post 23 of the implant 10 in the bone tissue, and simultaneously create a recess in the bone tissue at the site where the implant body 27 is to be received. The drill and bone remover 2 comprises a drill and bone remover body 20, a central drill 22 and a bone remover 26, as shown in figure 10. The
30 central drill 22 extends from the center of the drill and bone remover body 20, i.e. corresponding to the position of a centrally placed extending post 23 on an implant 10 having a circular implant body 27. The diameter of the central drill 22 is the same as, or slightly smaller than, the diameter of the extending post 23 of the implant 10 that is to be implanted. The bone remover 26 has a cutting edge that is placed peripherally around the
35 central drill 22. The diameter of the bone remover 26 is the same as, or slightly smaller than, the diameter of the implant body 27 of the implant 10 that is to be implanted, thus

creating a recess that matches the implant body, in which the implant body can be received. The cutting edge of the bone remover 26 is hard enough for cutting or carving bone. It may be made of materials such as stainless steel.

5 The drill and bone remover body 20 is designed to fit the inside of the guide channel 54 of the guide body 13, with a slight tolerance to allow a sliding movement of the drill and bone remover 2 in the guide channel 54. In other words, the cross-sectional profile of the drill and bone remover body 20 matches the cross-sectional profile of the guide channel 54 as well as the of the implant 10, see figure 13a-b. The fit ensures the correct, desired
10 precise direction and placement of the drill hole for the extending post 23, as well as the recess for the implant body 27, in the bone.

The drill and bone remover 2 is also equipped with a depth gauge 7. The depth gauge 7 of the drill and bone remover determines the depth of the created drill hole as well as the recess for the implant body 27. The depth gauge 7 has a cross-sectional profile that is
15 larger than the cross sectional profile of the guide channel 54. The depth gauge 7 will, during the surgical procedure, rest against the top of the guide body 13 and/or drill adjustment device 16, thus preventing the drill and bone remover 2 to drill/carve/cut deeper into the bone. The distance between the tip of the cutting edge of the cutter 2 and the depth gauge 7, and the relation between that distance and the length 31 of the guide
20 channel 54, will determine the depth that the is allowed to go into the cartilage and/or bone. The depth gauge 7 may be arranged such that that distance is adjustable. In a more preferred embodiment the distance is fixed and instead the drill/cut/carve depth is adjusted by adjusting the length 31 through the drill adjustment device 16.

See figure 14g-p for a demonstration of how the drill and bone remover 2 is used and how
25 the drill depth is adjusted using the drill adjustment device 16.

Another exemplified embodiment of the drill and bone remover 2 according to the invention is shown in figure 15. In the exemplified embodiment of the drill and boneremover in figure 15, the bone remover 26 part further comprises flanges 28 which is designed to correspond to, at least a rotational volume of the bone remover part 26
30 corresponds to the shape of an implant comprising a protruding rim on the implant body 27. The rotational volume is a fictive volume achieved by the drill and bone remover when it is rotated around its longitudinal axis.

In alternative exemplifying embodiments of the invention the surgical kit may, instead of an integrated drill and bone remover, comprise a drill bit for drilling the hole for the
35 extending post and a reamer for removing bone where the implant body is to be received

in the bone. Such embodiments may also comprise a drill guide and/or a reamer guide. Examples have been disclosed in PCT application PCT/EP2011/058473, see pages 18-20 and 21 of the description and figures 6-7. Such tools may for instance be used when the implant 10 has a non-circular shape and/or the extending post 23 is not centrally placed in relation to the implant body 27.

Implant dummy and dummy reference

The implant dummy 36 and dummy reference 37, see figures 2 and 11a-b, are used to make sure that the cut, carved or drilled recess in the bone that is to receive the implant body 27, is deep enough to fit the implant. This is very important, since the articulate surface 15 of the implant 10 must not project over the surface of the surrounding cartilage tissue. If it would it could cause a lot of damage to the surrounding cartilage and to the cartilage on the opposite side of the joint. Preferably the articulate surface 15 should form a continuous surface with the surrounding cartilage, neither projecting above nor being sunken below the surface of the surrounding cartilage. The checking of the recess depth is difficult or impossible to do with the implant 10 itself, since the implant 10, e.g. with its extending post 23, is designed to be fixed in the bone once inserted, and thus is difficult or impossible to remove. The implant dummy, on the other hand, is designed for easy removal from the recess once the recess depth has been checked.

The implant dummy 36, see figure 11b, has an implant element 41 that is designed to match the implant body 27. The lower surface 41a of the implant element 41 is a replica of the bone contact surface 21 of the implant that is to be implanted. That is, if the implant 10 and bone contact surface 21 is custom made for the specific patient, the implant element 41 and its lower surface 41a will also be custom made and the lower surface 41a be a replica of the bone contact surface 21. The cross-sectional profile of the implant element 41 corresponds to the cross-sectional surface 82 of the implant body, or is slightly smaller in order to ensure easy removal of the implant dummy from the recess.

The implant dummy 36 also has a top surface 43. The distance 46 between the lower surface 41a of the implant element 41 and the top surface 43 corresponds to the distance that you get when adding the thickness or height 14 of the implant body 27 (corresponding to the depth of the recess in the bone plus the thickness of the corresponding cartilage), the height of the guide hole 53 and/or the length 51a of the dummy reference 37, taking regard to any overlap between the guide hole 53 and the dummy reference 37 when they are attached. For a demonstration on how the recess depth is checked using the implant dummy 36 together with the dummy reference 37, see below in connection with figures

14j-p. In one embodiment the thickness 41b of the implant element 41 is the same as the thickness 14 of the implant body 10, such that the recess depth can also be checked directly using the implant element 41 only, i.e. without the dummy reference 37 and top surface 43.

5 The dummy reference 37, see figure 11a, is arranged to fit to, and possibly releasably attach to, the guide hole 53 of the guide base 12, see figure 14j-k. It is also arranged to receive the implant dummy 36, by being provided with a channel 58. The cross-sectional profile of channel 58 corresponds to the cross-sectional profile of the guide channel 54. Thus the channel 58 is able to receive the implant dummy 36, and also the implant 10,
10 with a slight tolerance that allows a sliding movement of the implant dummy 36 in the channel 58, see figure 13a-b, bottom row to the right. The dummy reference 37 and channel 58 has a length 51a.

To ensure that the implant dummy 36 is placed in a correct orientation in the recess of the bone, i.e. in an orientation that corresponds to the orientation that the implant 10 is to be
15 inserted in, the top surface 43 and/or the implant element 41 may be provided with some kind of marking or shape fit element 43a. A corresponding marking or shape fit element 51b is then provided also on the dummy reference and/or the guide base 12.

Mandrel

20 The mandrel 35 (see figure 2 and 12) consists of a solid body and has a mandrel surface 35a that is designed to fit the articulate surface 15 of the implant 10, i.e. it has a corresponding cross-sectional profile and preferably also a corresponding, although inverted, curvature. The mandrel may also be designed to fit the inside of the guide channel 54, with a slight tolerance to allow a sliding movement of the hammer tool 35 in
25 the guide channel 54. The mandrel 35 is preferably used inside the guide channel 54 to hammer the implant in place, for support and to get the proper angle, or may alternatively be used without the support from the guide channel 54, see figure 14r-s. The height 68 of the mandrel 35 is in one embodiment the same height 31 as of the guide channel 54. For such embodiment, once the mandrel 35 is hammered in the same level as the top of the
30 guide channel, the hammering and thus the placement of the implant is finished.

The hammer tool 35 may also be accompanied by a hammer tool adapter 34, see figure 12, for facilitating the use of the hammer tool and minimizing the absorption of the shock caused by the hammer tool and/or minimize the risk of scratching the surface of the implant 10 while hammering. It is made from a soft material that is gentle to the implant
35 surface, e.g. a rubber or plastic material.

Design method for designing a surgery kit, kits of tools and medical implant, a grafted plug (600) or an artificial plug

The design method describing the design of the surgical kit and set of tools and the implant disclosed herein will now be further explained.

- 5 The method of designing a modular surgical kit for cartilage repair in an articulating surface of a joint according to the invention comprising the steps of:
- I. Determining physical parameters for cartilage damage in a joint, comprising:
- a. obtaining image data representing a three dimensional image of a bone member of the joint;
- 10 b. identifying in the image data a cartilage damage in an articulate surface of the bone member;
- c. determining based on the image data the location of the cartilage damage;
- d. determining based on the image data the size and shape of a cartilage damage;
- e. determining based on the image data the surface contour curvature of the cartilage and/or the subchondral bone in the joint in a predetermined area comprising and
- 15 surrounding the site of cartilage damage;
- II. Generating design parameters for a medical implant (10) , a grafted plug (600) or an artificial plug, comprising:
- 20 a. generating the contour curvature for an articulate surface of an implant body (27, 627) dependent on said determined surface curvature of the cartilage and/or the subchondral bone;
- b. generating a cross-section for the implant body dependent on and substantially corresponding to said determined size and shape of the
- 25 damaged cartilage or corresponding or generating a cross-section for the implant body (27, 627) together with another cross-section for another other implant (10) or grafted plug (600) or an artificial plug to said determined size and shape of the damaged cartilage by forming a pattern;
- c. generating an edge height (14, 710) for the implant body (27, 627) that
- 30 substantially corresponds to the thickness of healthy cartilage plus a selected height of a bone contacting part of the implant for countersinking the implant (10), a grafted plug (600) or an artificial plug into a recess to be made in the bone to fit and receive the implant (10), the grafted plug (600) or the artificial plug;
- 35

III. Generating design parameters of a guide tool for implanting said implant (10) or ,
a grafted plug (600) or an artificial plug comprising:

- 5 a. generating the contour curvature for a cartilage contact surface (50) of a
positioning body (11) dependent on said determined surface contour
curvature of the cartilage and/or the subchondral bone in the joint in a
predetermined area comprising and surrounding the site of cartilage
damage, such that said cartilage contact surface (50) of the positioning
body (11) corresponds to and fits to said surface contour of the cartilage or
the subchondral bone in the joint;
- 10 b. generating the cross-section profile (82, 122) for a guide channel (54) in a
guide body (13) extending from the positioning body (11), said guide
channel (54) passing through said positioning body (11) and said guide
body (13),
the cross-section profile (82, 122) for the guide channel (54) being
15 generated dependent on and substantially corresponding to said
determined size and shape of the damaged cartilage, and such that the
guide channel (54) is designed to have a cross-sectional profile (82, 122)
that corresponds to the cross-section (81, 121) the implant body (27, 627)
or that corresponds to the combination of at least two cross-sections (81,
20 121) of the implant body (27, 627),
and such that the guide channel (54) is designed to have a muzzle (29) on
the cartilage contact surface (50) of the positioning body (11) at a position
corresponding to the site of the diseased cartilage;
- 25 c. generating the shape of the guide body (13) of guide tool, depending on the
design of the positioning body (11) and wherein the guide body (13) is
designed to be releasable attached to the positioning body (11);
- d. generating the cross-section profile (84, 124) for an insert tool to have a
cross-sectional profile that corresponds to the cross-sectional profile (82)
of the guide channel (54) with a tolerance enabling the insert tool to slide
30 within the guide channel (54).

The design method above wherein the order of the said steps k. and l. may be in any
order, for example first k. then l. or first l. then k..

The design method according to the invention further comprising generating design
35 parameters for a drill guide to have a cross-sectional profile that corresponds to the cross-
sectional profile of the guide channel (54) with a tolerance enabling the drill guide to slide
within the guide channel (54),

The design method according to the invention wherein the guide body 13 is a standard component and the positioning body 11 is an individually designed component and wherein the guide body 13 and the positioning body 11 are designed to fit to each other.

5 Detailed description of a method for implanting the implant using the set of tools

Use of the surgical kit and set of tools disclosed herein will now be further explained in connection with an exemplifying embodiment shown in figures 14a-t. The example concerns a surgical kit for implantation of a small implant 10 into a knee joint. The same principles do however apply also for other joints as well as for mosaicplasty surgery. For 10 the latter a guide body 13 with more than one guide channel 54 may be used, and the grafted plug 600 may be a selection of bone and cartilage plugs from a healthy part of the joint, or a selection of artificial implant plugs of various sizes.

1. Localize the area of the injury and determine the desired size and shape of the implant, 15 see figure 1. The position and size of the cartilage damage can be identified by a combination of MRI or CT images or by dGEMRIC technique. The images may then be handled in special surgical planning tool software. All of the parts in the surgical kit may be individual adjusted depending on size of cartilage damage, location of the cartilage damage and also depending on a simulation of the individual surface appearance without 20 damage. Alternatively an implant from a set of predetermined implants may be selected and the set of tools designed or selected thereafter.

2. The implant 10 and set of tools of the invention are manufactured depending on; the size of the implant needed, the localization of the injury, the appearance of the cartilage surface intended to be replaced. The designs may be based on the MR images /CT- 25 scanning images from the joint of the person having the cartilage damage, using the surgical planning software. The surgical planning software is connected to manufacturing devices, for example a laser printer, a lathe and/or a reamer, and the parts of the kit are manufactured using e.g. additive manufacturing, laser sintering techniques, turnery or reaming.

3. A surgical opening is made in the leg tissue depending on the localization of the injury and the size of the implant and also depending on the size and conformation of the guide tool. 30

4. The guide base 12 is placed on the surface of the knee cartilage, see figure 14a. The guide base 12 fits due to the fact that it is custom made to be placed in that particular position.

This allows the surgical procedure (cartilage and bone removal and insertion of the implant) to be performed with good accuracy and precision. If necessary the guide tool can be further stabilized with rivets or pins on a part of the guide tool that is in contact with parts of the joint that have no cartilage tissue. The rivets or pins may also be attached by
5 additional use of adapters 17 that are first attached to the guide base 12 via attachment means 9, see figure 14b.

5. The guide body 13 is attached to the guide base 12 via the releasable attachment means 47, see figures 14c-d. The guide body 13 may further be provided with a drill adjustment device 16 and/or a drill insert 8 that provides a guide channel 54 of the right shape and
10 size, i.e having a cross-sectional profile that corresponds to the cross-sectional profile 81 of the implant that is to be implanted.

6. When the guide body 13 has been attached to the guide base 12, the cartilage cutting tool, here a cartilage cutter 3, is used to cut out a piece of the cartilage that corresponds to the cross-section 81 of the implant 10 that is to be implanted (see figures 14e-f). The
15 cartilage cutter body 3b fits exactly into the guide channel 54 and thus by turning can make a hole in the cartilage of the desired size and with precision to fit the implant size and at the desired position. A depth gauge 4 on the cartilage cutter 3 can be used in order to help make sure that the cutting is not made too deep.

7. After the piece of cartilage has been removed, the drill and bone remover 2 is then
20 inserted in the guide channel 54, see figures 14g-h. When the drill and bone remover 2 is turned/drilled the central drill 22 will give an exact, desired placement of a bore in the bone where the extending post 23 of the implant 10 is to be inserted. The bore is preferably made with a central drill 22 having a slightly smaller diameter than the diameter 18 of the extending post 23 of the implant 10 so that when the implant 10 is
25 hammered in place it will be firmly attached in the bone. When the drill and bone remover 2 is turned/drilled the cutting edge of the bone remover 26 will at the same time create a recess in the bone at the exact desired place and of the desired shape to fit the implant body 27 of the implant 10. Such recess will have a cross-sectional profile that is the same as the cross-sectional profile of the drill and bone remover 2, i.e. the same as the
30 cross-sectional profile of the implant 10.

8. After the drilling and cutting the drill and bone remover 2, as well as the guide body 12 are removed, see figure 13i. The site of implantation can now readily be cleaned from wear and waste from the drilling and cutting, and inspected to see whether the desired result has been achieved.

9. Now, the implant dummy 36 and dummy reference 37 are used to check whether the recess in the bone is deep enough to receive the implant 10, without the implant 10 projecting over the surface of the surrounding cartilage. The dummy reference 37 is first placed and possibly attached to the guide hole 53 of the guide base 12, see figures 14j-k.
- 5 The implant dummy 36 is then inserted to the channel 58 of the dummy reference 37, such that the implant element 41 is in an orientation corresponding to the orientation in which the implant 10 is to be implanted. This can be ensured e.g. by a marking or shape fit element 43a on the implant dummy and a corresponding marking or shape fit element 51b on the dummy reference and/or the guide base 12.
- 10 The implant dummy 36 and dummy reference 37 are arranged such that when the depth of the recess in the bone that is to receive the implant body 27 is deep enough the top surface 43 of the implant dummy 36 and the top edge of the dummy reference should lie flush or in line with each other, see arrow in figures 14l and 14p. This is achieved by arranging the implant dummy 36 and the dummy reference 37 such that the distance 46
- 15 between the lower surface 41a of the implant element 41 and the top surface 43 corresponds to the distance that you get when adding the thickness 14 of the implant body 27 (corresponding to the depth of the recess in the bone plus the thickness of the corresponding cartilage), the height of the guide hole 53 and/or the length 51a of the dummy reference 37, taking regard to any overlap between the guide hole 53 and the
- 20 dummy reference 37 when they are attached (see also above).

As is seen by the arrow in figure 14l the top surface 43 of the implant dummy 36 and the top edge of the implant reference do not lie flush, i.e. not in line, with each other. Thus, some more drilling/cutting into the bone should be made. The implant dummy 36 and dummy reference 37 are removed from the guide base 12 and the guide body 13 with drill

25 adjustment device 16 attached again to the guide hole 53, see figure 14m. The drill adjustment device 16 is then adjusted such that the length 31 of the guide channel 54 is shortened. This may for instance be done by turning the drill adjustment device 16 at a number of preset intervals, e.g. one, two or three times 200 μm , or any other number times any other preset interval, see also above, and figure 14n.

- 30 The drilling and cutting procedure is then repeated; see points 7-8 and figure 14o, and the implant dummy 36 and dummy reference 37 used to check the drill depth again, see figure 14p. In figure 14p the top surface 43 and the top edge of the dummy reference lie flush with each other, see arrow. The recess in the bone then is of suitable depth and is ready to receive the implant 10.

10. The implant 10 may be guided to the exact matching recess at the site of implantation through the guide channel 54 of the guide body 13, or alternatively be placed at the site of implantation without the guide. The later alternative is shown in figure 14q for illustrative purposes.

- 5 11. The mandrel 35 is then used, also either with or without support from the guide channel 54 of the guide body 13, to hammer the implant in position and firmly attach it to the bone. The mandrel 35 is placed on top of the implant 10 and then a hammer or similar tool is used to hammer or push the mandrel 35 (as shown symbolically by the arrow) such that the implant is forced in place, see figure 14s.
- 10 12. Lastly, the hammer tool 35 and the guide base 12 are removed, the implant 10 is implanted at the site of cartilage damage, see figure 14t, and the incision wound can be stitched.

Claims

1. A modular surgical kit adapted for removal of damage cartilage and bone and also adapted for insertion of a medical implant (10), a grafted plug (600) or an artificial plug having an implant body (27, 627) with a predetermined cross-sectional profile (81) and adapted for guiding insert tools during repair of diseased cartilage at an articulating surface of a joint, wherein the modular surgical kit comprising;

an implant, and a medical implant (10), a grafted plug (600) or an artificial plug having an implant body (27, 627) with a predetermined cross-sectional profile (81) a guide base (12) having a positioning body (11) with a guide hole (53) through said positioning body (11), wherein:

the modular surgical kit comprises a drill adjustment device (16) being arranged to enable adjustment of the drill depth e.g. in certain length intervals

the positioning body (11) has a cartilage contact surface (50) that is designed or adapted to fit the contour of cartilage or subchondral bone in the joint in a predetermined area surrounding the site of diseased cartilage

the guide hole (53) has a muzzle (29) on the cartilage contact surface (50) at a position corresponding to the site of the diseased cartilage; and

a guide body (13) with a guide channel (54), the guide channel (54) having a cross-sectional profile that is designed to correspond to the cross-sectional profile (81) of the implant body (27, 627) and having a muzzle 32;

wherein

the positioning body (11) comprises means for releasable connecting (47) to the guide body (13) such that, when connected, the guide channel (54) is positioned in relation to the positioning body (11) such that its muzzle (32) emanates at a site corresponding to the site of implantation into the bone.

2. The modular surgical kit of claim 1, wherein the cartilage contact surface (50) is designed to fit the contour of the cartilage or subchondral bone of an average patient.

3. The modular surgical kit of any of claims 1-2, wherein the guide body (13) comprises at least two guide channels (54), each guide channel (54) having a cross-sectional profile that is designed to correspond to the respective cross-sectional profile (81) of at least two implant bodies (27, 627).

5

4. The modular surgical kit of any of claims 1-3, wherein the guide channel (54) is provided by a guide insert (8) that is designed to fit in the guide body (13).

10

5. The modular surgical kit of any of claims 1-4, wherein the positioning body (11) is arranged with at least one breakage means (57) for enabling easy removal of part of the positioning body (11) by tearing, fracturing or similar breakage, such means (57) for example being provided by grooves, slots or perforations or other weakening of the structure.

15

6. The modular kit of any of claims 1-5, wherein the positioning body (11) is arranged with at least one attachment means (9) for enabling easy attachment of adaptors, pins and other devices used during surgery, e.g. by snap fit.

20

7. The modular kit of claim 6, further comprising adaptors (17) fitting the attachment means (9), for enabling flexible attachment of pins and other devices.

8. The modular surgical kit of claims 1-7, further comprising an insert tool with a cross-sectional profile that is designed to correspond to the cross-sectional profile of the guide channel (54) with a tolerance enabling the insert tool to slide within the guide channel (54).

25

9. The surgical kit of claim 8, wherein the insert tool is a cartilage cutting tool 3 with a cross-sectional profile that is designed to correspond to the cross-sectional profile of the guide channel (54) with a tolerance enabling the cartilage cutting tool 3 to slide within the guide channel (54), and comprising a cutting blade with sharp cutting edges 3c able to cut the cartilage in a shape that substantially corresponds

30

to the cross-section (81) of the implant body (27).

10. The surgical kit of claim 8, wherein the insert tool is a drill and bone remover (2) with a drill and bone remover body 20 having a cross-sectional profile that is designed to correspond to the cross-sectional profile of the guide channel (54) with a tolerance enabling the drill and bone remover (2) to slide within the guide channel (54), the drill and bone remover (2) further comprising a central drill (22), for drilling a bore to receive the extending post (23) of the implant (10), and a bone remover (26) for cutting a recess in the bone to receive the implant body (27) of the implant (10).
11. The surgical kit of claim 8, wherein the insert tool is a mandrel (35) with a mandrel surface (35a) that is designed to fit the articulate surface (15) of the implant (10) and having a cross-sectional profile that is designed to correspond to the cross-sectional profile of the guide channel (54) with a tolerance enabling the mandrel (35) to slide within the guide channel (54).
12. The surgical kit of any of the previous claims, further comprising an implant dummy 36 with an implant element 41 that is designed to match the implant body 27 and having a lower surface 41a that is a replica of the bone contact surface 21, but comprising no extending post 23.
13. The surgical kit of claim 12 further comprising a dummy reference 37 that is arranged to fit to, and possibly releasably attach to, the guide hole 53 of the guide base 12 and is arranged to receive the implant dummy 36, by being provided with a channel 58.
14. The surgical kit of any of the previous claims, further comprising a positioning body (11) has a cartilage contact surface (50) that is designed or adapted to individually fit the contour of the cartilage or subchondral bone in the joint of a specific patient in a predetermined area surrounding the site of diseased cartilage
15. The method of designing a modular surgical kit for cartilage repair in an articulating surface of a joint according to claims 1-14 comprising the steps of:
I. Determining physical parameters for cartilage damage in a joint, comprising:

- f. obtaining image data representing a three dimensional image of a bone member of the joint;
- g. identifying in the image data a cartilage damage in an articulate surface of the bone member;
- 5 h. determining based on the image data the location of the cartilage damage;
- i. determining based on the image data the size and shape of a cartilage damage;
- j. determining based on the image data the surface contour curvature of the cartilage and/or the subchondral bone in the joint in a predetermined area comprising and surrounding the site of cartilage damage;

10 II. Generating design parameters for a medical implant (10) , a grafted plug (600) or an artificial plug, comprising the steps a-c in no specific order:

- d. generating the contour curvature for an articulate surface of an implant body (27, 627) dependent on said determined surface curvature of the cartilage and/or the subchondral bone;
- 15 e. generating a cross-section for the implant body dependent on and substantially corresponding to said determined size and shape of the damaged cartilage or corresponding or generating a cross-section for the implant body (27, 627) together with another cross-section for another other implant (10) or grafted plug (600) or an artificial plug to said determined size and shape of the damaged cartilage by forming a pattern;
- 20 f. generating an edge height (14, 710) for the implant body (27, 627) that substantially corresponds to the thickness of healthy cartilage plus a selected height of a bone contacting part of the implant for countersinking the implant (10) , a grafted plug (600) or an artificial plug into a recess to be made in the bone to fit and receive the implant (10) , the grafted plug (600) or the artificial plug;

30 III. Generating design parameters of a guide tool for implanting said implant (10) or , a grafted plug (600) or an artificial plug comprising:

- e. generating the contour curvature for a cartilage contact surface (50) of a positioning body (11) dependent on said determined surface contour curvature of the cartilage and/or the subchondral bone in the joint in a predetermined area comprising and surrounding the site of cartilage damage, such that said cartilage contact surface (50) of the positioning

body (11) corresponds to and fits to said surface contour of the cartilage or the subchondral bone in the joint;

f. generating the cross-section profile (82, 122) for a guide channel (54) in a guide body (13) extending from the positioning body (11), said guide channel (54) passing through said positioning body (11) and said guide body (13),

the cross-section profile (82, 122) for the guide channel (54) being generated dependent on and substantially corresponding to said

determined size and shape of the damaged cartilage, and such that the

guide channel (54) is designed to have a cross-sectional profile (82, 122)

that corresponds to the cross-section (81, 121) the implant body (27, 627)

or that corresponds to the combination of at least two cross-sections (81, 121) the implant body (27, 627),

and such that the guide channel (54) is designed to have a muzzle (29) on the cartilage contact surface (50) of the positioning body (11) at a position corresponding to the site of the diseased cartilage;

g. generating the shape of the guide body (13) of guide tool, depending on the design of the positioning body (11) and wherein the guide body (13) is designed to be releasable attached to the positioning body (11);

h. generating the cross-section profile (84, 124) for an insert tool to have a cross-sectional profile that corresponds to the cross-sectional profile (82) of the guide channel (54) with a tolerance enabling the insert tool to slide within the guide channel (54); and

wherein said steps III c. and III d. of said design method comprising steps I a-e, II a-c, III a-d. may be in any order, for example first III c. then III d. or first III d. then IIIc.

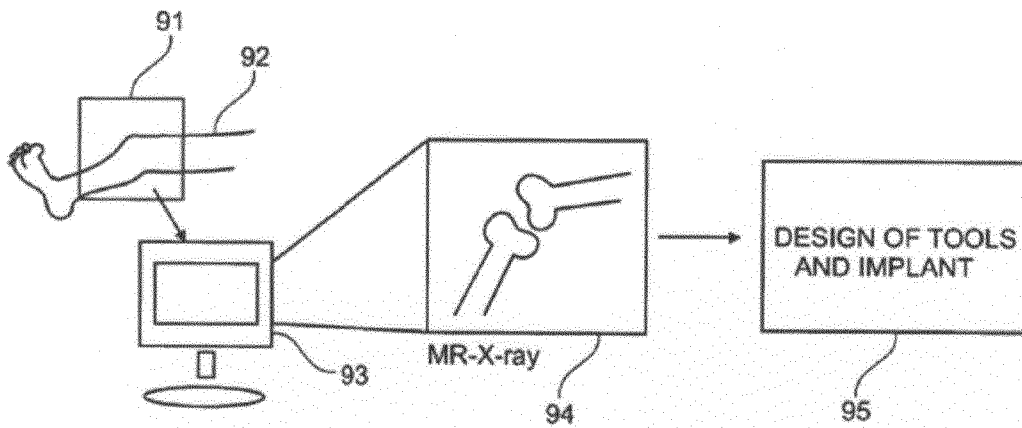

Fig. 1

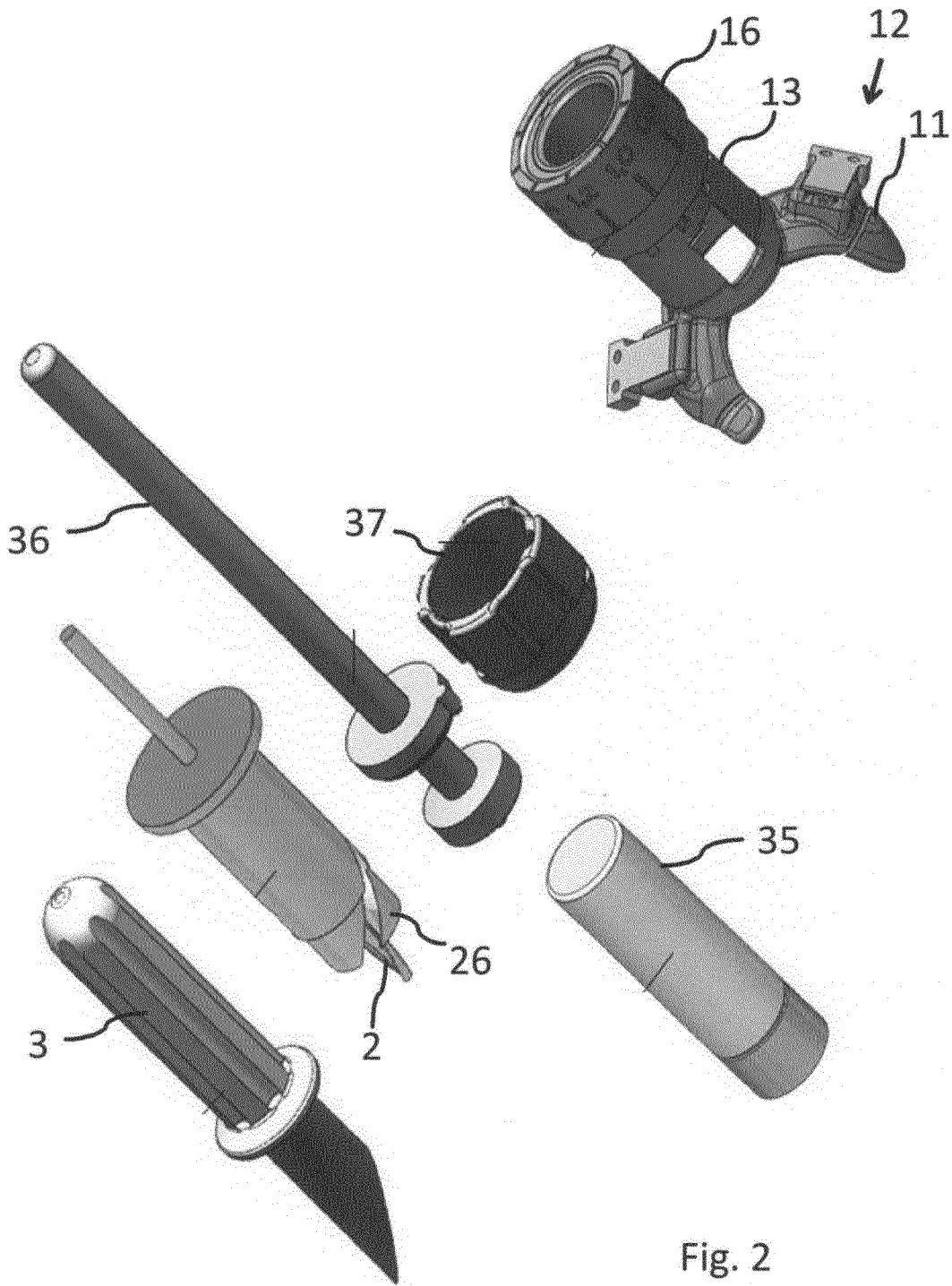

Fig. 2

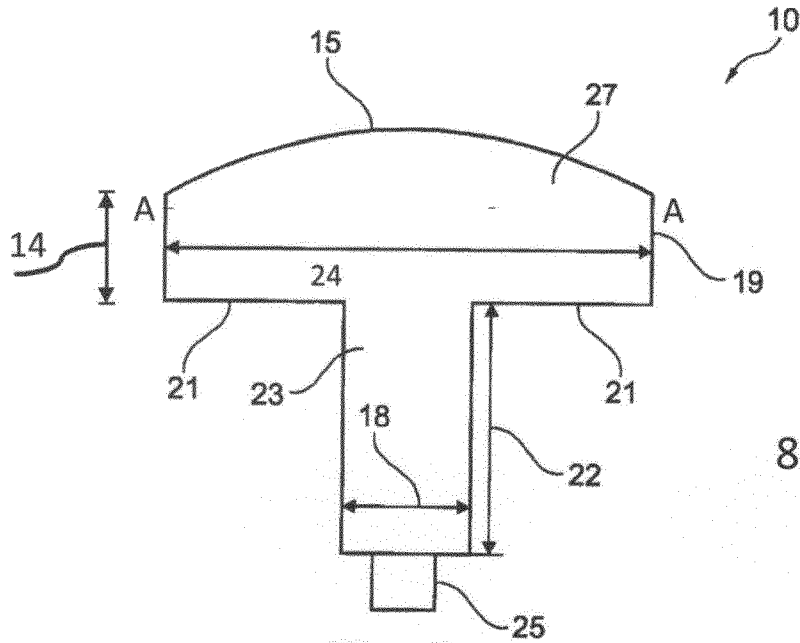

Fig. 3a

Section A-A

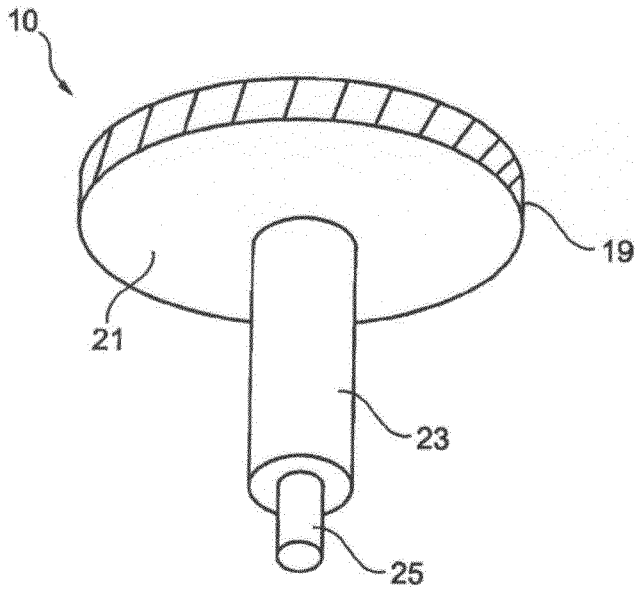
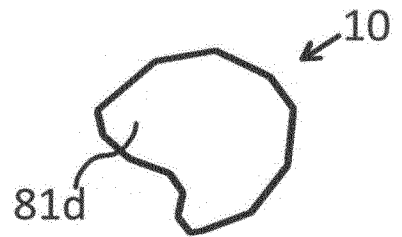
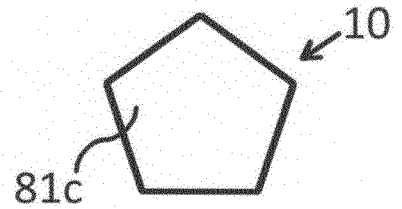
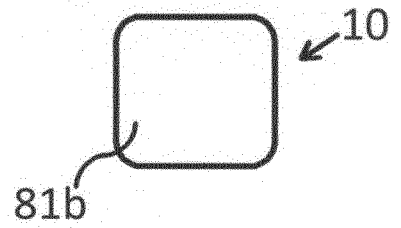
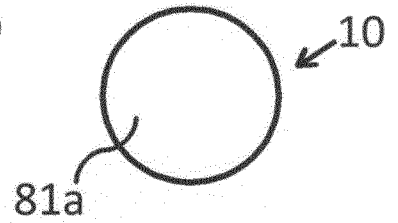
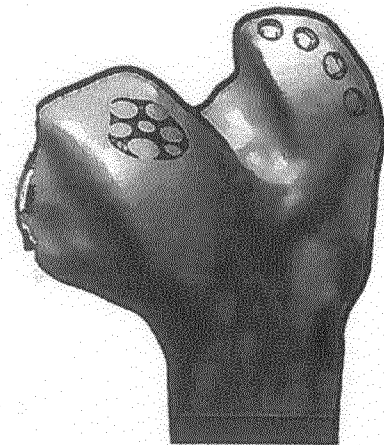
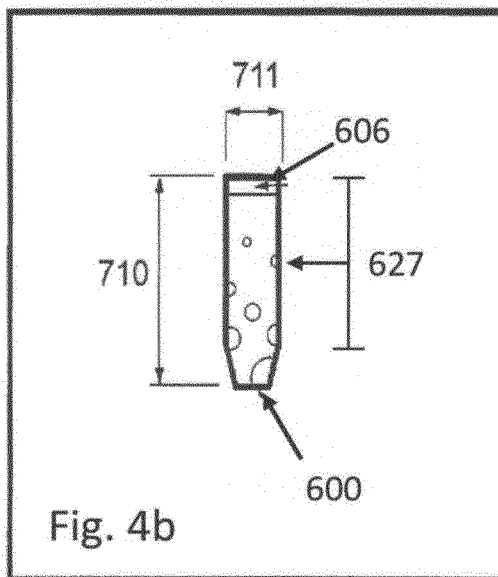
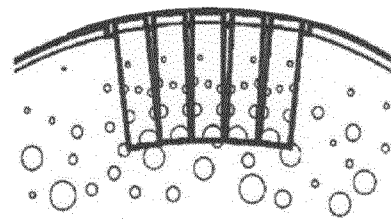
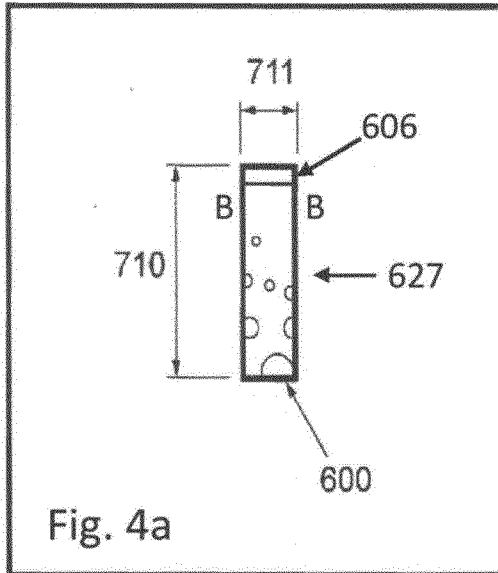

Fig. 3b

Fig. 3c



Section B-B

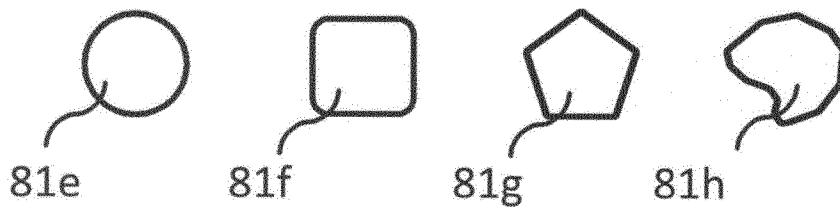

Fig. 4c

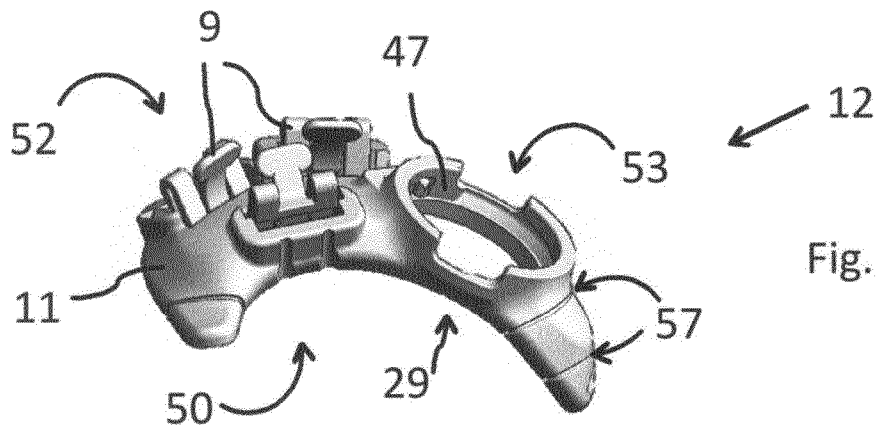

Fig. 5a

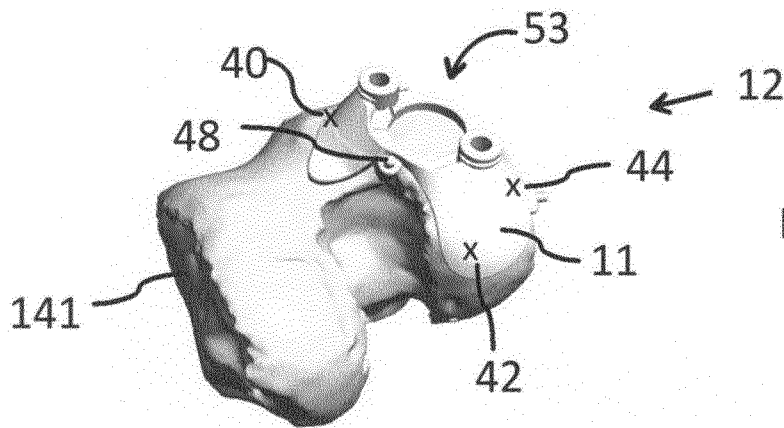

Fig. 5b

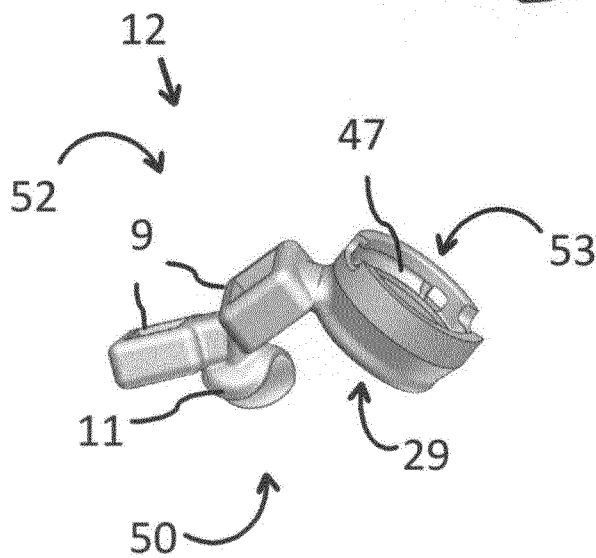

Fig. 5c

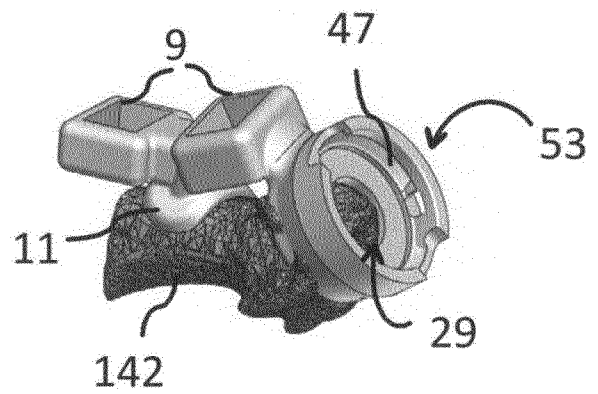

Fig. 5d

6/16

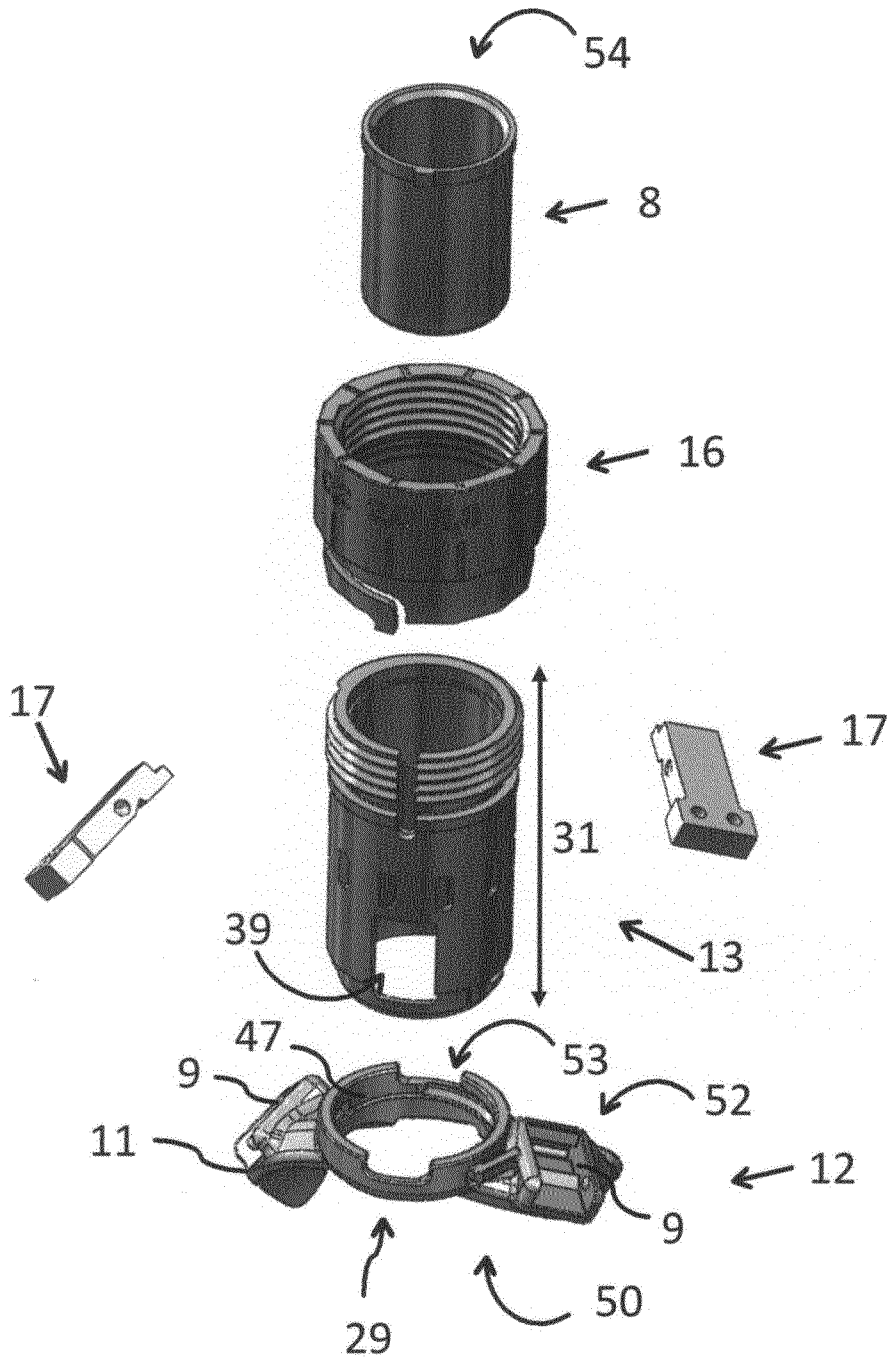

Fig. 6

7/16

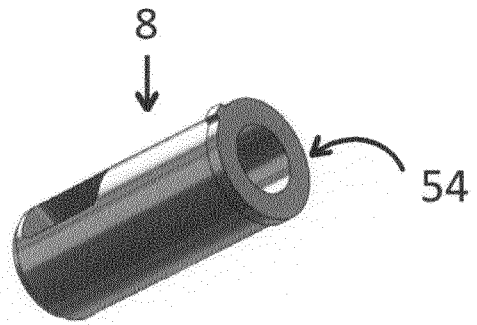
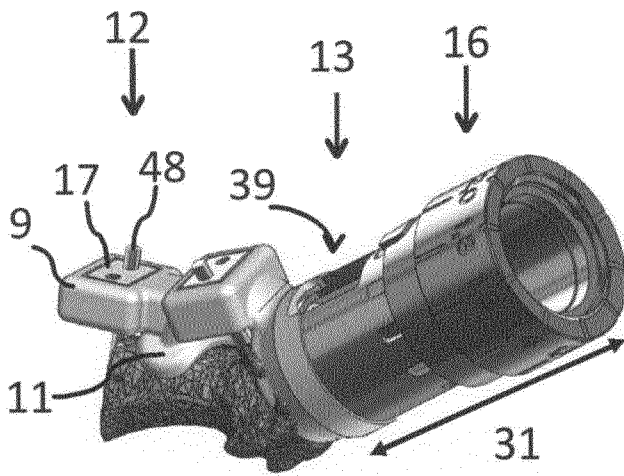

Fig. 7

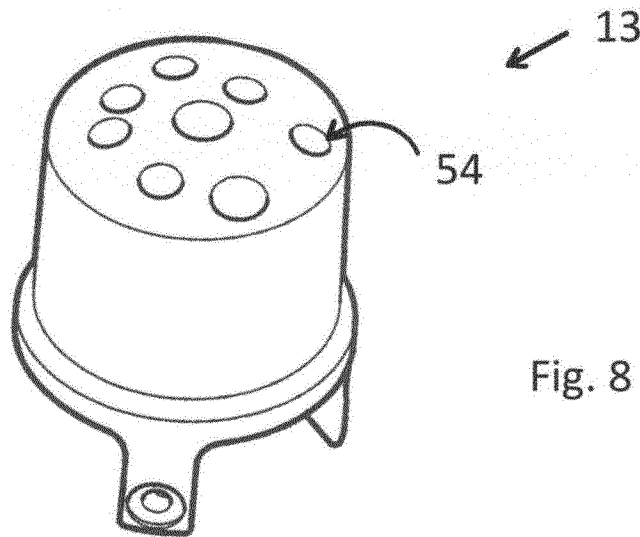

Fig. 8

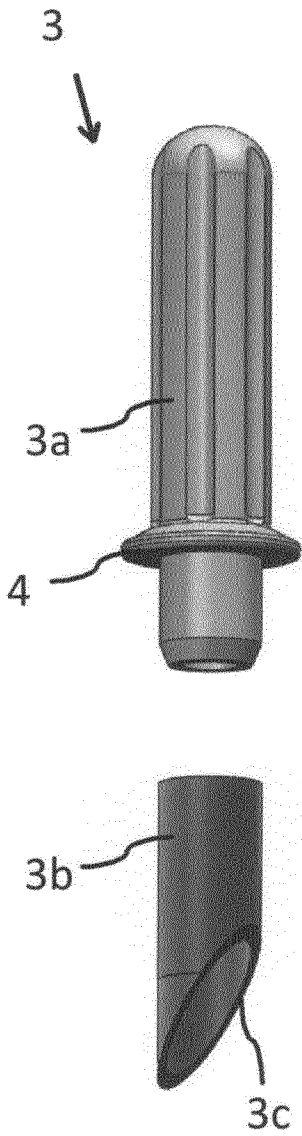

Fig. 9

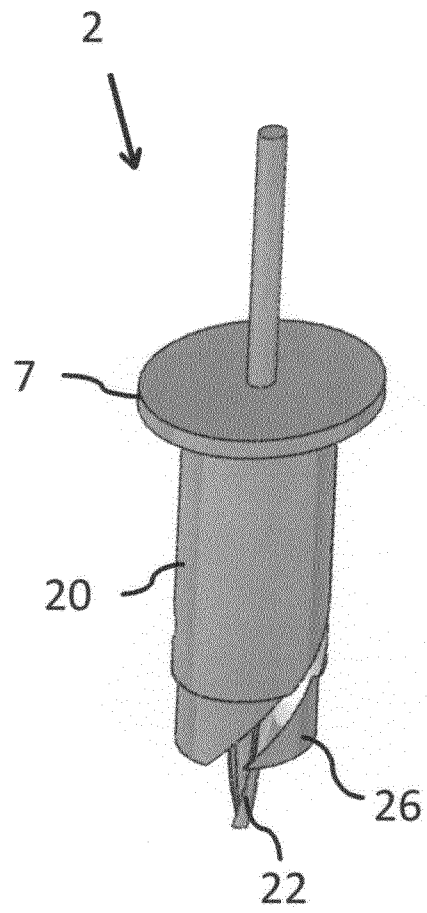

Fig. 10

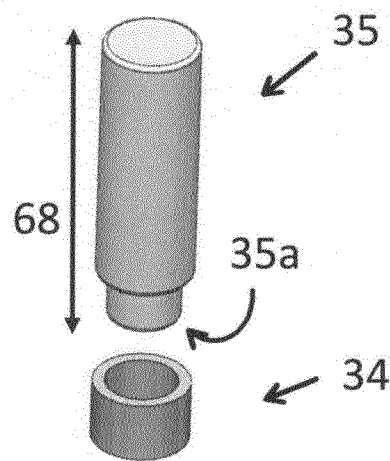
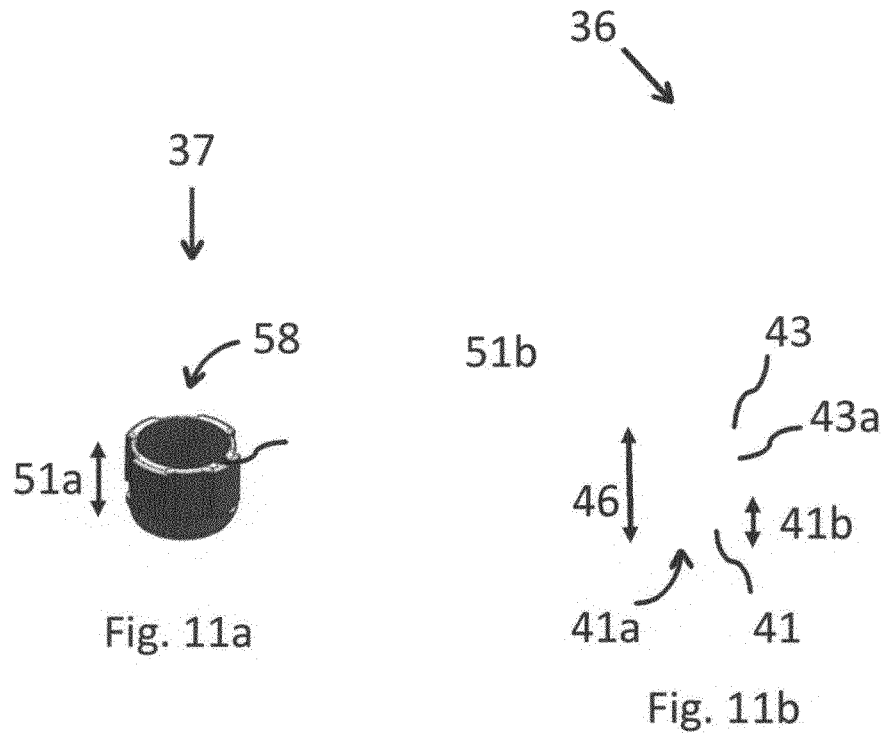

Fig. 12

10/16

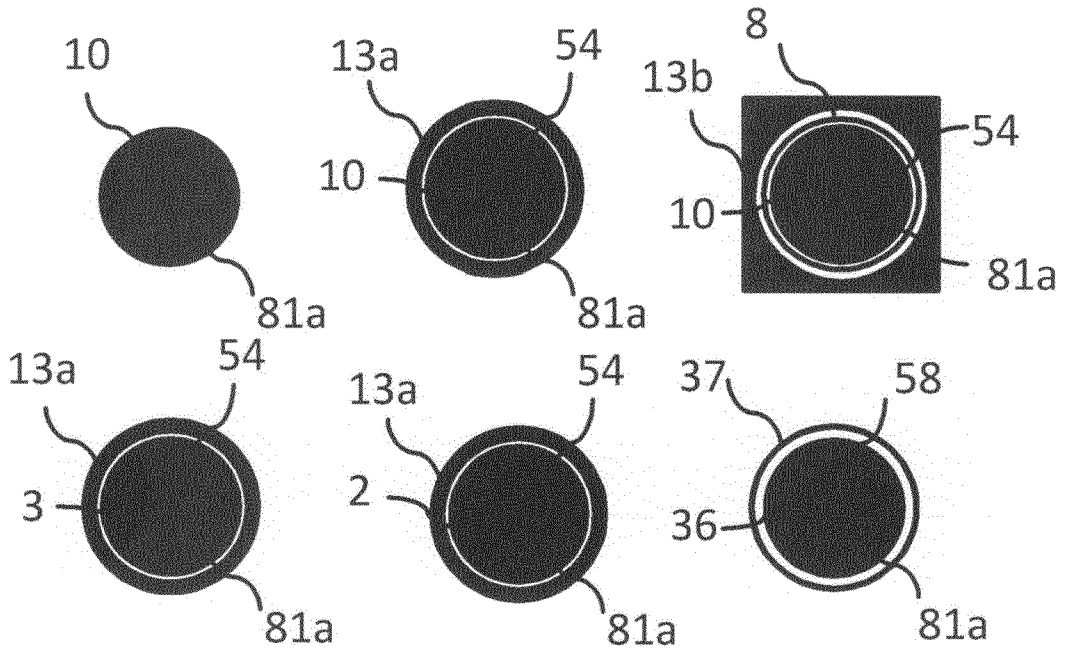

Fig. 13a

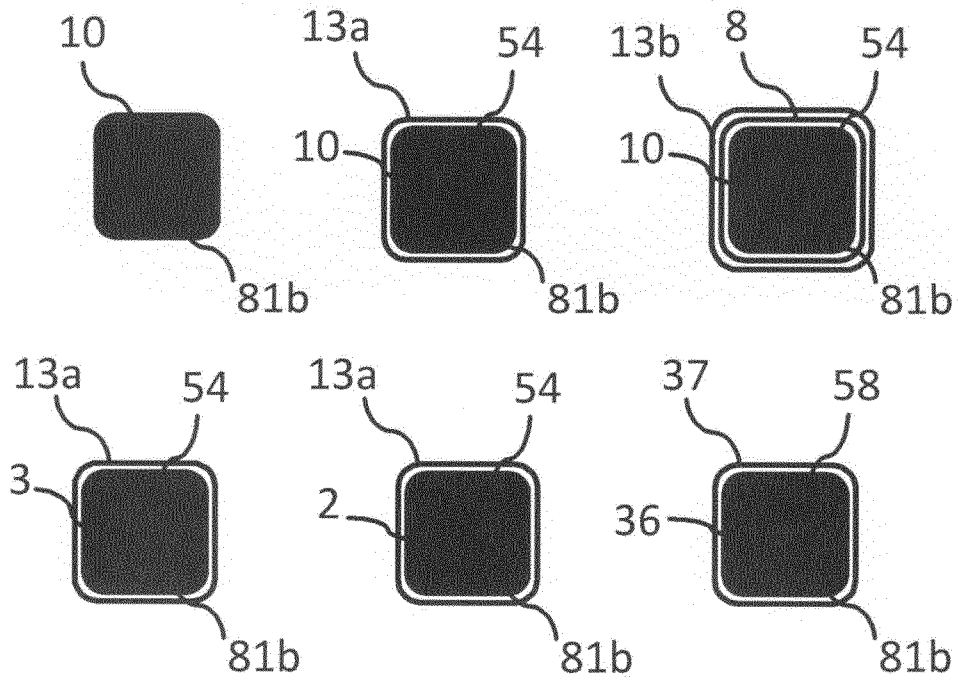

Fig. 13b

11/16

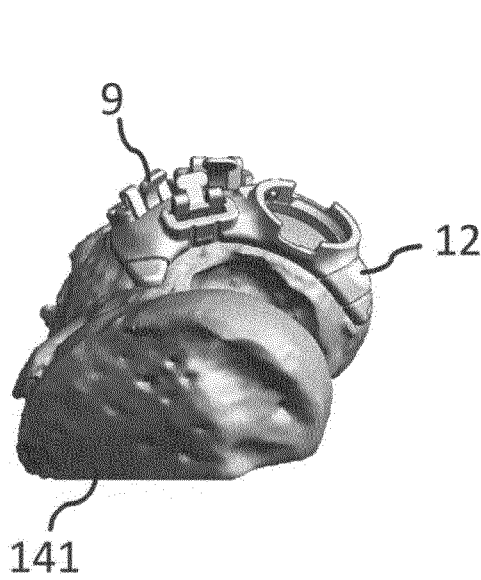

Fig. 14a

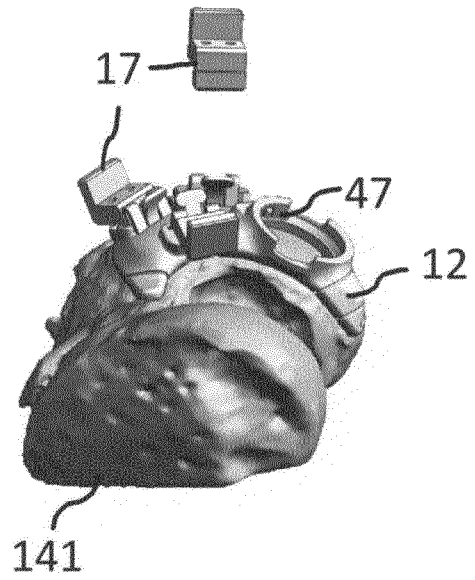

Fig. 14b

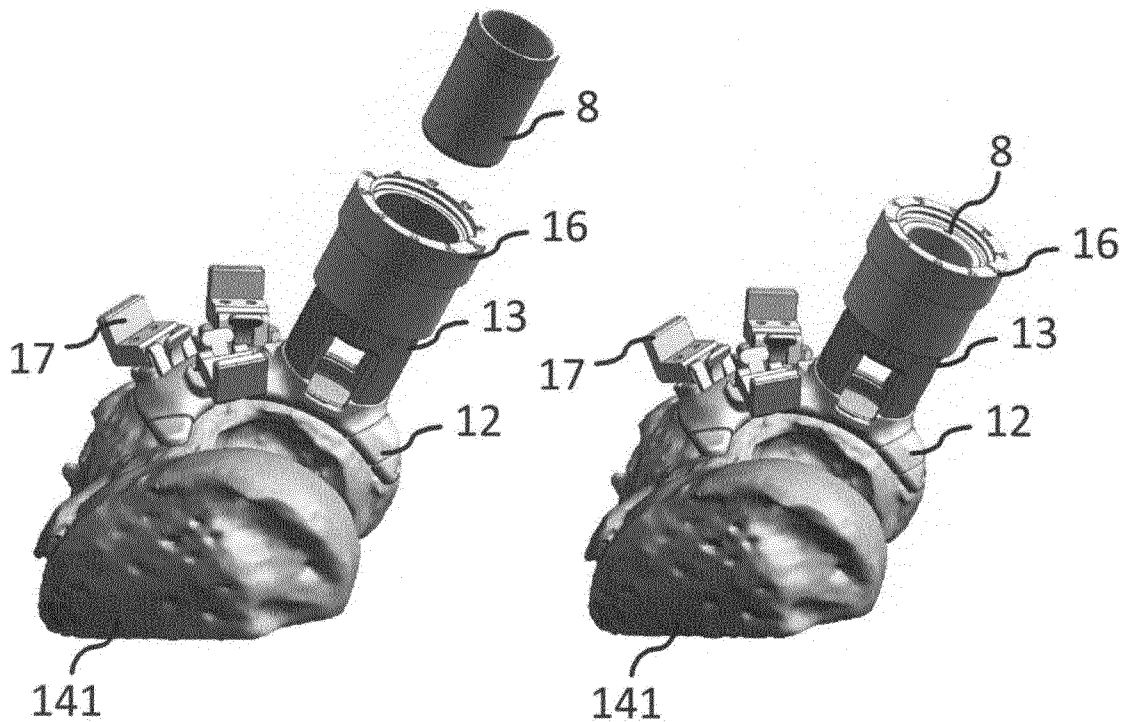
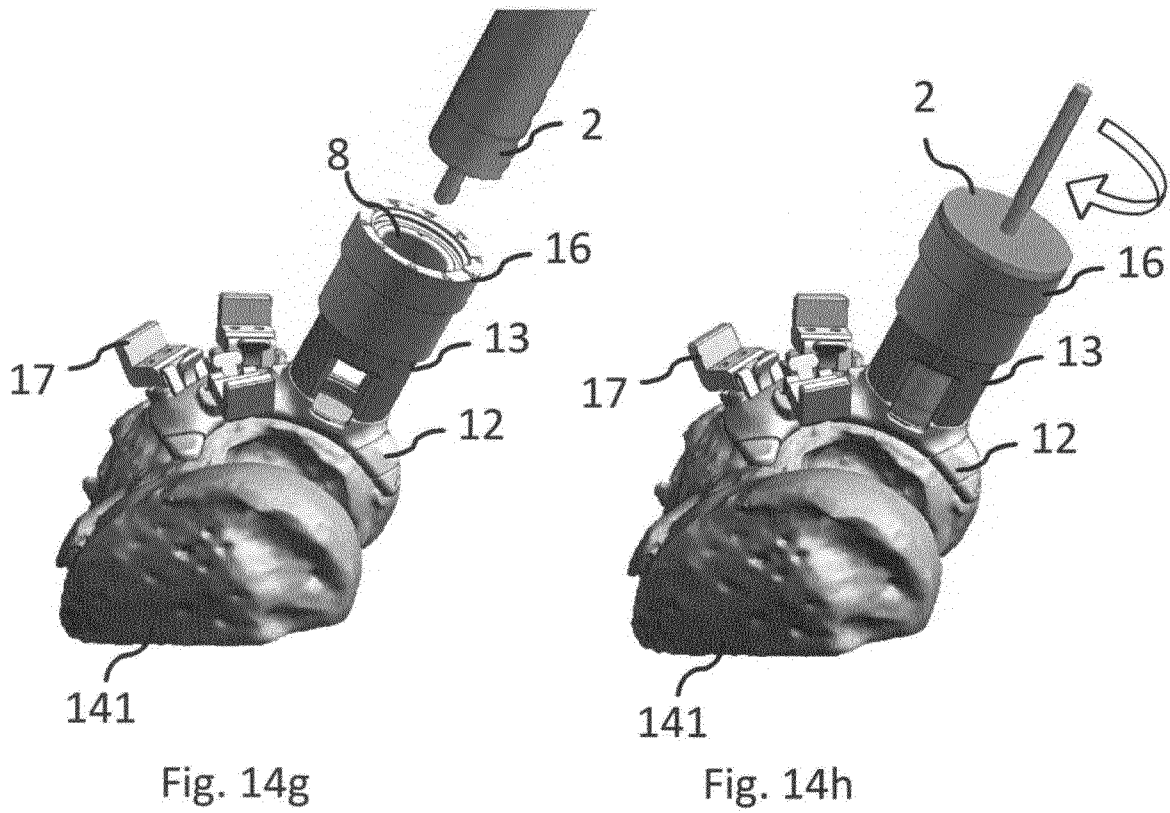
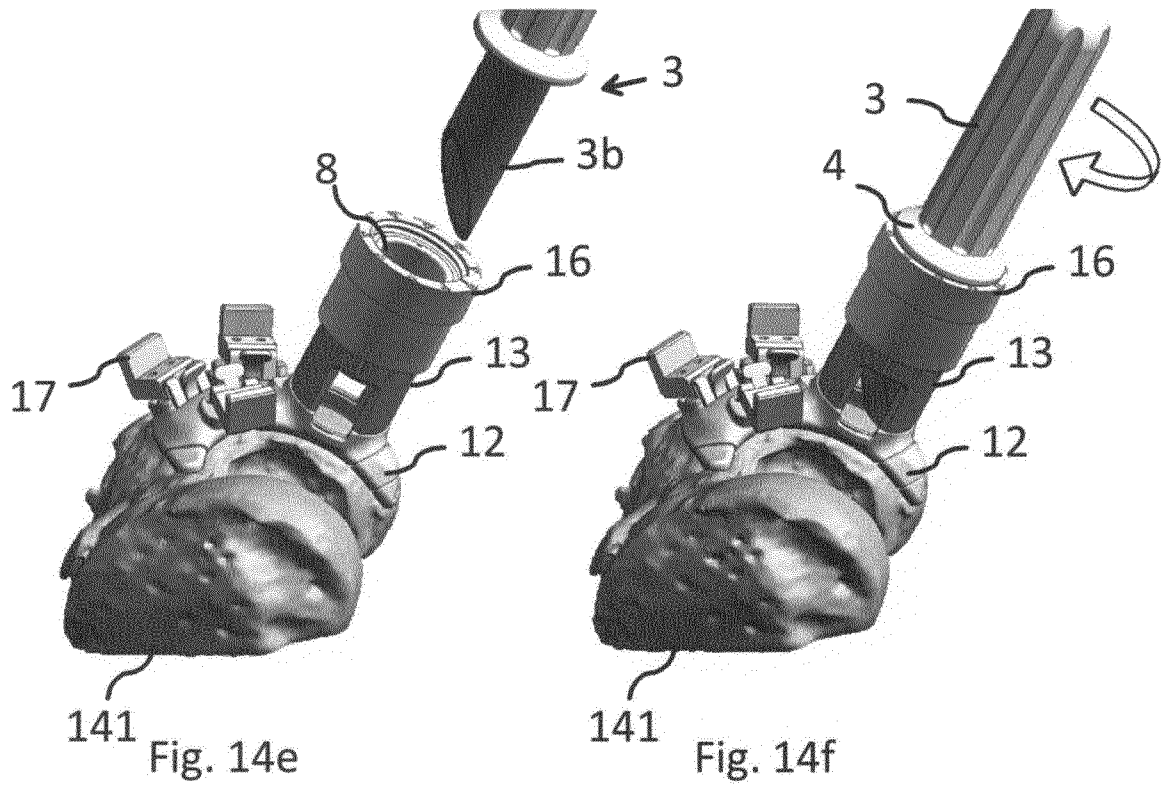

Fig. 14c

Fig. 14d

12/16



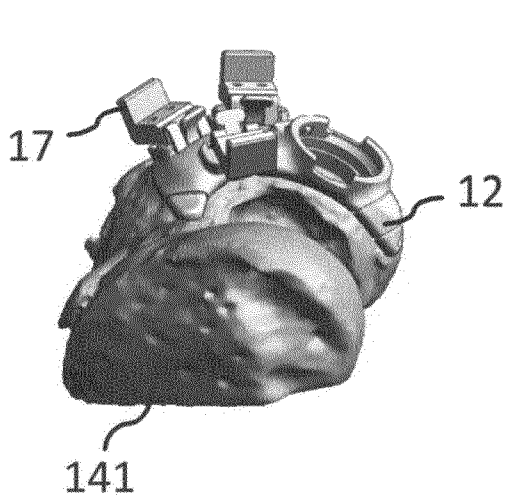

Fig. 14i

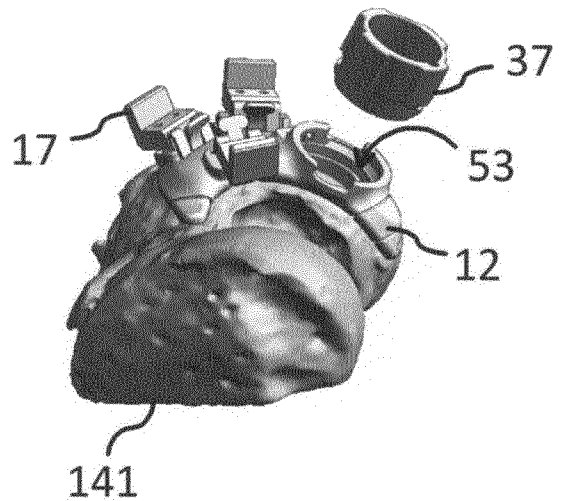

Fig. 14j

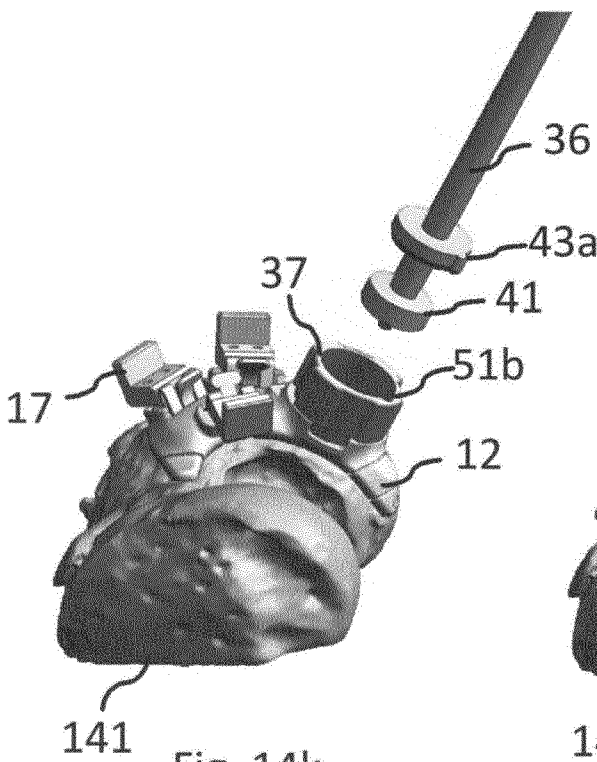

Fig. 14k

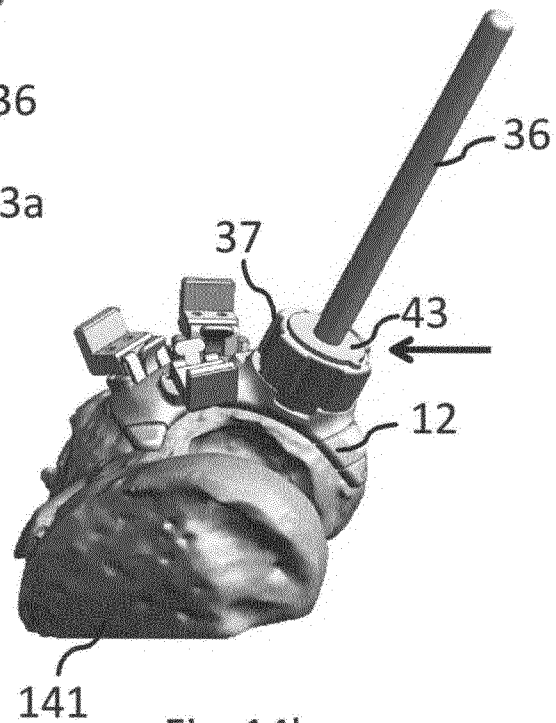
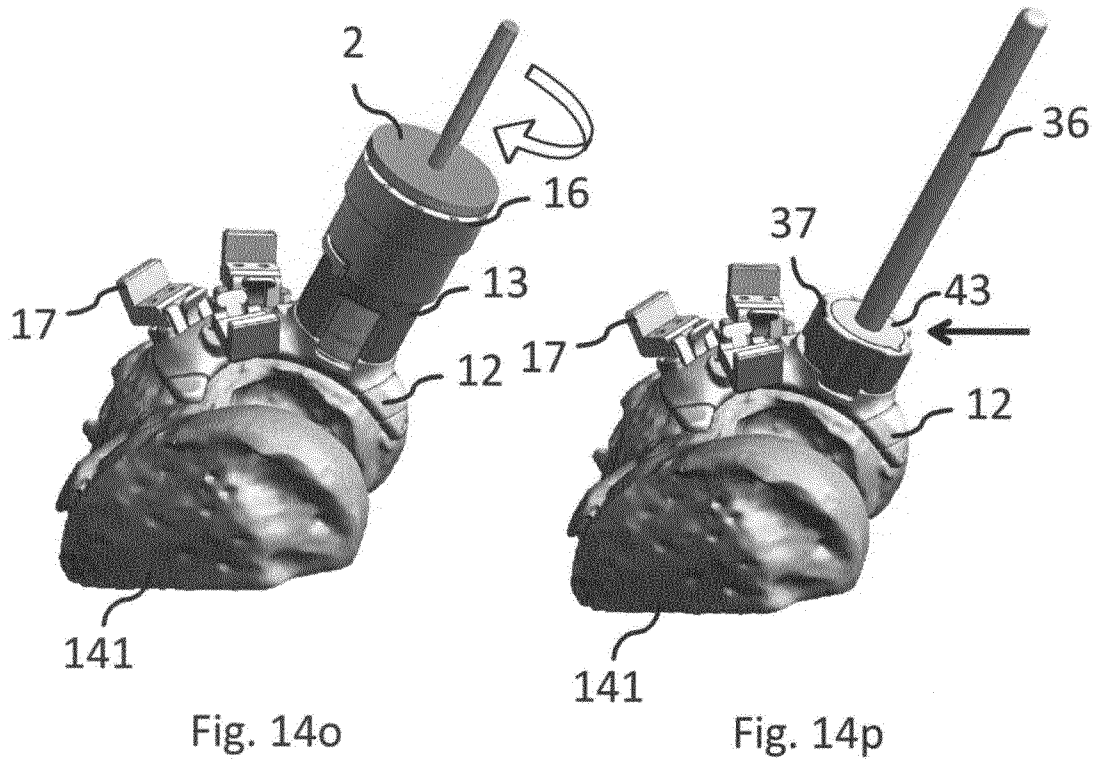
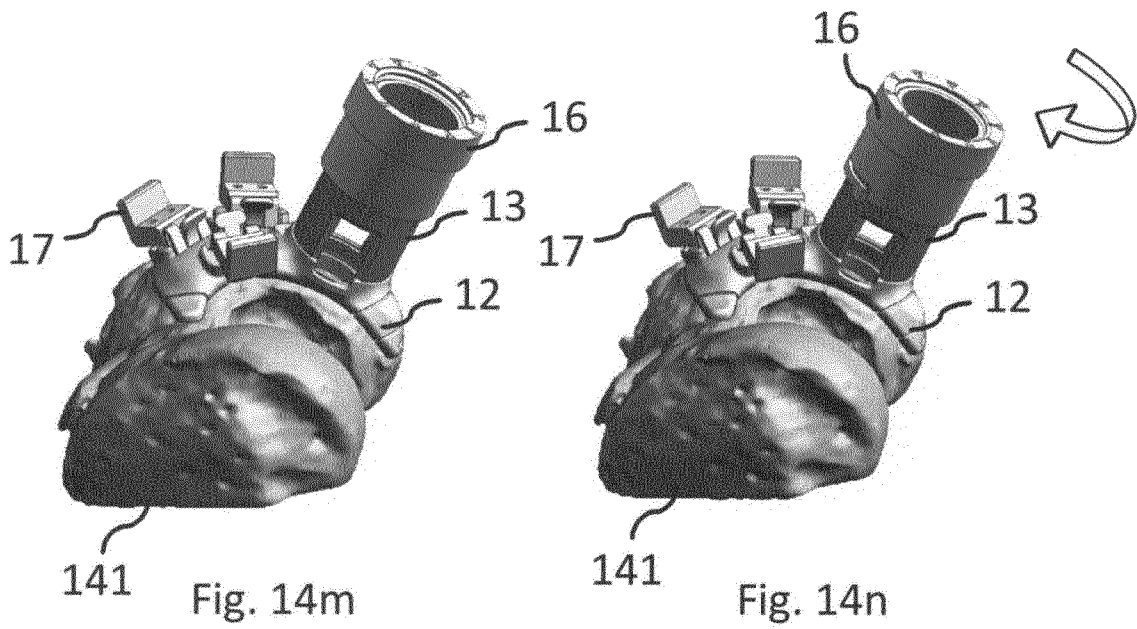
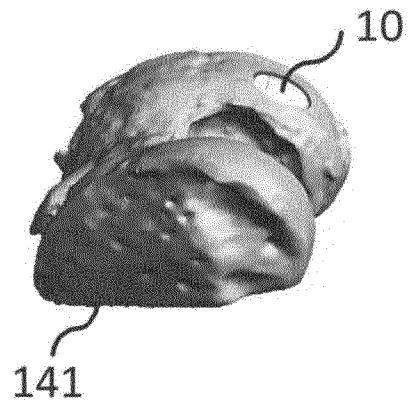
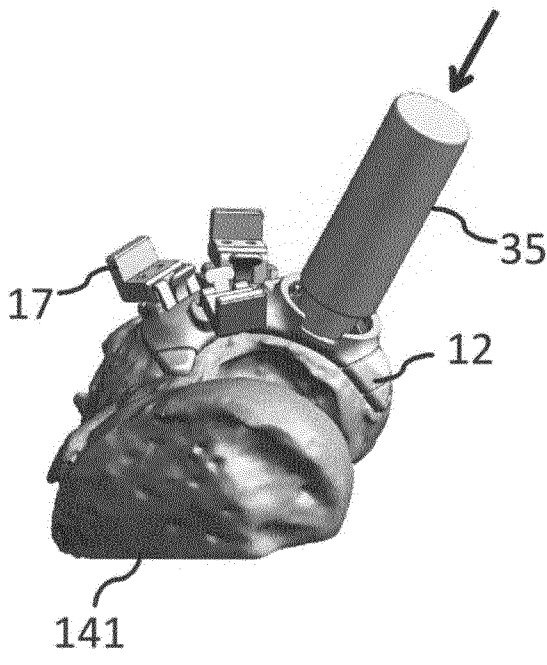
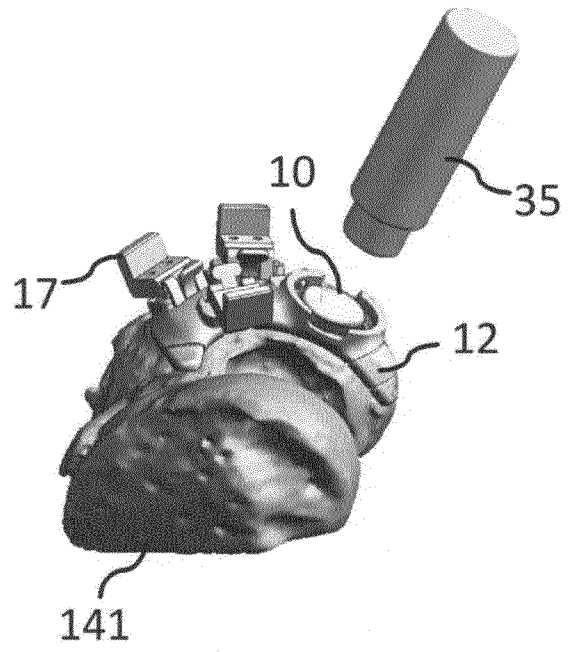
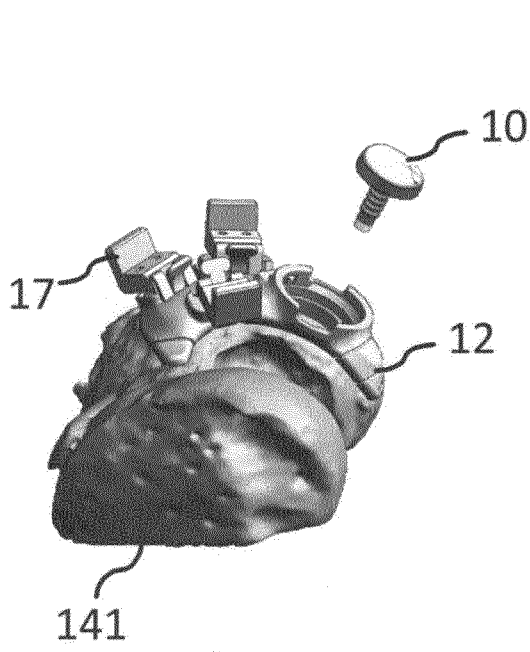

Fig. 14l

14/16



15/16



16/16

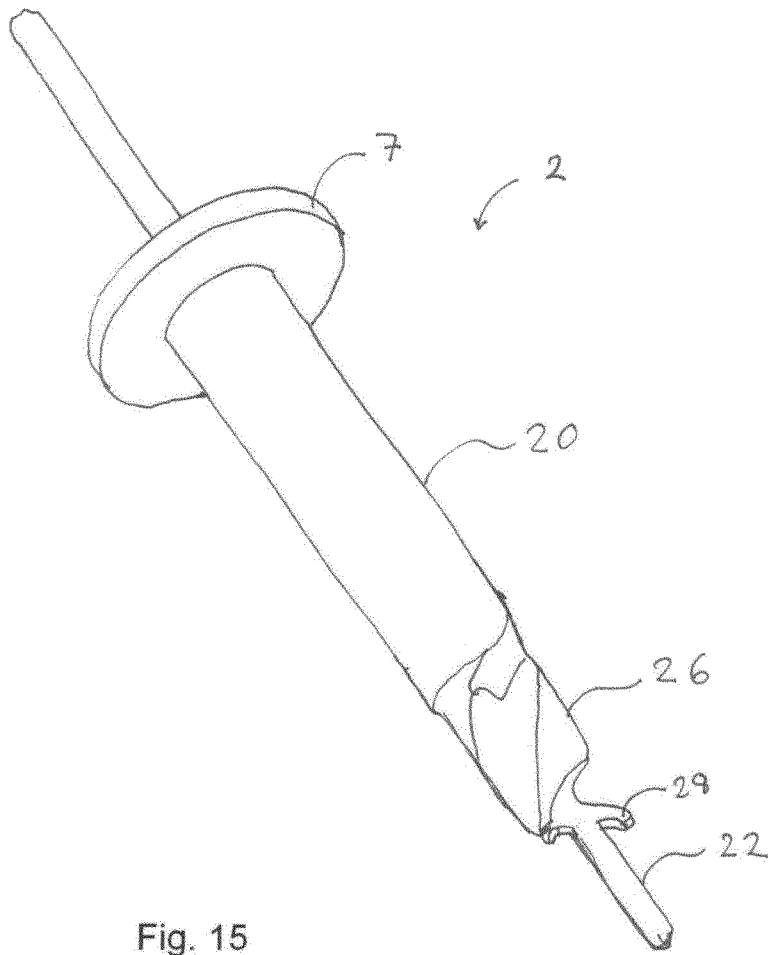

Fig. 15

INTERNATIONAL SEARCH REPORT

International application No
PCT/EP2012/067025

A. CLASSIFICATION OF SUBJECT MATTER
INV. A61B17/17 A61F2/46
ADD.
According to International Patent Classification (IPC) or to both national classification and IPC

B. FIELDS SEARCHED
Minimum documentation searched (classification system followed by classification symbols)
A61B A61F
Documentation searched other than minimum documentation to the extent that such documents are included in the fields searched

Electronic data base consulted during the international search (name of data base and, where practicable, search terms used)
EPO-Internal

C. DOCUMENTS CONSIDERED TO BE RELEVANT

Category*	Citation of document, with indication, where appropriate, of the relevant passages	Relevant to claim No.
X	US 2002/116006 A1 (COHEN HERB [US]) 22 August 2002 (2002-08-22)	1,2,6,8, 9,11,14
Y	figures 6, 7	3
Y	----- WO 2011/063257 A1 (KNEE CREATIONS LLC [US]; BAGGA CHARANPREET S [US]; HANSON SHAUN B [US]) 26 May 2011 (2011-05-26) figures 4A-10I	3
A	----- WO 2008/138137 A1 (UNIV KINGSTON [CA]; KUNZ MANUELA [CA]; RUDAN JOHN F [CA]) 20 November 2008 (2008-11-20) paragraph [0116] - paragraph [0121]; figures 14-15b	15
A	----- US 2008/243127 A1 (LANG PHILIPP [US] ET AL) 2 October 2008 (2008-10-02) figure 7D	15

Further documents are listed in the continuation of Box C. See patent family annex.

* Special categories of cited documents :

"A" document defining the general state of the art which is not considered to be of particular relevance	"T" later document published after the international filing date or priority date and not in conflict with the application but cited to understand the principle or theory underlying the invention
"E" earlier application or patent but published on or after the international filing date	"X" document of particular relevance; the claimed invention cannot be considered novel or cannot be considered to involve an inventive step when the document is taken alone
"L" document which may throw doubts on priority claim(s) or which is cited to establish the publication date of another citation or other special reason (as specified)	"Y" document of particular relevance; the claimed invention cannot be considered to involve an inventive step when the document is combined with one or more other such documents, such combination being obvious to a person skilled in the art
"O" document referring to an oral disclosure, use, exhibition or other means	"&" document member of the same patent family
"P" document published prior to the international filing date but later than the priority date claimed	

Date of the actual completion of the international search 8 January 2013	Date of mailing of the international search report 17/01/2013
--	---

Name and mailing address of the ISA/ European Patent Office, P.B. 5818 Patentlaan 2 NL - 2280 HV Rijswijk Tel. (+31-70) 340-2040, Fax: (+31-70) 340-3016	Authorized officer Fernández Arillo, J
--	--

INTERNATIONAL SEARCH REPORT

International application No.
PCT/EP2012/067025

Box No. II Observations where certain claims were found unsearchable (Continuation of item 2 of first sheet)

This international search report has not been established in respect of certain claims under Article 17(2)(a) for the following reasons:

1. Claims Nos.:
because they relate to subject matter not required to be searched by this Authority, namely:

2. Claims Nos.:
because they relate to parts of the international application that do not comply with the prescribed requirements to such an extent that no meaningful international search can be carried out, specifically:

3. Claims Nos.:
because they are dependent claims and are not drafted in accordance with the second and third sentences of Rule 6.4(a).

Box No. III Observations where unity of invention is lacking (Continuation of item 3 of first sheet)

This International Searching Authority found multiple inventions in this international application, as follows:

see additional sheet

1. As all required additional search fees were timely paid by the applicant, this international search report covers all searchable claims.
2. As all searchable claims could be searched without effort justifying an additional fees, this Authority did not invite payment of additional fees.
3. As only some of the required additional search fees were timely paid by the applicant, this international search report covers only those claims for which fees were paid, specifically claims Nos.:

1-3, 6, 8, 9, 11, 14, 15
4. No required additional search fees were timely paid by the applicant. Consequently, this international search report is restricted to the invention first mentioned in the claims; it is covered by claims Nos.:

Remark on Protest

- The additional search fees were accompanied by the applicant's protest and, where applicable, the payment of a protest fee.
- The additional search fees were accompanied by the applicant's protest but the applicable protest fee was not paid within the time limit specified in the invitation.
- No protest accompanied the payment of additional search fees.

FURTHER INFORMATION CONTINUED FROM PCT/ISA/ 210

This International Searching Authority found multiple (groups of) inventions in this international application, as follows:

1. claims: 1-3, 6, 8, 9, 11, 14

The surgical kit of claim 1, wherein the guide body further comprises two guide channels (claim 3), thereby solving the problem of allowing the kit to be used simultaneously with two different implants or plugs.

2. claim: 4

The surgical kit of claim 1, wherein the guide channel is provided by a guide insert (claim 4), thereby solving the problem of increasing the modularity of the kit (the body can be made e.g. of a lighter material and the insert of metal).

3. claim: 5

The surgical kit of claim 1, further comprising one breakage means (claim 5), thereby solving the problem of allowing easy removal of part of the positioning device by tearing.

4. claim: 7

The surgical kit of claim 6, further comprising adaptors (claim 7), thereby solving the problem of enabling flexible attachment of the positioning body to the bone.

5. claim: 10

A surgical kit according to claim 8, wherein the insert tool is a drill and bone remover, for solving the problem of preparing the bone to receive an implant with an extending post.

6. claims: 12, 13

A surgical kit according to claim 1, further comprising an implant dummy (claim 12), for solving the problem of checking if the hole drilled corresponds to the implant to be implanted.

7. claim: 15

A method for designing the surgical kit of claim 1, for solving the problem of designing a modular patient-specific surgical kit in a more precise manner.

INTERNATIONAL SEARCH REPORT

Information on patent family members

International application No PCT/EP2012/067025

Patent document cited in search report	A1	Publication date	Patent family member(s)	Publication date
US 2002116006	A1	22-08-2002	EP 1361826 A1	19-11-2003
			US 2002116006 A1	22-08-2002
			WO 02067786 A1	06-09-2002

WO 2011063257	A1	26-05-2011	AU 2010321812 A1	12-07-2012
			CN 102740789 A	17-10-2012
			EP 2501314 A1	26-09-2012
			KR 20120112470 A	11-10-2012
			US 2011125160 A1	26-05-2011
			WO 2011063257 A1	26-05-2011

WO 2008138137	A1	20-11-2008	AU 2008250951 A1	20-11-2008
			CA 2687116 A1	20-11-2008
			CN 101742972 A	16-06-2010
			EP 2157926 A1	03-03-2010
			JP 2010526605 A	05-08-2010
			US 2008287954 A1	20-11-2008
			WO 2008138137 A1	20-11-2008

US 2008243127	A1	02-10-2008	US 2008243127 A1	02-10-2008
			US 2008281328 A1	13-11-2008
			US 2008281329 A1	13-11-2008
			US 2008281426 A1	13-11-2008
			US 2010305573 A1	02-12-2010
			US 2010305574 A1	02-12-2010
			US 2011066193 A1	17-03-2011
			US 2011071581 A1	24-03-2011
			US 2011295329 A1	01-12-2011
			US 2012101503 A1	26-04-2012
			US 2012143197 A1	07-06-2012
