



- (51) International Patent Classification:
D06F 39/02 (2006.01) *A47L 15/44* (2006.01)
- (21) International Application Number:
PCT/EP2011/065938
- (22) International Filing Date:
14 September 2011 (14.09.2011)
- (25) Filing Language: English
- (26) Publication Language: English
- (71) Applicant (for all designated States except US): **ECOLAB INC.** [US/US]; 370 Wabasha Street N, St. Paul, Minnesota 55102-1390 (US).
- (72) Inventor; and
- (75) Inventor/Applicant (for US only): **DE BRABANTER, Dirk** [BE/BE]; Trapstraat 9, B-1674 Bellingen (BE).
- (74) Agent: **MICHALSKI HÜTTERMANN & PARTNER PATENTANWÄLTE**; Michalski, Stefan (Association No. 289), Neuer Zollhof 2, 40221 Düsseldorf (DE).
- (81) Designated States (unless otherwise indicated, for every kind of national protection available): AE, AG, AL, AM,

AO, AT, AU, AZ, BA, BB, BG, BH, BR, BW, BY, BZ, CA, CH, CL, CN, CO, CR, CU, CZ, DE, DK, DM, DO, DZ, EC, EE, EG, ES, FI, GB, GD, GE, GH, GM, GT, HN, HR, HU, ID, IL, IN, IS, JP, KE, KG, KM, KN, KP, KR, KZ, LA, LC, LK, LR, LS, LT, LU, LY, MA, MD, ME, MG, MK, MN, MW, MX, MY, MZ, NA, NG, NI, NO, NZ, OM, PE, PG, PH, PL, PT, QA, RO, RS, RU, RW, SC, SD, SE, SG, SK, SL, SM, ST, SV, SY, TH, TJ, TM, TN, TR, TT, TZ, UA, UG, US, UZ, VC, VN, ZA, ZM, ZW.

- (84) Designated States (unless otherwise indicated, for every kind of regional protection available): ARIPO (BW, GH, GM, KE, LR, LS, MW, MZ, NA, SD, SL, SZ, TZ, UG, ZM, ZW), Eurasian (AM, AZ, BY, KG, KZ, MD, RU, TJ, TM), European (AL, AT, BE, BG, CH, CY, CZ, DE, DK, EE, ES, FI, FR, GB, GR, HR, HU, IE, IS, IT, LT, LU, LV, MC, MK, MT, NL, NO, PL, PT, RO, RS, SE, SI, SK, SM, TR), OAPI (BF, BJ, CF, CG, CI, CM, GA, GN, GQ, GW, ML, MR, NE, SN, TD, TG).

Published:
— with international search report (Art. 21(3))

(54) Title: DOSING DEVICE AND METHOD FOR DOSING AT LEAST ONE FLUID

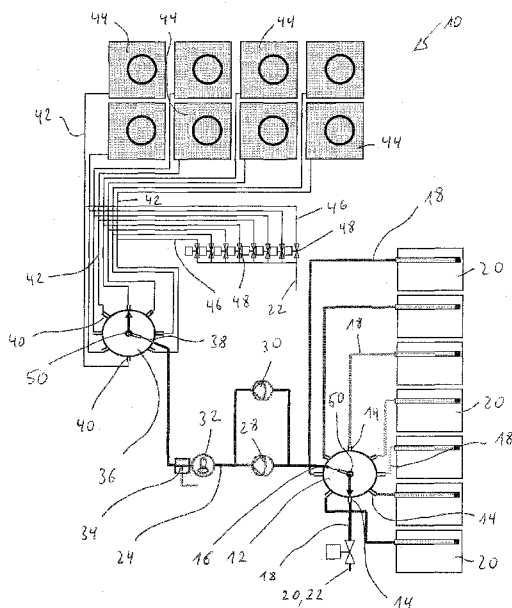

Fig. 1

(57) Abstract: A dosage system (10) for dosing one or more fluids, in particular liquid products, comprises a first dosage valve (12) comprising at least two input connectors (14) and an outlet (16), wherein the input connectors (14) are each connected to corresponding feeding lines (18) each connectable to a fluid reservoir (20), the outlet (16) is connected to a dosing line (24), which is connectable to an appliance (44), and a first pump (28) is arranged at the dosing line (24) for pumping a fluid and, whereby the first dosage valve (12) is configured to switchably connect at least one input connector (14) to the outlet (16).

WO 2013/037407 A1

5 DOSING DEVICE AND METHOD FOR DOSING AT LEAST ONE FLUID

Technical field of the invention

10 The present invention relates to a dosage system for dosing at least one fluid, in particular to at least one appliance, and an according method for dosing at least one fluid using said dosage system.

15 **Background of the invention**

Dosage systems for dosing one or more fluids for example liquid products, to one or more appliances, for example for cleaning purposes in multiple professional ware-
20 washing machines, laundry machines or the like, have to be capable of supplying one or more liquid products to the appliances. Known dosage systems for example comprise a number of valves with corresponding pumps and flow meters, for example one of each for each liquid product
25 that is to be dosed, which leads to high mechanical expenditures, and high installation and maintenance costs.

Therefore, there is a need for a dosage system, which
30 allows for a reduction in the installation and maintenance costs by reducing the mechanical expenditures.

...

- 2 -

It is therefore an object of the present invention to provide an improved dosage system for dosing a fluid, which allows for a reduction of the installation and maintenance costs. A further object of the present invention is to provide a method for dosing a fluid which comprises the use of the dosage system according to the present invention.

SUMMARY OF THE INVENTION

10

This object is solved by means of a dosage system for dosing a fluid having the features of claim 1 and by means of a method for dosing a fluid having the features of claim 11. Preferred embodiments, additional details, features, characteristics and advantages of the object of the invention of said dosage system and said method are disclosed in the subclaims.

In a general aspect of the invention the dosage system for dosing one or more fluids, in particular liquid products, comprises a first dosage valve comprising at least a first and a second input connector and an outlet, wherein the input connectors are each connected to a corresponding first and second feeding line each connectable to a fluid reservoir, and wherein the outlet is connected to a dosing line, which is connectable to an appliance, a first pump arranged at the dosing line for pumping a fluid, wherein the first dosage valve is configured to switchably connect at least one input connector to the outlet.

...

- 3 -

The first dosage valve may comprise at least a first input connector and a second input connector, in particular eight or twelve input connectors. The number of input connectors may correspond to the number of liquid products that are to be dosed by the dosage system. The input connectors are connected to a corresponding feeding line, for example the first input connector is connected to a first feeding line and the second input connector is connected to a second feeding line. The feeding lines are connectable to a corresponding fluid reservoir, wherein the first feeding line may be connected to a first fluid reservoir and the second fluid line to a second fluid reservoir. The fluids, in particular the liquid products, are supplied to the first dosage valve from the fluid reservoir, through the corresponding feeding line and the corresponding input connector, to which the feeding line is connected. The fluids that are to be dosed may, for example be water and/or liquid products, wherein the liquid products may be alkaline products and/or acidic products. The first dosage valve comprises an outlet, which is connected to a dosing line, which may be connected to an appliance, for example a multiple professional ware-washing machine or a laundry machine. The first dosage valve may switchably connect one input connector directly fluid permeable to the outlet, for example the first input connector, to the outlet. The first dosage valve may be switched for example to the second input connector in order to connect the second feeding line via the second input connector to the outlet, in order for a fluid to be pumped from the second fluid reservoir, through the second feeding line, through

...

- 4 -

the dosing line and a first pump attached to the dosing line, for example to an appliance. This allows for dosing one or more fluids to at least one appliance. The first pump arranged at the dosing line for pumping the fluid
5 may for example be a diaphragm pump. The fluid may be sucked through the first dosage valve by an underpressure exerted on to the first dosage valve by the first pump. The first dosage valve may for example be at least partially made out of polypropylene (PP) for use with
10 alkaline liquid products, and out of polyvinylidene fluoride (PVDF) for use with acidic fluid products.

The dosage system according to the present invention has the advantage, that for dosing one or more fluids, in
15 particular liquid products, for example only one dosage valve with a first pump is needed. Thus, the number of for example pumps and flow meters may be significantly reduced, due to which the mechanical expenditures may also be reduced, which leads to a reduction in the
20 installation and maintenance costs.

In another embodiment of the dosage system the dispensing system further comprises a second dosage valve comprising at least a first and a second output connector and at
25 least one inlet, wherein the at least one inlet is connected to the dosing line, and wherein the output connectors are each connected to a corresponding first and second discharge line.

30 The second dosage valve may comprise at least one inlet, wherein the at least one inlet may be attached to the dosing line, by which a product may be pumped from the

...

- 5 -

first dosage valve to the second dosage valve. The second dosage valve may for example be at least partially made out of polypropylene (PP) for use with alkaline liquid products, and out of polyvinylidene fluoride (PVDF) for use with acidic fluid products. The fluid may be pumped from the first dosage valve by an underpressure exerted to the first dosage valve from the first pump, and may be pumped to and through the second dosage valve by a pressure created by the first pump. The second dosage valve may comprise a further inlet, for example for mixing and/or diluting the fluid supplied by the first dosage valve to the at least one inlet. The second dosage valve further comprises at least a first output connector and a second output connector, wherein the first and second output connectors are each fluid permeable attached to a corresponding first and second discharge line. The first and second discharge line may be attached to a corresponding first and second appliance, for example a washing or laundry machine. The second dosage valve may comprise further output connectors corresponding to the number of appliances that are to be supplied with at least one fluid. The second dosage valve may switchably connect an input, in particular one input, directly fluid permeable to one output connector. This has the advantage, that one or more appliances may be supplied with one or more fluids, in particular liquid products, without for example increasing the number of needed pumps and flow meters. Thus, the mechanical costs may be reduced and also the installation and maintenance costs reduced.

...

- 6 -

In another embodiment of the dosage system the first and/or second dosage valve comprises a connector element, wherein the connector element is connecting an input connector to the outlet and/or the inlet to an output
5 connector. The connector element may be connected to the outlet and/or inlet for example in order to provide a continuously fluid permeable connection to the outlet and/or inlet. Further, the connector element may be moveably connected to an input connector and/or output
10 connector, in order to provide a switchable fluid permeable connection to the selected input connector and/or selected output connector. The connector element may be selectably switched to directly fluid permeable connect an input connector to the outlet and/or an output
15 connector to the inlet. This has the advantage of a cost efficient switching between different fluids, in particular liquid products, and different appliances without complicated valve racks.

20 In another embodiment of the dosage system the connector element is designed as a rotary switch. The rotary switch, for example cylindrically formed, may comprise one permanently attached or fixed end, attached to the inlet and/or outlet, wherein by rotating of at least a
25 part of the rotary switch a selected input connector and/or a selected output connector may be selectively directly fluid permeable connected to the outlet and/or inlet. The rotary switch allows for a simplified design of the dosage valves, further reducing the mechanical
30 expenses and increasing the cost efficiency of the dosage system. Further, the needed installation space may be reduced.

...

- 7 -

In another embodiment of the invention the first and/or second dosage valve comprises a valve manifold, wherein the valve manifold is connecting an input connector to the outlet and/or the inlet to an output connector. The valve manifold may be connected to at least a first and a second input and/or output connector, wherein the valve manifold comprises a feeding valve allocated to each input and/or output connector for selectably connecting one input and/or output connector to one outlet and/or inlet. The valve manifold, in particular the according feeding valve, may be selectably switched to directly fluid permeable connect an input connector to the outlet and/or an output connector to the inlet. The number of feeding valves of the valve manifold of the first dosage valve may correspond to the number of input connectors and/or feeding lines and/or the number of liquid products to be dosed. The number of feeding valves of the valve manifold of the second dosage valve may correspond to the number of output connectors and/or appliances to be supplied with a fluid. The valve manifold may be designed as a valve manifold block. The valve manifold has the advantage of a simple design allowing for a cost efficient switching between different fluids, in particular liquid products.

Furthermore, in another embodiment of the dosage system at least one feeding line is connected to a fluid reservoir in form of a water supply, in particular a water main. The at least one feeding line connected to a water reservoir, in particular connected to a water main, may comprise a water valve for controlling the flow of

...

- 8 -

water, in order to be able to close the feeding line and separate the water reservoir from the first dosage valve. The water main may be potable water, centrally supplied to a building for example. The connection of a feeding
5 line to a water reservoir has the advantage, that by selecting this feeding line and connecting it to the outlet of the first dosage valve it is possible to flush the dosage system at least partially, for example before selecting a different fluid to be dosed, in order to
10 avoid unwanted chemical reactions inside the dosage system. Further, it is possible to either flush a certain amount of dosed fluid faster to for example an appliance and/or supply a certain amount of water to an appliance, for example a laundry machine, for diluting a dosed
15 product.

In a further embodiment of the dosage system at least one flushing line is connected to the dosing line and/or at least one discharge line. A flushing line may be
20 connected for example to a fluid supply and may comprise a flushing valve for controlling the amount of fluid that is supplied through the flushing line. The fluid supply may be a water supply or a gas supply, wherein the water supply may be a water main, and the gas supply may be a
25 pressurized air supply. A flushing line may be connected to the dosing line, for example for at least partially flushing the dosing line and/or the first pump. Further, it is possible to either flush a certain amount of dosed fluid faster to an appliance, for example by air or
30 water, and/or supply for example a certain amount of water to an appliance, for example a laundry machine, for diluting a dosed product. At least one flushing line may

...

- 9 -

be connected to at least one discharge line, for example in order to flush a certain amount of dosed fluid faster to an appliance and/or supply a certain amount of water to an appliance, in particular a laundry machine, for
5 diluting a dosed product. One flushing line may be attached to several discharge lines, or one flushing line may be connected to each discharge line, wherein each flushing line comprises a flushing valve.

10 In another embodiment of the dosage system a second pump is provided. The second pump may be a diaphragm pump creating an underpressure at the first dosage valve for sucking a fluid from a fluid reservoir, and pumping the fluid to an appliance, in particular through a second
15 dosage valve. The second pump may be arranged parallel to the first pump at the dosing line. This has the advantage of having a backup pump in case the first pump fails, and/or the possibility to increase the amount of fluid that is pumped to an appliance.

20

In another embodiment of the dosage system a flow meter is arranged at the dosing line for measuring the amount of fluid pumped through the dosing line. The flow meter may be a gear meter. Further, at the dosing line a safety
25 valve, for example in the direction of flow of a fluid, behind the flow meter may be provided in order to expel the fluid to a drain in case of a blockage. The flow meter at the dosing line allows for measuring an amount of any fluid that is pumped to an appliance, thus
30 reducing the mechanical expenditures and reducing the installation and maintenance costs of the dosage system.

...

- 10 -

In further embodiment of the dosage system at least one fluid reservoir is a canister. At least one fluid reservoir may be designed in form of a canister or a drum, in particular a product drum. This allows for providing separate fluids, in particular liquid products, in separate canisters, connectable to the feeding lines. This has the advantage of improved handling and supplying of the fluids, in particular liquid products. Also it is possible, for example if two feeding lines provide the same product from a first and a second canister, that after the first canister has been emptied, the fluid is supplied by the second canister after switching the feeding lines accordingly whilst the first canister may be exchanged.

15

A further aspect of the present invention is a method for dosing one or more fluids, comprising the steps of connecting a first feeding line fluid permeable to a dosing line by connecting a first input connector to an outlet of the first dosage valve of the above described dosage system, continuously or discontinuously pumping a fluid from the first feeding line to an appliance, optionally connecting a second feeding line fluid permeable to the dosing line by connecting a second input connector to the outlet of the first dosage valve.

A first feeding line may be connected to a dosing line for supplying a first fluid to a first appliance by connecting the first feeding line, in particular a first input connector, to an outlet of the first dosage valve. The first feeding line may be connected to the dosing line by accordingly switching the first dosage valve, for

...

- 11 -

example rotating a connector element or by operating a valve manifold. By starting a first pump, for example arranged at the dosing line, an underpressure may be created at the first dosage valve in order to suck the first fluid from a first fluid reservoir through the first feeding line and the first dosage valve, further pumping the first fluid through the dosing line to an appliance. The first fluid may be pumped continuously or discontinuously from the first fluid reservoir to the first appliance. The first dosage valve may be switched to a second feeding line, connectable to a second fluid reservoir, if desired, in particular when the first pump is stopped, in order to supply a second fluid to for example the first appliance. When switching the first dosage valve from the first to the second feeding line the first input connector will be disconnected from and a second input connector will be connected to the outlet of the first dosage valve. The switching may be performed for example by rotating the connector element or operating the valve manifold of the first dosage valve. This has the advantage that one dosage valve, in particular the first dosage valve, may connect any input connector to the outlet and hence the dosing line, supplying one or more fluids to an appliance. Thus, reducing the mechanical expenditures and reducing the installation and maintenance costs.

In another embodiment the method further comprises the step of connecting the dosing line to a discharge line by connecting an inlet to an output connector of a second dosage valve. A second dosage valve may comprise an inlet connected to the dosing line and at least a first and a

...

- 12 -

second output connector, connected to a first and a second discharge line connectable to a first and a second appliance. The inlet may be connected to an output connector, for example by rotating a connector element or
5 operating a valve manifold of the second dosage valve, wherein the selected output connector, and thus the corresponding discharge line, is fluid permeable connected to the inlet of the second dosage valve. The inlet of the second dosage valve may be connected to any
10 output connector of the second dosage valve. This has the advantage, that any fluid being supplied to the second dosage valve through the dosing line may be selectably supplied to any appliance connected to an output connector via a corresponding discharge line. This has
15 the advantage of distributing a fluid, in particular a liquid product, supplied to the second dosage valve to one or more appliances, connected to the second dosage valve, with one dosage valve. Thus, the mechanical expenditures may be reduced.

20

In another embodiment the method further comprises the step of flushing the first and or second dosage valve and the dosing line and/or discharge line. A feeding line of the first dosage valve may be connected to a water
25 reservoir, for example a water main. By switching the first dosage valve to the feeding line supplying water, when starting the pump, water may be pumped through the first dosage valve to an appliance, flushing the dosage system, for example after supplying a first fluid and
30 prior to supplying a second fluid to an appliance. This has the advantage, that the dosing line and/or a connected discharge line may be flushed together,

...

- 13 -

enabling an increased transport of a fluid to an appliance and/or the adding of an extra amount of for example water to an appliance.

5 In a further embodiment the method further comprises the step of additionally flushing of at least a portion of a discharge line. At least one flushing line may be connected to one or more discharge lines. By operating a corresponding flushing valve a fluid from a fluid supply
10 may be flushed through the corresponding discharge line, in particular without pumping from a first and/or second pump at the dosing line, towards a corresponding appliance. The fluid supply may be a water supply, for example a water main, or a gas supply, for example a
15 pressurized air supply. The flushing line may be attached to one or more discharge lines and/or a separate flushing line, in particular with a corresponding flushing valve, may be attached to each discharge line. A flushing line may be activated in particular by operating a
20 corresponding flushing valve of the flushing line connected to the discharge line. This has the advantage that the selected discharge line or lines may be flushed together and/or independently, enabling an increased transport of a fluid to an appliance and/or the adding of
25 an extra amount of for example water to an appliance.

In another embodiment the method further comprises the step of measuring the amount of fluid pumped through the dosing line by a flow meter. A flow meter enables the
30 measurement of an amount of fluid pumped through the dosing line, thus enabling a precise dosing of a fluid to an appliance. Further, the amount of fluid measured by

...

- 14 -

the flow meter may be used in order to activate or deactivate the pump, depending on the amount of fluid to be dosed. The flow meter may be connected to and controlled by a control unit. If the flow meter is measuring no flow of a fluid even if the pump is running, a blockage may have occurred and a safety valve may be operated in order to avoid a pressure build up and damage to the dosage system. This allows for an automated and safe operation of dosing a fluid to an appliance.

10

The afore mentioned components, as well as the claimed components and the components to be used in accordance with the invention in the described embodiments, are not subject to any special exceptions with respect to their size, shape, material selection and technical concept such that the selection criteria known in the pursuant field can be applied without a limitation.

DESCRIPTION OF THE FIGURES

20

Additional details, features, characteristics and advantages of the object of the invention are disclosed in the figures and the following description of the respective figures, which - in exemplary fashion - show one embodiment and an example of a dosage system according to the invention. In the drawings:

Fig. 1 shows a schematically illustration of an embodiment of the dosage system.

30

The illustration in Fig. 1 shows an embodiment of the dosage system 10 for dosing one or more fluids according

...

- 15 -

to the present invention. In Fig. 1 a first dosage valve 12, comprising eight input connectors 14 and one outlet 16 is shown. The input connectors 14 are connected to feeding lines 18, which are connected to corresponding fluid reservoirs 20. One of the fluid reservoirs 20 is configured as a water supply in form of a water main 22 comprising a water valve 24 for opening or closing the water supply. The remaining feeding lines 18 are connected to fluid reservoirs 20 in form of canisters or drums. The fluid reservoirs 20 may contain the same or different fluids, for example may two fluid reservoirs 20 comprise the same fluid in order to allow for a continuous supply of the fluid, in case one fluid reservoir 20, in particular canister, needs to be exchanged. Also the fluid reservoirs 20 may comprise each different fluids, for example liquid products. A fluid may be pumped through a dosing line 24 towards at least one appliance 26 by a first pump 28.

The first pump 28 may create an underpressure inside at least part of the dosing line 24, the first dosage valve 12, the selected feeding line 18, allowing a fluid to be sucked from a corresponding fluid reservoir 20. A second pump 30 may be installed parallel to the first pump 28 in order to increase the amount of pumped fluid or in order to replace the first pump 28 in case of a malfunction of the first pump 28. The first and/or second pump may be able to pump about 50 litres per hour. The fluid is pumped by the pressure of the first and/or second pump 28,30 through the dosing line 24, wherein a flow meter 32 measures the amount of fluid pumped through the dosing line. A safety valve 34, which may be a pressure valve,

...

- 16 -

is integrated into the dosing line 24 in order to prevent a pressure build up, possibly damaging the dosage system 10, in case of a blockage for example. The fluid is pumped through the dosing line 24 to a second dosage valve 36. The second dosage valve 36 comprises one inlet 38, connected to the dosing line 24, and eight output connectors 40, each connected to a corresponding discharge line 42, connected to a corresponding appliance 44, for example a laundry machine. To each discharge line 42 a flushing line 46 with a corresponding flushing valve 48 is connected. The flushing lines 46 are connected to a water main 22 or a pressurized air supply. This allows for an independent and/or simultaneous at least partial flushing of each discharge line 42, for example to flush a dosed fluid faster into a corresponding appliance 44 by water or pressurized air, and/or to supply an extra amount of water to an appliance 44, for example for diluting the dosed fluid.

The first and second dosage valve 12,36 each comprise a connector element 50 for connecting alternatively switchable one input connector 14 with the outlet 16 and/or the inlet 38 with one output connector 40. The connector element 50 may be designed in form of a rotary switch, wherein the connector element 50, in particular the rotary switch, may be at least partially rotatable. The connector element 50 of the first dosage valve 12 is permanently fluid permeable connected to the outlet 16 and alternatively connectable to any of the input connectors 14. The connector element 50 of the second dosage valve 36 is permanently fluid permeable connected to the inlet 38 and alternatively connectable to any of

...

- 17 -

the output connectors 40. The connector element 50 of the first dosage valve 12 is connecting a feeding line 18, which is connected to a water main, to the outlet 16 of the first dosage valve 12. The connector element 50 of the second dosage valve 36 connects the inlet 38 to one of the output connectors 40, connected to an appliance 44 by a corresponding discharge line 42. This allows, if the water valve 22 is opened and the pump 28,30 operated, a fluid, in particular water, for example to be dosed through the first dosage valve 12, in particular the connector element 50 of the first dosage valve 12, the dosing line 24, the second dosage valve 36, in particular the connector element 50 of the second dosage valve 36, through the selected discharge line 42 and to a corresponding appliance 44.

The first and second dosage valves 12,36, the water valve 22, the first and second pump 28,30, the flow meter 32, the safety valve 34 and the flushing valves 22 may be connected to a control unit (not shown) and may be operated by the control unit. The appliances 44 may also be connected to and operated by the control unit.

The particular combinations of elements and features in the above detailed embodiments are exemplary only; the interchanging and substitution of these teachings with other teachings in this and the patents/applications incorporate by reference are also expressly contemplated. As those skilled in the art will recognize, variations, modifications, and other implementations of what is described herein can occur to those of ordinary skill in the art without departing from the spirit and the scope

...

- 18 -

of the invention as claimed. Accordingly, the foregoing description is by the way of example only and is not intending as limiting. In the claims, the wording "comprising" does not exclude other elements or steps, 5 and the identified article "a" or "an" does not exclude a plurality. The mere fact that certain measures are recited in mutually different dependent claims does not indicate that a combination of these measures cannot be used to advantage. The inventions scope is defined in the 10 following claims and the equivalents thereto. Furthermore, reference signs used in the description and claims do not limit the scope of the invention as claimed.

15

...

List of reference signs

	10	dosage system
	12	first dosage valve
5	14	input connector
	16	outlet
	18	feeding line
	20	fluid reservoir
	22	water main
10	24	dosing line
	26	appliance
	28	first pump
	30	second pump
	32	flow meter
15	34	safety valve
	36	second dosage valve
	38	inlet
	40	output connector
	42	discharge line
20	44	appliance
	46	flushing line
	48	flushing valve
	50	connector element

Claims

1. A dosage system for dosing one or more fluids, in particular liquid products, comprising:

5

a first dosage valve (12) comprising at least a first and a second input connector (14) and an outlet (16), wherein the input connectors (14) are each connected to a corresponding first and second feeding line (18) each connectable to a fluid reservoir (20), and wherein the outlet (16) is connected to a dosing line (24), which is connectable to an appliance (44),

10

a first pump (28) arranged at the dosing line (24) for pumping a fluid, wherein

15

the first dosage valve (12) is configured to switchably connect at least one input connector (14) to the outlet (16).

20

2. The dosage system according to claim 1, wherein a second dosage valve (36) comprising at least a first and a second output connector (40) and at least one inlet (38) is provided, wherein the at least one inlet (38) is connected to the dosing line (24), and wherein the output connectors (40) are each connected to a corresponding first and second discharge line (42).

25

3. The dosage system according to any of the preceding claims, wherein the first and/or second dosage valve (12,36) comprises a connector element (50), wherein the connector element (50) is connecting an input connector

30

...

- 21 -

(14) to the outlet (16) and/or the inlet (38) to an output connector (40).

4. The dosage system according to claim 3, wherein the
5 connector element (50) is designed as a rotary switch.

5. The dosage system according to any of the preceding
claims, wherein the first and/or second dosage valve
(12,36) comprises a valve manifold, wherein the valve
10 manifold is connecting an input connector (14) to the
outlet (16) and/or the inlet (38) to an output connector
(40).

6. The dosage system according to any of the preceding
15 claims, wherein at least one feeding line (18) is
connected to a fluid reservoir (20) in form of a water
supply, in particular a water main (22).

7. The dosage system according to any of the preceding
20 claims, wherein at least one flushing line (46) is
connected to the dosing line (24) and/or at least one
discharge line (42).

8. The dosage system according to any of the preceding
25 claims, wherein a second pump (30) is provided.

9. The dosage system according to any of the preceding
claims, wherein a flow meter (32) is arranged at the
dosing line (24) for measuring the amount of fluid pumped
30 through the dosing line (24).

...

- 22 -

10. The dosage system according to any of the preceding claims, wherein at least one fluid reservoir (20) is a canister.

5 11. A method for dosing one or more fluids, comprising the steps of

- connecting a first feeding line (18) fluid permeable to a dosing line (24) by connecting a first input
10 connector (14) to an outlet (16) of the first dosage valve (12) of the above described dosage system (10),

- continuously or discontinuously pumping a fluid from
15 the first feeding line (18) to an appliance (44),

- optionally connecting a second feeding line (18) fluid permeable to the dosing line (24) by connecting a second input connector (14) to the
20 outlet (16) of the first dosage valve (12).

12. The method according to claim 11, further comprising the step of connecting the dosing line (24) to a discharge line (42) by connecting an inlet (38) to an
25 output connector (40) of a second dosage valve (36).

13. The method according to claim 11 or 12, further comprising the step of flushing the first and or second dosage valve (12,36) and the dosing line (24) and/or
30 discharge line (42).

...

- 23 -

14. The method according to any of the claims 11 to 13, further comprising the step of additionally flushing of at least a portion of a discharge line (42).
- 5 15. The method according to any of the claims 11 to 14, further comprising the step of measuring the amount of fluid pumped through the dosing line (24) by a flow meter (32).

...

1/1

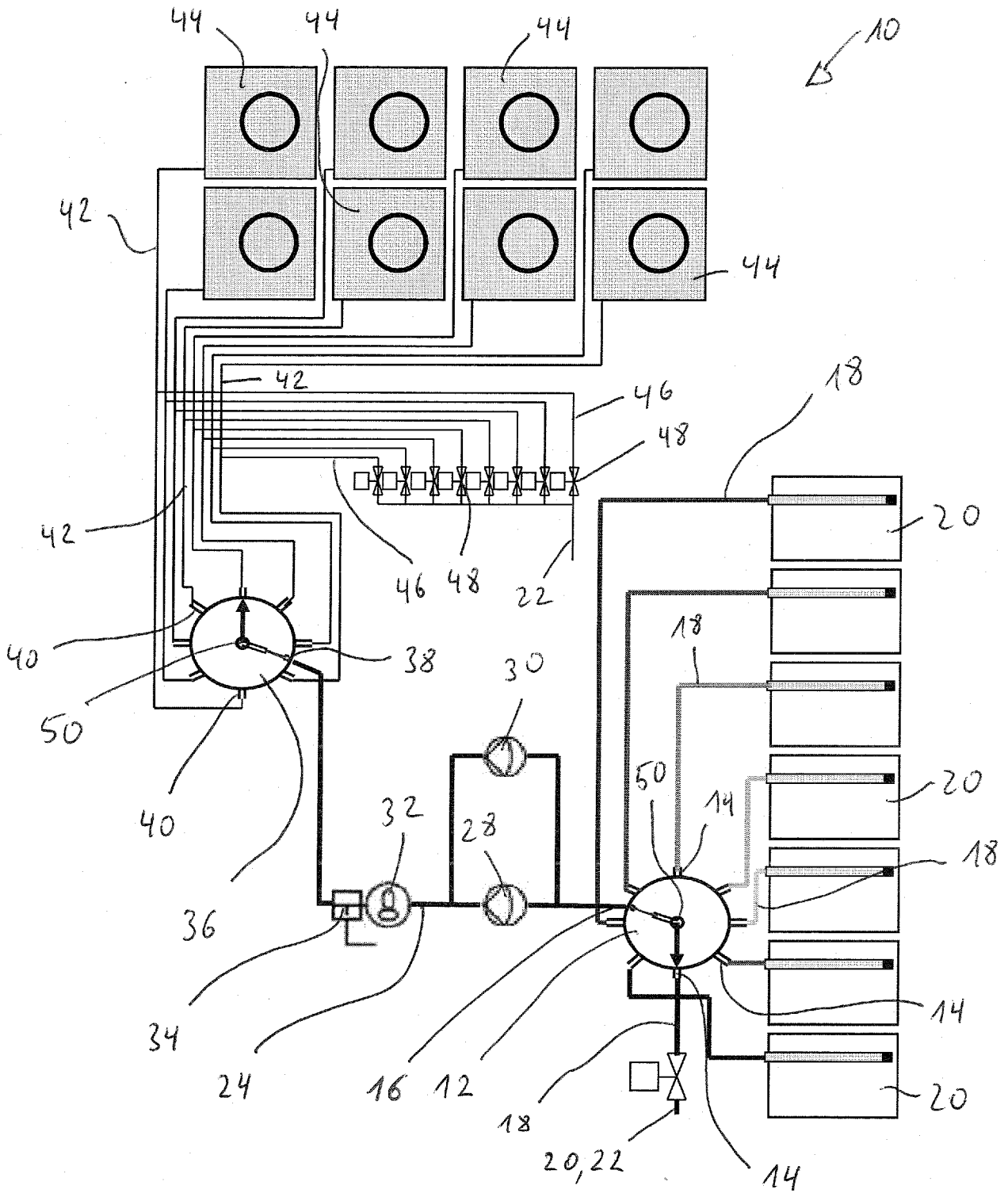

Fig. 1

INTERNATIONAL SEARCH REPORT

International application No
PCT/EP2011/065938

A. CLASSIFICATION OF SUBJECT MATTER
INV. D06F39/02 A47L15/44
ADD.
According to International Patent Classification (IPC) or to both national classification and IPC

B. FIELDS SEARCHED
Minimum documentation searched (classification system followed by classification symbols)
D06F A47L

Documentation searched other than minimum documentation to the extent that such documents are included in the fields searched

Electronic data base consulted during the international search (name of data base and, where practicable, search terms used)
EPO-Internal, WPI Data

C. DOCUMENTS CONSIDERED TO BE RELEVANT

Category*	Citation of document, with indication, where appropriate, of the relevant passages	Relevant to claim No.
X Y A	US 5 826 749 A (HOWLAND DAVID R [US] ET AL) 27 October 1998 (1998-10-27) column 1, lines 7-11; column 3, line 23 - column 4, line 28; column 7, line 52 - column 8, line 8; claims; figures	1-3,5,6, 8-10 15 4,7, 11-14
X Y A	DE 10 2007 037882 A1 (BSH BOSCH SIEMENS HAUSGERAETE [DE]) 12 February 2009 (2009-02-12) paragraphs [0001], [0014] - [0019]; claims; figures	1,3-7 13,14 2,8-12, 15
X Y A	EP 2 044 877 A1 (WHIRLPOOL CO [US]) 8 April 2009 (2009-04-08) paragraphs [0001], [0010] - [0012], [0018] - [0020], [0027]	11 13-15 1-10,12
	----- -/--	

Further documents are listed in the continuation of Box C.

See patent family annex.

* Special categories of cited documents :

- "A" document defining the general state of the art which is not considered to be of particular relevance
- "E" earlier application or patent but published on or after the international filing date
- "L" document which may throw doubts on priority claim(s) or which is cited to establish the publication date of another citation or other special reason (as specified)
- "O" document referring to an oral disclosure, use, exhibition or other means
- "P" document published prior to the international filing date but later than the priority date claimed

- "T" later document published after the international filing date or priority date and not in conflict with the application but cited to understand the principle or theory underlying the invention
- "X" document of particular relevance; the claimed invention cannot be considered novel or cannot be considered to involve an inventive step when the document is taken alone
- "Y" document of particular relevance; the claimed invention cannot be considered to involve an inventive step when the document is combined with one or more other such documents, such combination being obvious to a person skilled in the art
- "&" document member of the same patent family

Date of the actual completion of the international search 29 November 2012	Date of mailing of the international search report 07/12/2012
---	--

Name and mailing address of the ISA/ European Patent Office, P.B. 5818 Patentlaan 2 NL - 2280 HV Rijswijk Tel. (+31-70) 340-2040, Fax: (+31-70) 340-3016	Authorized officer Clivio, Eugenio
--	---

INTERNATIONAL SEARCH REPORT

International application No
PCT/EP2011/065938

C(Continuation). DOCUMENTS CONSIDERED TO BE RELEVANT		
Category*	Citation of document, with indication, where appropriate, of the relevant passages	Relevant to claim No.
A	WO 2010/070024 A1 (BSH BOSCH SIEMENS HAUSGERAETE [DE]; KRUEGER MANFRED [DE]; PROPPE WOLFG) 24 June 2010 (2010-06-24) page 11, line 22 - page 17, line 6; figures	1-15
A	----- US 2010/162774 A1 (REASON ANDREW [GB] ET AL) 1 July 2010 (2010-07-01) the whole document -----	1-15

INTERNATIONAL SEARCH REPORT

Information on patent family members

International application No

PCT/EP2011/065938

Patent document cited in search report	Publication date	Patent family member(s)	Publication date
US 5826749	A	27-10-1998	NONE

DE 102007037882	A1	12-02-2009	AT 545813 T 15-03-2012
			DE 102007037882 A1 12-02-2009
			EP 2185843 A1 19-05-2010
			PL 2185843 T3 31-07-2012
			US 2011094543 A1 28-04-2011
			WO 2009021874 A1 19-02-2009

EP 2044877	A1	08-04-2009	EP 2044877 A1 08-04-2009
			US 2009090401 A1 09-04-2009

WO 2010070024	A1	24-06-2010	DE 102008054997 A1 08-07-2010
			WO 2010070024 A1 24-06-2010

US 2010162774	A1	01-07-2010	EP 1996755 A2 03-12-2008
			EP 2420608 A1 22-02-2012
			EP 2428606 A2 14-03-2012
			JP 2009517111 A 30-04-2009
			US 2010162774 A1 01-07-2010
			US 2011167877 A1 14-07-2011
