



US 20100191284A1

(19) **United States**

(12) **Patent Application Publication**
Dreyfuss et al.

(10) **Pub. No.: US 2010/0191284 A1**

(43) **Pub. Date: Jul. 29, 2010**

(54) **FULLY THREADED SUTURE ANCHOR WITH TRANSVERSE ANCHOR PIN**

(60) Provisional application No. 60/559,425, filed on Apr. 6, 2004.

(76) Inventors: **Peter J. Dreyfuss**, Naples, FL (US);
William C. Benavitz, Naples, FL (US)

Publication Classification

(51) **Int. Cl.**
A61B 17/04 (2006.01)
B23P 11/00 (2006.01)

Correspondence Address:
Stephen A. Soffen
Dickstein Shapiro Morin & Oshinsky LLP
2101 L Street NW
Washington, DC 20037-1526 (US)

(52) **U.S. Cl. 606/232; 29/525.01**

(57) **ABSTRACT**

A suture anchor has a pin that is disposed transversely within the suture anchor, over which one or more strands of suture is looped. The anchor body is threaded and has a tapered distal portion. The proximal end portion of the suture anchor body has a hexagonally shaped opening to accept a hexagonal drive head. The peripheral surface defining hexagonally shaped opening is rounded and smooth to prevent abrading sutures placed in contact therewith.

(21) Appl. No.: **12/751,266**

(22) Filed: **Mar. 31, 2010**

Related U.S. Application Data

(63) Continuation of application No. 11/097,172, filed on Apr. 4, 2005.

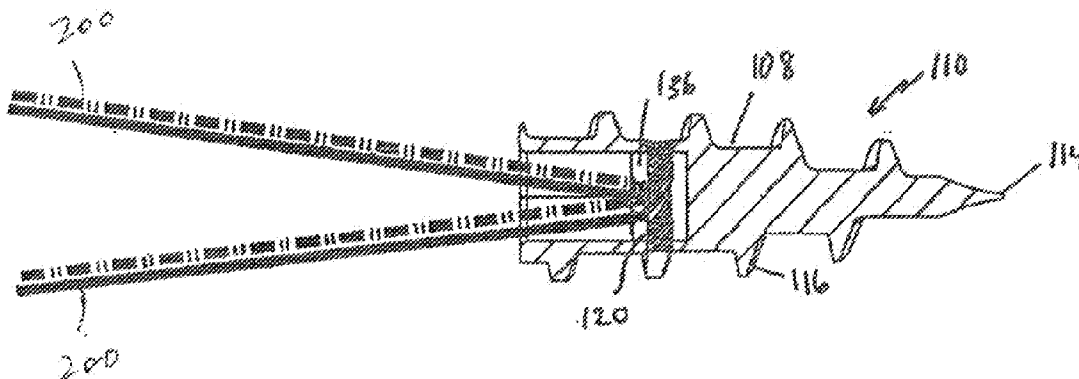

Figure 1

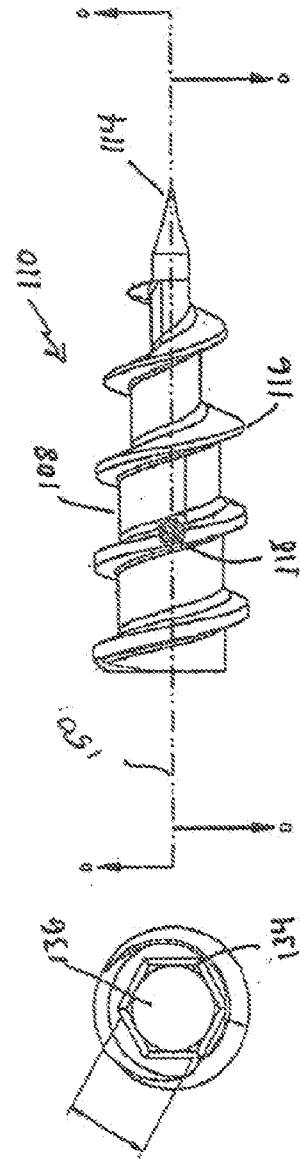

Figure 3

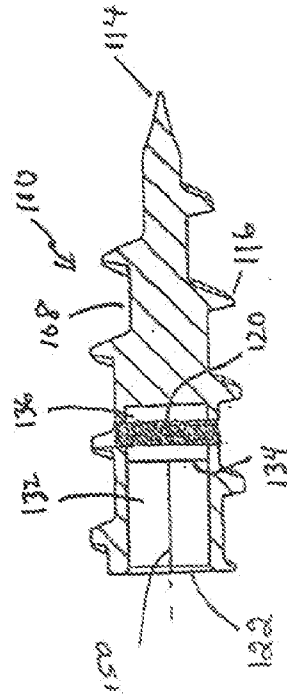
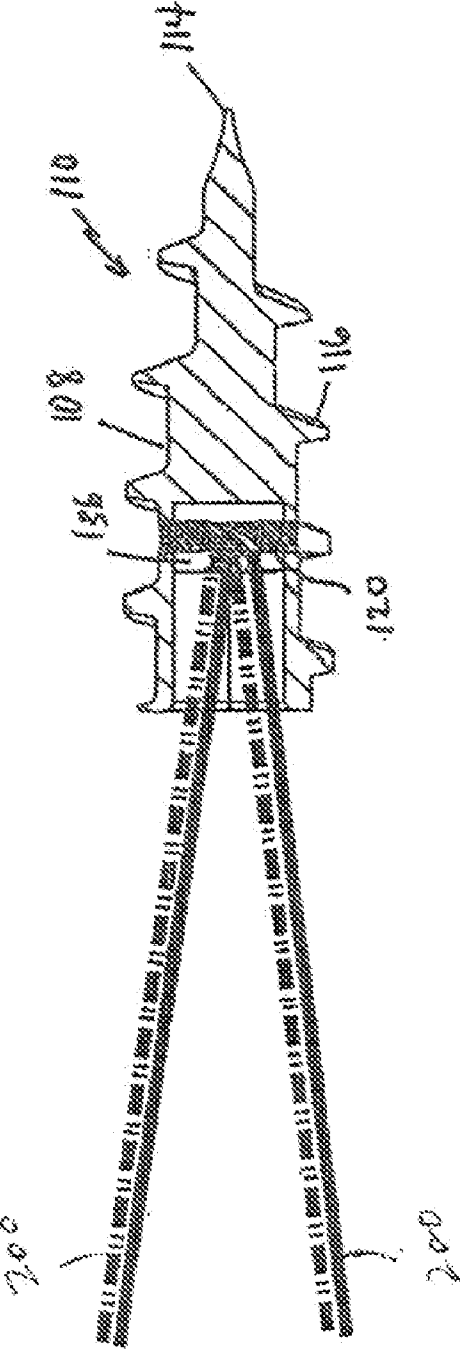

Figure 2

Figure 4.



FULLY THREADED SUTURE ANCHOR WITH TRANSVERSE ANCHOR PIN

[0001] This application is a continuation of U.S. application Ser. No. 11/097,172 filed on Apr. 4, 2005, which claims the benefit of U.S. Provisional Application No. 60/559,425, filed Apr. 6, 2004, the entire disclosure of which is incorporated by reference herein.

BACKGROUND OF THE INVENTION

Field of the Invention

[0002] The present invention relates to an apparatus for anchoring surgical suture to bone. More specifically, the present invention relates to a fully threaded suture anchor provided with a transverse anchor pin for securing, within the anchor, one or more strands of suture to anchor the suture to bone during arthroscopic surgery.

[0003] When soft tissue tears away from bone, reattachment becomes necessary. Various devices, including sutures alone, screws, staples, wedges, and plugs have been used in the prior art to secure soft tissue to bone.

[0004] Recently, various types of threaded suture anchors have been developed for this purpose. Some threaded suture anchors are designed to be inserted into a pre-drilled hole. Other suture anchors are self-tapping.

[0005] U.S. Pat. No. 4,632,100 discloses a cylindrical threaded suture anchor. The suture anchor of the '100 patent includes a drill bit at a leading end for boring a hole in a bone, followed by a flight of threads spaced from the drill bit for securing the anchor into the hole created by the drill bit.

[0006] U.S. Pat. No. 5,370,662 discloses a suture anchor having threads which extend to the tip of the anchor. U.S. Pat. No. 5,156,616 discloses a similar suture anchor having an axial opening for holding a knotted piece of suture.

[0007] All of the above-noted suture anchors include structure for attaching the suture to the anchor. U.S. Pat. No. 4,632,100, for example, discloses a press-fitted disc and knot structure which secures the suture to the anchor. In other suture anchors, such as those disclosed in U.S. Pat. No. 5,370,662, the suture is passed through an eyelet located on the proximal end of the anchor. In the case of a bioabsorbable suture anchor, the suture may be insert molded into the anchor, as disclosed in U.S. Pat. No. 5,964,783.

[0008] Problems can arise if the structure for attaching the suture fails, allowing the suture to become detached from the anchor. Also, the suture often is exposed to abrasion or cutting by sharp or rough areas along the walls of the bone canal into which the anchor is inserted.

[0009] Moreover, the eyelet or, in the case of U.S. Pat. No. 4,632,100, the axial opening for receiving the disc to which the suture is knotted, is formed as part of the drive head of the known suture anchors. Combining these two functions in one structure often tends to weaken the drive head.

[0010] In addition, various other modifications to the drive head often are employed in connection with suture attachment. For example, recessed grooves may be formed on opposite sides of the drive head to receive and protect the suture from abrasive areas of the suture anchor tunnel or to facilitate mating between the anchor to the driver. In such cases, the drive head often must be made of a larger diameter

to recover the mechanical strength lost from the removal of material relating to the suture-attachment or suture-protection modifications.

[0011] Further, the prior art suture anchors having eyelets extending from the proximal ends require countersinking of the eyelet below the bone surface to avoid having the patient's tissue abrade against the exposed eyelet. As a result, suture attached to the eyelet is vulnerable to abrasion by the bony rim of the countersunk hole into which the suture anchor is installed. In addition, in biodegradable suture anchors, the suture eyelet can degrade rapidly, causing the suture to become detached from the anchor prematurely.

[0012] Accordingly, there is a need for a threaded suture anchor to which suture is secured effectively so as to prevent detachment of the suture. It is further desirable for such suture anchors to have eyelets that will not abrade tissue and which do not require countersinking.

SUMMARY OF THE INVENTION

[0013] The suture anchor of the present invention overcomes the disadvantages of the prior art discussed above by providing a threaded suture anchor having a transverse anchor pin disposed inside the body of the suture anchor. The suture anchor is made of a biocompatible metal, preferably a titanium alloy.

[0014] The proximal end surface of the threaded suture anchor of the present invention is preferably smooth and rounded to minimize suture abrasion, while the distal portion of the anchor is tapered to an elongated point to enable the anchor to be self-tapping. The proximal end portion of the suture anchor body has a hexagonally shaped opening to accept a hexagonal drive head.

[0015] The internal transverse pin provides a support over which one or more strands of suture can be looped, such that the suture is secured in a recessed fashion within the anchor.

[0016] Advantageously, suture attached to the anchor through the transverse pin exits the suture anchor through a central bore in the anchor, which prevents suture abrasion by the wall of the bone tunnel into which the anchor is inserted.

[0017] Other features and advantages of the present invention will become apparent from the following description of the invention, which refers to the accompanying drawings.

BRIEF DESCRIPTION OF THE DRAWINGS

[0018] FIG. 1 is a side elevational view of the suture anchor of the present invention.

[0019] FIG. 2 is a longitudinal sectional view of the suture anchor shown in FIG. 1 through the plane D-D indicated therein.

[0020] FIG. 3 is a proximal end view of the suture anchor of FIG. 1.

[0021] FIG. 4 is a cross sectional view of the suture anchor of FIG. 1 showing a suture looped over the transverse anchor pin.

DETAILED DESCRIPTION OF THE PREFERRED EMBODIMENTS

[0022] In the following detailed description, reference is made to various specific embodiments in which the invention may be practiced. These embodiments are described with sufficient detail to enable those skilled in the art to practice the invention, and it is to be understood that other embodiments

may be employed, and that structural and logical changes may be made without departing from the spirit or scope of the present invention.

[0023] FIG. 1 illustrates a suture anchor according to a first preferred embodiment of the present invention, indicated generally by reference numeral 110. In the preferred embodiment, body 108 of anchor 110 generally tapers to a narrow point 114 at the distal end thereof. In particular, the major diameter of the anchor body is generally constant along about two-thirds of the length of the body, whereupon the diameter of the anchor then tapers to a relatively sharp point, e.g., approximately 16.degree. The relatively sharp distal tip of anchor 110 enables the anchor to be installed without having to first drill a hole in the bone where the anchor 110 is to be installed.

[0024] Although such tapering is preferred, suture anchor 110 may be formed to have a less tapered shape, or even cylindrical shape, to accommodate different preferences of the surgeon and/or the application of the suture anchor. For example, the tapered distal end of the anchor may be formed to be more blunt, in which case it is necessary to provide a pre-formed hole in the bone prior to insertion of the suture anchor.

[0025] A continuous thread 116 wraps around the body 108 in a clockwise direction, as shown. Anchor 110 has about five flights of thread, with the angle of the threads and other configurations of the anchor being similar to the suture anchor of U.S. Pat. No. 6,511,499, the disclosure of which is hereby incorporated by reference in its entirety.

[0026] As can be seen more clearly with reference to FIG. 2, the proximal end portion of the anchor has a hexagonally shaped bore 132 having an opening 122 at the proximal end of anchor body 108 and extending into the anchor body approximately one-third of the length thereof. Prior art anchors have sharp edges around the drive opening, which is problematic in that sutures passing through the central opening at the proximal end of the anchor can be abraded by the sharp edges, thereby compromising the strength of the sutures. In the suture anchor of the present invention, the peripheral edges defining hexagonally shaped opening 122 is smooth and rounded outwardly with no sharp edges. Preferably, the opening 122 forms a slight lip curving around the diameter of the bore 132. Thus, sutures threaded through the anchor 110, as will be discussed below, will not become frayed upon being pressed or rubbed against the anchor at the proximal opening 122.

[0027] A cylindrical bore 136 having a diameter corresponding to that of the hexagonally shaped bore 132 extends from the distal end of the hexagonally shaped bore 132 to a position roughly halfway along the length of anchor body 108. The transition between hexagonally shaped bore 132 and cylindrical bore 136 forms an annular shoulder 134, against which the distal end of a hex driver abuts when inserted into the hexagonally shaped bore 132 to drive the anchor into bone.

[0028] Two longitudinal, diametrically opposite apertures 118 are formed in anchor body 108, the apertures 118 supporting a metal transverse anchor pin 120 which extends across cylindrical bore 136.

[0029] As can be seen in FIGS. 1, 2 and 4, apertures 118 extend through and interrupt the threads 116 around anchor body 108 at approximately one-third of the length of the anchor body from the distal end thereof. One or more sutures 200 are secured to the anchor by looping the suture(s) around

metal anchor pin 120 as shown in FIG. 4. Although the metal anchor pin 120 is illustrated in FIGS. 2 and 4 as oriented transversal to longitudinal axis 150 of the anchor body 108, the metal anchor pin 120 may form any angle with the longitudinal axis 150 and, thus, the invention is not limited to metal anchor pin 120 forming an angle of about ninety degrees with the longitudinal axis 150 of the anchor body 108.

[0030] Preferably, suture anchor 110 is formed of a hard biocompatible metal, such as a titanium alloy, but can be made of biocompatible materials other than metal. The suture secured to the anchor may be FiberWire suture, sold by Arthrex, Inc. of Naples, Fla.

[0031] The suture anchor according to the present invention need not be formed as a threaded device, but can also be formed as a tap-in type anchor. Also, the measurements, angles and ratios between the dimensions of the suture anchor may be varied from those described above so as to be suitable for the conditions and applications in which the suture anchor is to be used.

[0032] In manufacturing the suture anchor 110 in accordance with the present invention, the anchor body 108 is cast in a die, with the bores, passageways and apertures described above either being formed during the casting process or formed afterwards. If necessary, the distal tip 114 of the anchor 110 is trimmed to the desired length and the surfaces of the anchor are polished to the desired finish.

[0033] As mentioned above, the suture anchor of the present invention may be installed in the bone without the need to pre-drill a hole in the bone. The suture anchor is installed using a driver having a shaft having a hexagonal cross-section for at least a length equal to the length of the hexagonal bore 132 from proximal opening 122 to the shoulder 134 inside the anchor 110. The driver has a cannula extending through the entire length thereof, with openings at the proximal and distal ends thereof. Of course, the outer diameter of the hexagonal shaft is sized to fit inside the hexagonal bore in the anchor so as to be enabled to drive the same.

[0034] With the desired number of suture strands threaded through the suture loop in the suture anchor, the ends of the suture strands are threaded through the cannula in the hex driver from the distal end thereof and exiting from the proximal opening thereof. The distal end of the hexagonal shaft of the driver is then inserted into the proximal end of the anchor while the suture loop is inserted into the distal end opening of the driver. With the distal end of the driver abutting shoulder 134 and the anchor positioned at the location at which it is to be installed, the hex driver is rotated to drive the anchor into the bone until the proximal surface of the anchor is flush with the surface of the bone.

[0035] Since it is not necessary for the proximal end of the anchor to be countersunk below the bone surface to prevent tissue abrasion by an exposed suture loop, as is required with prior art devices, the suture anchor of the present invention does not need to be inserted as far as the prior art anchors, while also avoiding abrasion of the sutures by the rim of the bone.

[0036] The suture anchor of the present invention provides greater pull-out strength of the suture loop than prior suture anchors. In addition, the suture loop of the present invention, being disposed inside the suture anchor, is protected from abrasion and degradation.

[0037] Although the present invention has been described in relation to particular embodiments thereof, many other

variations and modifications and other uses will become apparent to those skilled in the art. Therefore, the present invention is to be limited not by the specific disclosure herein, but only by the appended claims.

What is claimed is:

- 1. A suture anchor comprising:
an anchor body having a central bore extending from an opening at an end of the anchor body and through a portion of a length thereof, wherein the central bore has a cross-sectional shape to accommodate a driver head for driving the suture anchor; and
a pin disposed in the central bore transversely relative to a longitudinal axis of the anchor body, wherein at least one suture strand is looped around the pin.
- 2. The suture anchor as recited in claim 1, wherein the central bore includes a first section and a second section, the first section accommodates the driver head, and the pin is disposed in the second section.
- 3. The suture anchor as recited in claim 2, wherein the first section and the second have different cross-sectional shapes.
- 4. The suture anchor as recited in claim 2, wherein the first section has a hexagonally shaped cross section and the second section is substantially cylindrical.
- 5. The suture anchor as recited in claim 1, wherein the anchor body includes a thread extending from an outer surface of the anchor body.
- 6. The suture anchor as recited in claim 5, wherein the central bore includes a first section and a second section, the first section accommodates the driver head, the pin is disposed in the second section, and the thread surrounds both the first section and the second section.
- 7. The suture anchor as recited in claim 2, wherein the at least one suture strand and the pin contact in the second section of the central bore.
- 8. The suture anchor as recited in claim 1, wherein the at least one suture strand includes two suture strands.
- 9. The suture anchor as recited in claim 1, wherein the pin has a length and the central bore has an inner diameter, and the length of the pin is greater than the inner diameter of the central bore.
- 10. The suture anchor as recited in claim 1, wherein the central bore includes two passages that each define an aperture in the anchor body, the pin includes two ends, and each end is disposed in one of the apertures.
- 11. The suture anchor as recited in claim 1, wherein the at least one suture is unknotted to the pin.
- 12. The suture anchor as recited in claim 1, wherein the anchor body is made of metal.
- 13. The suture anchor as recited in claim 1, wherein the pin is made of metal.
- 14. The suture anchor as recited in claim 1, wherein the anchor body is tapered.

15. The suture anchor as recited in claim 14, wherein the anchor body is tapered to a substantially narrow point.

16. The suture anchor as recited in claim 1, wherein the anchor body is self-tapping.

17. The suture anchor as recited in claim 1, wherein the pin is disposed substantially perpendicular to the longitudinal axis of the anchor body.

18. A suture anchor assembly for attachment of tissue to bone, the suture anchor assembly comprising:

- a suture anchor including an anchor body having a proximal end, a distal end, and a central bore extending from an opening at the proximal end of the anchor body and through a portion of a length thereof, wherein the central bore has a cross-sectional shape to accommodate a driver head for driving the suture anchor, the suture anchor also including a pin disposed in the central bore transversely relative to a longitudinal axis of the anchor body; and

at least one suture strand looped around the pin, wherein the at least one suture strand includes ends that extend through the central bore and out the proximal end of the anchor body.

19. The suture anchor assembly as recited in claim 18, wherein the central bore includes a first section and a second section, the first section accommodates the driver head, and the pin is disposed in the second section.

20. The suture anchor assembly as recited in claim 19, wherein the first section has a hexagonally shaped cross section and the second section is substantially cylindrical.

21. The suture anchor assembly as recited in claim 19, wherein the anchor body includes a thread extending from an outer surface of the anchor body, and the thread surrounds both the first section and the second section.

22. The suture anchor assembly as recited in claim 19, wherein the at least one suture strand and the pin contact in the second section of the central bore.

23. The suture anchor assembly as recited in claim 18, wherein the central bore includes two passages that each define an aperture in the anchor body, the pin includes two ends, and each end is disposed in one of the apertures.

24. The suture anchor assembly as recited in claim 18, wherein the at least one suture is unknotted to the pin.

25. A method of assembling a suture anchor, the method comprising the steps of:

- providing an anchor body having a central bore extending from an opening at an end of the anchor body and through a portion of a length thereof, wherein the central bore has a cross-sectional shape to accommodate a driver head for driving the suture anchor;
- disposing a pin in the central bore transversely relative to a longitudinal axis of the anchor body; and
- looping at least one suture strand around the pin.

* * * * *