



(51) International Patent Classification:
H01Q 1/27 (2006.01)

(21) International Application Number:
PCT/CN2023/098816

(22) International Filing Date:
07 June 2023 (07.06.2023)

(25) Filing Language: English

(26) Publication Language: English

(71) Applicant: **GOERTEK INC.** [CN/CN]; No. 268 Dongfang Road, Hi-Tech Industry District, Weifang, Shandong 261031 (CN).

(72) Inventor: **KODAMA, Kenichiro**; No. 268 Dongfang Road, Hi-Tech Industry District, Weifang, Shandong 261031 (CN).

(74) Agent: **GRANDER IP LAW FIRM**; Suite 18A6, East Wing, Hanwei Plaza, No.7 Guanghua Road, Chaoyang District, Beijing 100004 (CN).

(81) Designated States (unless otherwise indicated, for every kind of national protection available): AE, AG, AL, AM, AO, AT, AU, AZ, BA, BB, BG, BH, BN, BR, BW, BY, BZ, CA, CH, CL, CN, CO, CR, CU, CV, CZ, DE, DJ, DK, DM, DO, DZ, EC, EE, EG, ES, FI, GB, GD, GE, GH, GM, GT, HN, HR, HU, ID, IL, IN, IQ, IR, IS, IT, JM, JO, JP, KE, KG,

KH, KN, KP, KR, KW, KZ, LA, LC, LK, LR, LS, LU, LY, MA, MD, MG, MK, MN, MU, MW, MX, MY, MZ, NA, NG, NI, NO, NZ, OM, PA, PE, PG, PH, PL, PT, QA, RO, RS, RU, RW, SA, SC, SD, SE, SG, SK, SL, ST, SV, SY, TH, TJ, TM, TN, TR, TT, TZ, UA, UG, US, UZ, VC, VN, WS, ZA, ZM, ZW.

(84) Designated States (unless otherwise indicated, for every kind of regional protection available): ARIPO (BW, CV, GH, GM, KE, LR, LS, MW, MZ, NA, RW, SC, SD, SL, ST, SZ, TZ, UG, ZM, ZW), Eurasian (AM, AZ, BY, KG, KZ, RU, TJ, TM), European (AL, AT, BE, BG, CH, CY, CZ, DE, DK, EE, ES, FI, FR, GB, GR, HR, HU, IE, IS, IT, LT, LU, LV, MC, ME, MK, MT, NL, NO, PL, PT, RO, RS, SE, SI, SK, SM, TR), OAPI (BF, BJ, CF, CG, CI, CM, GA, GN, GQ, GW, KM, ML, MR, NE, SN, TD, TG).

Published:
— with international search report (Art. 21(3))

(54) Title: HEAD-MOUNTED DEVICE, ANTENNA AND USER EQUIPMENT

[Fig. 6]

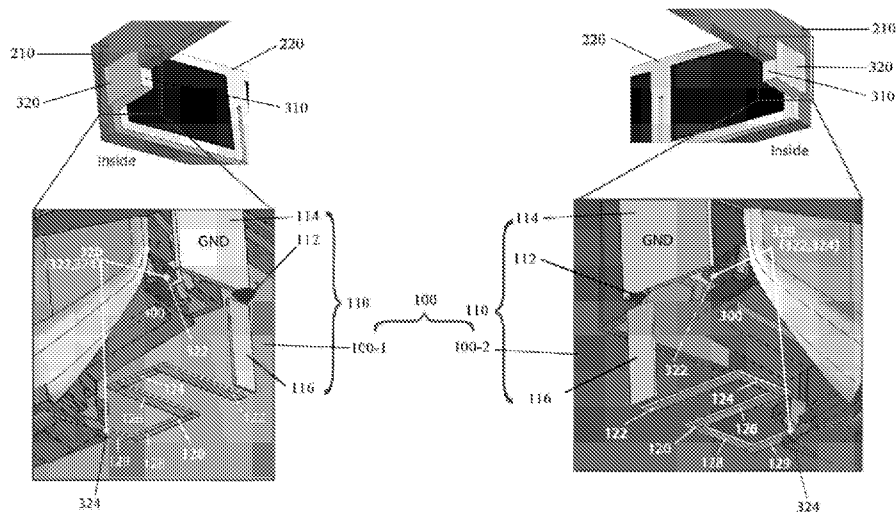

(57) Abstract: Head-mounted devices, antennas (100) and user equipment (10), may include an antenna(100) disposed proximate to a module(300) of a head-mounted device including non-electrically conductive material.

WO 2024/250193 A1

Description

Title of Invention: HEAD-MOUNTED DEVICE, ANTENNA AND USER EQUIPMENT

TECHNICAL FIELD

[0001] Various embodiments herein generally pertains to the field of wireless communications, and more specifically, to a head-mounted device, an antenna and a user equipment.

BACKGROUND

[0002] Recent decades have witnessed prosperity of electronic wearable devices. Being designed properly, these devices are generally not handheld during usage, but are "worn" as accessories or even apparel on body parts of a user, i.e. a wearer. Hence, it is quite convenient for the wearer to interact with the outside world simultaneously in various manners. For example, the virtual reality (VR) , augmented reality (AR) , or extended reality (XR) technology may apply electronic headwear to provide visual and/or acoustic information, while the wearer is able to operate a keyboard or a gamepad by hand. For another example, an electronic wristband may collect electro-cardio signals of the wearer, while not interrupting daily activities of the wearer. For another example, electronic eyeglasses may prompt the wearer with detailed content of instant messages, even when both bands of the wearer are occupied. Since visual signals and acoustic signals are most common among all kinds of information received by human beings, many electronic wearable devices are head-mounted to facilitate interaction with the eyes, the ears, and the vocal organs of the wearers, or to provide a vivid imitation on wearers' real perception.

[0003] Rapid development of the batteries and the integrated circuits renders electronic wearable devices smaller sizes and more compact structures, which aims at merging them into each application scenario in people's daily life. Therefore, an increasing requirement on convenient "anytime and anywhere" accesses to the Internet and WLANs demands the electronic wearable devices wireless and portable. A prospect is that the electronic wearable devices are capable to provide high-quality wireless accesses while not causing an impact on an electromagnetic environment of other components in the device. For example, an AR/VR head-mounted display should be no larger and no heavier than ordinary eyeglasses or goggles. Such objective raises great challenges on a robust design of the electronic wearable devices, especially the head-mounted devices.

SUMMARY

- [0004] In some embodiments, the present disclosure may provide a head-mounted device, including: a housing including electrically conductive material; a module including a first portion including non-electrically conductive material and disposed on a portion of the housing distant from a head of a user when the head-mounted device is worn by the user; and an antenna disposed proximate to the module.
- [0005] In some other embodiments, the present disclosure may provide an antenna including: a first element comprising: a feedpoint, a first member disposed on a first side of the feedpoint and connected to a portion of a user equipment including electrically conductive material, and a second member disposed on a second side of the feedpoint; and a second element disposed to be spaced from the second member and connected to another portion of the user equipment including electrically conductive material.
- [0006] In some other embodiments, the present disclosure may provide a user equipment including: a first portion including non-electrically conductive material; a second portion including electrically conductive material; and an antenna disposed proximate to the first portion including: a first element including: a feedpoint, a first member disposed on a first side of the feedpoint and connected to a first position of the second portion and a second member disposed on a second side of the feedpoint; and a second element disposed to be spaced from the second member and connected to a second position of the second portion..

BRIEF DESCRIPTION OF THE DRAWINGS

- [0007] Features and advantages of the disclosure will be apparent from the detailed description which follows, taken in conjunction with the accompanying drawings, which together illustrate, by way of example, features of the disclosure; and, wherein:
- [0008] FIG. 1 illustrates a schematic structural diagram of user equipment (UE) when being worn by a user in accordance with some embodiments;
- [0009] FIGS. 2 to 4 illustrate examples of an arrangement of the antenna in the UE;
- [0010] FIG. 5 illustrates another example of an arrangement of the antenna in the UE;
- [0011] FIG. 6 illustrates a schematic diagram of the antenna in accordance with some embodiments;
- [0012] FIG. 7 illustrates a dimension example of the antennas as shown in FIG. 6;
- [0013] FIGS. 8 and 9 illustrate results of simulation of current distribution of the antennas as shown in FIG. 7;
- [0014] FIG. 10 illustrates a result of simulation of impedances of the antennas as shown in FIG. 7;
- [0015] FIG. 11 illustrates a result of simulation of efficiencies of the antennas as shown in FIG. 7; and

- [0016] FIGS. 12 and 13 illustrates results of simulation of radiation patterns of the antennas as shown in FIG. 7.
- [0017] DETAILED DESCRIPTION OF THE EMBODIMENTS
- [0018] The following detailed description refers to the accompanying drawings. The same reference numbers may be used in different drawings to identify the same or similar elements. In the following description, for purposes of explanation and not limitation, specific details are set forth such as particular structures, architectures, interfaces, techniques, etc., in order to provide a thorough understanding of the various aspects of the claimed embodiments. However, it will be apparent to those skilled in the art having the benefit of the present disclosure that the various aspects of the embodiments claimed may be practiced in other examples that depart from these specific details. In certain instances, descriptions of well-known devices, circuits, and methods are omitted so as not to obscure the description of embodiments of the present disclosure with unnecessary detail.
- [0019] Various aspects of the illustrative embodiments will be described using terms commonly employed by those skilled in the art to convey the substance of their work to others skilled in the art. However, it will be apparent to those skilled in the art that alternate embodiments may be practiced with only some of the described aspects. For purposes of explanation, specific numbers, materials, and configurations are set forth in order to provide a thorough understanding of the illustrative embodiments. However, it will be apparent to one skilled in the art that alternate embodiments may be practiced without the specific details. In other instances, well-known features are omitted or simplified in order not to obscure the illustrative embodiments.
- [0020] The phrase “in various embodiments,” “in some embodiments,” and the like are used repeatedly. The phrase generally does not refer to the same embodiments; however, it may. The terms “comprising,” “having,” and “including” are synonymous, unless the context dictates otherwise. The phrase “A or B” means (A) , (B) , or (A and B) .
- [0021] Hereinafter, various embodiments will be described briefly and with reference to FIGS. 1-13.
- [0022] In some embodiments, user equipment, such as, the wireless and portable electronic wearable devices, provides a compact design of components within the devices. Such a compact design may be required for a head-mounted device since a bulky and heavy head-mounted device would not only cause inconvenience during usage but also brings health risks, especially aggravating neck pains. Consequently, a lot of head-mounted devices try to dispose every component as close as possible to the user’s head, such that the users would experience less discomforts due to the imbalanced additional weight when moving or turning their heads. Such design also brings the antenna

quite close to a body of the user. For example, an antenna of electronic eyeglasses is disposed at a tip or an intermediate part of temple bar, which is close to an ear or a temple of the user. Since the human body creates an inductance of approximately 500nH to 750nH, it attenuates electromagnetic waves and results in reduced intensities and increased bit error rates of wireless signals that are transmitted or received by the antenna. Consequently, the wireless communication of the head-mounted device is degraded.

[0023] In some embodiments, in order to improve quality of wireless communications, the antenna may be disposed at a side of a head-mounted device, such as, a side of the lens of the head-mounted devices, distant from a head of a user when the head-mounted device is worn by the user. However, the user may prefer electrically conductive material, such as metal, as an outer part, such as, metal frame, of the head-mounted device due to its sense of luxuriousness. In this case, the area where the antenna is disposed is expected to be changed into non-electrically conductive material, such as plastic, since performance of the antenna is dropped under electrically conductive material condition, which deteriorates the sense of luxuriousness and increase the complexity of the industrial design. Thus, in some embodiments, there may be a demand for maintaining the performance of the antenna as well as the a sense of luxuriousness without changing the design of the outer part, such as metal frame.

[0024] To this end, in some embodiments, a head-mounted device is provided, including: a housing including electrically conductive material; a module including a first portion including non-electrically conductive material and disposed on a portion of the housing distant from a head of a user when the head-mounted device is worn by the user; and an antenna disposed proximate to the module.

[0025] In some embodiments, the antenna may be disposed proximate to the first portion.

[0026] In some embodiments, the module may further include a second portion including electrically conductive material and the antenna is connected to the second portion.

[0027] In some embodiments, the antenna may include: a first element including a feedpoint, a first member disposed on a first side of the feedpoint and connected to the second portion, and a second member disposed on a second side of the feedpoint; and a second element disposed to be spaced from the second member and connected to the second portion.

[0028] In some embodiments, the second member may be configured to be fed and the second element is configured to be grounded.

[0029] In some embodiments, the second element may be spaced from the second member on a side of the second member distant from the feedpoint.

[0030] In some embodiments, the first member and the second element may be connected to respective distal positions of the second portion.

- [0031] In some embodiments, an edge of the second element and an edge of the second member may turn to each other.
- [0032] In some embodiments, the second member may have a length shorter than that of the second element.
- [0033] In some embodiments, the first element may be configured to operate in a first frequency and the second element is configured to operate in the first frequency and a second frequency.
- [0034] In some embodiments, the first frequency may be higher than the second frequency.
- [0035] In some embodiments, the module may be selected from at least any one of a group consisting of an optical module and an camera module.
- [0036] In some embodiments, the electrically conductive material may include metal.
- [0037] In some embodiments, the non-electrically conductive material may include plastic.
- [0038] In some embodiments, an antenna may be provided, including: a first element including a feedpoint, a first member disposed on a first side of the feedpoint and connected to a portion of a user equipment including electrically conductive material, and a second member disposed on a second side of the feedpoint; and a second element disposed to be spaced from the second member and connected to another portion of the user equipment including electrically conductive material.
- [0039] In some embodiments, the portion and the another portion of the user equipment may be the respective distal positions of the second portion of the head-mounted device.
- [0040] In some embodiments, the portion and the another portion may be distant from each other.
- [0041] In some embodiments, a user equipment may be provided, including: a first portion including non-electrically conductive material; a second portion including electrically conductive material; and an antenna disposed proximate to the first portion, the antenna including: a first element including: a feedpoint, a first member disposed on a first side of the feedpoint and connected to a first position of the second portion and a second member disposed on a second side of the feedpoint; and a second element disposed to be spaced from the second member and connected to a second position of the second portion.
- [0042] In some embodiments, the first portion of the user equipment may be the first portion of the module of the head-mounted device and the second portion of the user equipment may be the second portion of the module of the head-mounted device.
- [0043] In some embodiments, the first and second positions may be the distal positions, including electrically conductive material, of the module of the head-mounted device.
- [0044] In some embodiments, the first position and the second position are distant from each other.

[0045] In some embodiments, the antenna may be configured to transmit or receive wireless signals and is located at a portion of the housing of the head-mounted devices. In this case, the portion protrudes away from a head of a user when the head-mounted device is worn by the user. Since the antenna is disposed distant from a head of the user, a large portion of the wireless signals propagates through free space without being influenced by the human body. Hence, the wireless signals are less attenuated and quality of wireless communications is improved during usage of the head-mounted devices.

[0046] FIG. 1 illustrates schematic structural diagrams of user equipment (UE) when being worn by a user in accordance with some embodiments. In FIG. 1, UE 10 is shown to be a head-mounted device. The UE 10 includes an antenna 100, a housing 200 and a module 300.

[0047] The antenna 100 is configured for various kinds of communications.

[0048] In some embodiments, the antenna 100 may be configured for cellular communications, in accordance with e.g., Global System for Mobile Communication (GSM), General Packet Radio Service (GPRS), Universal Mobile Telecommunications System (UMTS), High Speed Packet Access (HSPA), Evolved HSPA (E-HSPA), Long-Term Evolution (LTE), LTE-Advanced (LTE-A), Enhanced Mobile Broadband (eMBB), Ultra Reliable Low Latency Communications (URLLC), and/or Massive Machine Type Communications (mMTC). The antenna 100 may also be configured for cellular communications in accordance with Enhanced Data for GSM Evolution (EDGE), GSM EDGE Radio Access Network (GERAN), Universal Terrestrial Radio Access Network (UTRAN), or Evolved UTRAN (E-UTRAN). The antenna 100 may be configured for cellular communications in accordance with Code Division Multiple Access (CDMA), Time Division Multiple Access (TDMA), Digital Enhanced Cordless Telecommunications (DECT), Evolution-Data Optimized (EV-DO), derivatives thereof, as well as any other wireless protocols that are designed as 3G, 4G, 5G, 6G and beyond.

[0049] In some embodiments of cellular communications, before transmitted or after received as electromagnetic waves, the wireless signals may be in a form of an oscillating current or an oscillating voltage at, for example, a radio-frequency (RF) connector for the antenna 100. The RF connector is configured to connect the antenna electrically with RF circuitry, so that the RF circuitry provides a feed to the antenna. In practice, the RF connector may be implemented by on-board wires, an independent cable, or the like.

[0050] In some embodiments, the RF circuitry may be coupled with or may be a part of processing circuitry, and is configured to convert the oscillating current or the oscillating voltage into a signal compatible with a processing capability of the

processing circuitry, or the vice versa. Generally, the conversion is implemented through modulation or demodulation. Specifically, the RF circuitry modulates the oscillating current or the oscillating voltage based on a signal generated by the processing circuitry, and then the antenna converts the modulated oscillating current or the oscillating voltage into the wireless signals for transmission. Similarly, the antenna converts the received wireless signals into the oscillating current or the oscillating voltage, and the RF circuitry demodulates the oscillating current or the oscillating voltage to acquire a signal for processing at the processing circuitry. In this embodiment, the processing at the processing circuitry may include, but is not limited to, coding or decoding of visual signals, acoustic signals, or control signals. In practice, the processing circuitry may be implemented in various manners. For example, the processing circuitry may be an application specific integrated circuit (ASIC), a field-programmable gate array (FPGA), a special-purpose chip, or the like. For another example, the processing circuitry is an independent chip mounted on a printed circuit board (PCB), or may be integrated into another chip having multiple functions. The present disclosure is not limited to the above example, and any appropriate chip may serve as the processing circuitry as long as it is capable to process the wireless signals.

[0051] The RF circuitry and the processing circuitry are not depicted in FIG. 1. Each of the RF circuitry and the processing circuitry may or may not be a component included in the head-mounted device. That is, the UE may have a capability of signal processing, or may serve as a plug-in unit of another device capable of signal processing, which is not limited herein.

[0052] In some embodiments, the antenna 100 may be configured for Wi-Fi communications, though the scope of the embodiments is not limited in this respect. In some of these embodiments, the antenna 100 may be configured to receive and transmit orthogonal frequency division multiplexed (OFDM) or orthogonal frequency division multiple access (OFDMA) communication signals over a multicarrier communication channel. The OFDM or OFDMA signals may include a plurality of orthogonal subcarriers. In some of these multicarrier embodiments, the antenna 100 may be configured to transmit or receive signals in accordance with specific communication standards and/or protocols, such as any of the Institute of Electrical and Electronics Engineers (IEEE) standards including, IEEE 802.11n-2009, IEEE 802.11-2012, IEEE 802.11-2016, IEEE 802.11ac, and/or IEEE 802.11ax standards and/or proposed specifications for WLANs, though the scope of aspects is not limited in this respect. The antenna 100 may also be configured to transmit and/or receive communications in accordance with other techniques and standards. In some embodiments, the antenna 100 may be configured for high-efficiency Wi-Fi communications in accordance with

Rule 91,
17.07.2023

the IEEE 802.11ax standard. In these embodiments, the antenna 100 may be configured to communicate in accordance with an OFDMA technique, though the scope of the embodiments is not limited in this respect.

- [0053] In some other embodiments, the antenna 100 may be configured to transmit and receive signals transmitted using one or more other modulation techniques, such as, spread spectrum modulation, e.g., direct sequence code division multiple access (DS-SS) and/or frequency hopping code division multiple access (FH-SS), time-division multiplexing (TDM) modulation, and/or frequency-division multiplexing (FDM) modulation, although the scope of the embodiments is not limited in this respect.
- [0054] In some embodiments, the antenna 100 may be configured for Bluetooth® (BT) communications and be compliant with a BT connectivity standard such as Bluetooth, Bluetooth 4.0 or Bluetooth 5.0, or any other iteration of the Bluetooth Standard. In these embodiments, the antenna 100 may be configured to establish a BT synchronous connection oriented (SCO) link and/or a BT low energy (BT LE) link. In some of the embodiments, the antenna 100 may be configured to establish an extended SCO (eSCO) link for BT communications. In some of these embodiments, the antenna 100 may be configured to engage in a BT Asynchronous Connection-Less (ACL) communications.
- [0055] In some embodiments, the antenna 100 may be configured for communication over various channel bandwidths including bandwidth having center frequencies of about 900MHz, 2.4GHz, 5GHz and bandwidths of about 1MHz, 2MHz, 2.5MHz, 4MHz, 5MHz, 8MHz, 10MHz, 16MHz, 20MHz, 40MHz, 80MHz with contiguous bandwidths or 80+8QMHz (160MHz) with non-contiguous bandwidths, though the scope of the embodiments is not limited in these respects. In an example that the antenna 100 is compliant with Wi-Fi standard, the frequency band of the antenna may range from 2.4GHz to 2.48GHz, or from 5.15GHz to 7.15GHz. In another example that the antenna 100 is compliant with Bluetooth®, the frequency band may range from 2.4GHz to 2.485GHz.
- [0056] In some embodiments, the antenna 100 may be configured as various types, including a monopolar antenna, a slot antenna, a loop antenna, an inverted-L antenna, an inverted-F antenna, a meander antenna and the like, though the scope of the embodiments is not limited in this respect.
- [0057] The housing 200 may be configured to protect component (s) accommodating therein. Although the housing 200 in FIG. 1 is depicted as a hollow polygon for simplicity of illustration, the housing 200 may have various designs in different application scenarios in practice, and may have another or other part (s) other than what is depicted in the drawings. In some embodiments, at least a surface of the housing 200

may be curved, bended, or twisted. In some examples, at least a portion of the housing 200 may be solid or filled with materials and/or components. In some examples, the housing 200 may further include a part located near an un-depicted part of the head 20. Various components may be disposed in the housing 200 based on an overall design or overall architecture, and hence each of the components occupies a corresponding space in the housing 200. Components other than the antenna 100 and module 300 are not depicted in FIG. 1 for simplicity of illustration.

[0058] The housing 200 may include or made of electrically conductive material. In some embodiments, electrically conductive material may include metal. In some embodiments, the metal may include aluminum, magnesium, iron, titan and the like. In other embodiments, the metal may include alloys, such as, stainless steel, magnesium-aluminum alloy and the like. The scope of these embodiments are not limited in these respects. In some embodiments, the housing 200 may include metal frame. In these embodiments, the housing 200 may achieve a sense of luxuriousness for the UE 10.

[0059] In some embodiments, the housing 200 may further include non-electrically conductive material. In some embodiments, non-electrically conductive material may include plastic, ceramic, glass, rubber and the like. In some embodiments of using plastic, the plastic may include acrylic or polymethyl methacrylate (PMMA), polycarbonate (PC), polyethylene (PE), polypropylene (PP), polyethylene terephthalate (PETE), polyvinyl chloride (PVC), Acylonitrile-Butadiene-Styrene (ABS) and the like. The scope of these embodiments are not limited in these respects.

[0060] In some embodiments, the housing 200 may include an apparent portion which is relatively clearly visible by another person other than the user when the UE 10 is worn by the user and a hidden portion which is not relatively clearly visible by another person other than the user when the UE 10 is worn by the user. In some embodiments, the apparent portion may include electrically conductive material which may achieve a sense of luxuriousness for the UE 10 and the hidden portion may include non-electrically conductive material. In some embodiments that the housing 200 include a front cover and a rear cover, the apparent portion may be the front cover of the housing 200 and the hidden portion may be the rear cover of the housing 200.

[0061] The module 300 is configured to achieve functionality of UE 10. The module 300 may be implemented in various forms. In some embodiments, the module may include optical module or camera module. In some embodiments, the module 300 may include a projector configured to project an image to the UE 10. In some embodiments, the module 300 may include a camera, a sensor, a speaker, a connecting interface, a battery, and/or the like, which is not specifically limited herein. In some embodiments, the sensor may include an inertial measurement unit (IMU) including an accelerometer, a gyroscope and a magnetometer, a time-of-flight sensor, a thermal map sensor, a

structured light sensor, a depth sensing sensor, a forward facing tracking and recording camera, an eye-tracking camera, a directional microphone, an ambient light sensor, bio sensors, a bone-connection directional audio transducer, an infrared (IR) sensor and/or the like, which is not specifically limited herein. In some embodiments that the module 300 includes optical module, the optical module may include a thermal map sensor, a structured light sensor, a depth sensing sensor, an ambient light sensor, an IR sensor and the like. In some embodiments that the module 300 includes a camera module, the camera module may include forward facing tracking and recording cameras, eye-tracking cameras, rear cameras and/or the like, which is not specifically limited herein.

[0062] The module 300 may include a first portion 310 including non-electrically conductive material. In some embodiments, the first portion 310 may be or include a rear cover of the module 300, though the scope of the embodiments is not limited in this respect.

[0063] In some embodiments, non-electrically conductive material may include plastic, ceramic, glass, rubber and the like. In some embodiments of using plastic, the plastic may include acrylic or polymethyl methacrylate (PMMA), polycarbonate (PC), polyethylene (PE), polypropylene (PP), polyethylene terephthalate (PETE), polyvinyl chloride (PVC), Acrylonitrile-Butadiene-Styrene (ABS) and the like. The scope of these embodiments are not limited in these respects.

[0064] In some embodiments, the module 300 may further include a second portion 320 including electrically conductive material. The second portion 320 may be or include a mount of the module 300, though the scope of the embodiments is not limited in this respect. In some embodiments, electrically conductive material may include metal. In some embodiments, the metal may include aluminum, magnesium, iron, titan and the like. In other embodiments, the metal may include alloys, such as, stainless steel, magnesium-aluminum alloy and the like. The scope of these embodiments are not limited in these respects. In some embodiments, the antenna 100 may be connected to the second portion 320.

[0065] In some embodiments, the module 300 may include an apparent portion which is relatively clearly visible by another person other than the user when the UE 10 is worn by the user and a hidden portion which is not relatively clearly visible by another person other than the user when the UE 10 is worn by the user. In some embodiments, the apparent portion may include electrically conductive material which may achieve a sense of luxuriousness for the UE 10 and the hidden portion may include non-electrically conductive material. In some embodiments that the module 300 include a front cover and a rear cover, the apparent portion may be the front cover of the module 300 and the hidden portion may be the rear cover of the module 300.

[0066] The module 300 may be disposed on a portion of the housing 200 distant from a head of a user when the head-mounted device is worn by the user and the antenna 100

may be disposed proximate to the module 300. In this case, the portion may protrude away from a head of a user when the UE 10 is worn by the user. Since the antenna 100 is disposed distant from a head of the user, a large portion of the wireless signals propagates through free space without being influenced by the human body. Hence, the wireless signals are less attenuated and quality of wireless communications is improved during usage of the UE 10. Further, since the antenna 100 may be disposed proximate to the module 300 which includes non-electrically conductive material, wireless signals are less attenuated and quality of wireless communications is improved during usage of the UE 10. Therefore, the performance of the antenna are maintained without loss of the sense of luxuriousness. Further, there is no need to change the existing design of the outer part of the housing 200, such as metal frame.

[0067] In some embodiments, the antenna 100 may be disposed proximate to the first portion of the module 300 including the non-electrically conductive material. Thus, wireless signals transmitted or received by the antenna 100 may be less attenuated and quality of wireless communications may be further improved during usage of the UE 10.

[0068] In some embodiments, the antenna 100 may be disposed proximate to the hidden portion of the housing 200 or the module 300 including the non-electrically conductive material. Thus, wireless signals transmitted or received by the antenna 100 may be less attenuated and quality of wireless communications may be further improved during usage of the UE 10.

[0069] The module 300 may be integral, intrinsic or internal to the UE 10, or may be external to the UE and may be detachably connected to the UE 10.

[0070] In some embodiments, the module 300 or the antenna 100 occupies a space in the housing 200. The module 300 or the antenna 100 may be located at a portion A of the housing 200, and the portion A may protrude away from a user, such as, his head 20, when the UE 10 is worn by the user. In some embodiments, methods of the user wearing the UE 10 depend on types of the UE 10. Generally, the user wearing the UE 10, e.g. wearing the head-mounted device, means that at least a part of the housing 200 contacts the at least a part of the user, such as, his head, so that the housing 200 is fixed or substantially fixed on a portion of his body, such as, on his head or near his head. In an example, the UE 10 are eyeglasses, and the housing 200 contacts users' ears through temple bars and contacts the user's nose through nose pads. In another example, the UE 10 is a helmet, and the housing 200 at least contacts the top of the head. In another example, the UE 10 is a head-mounted camera, and the housing 200 contacts the forehead, parietal ridge, or the crown of the head. In some embodiments, wearing methods can be determined solely as long as the type of the UE 10 is known. In some other embodiments, there are two or more methods. In such embodiments, the wearing method refers to a method in which normal operation of the worn UE 10

adopts the module 300 or the antenna 100 to implement the functionality of the module 300 or wireless communications. The part of the housing 200 which contacts the body, such as, head 20, is not depicted in FIG. 1 for clear illustration.

[0071] As shown in FIG. 1, a contour of the head of the user is indicated by a dashed curve, the portions are indicated by dotted circles, and the antenna 100 and the module 300 are indicated by black blocks located in the dotted circles. In some embodiments, there are multiple protrusions that points away from the head 20 in the housing 200, and the portion A may refer to any of these protrusions. As an example, the housing 200 in FIG. 1 may have at least two qualified protrusions, and hence there may be two candidate portions (which are denoted as portions A and A', respectively). Correspondingly, although only the portion A is depicted with the black block in FIG. 1, the module 300 or the antenna 100 may be disposed in either of the two candidate portions A. In some embodiments, the module 300 or the antenna 100 may be disposed in a candidate region having a larger distance to a skin of the user, that is, a candidate region which is farther from the head 20 of the user. In some embodiments, the candidate portion A may have a larger distance to the head 20 than the candidate portion A', and is thus more preferable than the portion A' for accommodating module 300 or the antenna 100. In some embodiments as shown in FIG. 1, the candidate portions A and A' have identical distances to the head 20, and there may thus be no preference between the two portions. In some embodiments, a candidate region having a largest distance to the head 20 among all candidate regions may be selected as the installation position of the module 300 or the antenna 100. That is, when the UE 10 is worn by a user, the portion A at which the module 300 or the antenna 100 is located is farthest from a part of the user, such as, his head among all portions which protrude away from the part, such as his head, in the housing.

[0072] Furthermore, the module 300 or the antenna 100 disposed at the portion A may refer to the module 300 or the antenna 100 located in a cavity in the housing 200 at the portion A, attached on a surface of the housing 200 at the portion A, embedded in the housing 200 at the portion A, or inlaid on the housing 200 at the portion A. That is, the module may or may not be exposed at the housing 200. An appropriate configuration may be selected based on an application scenario of the UE 10.

[0073] The schematic diagram in FIG. 1 is a view of the UE 10 along a certain direction, and such direction is not limited herein. That is, the direction may be forward, backward, upward, downward, leftward, rightward, or any other possible directions. Furthermore, it is noted that the black blocks in FIG. 1 is used only for simplicity of illustration, and does not indicate that a shape of the antenna 100 or module 300 is limited to a rectangle when viewed from the direction.

[0074] FIGS. 2 to 4 illustrate examples of an arrangement of the antenna 100 in the UE 10. In examples of FIGS. 2 to 4, the antenna 100 may be disposed at a side of the UE 10, such as, a side of the lens of the head-mounted devices, distant from a portion of a user, such as his head, when the UE is worn by the user, so that the loss of wireless signals due to human may be decreased. Further, as shown in FIG. 2 the housing 200 may be made of non-electrically conductive material, such as plastic, so that loss of wireless signals may be reduced as compared to the housing made of electrically conductive material, such as metal. However, the housing 300 may be expected to include or be made of electrically conductive material, such as metal, as an outer part, such as, metal frame, of the UE due to its sense of luxuriousness, as shown in the left portion of the FIG. 3. In this case, the front area where the antenna is disposed is expected to be partially, as shown in the right portion of FIG. 3, or wholly, as shown in FIG. 4, changed into non-electrically conductive material, such as plastic, since performance of the antenna is dropped under electrically conductive material condition. This deteriorates the sense of luxuriousness and increase the complexity of the industrial design.

[0075] FIG. 5 illustrate another example of an arrangement of the antenna 100 in the UE 10. In Fig. 5, the housing 200 may include an apparent portion 210, such as front cover, which is relatively clearly visible by another person other than the user when being worn and a hidden portion 220, such as rear cover, which is not relatively clearly visible by another person. The module 300 may include an apparent portion 320, such as front cover, which is relatively clearly visible by another person other than the user when being worn and a hidden portion 310, such as rear cover, which is not relatively clearly visible by another person. In some embodiments, the module 300 may include an optical module and/or a camera module. In some embodiments that the UE 10 is a head-mounted device, such as VR headset, AR headset or XR headset, the head-mounted device may include lens 400 disposed between the front cover and the rear cover of the housing 200 and the module 300 may be disposed on at least one side of the lens. In this case, the antenna 100 may be disposed proximate to the module 300. In some embodiments, the antenna 100 may be provided in plural, such as, two. In some embodiments, the module 300 may be provided in plural, such as two. In some embodiments, the number of antennas 100 may be equal to that of the modules 300, e.g. both in two, as shown in FIG. 5. In these embodiments, the antennas 100 may be disposed proximate to the respective modules 300. As shown in FIG. 5, in the embodiments that the antenna 100 and the module 300 are both provided in two, the modules 300 may be disposed on either side of the lens 400 and the antennas 100 may be disposed proximate to the respective modules 300. In some other embodiments, the number of antennas 100 may not be equal to, and may be higher or less than, that of the

module 300. In the embodiments that the number of antennas 100 is less than that of the modules 300, the antennas 100 may be disposed proximate to a part of the modules 300. In the embodiments that the number of antennas 100 is higher than that of modules 300, each of the antennas 100 may be disposed proximate to the corresponding module 300. In some embodiments, the antenna 100 may be disposed proximate to the hidden portion 220 or 320. Although the antenna 100 and the module 300 are both provided in two in FIG. 5, both of them may be provided in one. The scope of the embodiments is not limited in these respects.

[0076] FIG. 6 illustrates a schematic diagram of the antenna 100 in accordance with some embodiments. In FIG. 6, the antenna 100 includes a first antenna 100-1 disposed proximate to the module 300 disposed on a first side, e.g., left side, of the UE 10 and a second antenna 100-2 disposed proximate to the module 300 disposed on a second side, e.g., right side, of the UE 10. Although the antenna 100 is shown to be provided in two in FIG. 6, it is shown by way of illustration only, not limitation, and the number may be 3 or more or may be 1. As shown in FIG. 6, in some embodiments, the antenna 100 may include a first element 110 and a second element 120. The first element 110 may include a feedpoint 112, a first member 114 and a second member 116. The first member 114 may be disposed on a first side, such as upper side, of the feedpoint 112. The first member 114 may be connected to the second portion 320 of the module 300. The second member 116 may be disposed on a second side, such as lower side, of the feedpoint 112. The second element 120 may be disposed to be spaced from the second member 116 and connected to the second portion 320. In some embodiments, the second member 116 may be configured to be fed and the second element 120 may be configured to be grounded. In some embodiments, the first element 110 may operate as feeding element and the second element 120 may operate as a grounding element or a parasitic element. In some embodiments, the first member 114 may be a ground (GND) and the second member 116 may be a feeding member. In some embodiments, the second element 120 may be spaced from the second member 116 on a side of the second member 116 distant from the feedpoint 112. In some embodiments, the first member 114 and the second element 120 may be connected to respective distal positions 322 and 324 of the second portion 320. In some embodiments, the first member 114 may be connected to the upper position 322 of the second portion 320 including electrically conductive material and the second member 116 may be connected to the lower position 324 of the second portion 320. As such, the conductive portion of the module 300 may be used as a ground of the antenna 100, thereby reducing spatial occupation within the housing 200 and improving compactness of the UE 10.

- [0077] In some embodiments, an edge of the second element 126 and an edge of the second member 116 may turn to each other. Thus, a coupling effect of antenna 100 may be achieved. Due to the coupling, the antenna size can be reduced even though a metal frame is used. In some embodiments, the second element 120 may be bent. In some embodiments, the second element 120 may be formed in 'S' shape and may include a first part 122, a second part 124 substantially perpendicular to the first part 122, a third part 126 substantially parallel to the first part 122 and perpendicular to the second part 124, a fourth part 128 substantially parallel to the second part 124 and perpendicular to the third part 126 and a fifth part 129 substantially parallel to the first and third parts 122 and 126 and perpendicular to the fourth part 128. The first part 122 may be extended in a first direction, such as, X direction. The second part 124 may be extended from an end of the first part 122 which is distant from the second member 116 in a second direction, such as Y direction, perpendicular to the first direction. The third part 126 may be extended from an end of the second part 124 distant from the first part 122 in a direction opposite to the first direction. The fourth part 128 may be extended from an end of the third part 126 distant from the second part 124 in the second direction. The fifth part 129 may be extended from an end of the fourth part 128 distant from the third part in the first direction and connected to the second portion 320 of the module 300. In some embodiments, the second member 116 of the first element 110 may be formed in straight shape. The second member 116 may be extended in a third direction, such as Z direction, perpendicular to the first and second directions, with one end thereof connected to the feedpoint 112 and the other end thereof spaced from an end of first part 122 which is distant from the second part 124.
- [0078] In some embodiments, the second member 116 may have a length shorter than that of the second element 120. The shorter element may be configured for communications of higher frequency band and the longer element may be configured for communications of both higher and lower frequencies. In some embodiments, the first element 110 may be configured to operate in a first frequency and the second element 120 may be configured to operate in the first frequency and a second frequency. In some embodiments, the first frequency may be higher than the second frequency. In some embodiments, the first frequency may range from 2.4-2.48GHz and the second frequency may range from about 5-7GHz. The dimensions and shapes of components of the first element 110 and/or the second element 120 may be tuned to implement wireless communications in various frequency bands and may be changed according to the frequency band.
- [0079] In some embodiments, the first member 114, the second member 116 and/or the second element 120 may be conductive films, conductive sheets, or conductive lines, and may be implemented in various forms. In one embodiment, the first member 114,

the second member 116 and/or the second element 120 may be located on a portion of electrically conductive material of the housing. In an example, the first member 114, the second member 116 and/or the second element 120 may be located on a metal frame. In another embodiment, the first member 114, the second member 116 and/or the second element 120 may be located on a flexible printed circuit (FPC). For example, the first member 114, the second member 116 and/or the second element 120 may be metallic patterns printed on a flexible film. The flexible film may be directly or indirectly attached to the protruding portion A of the housing 200 and may be disposed proximate to the module 300, or may serve as an intermediate substrate for transferring the metallic patterns to the protruding portion A. In another embodiment, the first member 114, the second member 116 and/or the second element 120 may be located on may be integrated in a molded interconnected device (MID) of another technique. For example, the the first member 114, the second member 116 and/or the second element 120 may be metallic patterns formed on a doped thermoplastic material through a laser direct structuring (LDS) process, that is, located on a laser-direct-structured material. Moreover, these elements may be directly printed on the protruding portion A of the housing 200 through, for example, the LDS. In such case, at least a part of the protruding portion A may be a thermoplastic material or glass doped with metallic inorganic compound. It is appreciated that the MID may be implemented through other suitable techniques, which are not enumerated herein. When being the conductive film or the conductive sheet, the first member 114, the second member 116 and/or the second element 120 may be disposed in parallel with, in perpendicular to, or with an arbitrary angle to a surface of the housing 200. In some embodiments, at least a part of the first member 114, at least a part of the second member 116 and/or at least a part of the second element 120 may be directly printed on the housing 200.

[0080] Furthermore, in FIG. 6, the antenna 100 (antennas 100-1 and 100-2) is shown as monopolar antenna, such as $\lambda/4$ monopole type antenna, and however, the antenna 100 may be other types, such as, a slot antenna, a loop antenna, an inverted-L antenna, an inverted-F antenna, and a meander antenna.

[0081] Furthermore, as shown in FIG. 6, in some embodiments that the UE 10 is a head-mounted device (such as eyeglasses), the UE 10 may further include a lens 500 disposed in front of an eye of the user when the UE 10 is worn by the user, and the antenna 100 is located adjacent to the lens 500. Herein the antenna 100 located adjacent to the lens 500 may refer to the antenna structure 100 located directly adjacent to the lens 500, for example, attached to the lens 300 or abutting against the lens 500, or located in proximity to the lens 500, for example, near the lens 500 but is apart from the lens 500 by a narrow gap or a thin material layer. In one embodiment, the housing 200 comprises a lens frame 501, which is configured to fix the lens 500 to the housing

200, and at least a part of the antenna is attached to the lens frame 501. Herein the lens frame 501 may surround the lens 500, or may be arranged along only partial periphery of the lens 500. The lens 500 may be fixedly or detachably connected to the lens frame 501, and may be replaced by another lens 500 when necessary. In some embodiments, there may be no lens frame and the lens is directly connected to the housing at one or more points along its periphery. The part attached to the lens frame 501 in the antenna 100 may refer to the first member 114, the second member 116 and/or the second element 120. In some embodiments, the first member 114, the second member 116 or the second element 120 is not attached to the lens frame 501. In some embodiments, the attachment between the lens 500 or the lens frame 501 and the first member 114, the second member 116 or the second element 120 may refer to that the corresponding member or element is printed on the lens 500 or the lens frame 501.

[0082] Both the lens 500 and the lens frame 501 may provide a region to dispose the antenna 100, especially the first member 114, the second member 116 and/or the second element 120. That is, the housing 200 in proximity to the lens 500 or the part of the lens frame 501 may serve as a part of the aforementioned protruding portion A. In some embodiments, at least a part of the first member 114 is disposed adjacent to the lens 500. In some embodiments, at least a part of the second element 120 may be disposed adjacent to the lens 500. In some embodiments, at least a part of the second member 116 may be disposed adjacent to the lens 500.

[0083] As described above, the shapes and dimensions of the second member 116 and the second element 120 may be tuned to implement wireless communication in various frequency bands. FIG. 7 illustrates a dimension example of the antenna 100 to implement a multi-band (such as, dual-band) wireless communications in 2.4-2.48GHz and 5-7GHz according an antenna as shown in FIG. 6. In FIG. 7, the antenna 100 includes a first antenna 100-1 disposed proximate to the module 300 disposed on a first side, e.g., left side, of the UE 10 and a second antenna 100-2 disposed proximate to the module 300 disposed on a second side, e.g., right side, of the UE 10. Although the antenna 100 is shown to be provided in two in FIG. 7, it is shown by way of illustration only, not limitation, and the number may be 3 or more or may be 1. In this example, the shape of the antenna 100 is as shown in FIGS. 6 and 7 and the dimensions of the antenna 100 is as shown in FIG. 7. The second member 116 is shaped to be straight and the second element 120 is shaped to bent in 'S' shape and has first to fifth parts 122, 124, 126, 128 and 129. The second member 116 has a length of 7mm and width of 2.3 mm. The first part 122 of the second element 120 has a length of 9mm. The second part 124 has a length of 5.5mm. The third part 126 has a length of 8mm. The fourth part 128 has a length of 7mm. The fifth part 129 has a length of 4mm. each of the first to fifth parts 122, 124, 126, 128 and 129 has a width of 1mm.

- [0084] FIGS. 8 and 9 illustrate results of simulation of current distribution of antenna 100-1 and antenna 100-2, as shown in FIG. 7, each under feed having frequencies of 2.44GHz (in 2.4GHz band) and 5.5GHz and 6.5GHz (in 5-7GHz band). In FIGS. 8 and 9, (a) shows current distribution corresponding to the 2.44GHz feed, (b) shows current distribution corresponding to the 5.5GHz feed, (c) shows current distribution corresponding to the 6.5GHz feed and (d) shows a reference bar for relative current strength in (a) to (c). As shown in FIGS. 8 and 9, strong current is confined in second element 120 in case of the 2.44GHz feed. Strong current is confined not only in the second element 120 but also in the second member 116 as well as conductive area (metal area) around the antenna 100 in cases of the 5.5GHz and 6.5GHz feeds. There is little interference between the two antennas during the wireless communication within the two frequency bands.
- [0085] FIG. 10 illustrates a result of simulation of impedances (S11 and S22) of the antennas 100-1 and 100-2 as shown in FIGS. 6 and 7 and isolation therebetween throughout 2.4GHz and 5-7GHz bands. It shows that in both the antenna 100-1 and the antenna 100-2, the resonance frequencies are in 2.4-2.48GHz and 5.15-7.15GHz and the isolation between the antenna 100-1 and the antenna 100-2 is under -30dB, which provides quite ideal quality for wireless signals.
- [0086] FIG. 11 illustrates a result of simulation of efficiencies of the antennas 100-1 and 100-2 as shown in FIGS. 6 and 7 throughout 2.4GHz and 5-7GHz bands. As shown in FIG. 11, both of the antenna 100-1 and the antenna 100-2 have efficiency of about -6dB in 2.4GHz band and about -4 to -5dB in 5-7GHz band, which provides quite ideal quality for wireless signals.
- [0087] FIGS. 12 and 13 illustrates results of simulation of radiation patterns of the antennas 100-1 and 100-2 as shown in FIGS. 6 and 7, each under feed having frequencies of 2.44GHz (in 2.4GHz band) and 5.5GHz and 6.5GHz (in 5-7GHz band). The upper drawing shows the top view of the radio patterns and the lower drawing shows the side view of the radio patterns. The simulation results show quite ideal radiation patterns and good performance.
- [0088] As shown in above, the results of the simulation show that the multi-band antenna 100 has good antenna characteristics for wireless signals of 2.4GHz and 5-7GHz which are quite common in, for example, Bluetooth and Wi-Fi standards.
- [0089] It is appreciated that the foregoing embodiments and simulations on specific configuration of the antenna are merely examples. The UE maybe implemented in other forms than a head-mounted device, such as smartphones, pagers, laptop computers, desktop computers, or any computing device supporting wireless communications. Furthermore, in the embodiments that the UE is a head-mounted device. The head-mounted device may be implemented in other forms than eyeglasses,

such as a helmet, a monocle, goggles, a headband, or a VR/AR headset. The antenna may also be applied to any other wearable devices which has lens. The lens and the module may also be implemented in other forms. For example, an electronic helmet may have a mask to bear the image projected from the projector, or other eyeglasses may have a camera located at a right-front or left-front corner for capturing images. Moreover, the antenna may have other shapes or dimensions. Those skilled in the art may apply, various features of antenna described in the above embodiments, *mutatis mutandis*, to other embodiments or implementations to achieve beneficial effects as described above.

[0090] The embodiments of the present disclosure are described in a progressive manner, and each embodiment places emphasis on the difference from other embodiments. Therefore, one embodiment can refer to other embodiments for the same or similar parts.

[0091] According to the description of the disclosed embodiments, those skilled in the art can implement or use the present disclosure. Various modifications made to these embodiments may be obvious to those skilled in the art, and the general principle defined herein may be implemented in other embodiments without departing from the spirit or scope of the present disclosure. Therefore, the present disclosure is not limited to the embodiments described herein but confirms to a widest scope in accordance with principles and novel features disclosed in the present disclosure.

INDUSTRIAL APPLICABILITY

[0092] Various embodiments may be applied to various wearable user equipment, for example, head-mounted devices such as eyeglasses, helmets, monocles, goggles, headbands, or VR, AR, MR or XR headsets, as well as other user equipment configured for wireless communications, such as smartphones, pagers, laptop computers, desktop computers.

Claims

- [Claim 1] A head-mounted device, comprising:
a housing comprising electrically conductive material;
a module comprising a first portion comprising non-electrically conductive material and disposed on a portion of the housing distant from a head of a user when the head-mounted device is worn by the user; and
an antenna disposed proximate to the module.
- [Claim 2] The head-mounted device according to claim 1, wherein the antenna is disposed proximate to the first portion.
- [Claim 3] The head-mounted device according to claim 1, wherein the module further comprises a second portion comprising electrically conductive material and the antenna is connected to the second portion.
- [Claim 4] The head-mounted device according to claim 3, wherein the antenna comprises:
a first element comprising a feedpoint, a first member disposed on a first side of the feedpoint and connected to the second portion, and a second member disposed on a second side of the feedpoint; and
a second element disposed to be spaced from the second member and connected to the second portion.
- [Claim 5] The head-mounted device according to claim 4, wherein the second member is configured to be fed and the second element is configured to be grounded.
- [Claim 6] The head-mounted device according to claim 4, wherein the second element is spaced from the second member on a side of the second member distant from the feedpoint.
- [Claim 7] The head-mounted device according to claim 4, wherein the first member and the second element are connected to respective distal positions of the second portion.
- [Claim 8] The head-mounted device according to claim 4, wherein an edge of the second element and an edge of the second member turn to each other.
- [Claim 9] The head-mounted device according to claim 4, wherein the second member has a length shorter than that of the second element.
- [Claim 10] The head-mounted device according to claim 4, wherein the first element is configured to operate in a first frequency and the second element is configured to operate in the first frequency and a second frequency.

- [Claim 11] The head-mounted device according to claim 10, wherein the first frequency is higher than the second frequency.
- [Claim 12] The head-mounted device according to claim 1, wherein the module is selected from at least any one of a group consisting of an optical module and a camera module.
- [Claim 13] The head-mounted device according to claim 1, wherein the electrically conductive material comprises metal.
- [Claim 14] The head-mounted device according to claim 1, wherein the non-electrically conductive material comprises plastic.
- [Claim 15] An antenna comprising:
a first element comprising:
a feedpoint,
a first member disposed on a first side of the feedpoint and connected to a portion of a user equipment comprising electrically conductive material, and
a second member disposed on a second side of the feedpoint; and
a second element disposed to be spaced from the second member and connected to another portion of the user equipment comprising electrically conductive material.
- [Claim 16] The antenna according to claim 15, wherein the second member is configured to be fed and the second element is configured to be grounded.
- [Claim 17] The antenna according to claim 15, wherein the second element is spaced from the second member on a side of the second member distant from the feedpoint.
- [Claim 18] The antenna according to claim 15, wherein the portion and the another portion are distant from each other.
- [Claim 19] The antenna according to claim 15, wherein an edge of the second element and an edge of the second member turn to each other.
- [Claim 20] The antenna according to claim 15, wherein the first element is configured to operate in a first frequency and the second element is configured to operate in the first frequency and a second frequency lower than the first frequency.
- [Claim 21] A user equipment comprising:
a first portion comprising non-electrically conductive material;
a second portion comprising electrically conductive material; and
an antenna disposed proximate to the first portion comprising:

a first element comprising:

a feedpoint,

a first member disposed on a first side of the feedpoint and connected to a first position of the second portion and

a second member disposed on a second side of the feedpoint; and

a second element disposed to be spaced from the second member and connected to a second position of the second portion.

[Claim 22] The user equipment according to claim 21, wherein the second member is configured to be fed and the second element is configured to be grounded.

[Claim 23] The user equipment according to claim 21, wherein the first position and the second position are distant from each other.

[Claim 24] The user equipment according to claim 21, wherein an edge of the second element and an edge of the second member turn to each other.

[Claim 25] The user equipment according to claim 21, wherein the first element is configured to operate in a first frequency and the second element is configured to operate in the first frequency and a second frequency lower than the first frequency.

[Fig. 1]

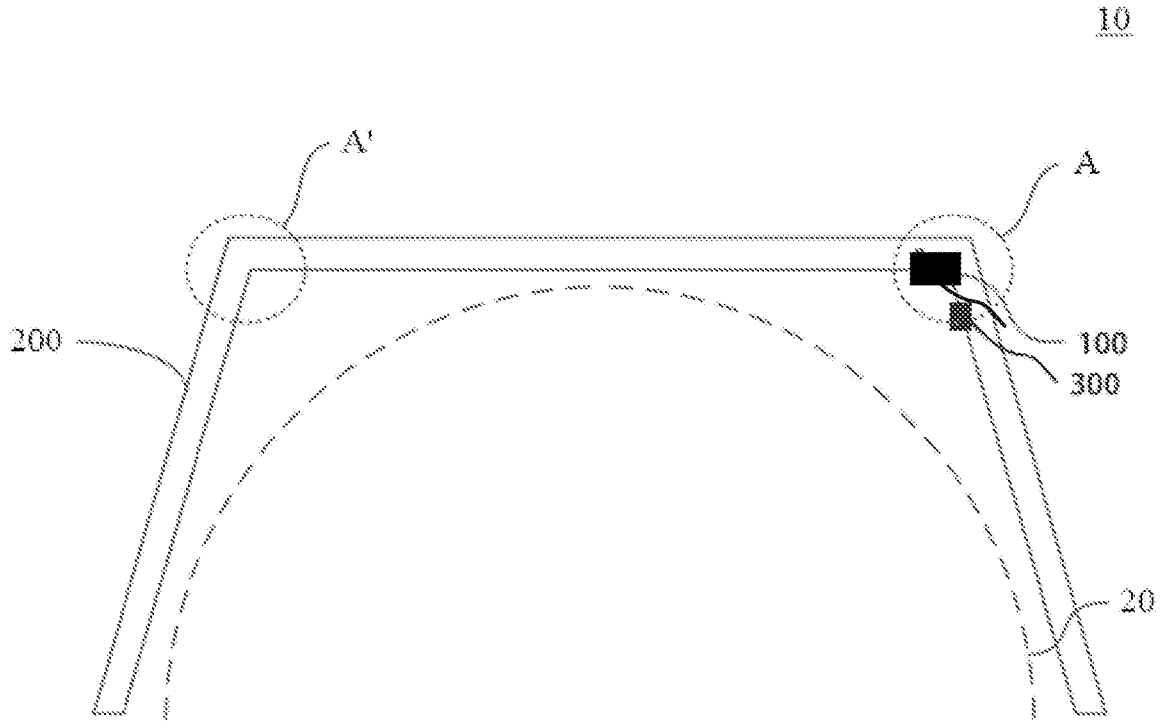

[Fig. 2]

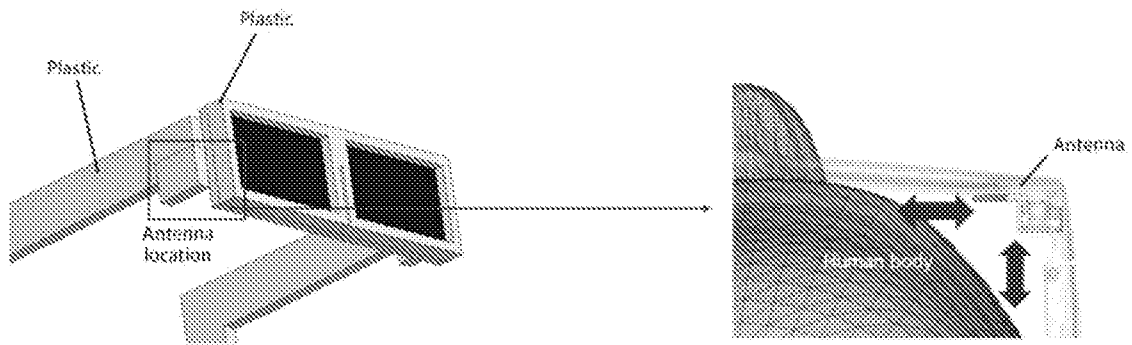

[Fig. 3]

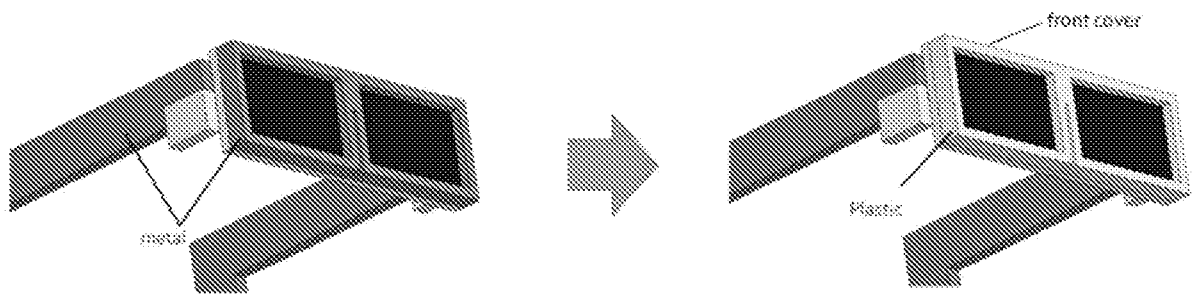

If used same location,
metal cannot be used as front cover material.

[Fig.4]

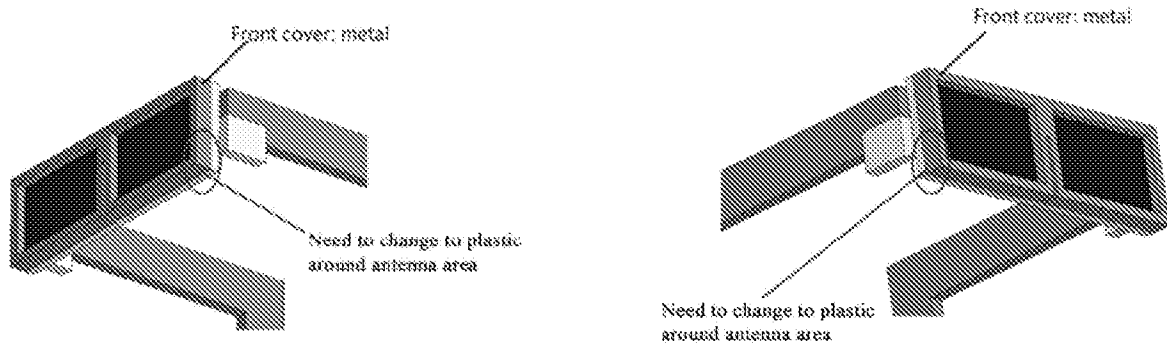

[Fig. 5]

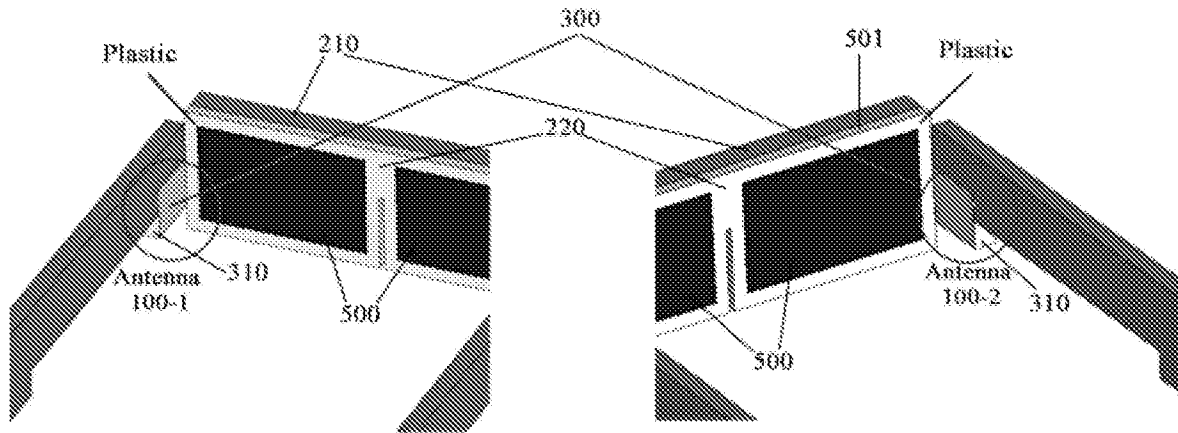

[Fig. 6]

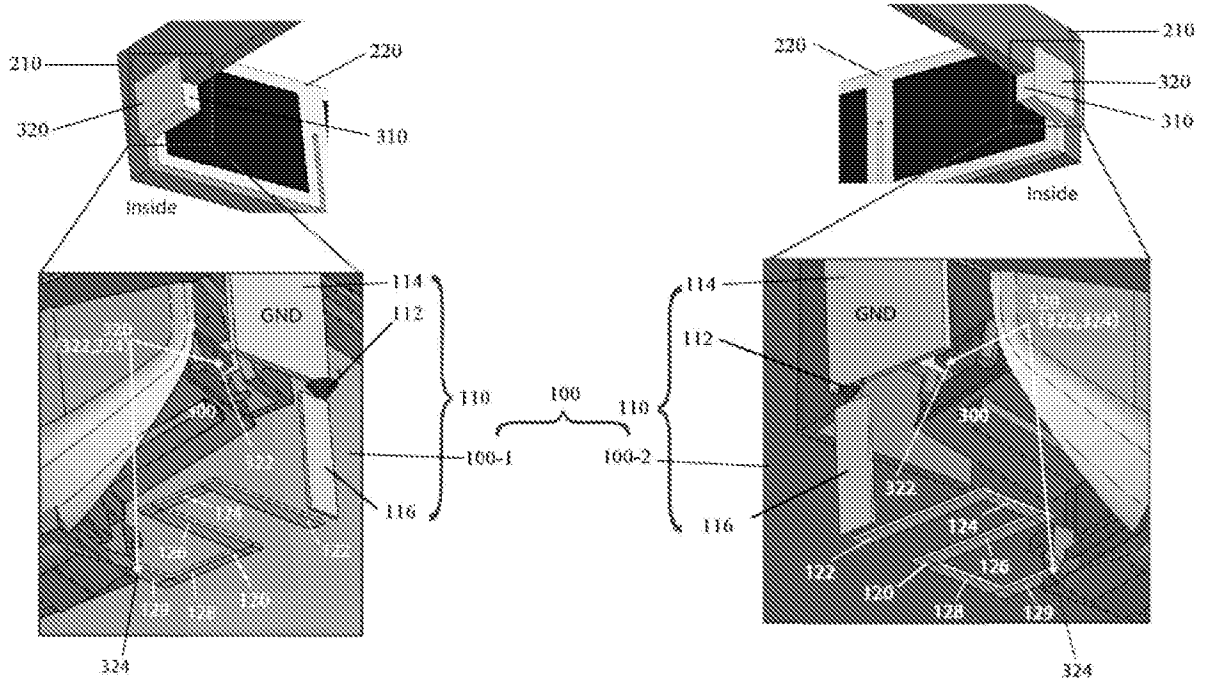

[Fig. 7]

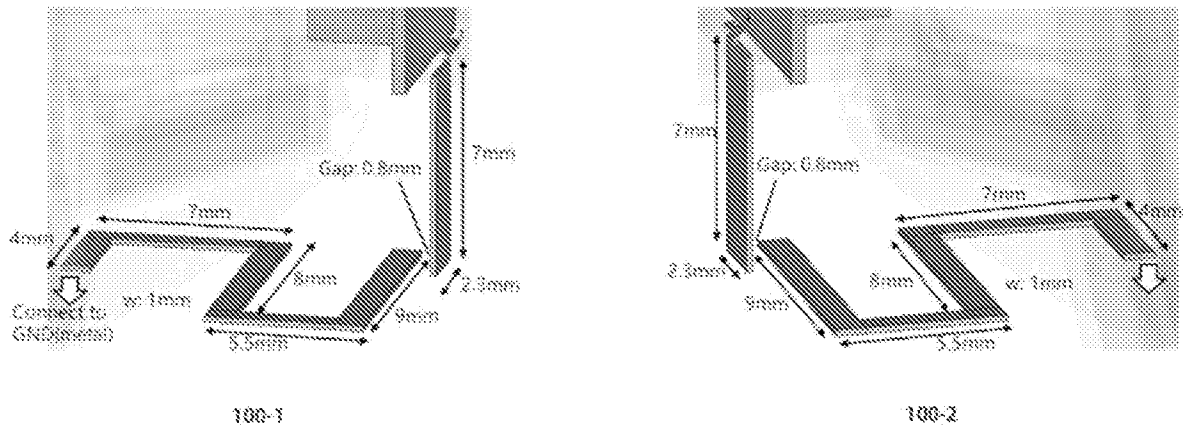

[Fig.8]

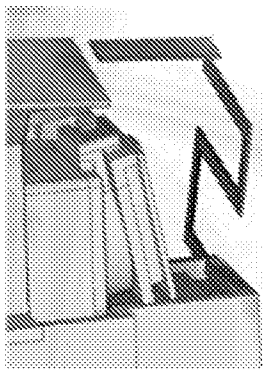
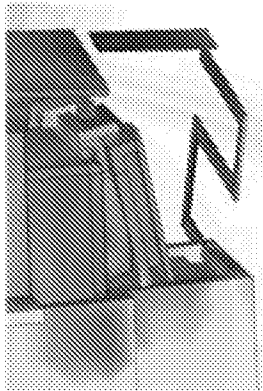
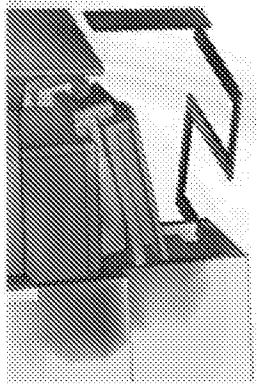

100-1

[Fig. 9]

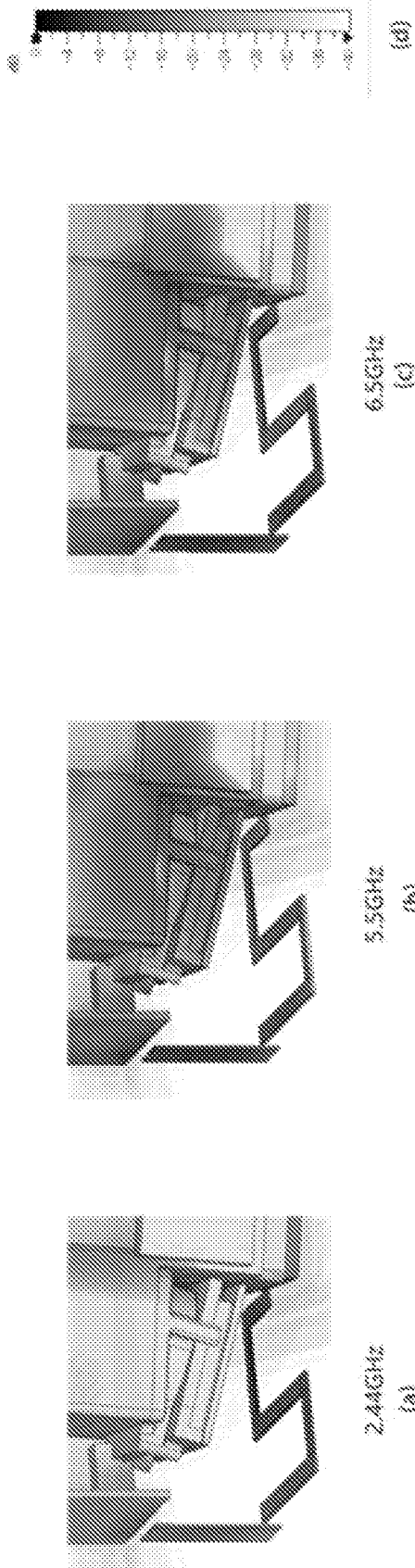

[Fig. 10]

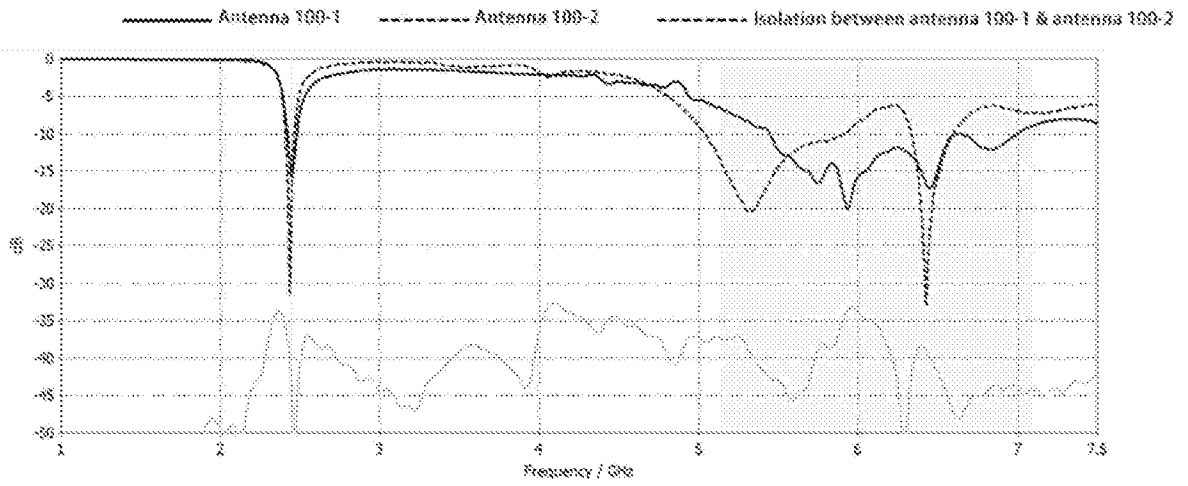

[Fig. 11]

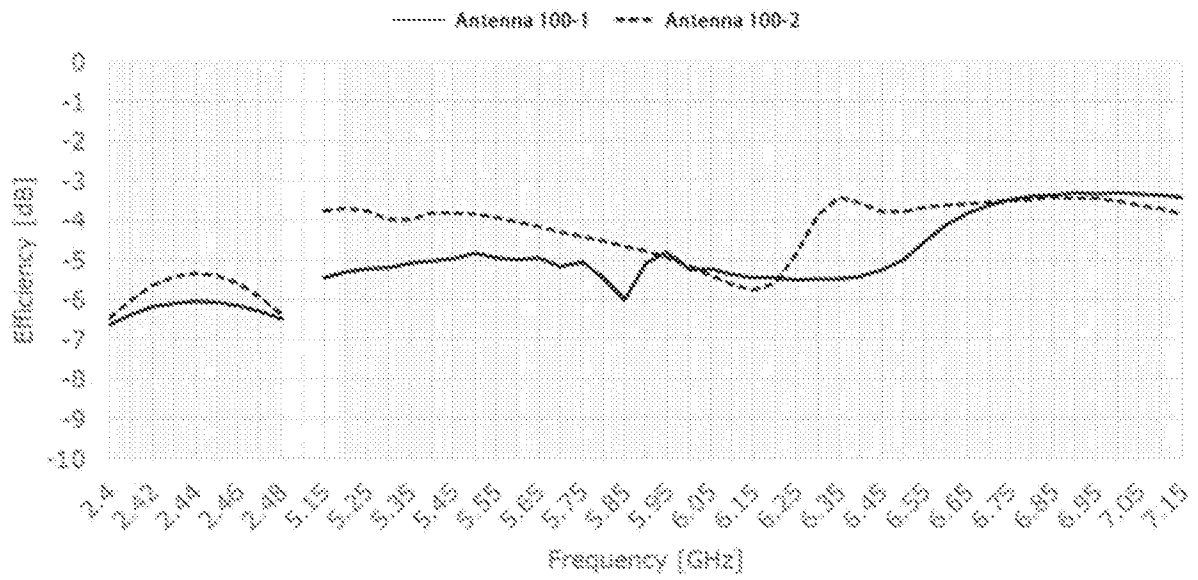

[Fig. 12]

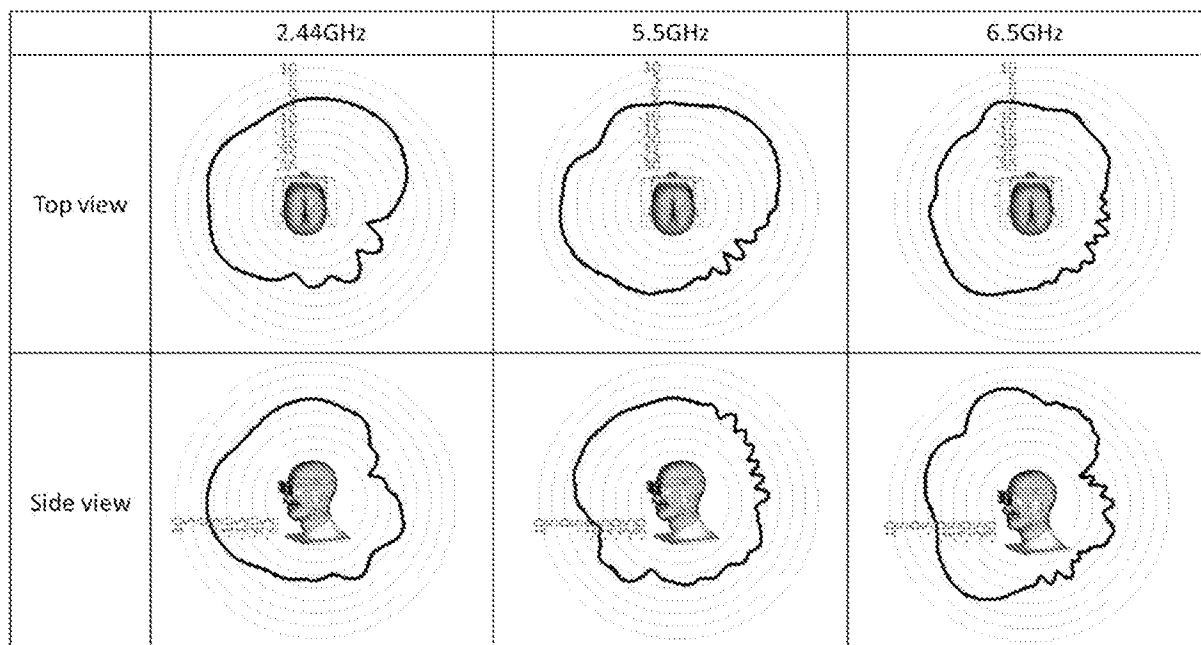

[Fig. 13]

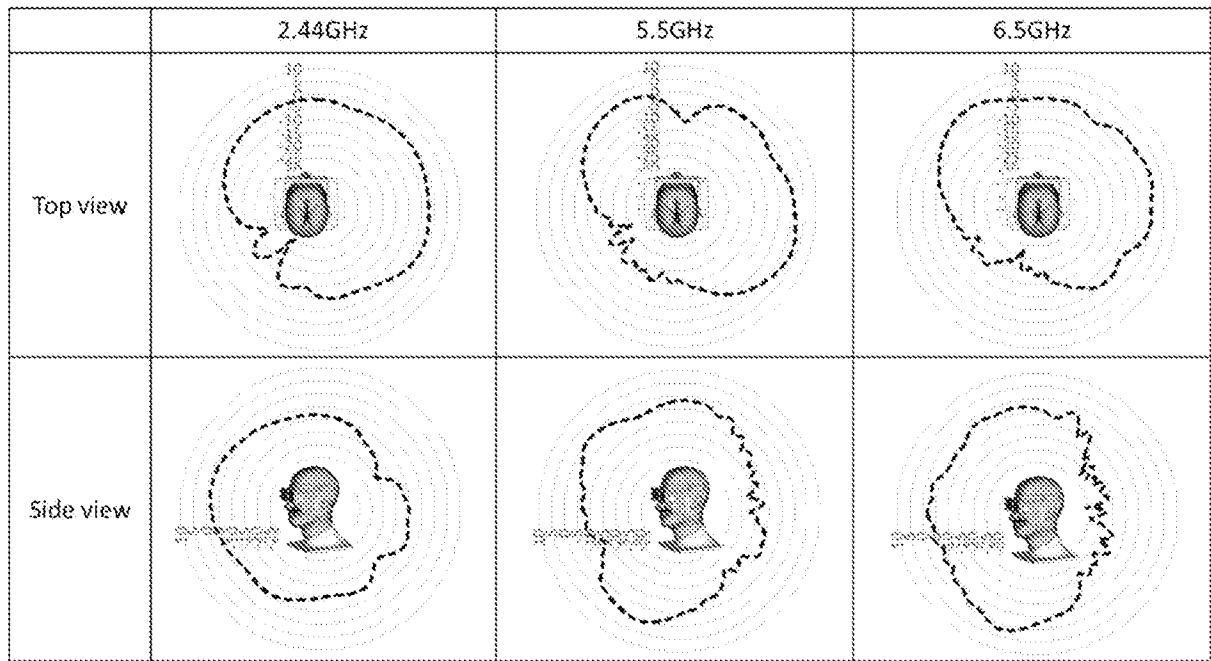

INTERNATIONAL SEARCH REPORT

International application No.

PCT/CN2023/098816

A. CLASSIFICATION OF SUBJECT MATTER		
H01Q1/27(2006.01)i		
According to International Patent Classification (IPC) or to both national classification and IPC		
B. FIELDS SEARCHED		
Minimum documentation searched (classification system followed by classification symbols)		
IPC: H01Q		
Documentation searched other than minimum documentation to the extent that such documents are included in the fields searched		
Electronic data base consulted during the international search (name of data base and, where practicable, search terms used)		
CNTXT, ENTXT, CNKI: antenna, HMD, head mounted display, AR, VR, housing, case, cover, gnd, ground, feed		
C. DOCUMENTS CONSIDERED TO BE RELEVANT		
Category*	Citation of document, with indication, where appropriate, of the relevant passages	Relevant to claim No.
X	CN 115956326 A (GOERTEK INC.) 11 April 2023 (2023-04-11) paragraphs 0049-0085 of the description, Figures 1-9	1-3, 12-14
Y	CN 115956326 A (GOERTEK INC.) 11 April 2023 (2023-04-11) paragraphs 0049-0085 of the description, Figures 1-9	4-11, 15-25
Y	CN 215418562 U (APPLE INC.) 04 January 2022 (2022-01-04) paragraphs 0057-0061 of the description, Figure 2	4-11, 15-25
A	CN 106876977 A (NUBIA TECHNOLOGY CO., LTD.) 20 June 2017 (2017-06-20) the whole document	1-25
A	CN 112768904 A (REALME CHONGQING MOBILE TELECOM CORP. LTD.) 07 May 2021 (2021-05-07) the whole document	1-25
A	US 2017025743 A1 (GALTRONICS CORP. LTD.) 26 January 2017 (2017-01-26) the whole document	1-25
A	US 9496601 B1 (GOOGLE INC.) 15 November 2016 (2016-11-15) the whole document	1-25
<input type="checkbox"/> Further documents are listed in the continuation of Box C. <input checked="" type="checkbox"/> See patent family annex.		
* Special categories of cited documents: "A" document defining the general state of the art which is not considered to be of particular relevance "D" document cited by the applicant in the international application "E" earlier application or patent but published on or after the international filing date "L" document which may throw doubts on priority claim(s) or which is cited to establish the publication date of another citation or other special reason (as specified) "O" document referring to an oral disclosure, use, exhibition or other means "P" document published prior to the international filing date but later than the priority date claimed "T" later document published after the international filing date or priority date and not in conflict with the application but cited to understand the principle or theory underlying the invention "X" document of particular relevance; the claimed invention cannot be considered novel or cannot be considered to involve an inventive step when the document is taken alone "Y" document of particular relevance; the claimed invention cannot be considered to involve an inventive step when the document is combined with one or more other such documents, such combination being obvious to a person skilled in the art "&" document member of the same patent family		
Date of the actual completion of the international search		Date of mailing of the international search report
05 November 2023		13 November 2023
Name and mailing address of the ISA/CN		Authorized officer
CHINA NATIONAL INTELLECTUAL PROPERTY ADMINISTRATION 6, Xitucheng Rd., Jimen Bridge, Haidian District, Beijing 100088, China		SHI,MinFeng Telephone No. (+86) 010-53962413

INTERNATIONAL SEARCH REPORT
Information on patent family members

International application No.

PCT/CN2023/098816

Patent document cited in search report			Publication date (day/month/year)	Patent family member(s)			Publication date (day/month/year)
CN	115956326	A	11 April 2023	WO	2023108521	A1	22 June 2023
CN	215418562	U	04 January 2022	WO	2021211266	A1	21 October 2021
				JP	2023521205	A	23 May 2023
				US	2021328346	A1	21 October 2021
				KR	20220154206	A	21 November 2022
				DE	112021002376	T5	23 February 2023
				CN	115398748	A	25 November 2022
CN	106876977	A	20 June 2017	None			
CN	112768904	A	07 May 2021	WO	2021088712	A1	14 May 2021
US	2017025743	A1	26 January 2017	TW	201607141	A	16 February 2016
				WO	2015166345	A2	05 November 2015
US	9496601	B1	15 November 2016	US	10734706	B1	04 August 2020
				US	2017040666	A1	09 February 2017
				US	9960477	B2	01 May 2018