



(51) International Patent Classification:

H02K 53/00 (2006.01) H02K 1/34 (2006.01)
H02K 7/18 (2006.01) H02K 35/02 (2006.01)
H02K 35/00 (2006.01)

(21) International Application Number:

PCT/AU2019/051005

(22) International Filing Date:

20 September 2019 (20.09.2019)

(25) Filing Language:

English

(26) Publication Language:

English

(30) Priority Data:

2018903528 20 September 2018 (20.09.2018) AU

(71) Applicant: PHAANIX PTY LTD [AU/AU]; 62 Clarendon Street, Newtown, Victoria 3220 (AU).

(72) Inventor: OWENS, Daniel; c/o Phaenix Pty Ltd, 62 Clarendon Street, Newtown, Victoria 3220 (AU).

(74) Agent: SPRUSON & FERGUSON; GPO BOX 3898, Sydney, New South Wales 2001 (AU).

(81) Designated States (unless otherwise indicated, for every kind of national protection available): AE, AG, AL, AM, AO, AT, AU, AZ, BA, BB, BG, BH, BN, BR, BW, BY, BZ, CA, CH, CL, CN, CO, CR, CU, CZ, DE, DJ, DK, DM, DO, DZ, EC, EE, EG, ES, FI, GB, GD, GE, GH, GM, GT, HN, HR, HU, ID, IL, IN, IR, IS, JO, JP, KE, KG, KH, KN, KP, KR, KW, KZ, LA, LC, LK, LR, LS, LU, LY, MA, MD, ME, MG, MK, MN, MW, MX, MY, MZ, NA, NG, NI, NO, NZ, OM, PA, PE, PG, PH, PL, PT, QA, RO, RS, RU, RW, SA, SC, SD, SE, SG, SK, SL, SM, ST, SV, SY, TH, TJ, TM, TN, TR, TT, TZ, UA, UG, US, UZ, VC, VN, ZA, ZM, ZW.

(84) Designated States (unless otherwise indicated, for every kind of regional protection available): ARIPO (BW, GH,

(54) Title: ENERGY GENERATION

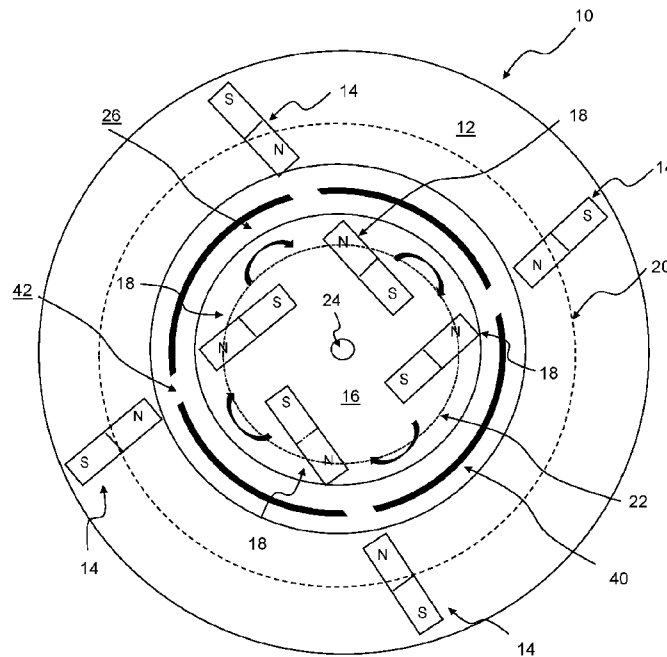

FIG 1

(57) Abstract: An energy generation apparatus comprises a first element comprising at least one first magnet and a second element comprising at least one second magnet. The second element is movable with respect to the first element. The at least one first magnet and the at least one second magnet are oriented such that common poles of the at least one first and second magnets are temporarily in proximity to each other such that a repulsive magnetic force between the at least one first magnet and at least one second magnet causes relative motion between the first and second elements. Preferred embodiments of the apparatus comprise at least one positioning element or cam comprising an undulating or wave-like surface to control a position and/or an orientation of the at least one first magnet and/or the at least one second magnet.



WO 2020/056464 A1

GM, KE, LR, LS, MW, MZ, NA, RW, SD, SL, ST, SZ, TZ,
UG, ZM, ZW), Eurasian (AM, AZ, BY, KG, KZ, RU, TJ,
TM), European (AL, AT, BE, BG, CH, CY, CZ, DE, DK,
EE, ES, FI, FR, GB, GR, HR, HU, IE, IS, IT, LT, LU, LV,
MC, MK, MT, NL, NO, PL, PT, RO, RS, SE, SI, SK, SM,
TR), OAPI (BF, BJ, CF, CG, CI, CM, GA, GN, GQ, GW,
KM, ML, MR, NE, SN, TD, TG).

Published:

— *with international search report (Art. 21(3))*

TITLEENERGY GENERATIONFIELD OF THE INVENTION

5 The present invention relates to energy generation. In particular, embodiments of the present invention relate to systems, methods and apparatus for energy generation, in particular comprising magnets.

BACKGROUND TO THE INVENTION

10 There is a continued search for new systems, methods and apparatus for energy generation to meet the world's increasing energy demands and to generate energy in a more sustainable, environmentally friendly manner. Solar, wind, wave, tidal, hydroelectric and geothermal energy generation systems, methods and apparatus have been developed as some renewable approaches to
15 energy generation which are replacing some traditional methods of energy generation including such methods that rely on fossil fuels. However, new energy generation systems, methods and apparatus are required to supplement existing renewable systems, methods and apparatus in an effort to reduce reliance on fossil fuels and to curtail harmful emissions and environmental damage.

20

OBJECT OF THE INVENTION

A preferred object of the present invention is to provide systems and/or methods and/or apparatus for energy generation that address or at least ameliorate one or more of the aforementioned problems and/or provide a useful
5 commercial alternative.

SUMMARY OF THE INVENTION

The present invention concerns systems, methods and apparatus for energy generation, in particular comprising a configuration or arrangement of
10 magnets that create motion, such as, but not limited to rotational, linear or oscillating motion between two or more elements.

According to one aspect, but not necessarily the broadest aspect, the present invention is directed to an energy generation apparatus comprising:

a first element comprising at least one first magnet;

15 a second element comprising at least one second magnet, the second element movable with respect to the first element;

wherein the at least one first magnet and the at least one second magnet are oriented such that common poles of the first and second magnets are temporarily in proximity to each other such that a repulsive magnetic force
20 between the at least one first magnet and at least one second magnet causes relative motion between the first element and the second element.

Suitably, the repulsive magnetic force causes the second element to move with respect to the first element or the first element to move relative to the second element or both the first and second elements to move.

In some embodiments, the second element is rotatable with respect to the first element such that when common poles of the at least one first magnet and the at least one second magnet are temporarily in proximity to each other, the repulsive magnetic force causes the second element to rotate with respect to the first element.

In some embodiments, the second element exhibits reciprocating linear motion with respect to the first element such that when common poles of the at least one first magnet and the at least one second magnet are temporarily in proximity to each other, the repulsive magnetic force causes the second element to move linearly with respect to the first element.

Suitably, the first element comprises a plurality of first magnets.

Suitably, the second element comprises a plurality of second magnets.

Suitably, the magnets of the plurality of first magnets are spaced apart on the first element. In some embodiments, the first magnets are spaced equal distances apart, or substantially equal distances apart. In a preferred embodiment, the first magnets are spaced equal distances, or substantially equal distances about a perimeter of the second element, such as a circumference of a circular path on the first element.

Suitably, the magnets of the plurality of second magnets are spaced apart on the second element. In some embodiments, the second magnets are spaced

equal distances apart, or substantially equal distances apart. In a preferred embodiment, the second magnets are spaced equal distances, or substantially equal distances about a perimeter of the second element, such as a circumference of a circular path on the second element.

5 Suitably, the north poles of the at least one first magnet and the at least one second magnet are temporarily in proximity to each other.

Suitably, the south poles of the at least one first magnet and the at least one second magnet are temporarily in proximity to each other.

10 Suitably, the at least one first magnet is mounted to the first element and the at least one second magnet is mounted to the second element in an orientation to maximise the magnetic repulsive force in a direction of motion of the second element. In some embodiments, the at least one first and second magnets are mounted to the first and second elements respectively to maximise rotational velocity of the second element.

15 Suitably, the first element is fixed.

Suitably, the second element is mounted on at least one frictionless bearing.

20 In some embodiments, the second element is spaced apart from the first element. Suitably, the apparatus comprises an air gap between the first and second elements. More preferably, the apparatus comprises a vacuum between the first and second elements.

In some embodiments, the energy generation apparatus comprises a magnetic shield element between the at least one first magnet mounted to the first

element and the at least one second magnet mounted to the second element, the magnetic shield element comprising at least one aperture or opening therein at or around a location at which the at least one first magnet and the at least one second magnet is aligned.

5 In some embodiments the energy generation apparatus comprises at least one positioning element, or cam to control a position and/or an orientation of the at least one first magnet and/or the at least one second magnet.

 Suitably, the at least one positioning element, or cam controls a position and/or an orientation of the at least one second magnet mounted to the second
10 element.

 Preferably, the at least one positioning element comprises an undulating or wavelike surface and in particular a surface with sinusoidal surface variations comprising multiple lobes and troughs to move the at least one second magnet closer to the at least one first magnet when the magnets are temporarily in
15 proximity to each other and further away from each other at other times.

 Suitably, the positioning element or cam comprises a central aperture to receive the second element therein.

 Suitably, the positioning element or cam is fixed below the second magnets such that undersides of the second magnets rest on the undulating or wavelike
20 surface.

 Suitably, the second magnets are movably mounted by a flexible arm, a hinge or the like such that as the second element rotates relative to the first element due to the repulsive magnetic force between the first and second

magnets, the second element 16 rotates relative to the positioning element or cam causing the second magnets to move up and down as they pass over the undulating or wavelike surface of the positioning element or cam.

Suitably, a periodicity of the lobes and troughs of the undulating or wavelike surface coincides with the number and arrangement of magnets such that the
5 second magnets are moved closer to the first magnets when the magnets are temporarily in proximity to each other and further away from each other at other times.

Suitably, an axis of rotation of the second element is variable to allow the
10 second magnets to move closer to the first magnets when the magnets are temporarily in proximity to each other and further away from each other at other times.

Suitably, the second element comprises one or more flexible or hinged arms or levers that pass over one or more raised areas via a bearing or brush to
15 maximise the repulsive forces and minimises the attractive forces of the first and second magnets.

Suitably, the second element comprises one or more pairs of flexible or hinged arms or levers whereby when one of the pair of arms or levers is not being caused to move by the repulsion of two magnets in proximity to each other, the
20 other arm or lever of the same pair of arms or lever is being caused to move by the repulsion of two other magnets in proximity to each other.

Suitably, the apparatus may comprise a pair of spaced apart second elements in the form of rotating discs comprising a plurality of second magnets, a

central static disc between the two second elements, and at least one elongate first magnet extending between the two second elements at an angle through the central static disc such that opposite poles of the elongate first magnet are on opposite sides of the second elements.

5 The apparatus may further comprise at least one converter in communication with the movable second element to convert kinetic energy of the second element into electrical energy. The at least one converter may include a dynamo, a turbine, or a generator.

 The electrical energy may be stored, for example, in a rechargeable
10 battery, transmitted to an electrical network or grid, or used by a device in communication with the apparatus or which the apparatus is a part.

 According to another aspect, but not necessarily the broadest aspect, the present invention is directed to a method of energy generation comprising using the aforementioned apparatus.

15 According to another aspect, but not necessarily the broadest aspect, the present invention is directed to a method of energy generation comprising:

 mounting at least one first magnet to a first element;

 mounting at least one second magnet to a second element, wherein the second element is movable with respect to the first element;

20 orienting the at least one first magnet and the at least one second magnet such that common poles of the first and second magnets are temporarily in proximity to each other causing a repulsive magnetic force between the at least

one first magnet and at least one second magnet to cause relative motion between the first and second elements; and

converting kinetic energy of the moving first and/or second elements into electrical energy with at least one converter in communication with the first and/or
5 second element.

Further features and/or aspects of the present invention will become apparent from the following detailed description.

BRIEF DESCRIPTION OF THE DRAWINGS

10 Embodiments of the present invention will now be described by way of example only with reference to the accompanying drawings in which like reference numerals refer to like features. In the drawings:

FIG 1 is a plan view of an energy generation apparatus according to some embodiments of the present invention;

15 FIG 2 is a schematic diagram of the apparatus shown in FIG 1 as part of an energy generation system;

FIG 3 is a general flow diagram illustrating methods of energy generation using the apparatus shown in FIG 1;

20 FIG 4 is a side view of an energy generation apparatus according to other embodiments of the present invention;

FIG 5 is a perspective view of a positioning element or cam according to some embodiments of the present invention; and

FIG 6 is a schematic illustration of an energy generation apparatus according to some other embodiments of the present invention.

Skilled addressees will appreciate that elements in the drawings are illustrated for simplicity and clarity and have not necessarily been drawn to scale.

5 For example, the relative dimensions of some of the elements in the drawings may be distorted and/or some elements may be omitted to help improve understanding of embodiments of the present invention.

DETAILED DESCRIPTION

10 Embodiments of the present invention are directed to systems, methods and apparatus for energy generation, in particular comprising a configuration or arrangement of magnets that create motion, such as, but not limited to rotational, linear or oscillating motion.

Reference is made to FIG 1, which show an energy generation apparatus
15 10 according to embodiments of the present invention. The energy generation apparatus 10 comprises a first element 12 comprising at least one first magnet 14 and a second element 16 comprising at least one second magnet 18. The second element 16 is movable with respect to the first element 12. The at least one first magnet 14 and the at least one second magnet 18 are oriented such that common
20 poles of the first and second magnets 14, 18 are temporarily in proximity to each other such that a repulsive magnetic force between the at least one first magnet 14 and the at least one second magnet 18 causes relative motion between the first and second elements, and in this embodiment, the second element 16 to move with respect to the first element 12. The orientation of the first and second

magnets 14, 18 to cause the relative motion of the first and second elements can be achieved in a variety of ways which will be described herein.

In some embodiments, such as the embodiment shown in FIG 1, the second element 16 is rotatable with respect to the first element 12 such that when
5 common poles of the at least one first magnet 14 and the at least one second magnet 18 are temporarily in proximity to each other, the repulsive magnetic force between the common poles causes the second element 16 to rotate with respect to the first element 12.

The common poles can be the north poles or the south poles of the
10 magnets. Therefore, the repulsive force can be achieved when the north poles of the at least one first magnet 14 and the at least one second magnet 16 are temporarily in proximity to each other. Alternatively, the repulsive force can be achieved when the south poles of the at least one first magnet 14 and the at least one second magnet 18 are temporarily in proximity to each other.

As shown in the embodiment of FIG. 1, the first element 12 comprises a
15 plurality of first magnets 14 and the second element 16 comprises a plurality of second magnets 18. In the embodiment shown in FIG. 1, the first element 12 comprises four first magnets 14 and the second element 16 comprises four second magnets 18. However, fewer or more first and second magnets 14, 18 can
20 be used. In some embodiments, a continuous series of first magnets 14 can be provided on the first element 12 and a continuous series of second magnets 18 can be provided on the second element 16.

With reference to FIG. 1, the magnets of the plurality of first magnets 14 are spaced apart on the first element 12. In some embodiments, the first magnets

14 are spaced equal distances apart, or substantially equal distances apart. In a preferred embodiment, the first magnets 14 are spaced equal distances, or substantially equal distances about a circumference of a first circular path 20 on the first element 12.

5 As shown in FIG 1, the magnets of the plurality of second magnets 18 are spaced apart on the second element 16. In some embodiments, the second magnets 18 are spaced equal distances apart, or substantially equal distances apart. In a preferred embodiment, the second magnets 18 are spaced equal distances, or substantially equal distances about a circumference of a second
10 circular path 22 on the second element 16.

It will be appreciated that the present invention is not limited to the first or second elements being circular and therefore in embodiments in which the first and/or second elements are non-circular, the magnets can be mounted to the respective first and/or second elements, for example, about a perimeter of the first
15 and/or second elements.

With reference to FIG 1, the first magnets 14 are mounted to the first element 12 and the at least one second magnet 18 is mounted to the second element 16 in an orientation to maximise the magnetic repulsive force in a direction of motion of the second element 16. In some embodiments, the at least
20 one first and second magnets 14, 18 are mounted to the first and second elements respectively to maximise rotational velocity of the second element.

In the embodiment shown in FIG 1, the second magnets 18 are equally spaced on the second element 16 such that all four of the second magnets 18 are simultaneously aligned with the first magnets 14 on the first element 12. Hence,

simultaneously, each of the four second magnets 18 is repelled by a respective first magnet 14 on the first element 12 thus maximising the instantaneous magnetic repulsive force and causing rotation of the second element 16 with respect to the first element 12 in a clockwise direction.

5 It will be appreciated that in the embodiment shown in FIG 1, the first element 12 is fixed and the second element 16 is rotatable with respect to, or relative to the first element 12.

 In other embodiments, the second element 16 is fixed and the first element 12 is rotatable relative to the second element 16. In such an embodiment, the
10 angles and orientation of the magnets may be varied from that shown in FIG 1.

 In some embodiments, it is envisaged that neither the first element 12 nor the second element 16 is fixed and the repulsive magnetic force between the first and second magnets 14, 18 causes both the first and second elements to move.

 In the embodiment shown in FIG 1, the second element 16 is mounted on
15 at least one frictionless bearing 24 to maximise the kinetic energy of the second element 16.

 In some embodiments, as shown in FIG 1, the second element 16 is spaced apart from the first element by a gap 26. The size of the gap 26 will depend on the particular application of the apparatus. In some embodiments of
20 the apparatus 10, the gap 26 comprises an air gap between the first and second elements 12, 16. In some preferred embodiments, the apparatus 10 comprises a vacuum between the first and second elements 12,16 to further reduce friction or drag that may be caused by air currents.

With reference to FIG 2, the apparatus 10 further comprises at least one converter 28 in communication with the movable second element 16 to convert kinetic energy of the second element 16 into another form of energy, such as electrical energy. The at least one converter 28 can include a dynamo, a turbine,
5 or a generator.

The electrical energy may be stored, for example, in a rechargeable battery 30, transmitted to an electrical network or grid 32, or used by a device 34 in communication with the apparatus or of which the apparatus 10 is a part.

In alternative embodiments, the first and second magnets 14, 18 are not all
10 aligned simultaneously. For example, the first and second magnets 14, 18 can be arranged such that at least one first magnet 14 and at least one second magnet 18 are aligned at any one time. In this way, a more constant repulsive force between the first and second magnets 14, 18 can be achieved rather than a pulsing, or temporally varying repulsive force. It should also be appreciated that
15 the present invention is not limited to the first element 12 and the second element 16 comprising the same number of first and second magnets 14, 18 respectively. In some embodiments, the first element 12 can comprise more first magnets 14 than the second element 16 comprises second magnets 18. In some embodiments, the second element 16 can comprise more second magnets 18
20 than the first element 12 comprises first magnets 18.

It is also envisaged that in some embodiments, the apparatus 10 comprises multiple levels of first and second magnets 14, 18. For example, the first element 12 can comprise a first level of first magnets 14 and a second level of first magnets 14. Correspondingly, the second element 16 can comprise a first

level of second magnets 18 and a second level of second magnets 18. The first level of first magnets 14 on the first element 12 align, at least temporarily, with the first level of second magnets 18 on the second element 16 and the second level of first magnets 14 on the first element 12 align, at least temporarily, with the second level of second magnets 18 on the second element 16. The number of levels, the number of magnets and the spacing of the magnets can be selected to determine the strength and time variation of the repulsive forces between the first and second magnets.

In some embodiments, the energy generation apparatus 10 comprises a magnetic shield element 40 between the at least one first magnet 14 mounted to the first element 12 and the at least one second magnet 18 mounted to the second element 16. The magnetic shield element 40 comprises at least one aperture or opening 42 therein at or around a location at which the at least one first magnet 14 and the at least one second magnet 18 are aligned. In the embodiment shown in FIG 1, magnetic shield element 40 comprises four apertures or openings 42 therein at locations where each pair of first and second magnets 14, 18 are aligned. The magnetic shield element 40 is made of any suitable material which conducts lines of magnetic flux better than the surrounding medium, i.e. has a high magnetic permeability compared with the surrounding medium. Examples of materials that can be suitable for the magnetic shield element 40 include, but are not limited to mu-metal, permalloys and other known materials with a high magnetic permeability. Consequently, the magnetic shield element 40 shields the magnetic field between the first and second magnets 14, 18 when the first and second magnets 14, 18 are not aligned to reduce any resistance caused by any attraction between opposite poles of the magnets 14,

18. The apertures or openings 42 in the magnetic shield element 40 allow the first and second magnets 14, 18 to repel when aligned.

With reference to FIG 5, in some embodiments, the energy generation apparatus 10 comprises at least one positioning element or cam 44 to control a position and/or an orientation of the at least one first magnet 14 and/or the at least one second magnet 18. In some embodiments, at least one positioning element or cam 44 can control a position and/or an orientation of the at least one second magnet 18 mounted to the second element 16. In some embodiments, at least one positioning element or cam 44 can control a position and/or an orientation of the at least one first magnet 14 mounted to the first element 12. In some embodiments, at least one positioning element or cam 44 controls a position and/or an orientation of the at least one second magnet 18 mounted to the second element 16 and at least one other positioning element or cam controls a position and/or an orientation of the at least one first magnet 14 mounted to the first element 16.

FIG 5 shows positioning element or cam 44 to control at least a position of the second magnets 18 mounted to the second element 16. The positioning element or cam 44 comprises an undulating or wavelike surface 46 and in particular, a surface 46 with sinusoidal surface variations comprising multiple alternately located lobes 48 and troughs 50 to move the second magnets 18 closer to the first magnets 14 when the magnets are temporarily in proximity to each other and further away from each other at other times.

The positioning element or cam 44 comprises a central aperture 52 which allows the second element 16 to be received therein. The positioning element or

cam 44 is fixed below second magnets 18 such that undersides of the second magnets 18 rest on the undulating or wavelike surface 46. In this embodiment, second magnets 18 are movably mounted by any suitable means, for example, on a flexible arm or via a hinge. Hence, as the second element 16 rotates relative to the first element 12 due to the repulsive magnetic force between the first and second magnets 14, 18, the second element 16 rotates relative to the positioning element or cam 44. The second magnets 18 are moved up and down as they pass over the lobes 48 and troughs 50 of the undulating or wavelike surface 46. The periodicity of the lobes 48 and troughs 50 of the undulating or wavelike surface 46 coincides with the number and arrangement of magnets such that the second magnets 18 are moved closer to the first magnets 14 when the magnets are temporarily in proximity to each other and further away from each other at other times. Hence, the repulsive force is maximised, or at least increased due the occasions of closer proximity and any attractive force between the magnets at other times is minimised, or at least reduced.

In some embodiments, the second element 16 is in the form of a rotating disc comprising a plurality of second magnets 18. An axis of rotation of the second element or disc 16 is variable which allows the disc 16 to undulate, or wobble as the disc rotates. The variable axis of rotation allows the second magnets 18 to move closer to the first magnets 14 when the magnets 14, 18 are temporarily in proximity to each other and further away from each other at other times. This maximises the repulsive forces and minimises the attractive forces.

In some embodiments, the second element 16 comprises one or more flexible or hinged arms or levers pass over one or more raised areas via a bearing

or brush to maximise the repulsive forces and minimises the attractive forces. In a variation of this embodiment, one or more pairs of arms or levers can be employed whereby when one of the pair of arms or levers is not being caused to move by the repulsion of two magnets in proximity to each other, the other arm or
5 lever of the same pair of arms or lever is being caused to move by the repulsion of two other magnets in proximity to each other.

In some other embodiments, features of the embodiments described herein can be multiplied to multiply the energy generated. For example, with reference to FIG 6, some embodiments of the energy generation apparatus comprise a pair of
10 spaced apart second elements 16 in the form of rotating discs comprising a plurality of second magnets 18. For clarity, FIG 6 only shows a single second magnet 18 of each disc. The energy generation apparatus comprises a central static disc 56 between the two second elements 16. At least one elongate first magnet 14 extends between the two second elements 16 at an angle through the
15 central static disc 56 such that opposite poles of the long first magnet 14 are on opposite sides of the second elements 16. Hence, the propulsion caused by the repulsive magnetic force of two magnets in proximity to each other is duplicated in each second element.

According to another aspect, the present invention is directed to a method
20 of energy generation comprising using the apparatus 10.

According to a further aspect, and with reference to FIG 3, the present invention is directed to a method 300 of energy generation. At 302, the method comprises mounting at least one first magnet 14 to the first element 12. At 304, the method comprises mounting at least one second magnet 18 to the second

element 16, wherein the second element 16 is movable with respect to the first element 12. At 306, the method comprises orienting the at least one first magnet 14 and the at least one second magnet 18 such that common poles of the first and second magnets 14, 16, such as the north poles or the south poles, are temporarily in proximity to each other causing a repulsive magnetic force between the at least one first magnet 14 and at least one second magnet 16 to cause relative motion between the second element 16 and the first element 12. At 308, the method comprises converting kinetic energy of the moving element into electrical energy with at least one converter 28 in communication with the moving element.

It should be appreciated that the present invention is not limited to the generation of energy through rotational motion caused by magnetic repulsion. In some embodiments, the second element 16 exhibits reciprocating linear motion with respect to the first element 12 such that when common poles of the at least one first magnet 14 and the at least one second magnet 18 are temporarily in proximity to each other, the repulsive magnetic force between the common poles causes the second element 16 to move linearly with respect to the first element 12. For example, with reference to FIG 4, first bar magnets 14 can be placed at, or towards opposite ends of the first element 12, which is in the form of a linear track 36. One of the first magnets 14 has one pole, such as the north pole facing inwards towards the track 36 and the other first magnet 14 has the opposite pole, such as the south pole respectively facing inwards towards the track 36. The second magnet 18 is mounted in a frictionless, or substantially frictionless manner to the track 36, such that the second magnet 18 can slide along the track. In this example, the north pole of the second magnet 18 faces the north pole of one of

the first magnets 14 and the south pole of the second magnet 18 faces the south pole of the other one of the first magnets 14. Hence, when the second magnet 18 is set into linear motion along the track 36, for example, in the direction of the first magnet 14, when in proximity to the first magnet 14, the north pole of the second magnet 18 is repelled by the north pole of the first magnet 14 thus causing the second magnet 18 to be moved in the opposite direction back along the track 36. When in proximity to the other first magnet 14, the south pole of the second magnet 18 is repelled by the south pole of the first magnet 14 thus causing the second magnet 18 to be moved back along the track 36 in the original direction for the cycle to be repeated.

Energy can be generated from the reciprocating linear motion using the aforementioned components for energy conversion and energy storage with any suitable modifications that will be understood by the skilled addressee, but will nonetheless fall within the scope of the present invention.

Hence, embodiments of the present invention address or at least ameliorate at least some of the aforementioned problems. For example, the present invention generates kinetic energy based on the magnetic repulsion between the one or more first and second magnets 14, 18 which is converted, for example, into electrical energy, which is more environmentally considerate than many conventional methods of energy generation using fossil fuels. The present invention involves a straightforward configuration of elements, which is simpler and less costly to implement than many known renewable energy generation systems. Also, the present invention does not rely on prevailing weather conditions for the invention to operate or operate sufficiently, such as sufficient

wind, rainfall, water currents or flow or sufficient solar irradiance. The present invention is also scalable according to the particular application and therefore it is envisaged that the invention can be implemented for both domestic and industrial use.

5 In this specification, the terms, "first", "second" etc. are intended to differentiate between different features of the present invention and are not intended to limit the present invention to a particular order of implementation unless the context indicates otherwise.

 In this specification, the terms "comprises", "comprising" or similar terms
10 are intended to mean a non-exclusive inclusion, such that an apparatus that comprises a list of elements does not include those elements solely but may well include other elements not listed.

 The reference to any prior art in this specification is not, and should not be taken as, an acknowledgement or any form of suggestion that the prior art forms
15 part of the common general knowledge.

 It will be appreciated that the present invention is not limited to the specific embodiments described herein. Skilled addressees will identify variations from the specific embodiments described herein that will nonetheless fall within the scope of the present invention, which is determined by the following claims.

CLAIMS

1. An energy generation apparatus comprising:

a first element comprising at least one first magnet;

5 a second element comprising at least one second magnet,
the second element movable with respect to the first element; and

at least one positioning element or cam comprising an
undulating or wave-like surface to control a position and/or an
orientation of the at least one first magnet and/or the at least one
10 second magnet;

wherein the at least one first magnet and the at least one
second magnet are oriented such that common poles of the first and
second magnets are temporarily in proximity to each other such that
a repulsive magnetic force between the at least one first magnet and
15 at least one second magnet causes relative motion between the first
and second elements.

2. The apparatus of claim 1, wherein the second element is rotatable
with respect to the first element such that when common poles of the
20 at least one first magnet and the at least one second magnet are
temporarily in proximity to each other, the repulsive magnetic force
causes the second element to rotate with respect to the first
element.

3. The apparatus of claim 1, wherein the second element exhibits reciprocating linear motion with respect to the first element such that when common poles of the at least one first magnet and the at least one second magnet are temporarily in proximity to each other, the repulsive magnetic force causes the second element to move linearly with respect to the first element.
- 5
4. The apparatus of any preceding claim, wherein the first element comprises a plurality of first magnets and/or the second element comprises a plurality of second magnets.
- 10
5. The apparatus of claim 4, wherein the magnets of the plurality of first magnets are spaced apart on the first element, such as equal distances apart, or substantially equal distances apart, and optionally about a circumference of a circular path on the first element or a perimeter of the second element.
- 15
6. The apparatus of claim 4, wherein the magnets of the plurality of second magnets are spaced apart on the second element, such as equal distances apart, or substantially equal distances apart, and optionally about a circumference of a circular path on the second element or a perimeter of the second element.
- 20
7. The apparatus of any preceding claim, wherein the north poles of the at least one first magnet and the at least one second magnet are temporarily in proximity to each other, or the south poles of the at
- 25

least one first magnet and the at least one second magnet are temporarily in proximity to each other.

- 5
8. The apparatus of any preceding claim, wherein the at least one first magnet is mounted to the first element and the at least one second magnet is mounted to the second element in an orientation to maximise the magnetic repulsive force in a direction of motion of the second element, and in particular to maximise rotational velocity of the second element.
- 10
9. The apparatus of any preceding claim, wherein: the first element is fixed; and/or the second element is mounted on at least one frictionless bearing.
- 15
10. The apparatus of any preceding claim, wherein the second element is spaced apart from the first element, in particular with an air gap between the first and second elements.
- 20
11. The apparatus of any of claims 1-9, wherein the apparatus comprises a vacuum between the first and second elements.
- 25
12. The apparatus of any preceding claim, further comprising a magnetic shield element between the at least one first magnet mounted to the first element and the at least one second magnet mounted to the second element, the magnetic shield element comprising at least one aperture or opening therein at or around a location at which the

at least one first magnet and the at least one second magnet is aligned.

5 13. The apparatus of any preceding claim, wherein the surface of the positioning element or cam comprises sinusoidal surface variations comprising multiple, alternately located lobes and troughs to move the second magnets closer to the first magnets when the magnets are temporarily in proximity to each other and further away from each other at other times.

10 14. The apparatus of any preceding claim, wherein the positioning element or cam comprises a central aperture to receive the second element therein.

15 15. The apparatus of any preceding claim, wherein the positioning element or cam is fixed below the second magnets such that undersides of the second magnets rest on the undulating or wave-like surface.

20 16. The apparatus of any preceding claim, wherein the second magnets are movably mounted by a flexible arm, a hinge or the like such that as the second element rotates relative to the first element due to the repulsive magnetic force between the first and second magnets, the second element 16 rotates relative to the positioning element or cam causing the second magnets to move up and down as they pass
25 over the undulating or wavelike surface of the positioning element or cam.

- 5 17. The apparatus of claim 15, wherein a periodicity of the lobes and troughs of the undulating or wavelike surface coincides with the number and arrangement of magnets such that the second magnets are moved closer to the first magnets when the magnets are temporarily in proximity to each other and further away from each other at other times.
- 10 18. The apparatus of any preceding claim, wherein an axis of rotation of the second element is variable to allow the second magnets to move closer to the first magnets when the magnets are temporarily in proximity to each other and further away from each other at other times.
- 15 19. The apparatus of any preceding claim, wherein the second element comprises one or more flexible or hinged arms or levers that pass over one or more raised areas via a bearing or brush to maximise the repulsive forces and minimises the attractive forces of the first and second magnets.
- 20 20. The apparatus of claim 19, wherein the second element comprises one or more pairs of flexible or hinged arms or levers whereby when one of the pair of arms or levers is not being caused to move by the repulsion of two magnets in proximity to each other, the other arm or lever of the same pair of arms or lever is being caused to move by
25 the repulsion of two other magnets in proximity to each other.

21. The apparatus of any preceding claim, comprising a pair of spaced apart second elements in the form of rotating discs comprising a plurality of second magnets, a central static disc between the two second elements, and at least one elongate first magnet extending between the two second elements at an angle through the central static disc such that opposite poles of the elongate first magnet are on opposite sides of the second elements.
22. The apparatus of any preceding claim, further comprising at least one converter in communication with the movable second element to convert kinetic energy of the second element into electrical energy.
23. A method of energy generation comprising using the apparatus of any preceding claim to generate electricity.
24. A method of energy generation comprising:
- mounting at least one first magnet to a first element;
 - mounting at least one second magnet to a second element,
- wherein the second element is movable with respect to the first element;
- orienting the at least one first magnet and the at least one second magnet such that common poles of the first and second magnets are temporarily in proximity to each other causing a repulsive magnetic force between the at least one first magnet and

at least one second magnet to cause relative motion between the first and second elements;

controlling a position and/or an orientation of the at least one first magnet and/or the at least one second magnet with at least one positioning element or cam comprising an undulating or wave-like surface; and

5

converting kinetic energy of the moving first and/or second element into electrical energy with at least one converter.

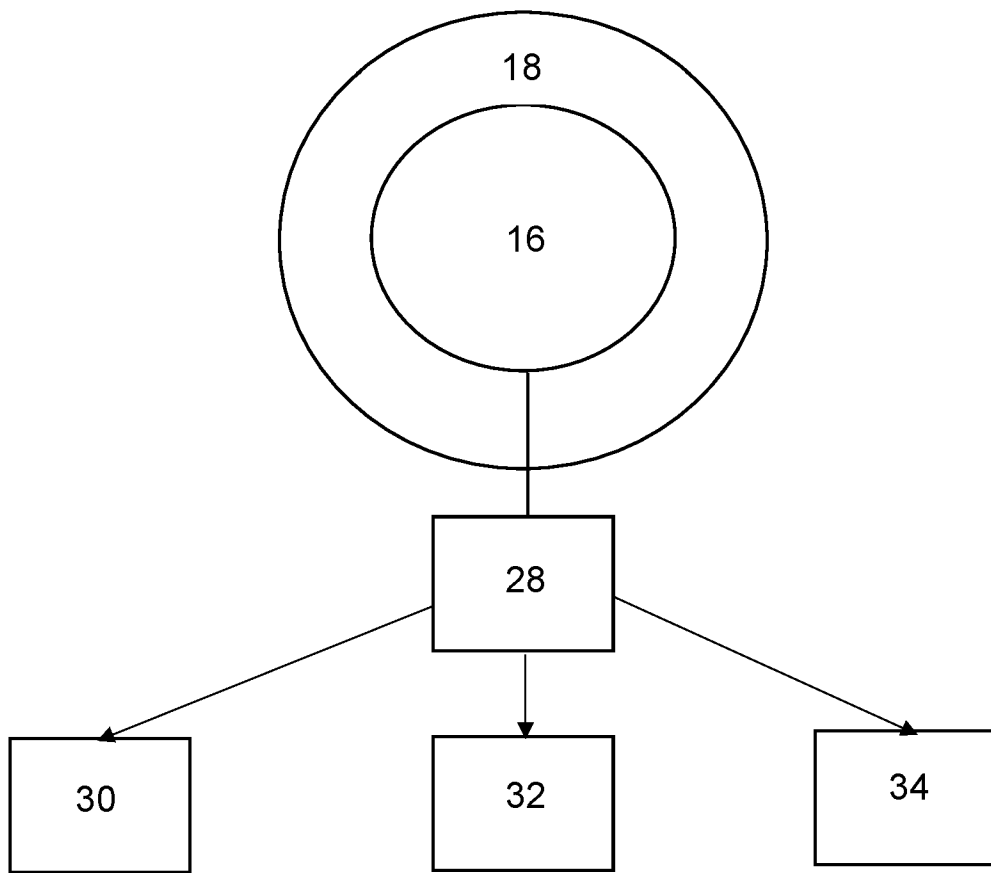

FIG 2

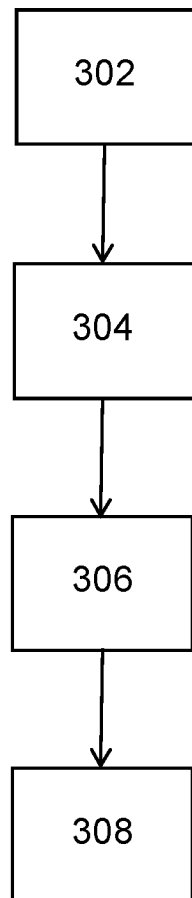

FIG 3

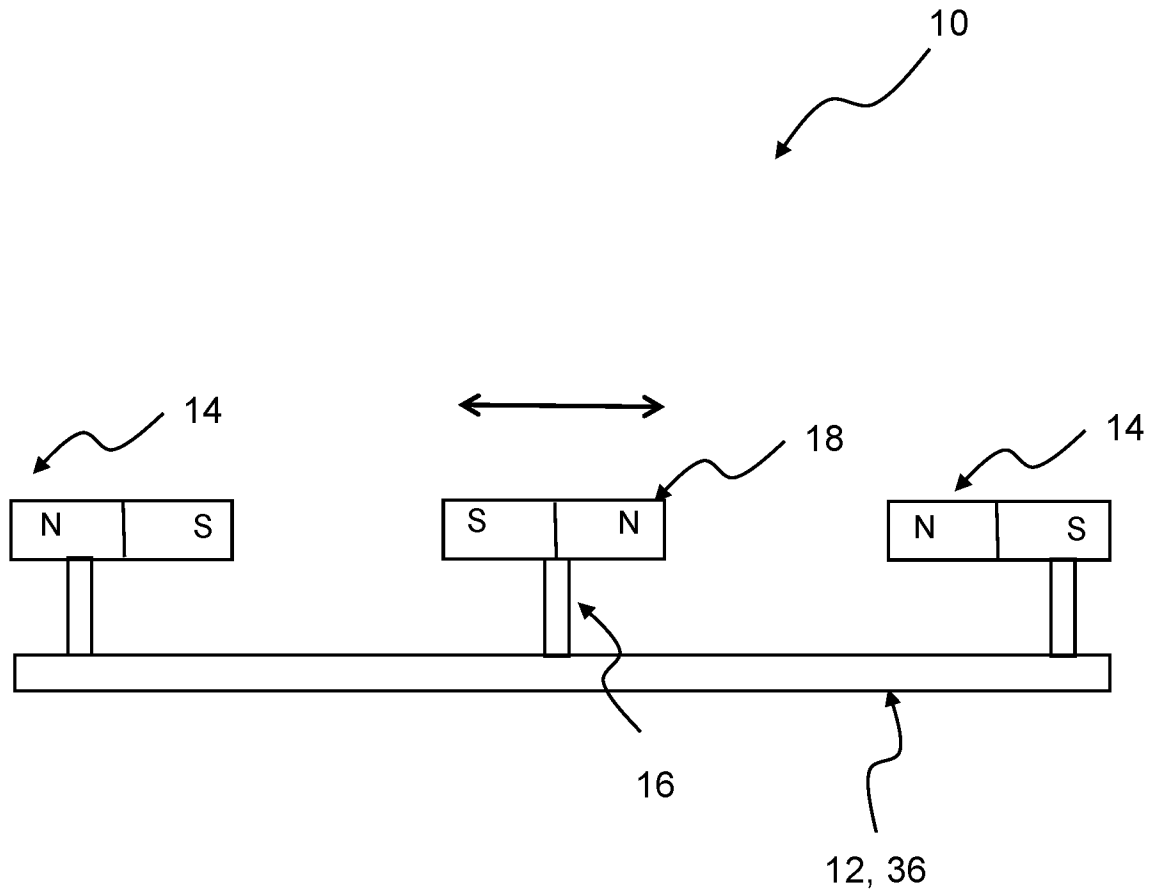

FIG 4

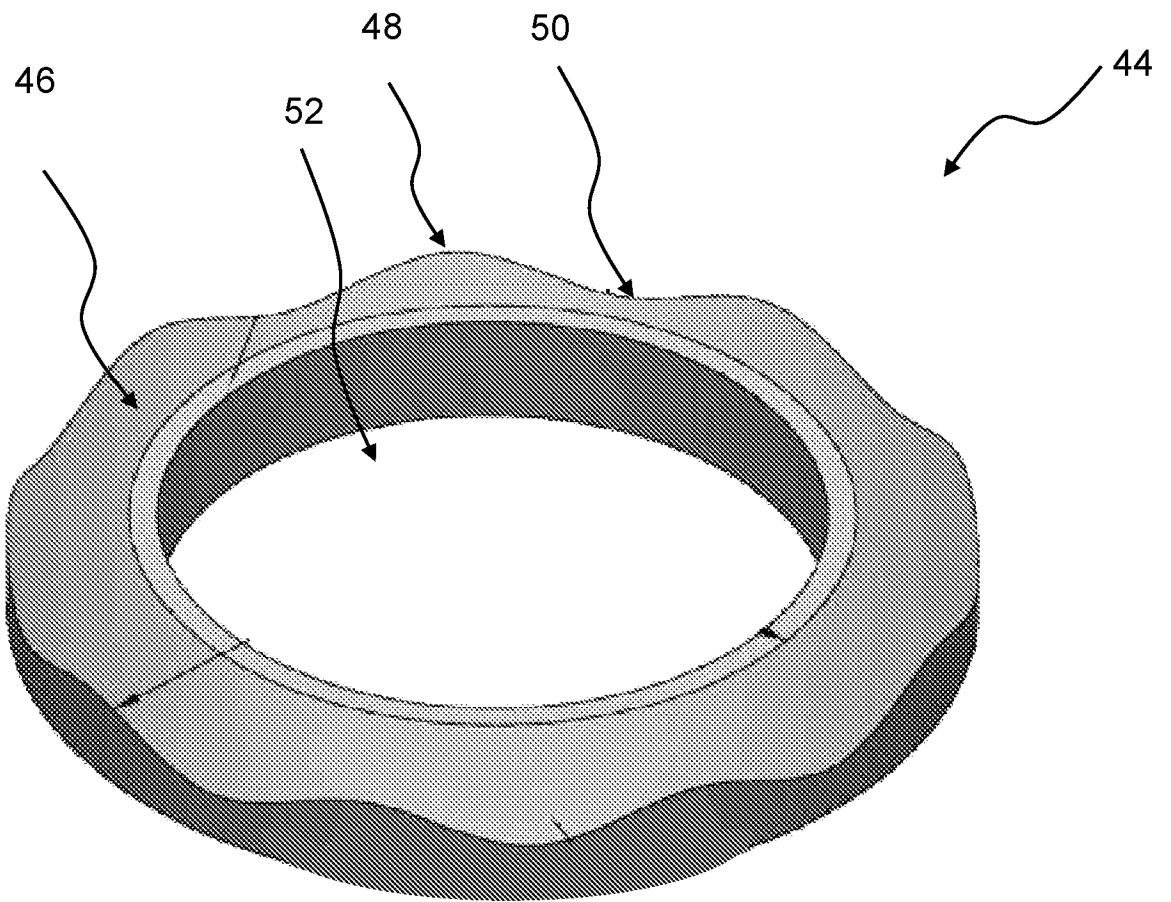

FIG 5

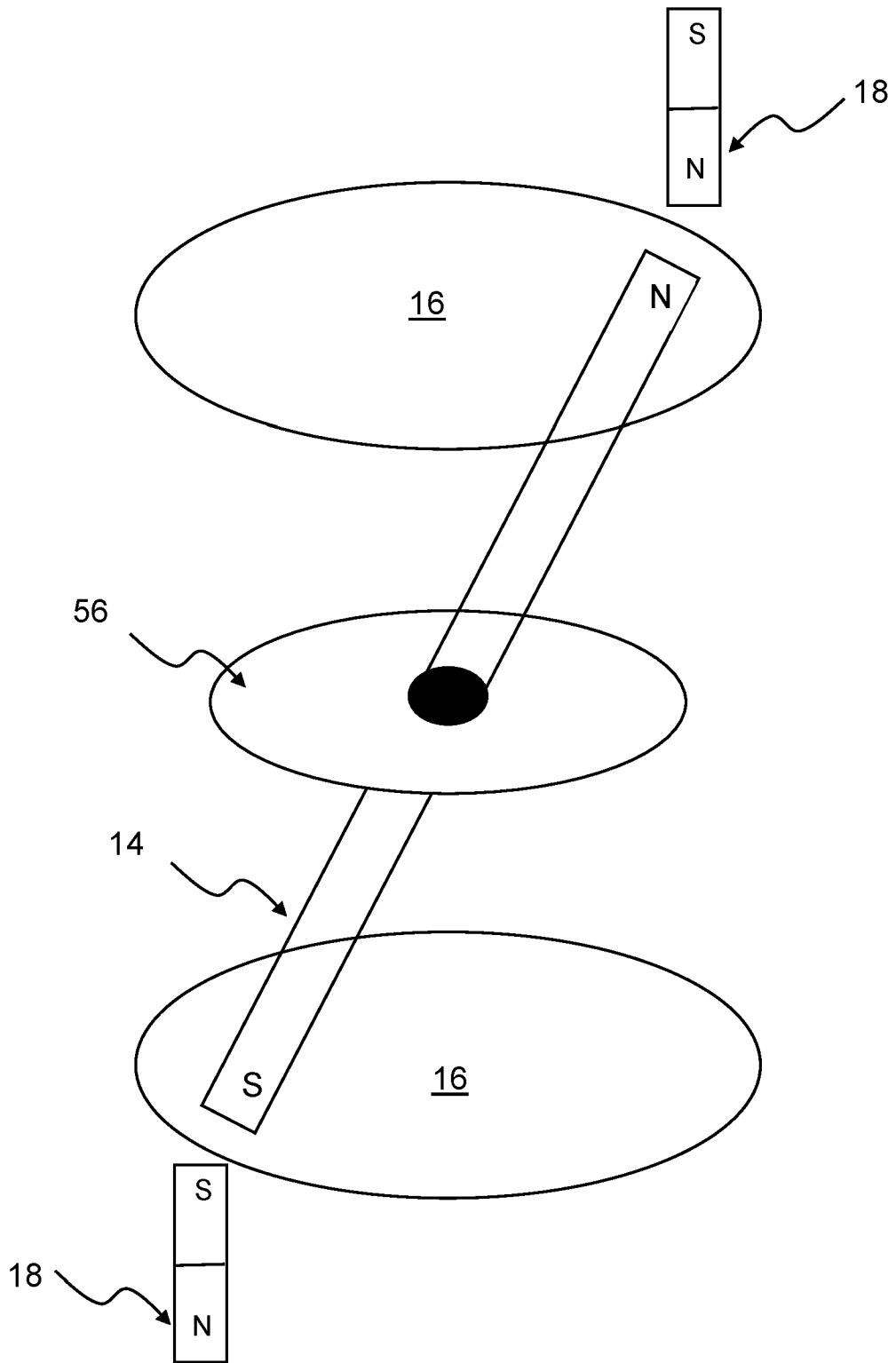

FIG 6

INTERNATIONAL SEARCH REPORT

International application No.
PCT/AU2019/051005

A. CLASSIFICATION OF SUBJECT MATTER

H02K 53/00 (2006.01) H02K 7/18 (2006.01) H02K 35/00 (2006.01) H02K 1/34 (2006.01) H02K 35/02 (2006.01)

According to International Patent Classification (IPC) or to both national classification and IPC

B. FIELDS SEARCHED

Minimum documentation searched (classification system followed by classification symbols)

Documentation searched other than minimum documentation to the extent that such documents are included in the fields searched

Electronic data base consulted during the international search (name of data base and, where practicable, search terms used)

Databases: PATENW, GOOGLE, GOOGLE PATENTS and ESPACENET.

IPC/CPC marks: H02K7/06, H02K53/00, H02K7/18, H02K35/02, H02K1/34, H02K7/1876, H02K57/00.

Keywords: Electric, generator, magnet, repulsive, force, motion, second, common, pole, linear, circumference, circular, equal, distance, converter, plate, cam, disk, wave, undulated and similar terms.

Espacenet, AUSPAT and IP Australia internal databases: Applicant/Inventor name search.

C. DOCUMENTS CONSIDERED TO BE RELEVANT

Category*	Citation of document, with indication, where appropriate, of the relevant passages	Relevant to claim No.
	Documents are listed in the continuation of Box C	

 Further documents are listed in the continuation of Box C See patent family annex

* Special categories of cited documents:		
"A" document defining the general state of the art which is not considered to be of particular relevance	"T" later document published after the international filing date or priority date and not in conflict with the application but cited to understand the principle or theory underlying the invention	
"D" document cited by the applicant in the international application	"X" document of particular relevance; the claimed invention cannot be considered novel or cannot be considered to involve an inventive step when the document is taken alone	
"E" earlier application or patent but published on or after the international filing date	"Y" document of particular relevance; the claimed invention cannot be considered to involve an inventive step when the document is combined with one or more other such documents, such combination being obvious to a person skilled in the art	
"L" document which may throw doubts on priority claim(s) or which is cited to establish the publication date of another citation or other special reason (as specified)	"&" document member of the same patent family	
"O" document referring to an oral disclosure, use, exhibition or other means		
"P" document published prior to the international filing date but later than the priority date claimed		

Date of the actual completion of the international search
21 November 2019Date of mailing of the international search report
21 November 2019

Name and mailing address of the ISA/AU

AUSTRALIAN PATENT OFFICE
PO BOX 200, WODEN ACT 2606, AUSTRALIA
Email address: pct@ipaustralia.gov.au

Authorised officer

Vinod Menon
AUSTRALIAN PATENT OFFICE
(ISO 9001 Quality Certified Service)
Telephone No. +61262832763

INTERNATIONAL SEARCH REPORT		International application No. PCT/AU2019/051005
C (Continuation). DOCUMENTS CONSIDERED TO BE RELEVANT		
Category*	Citation of document, with indication, where appropriate, of the relevant passages	Relevant to claim No.
Y A	US 8492936 B1 (WATERS et al.) 23 July 2013 Abstract, col 2 lines 24-67, col 3 line 19-col 5 line 65; fig 1-2 Whole document	1-15, 17, 22-24 16, 18-21
Y A	Thirumalairaj et al.; "Electric Power Generation by Using Magnetic Repulsive Force"; International Journal of Innovative Research in Science, Engineering and Technology; Vol. 6, Issue 11, November 2017 sec I-V; fig 1-3 Whole document	1-2, 4-11, 13-15, 17 and 22-24 3, 12, 16, 18-21
Y A	CN 107181387 A (ZHANG TIEZHENG) 19 September 2017 Whole document (especially figures and abstract) Whole document	1-2, 4-11, 13-15, 17 and 22-24 3, 12, 16, 18-21
Y A	US 5594289 A (MINATO KOHEI) 14 January 1997 Whole document (especially figures and abstract) Whole document	1-2, 4-11, 13-15, 17 and 22-24 3, 12, 16, 18-21
Y A	US 2017/0033645 A1 (ZAG TECHNOLOGIES (IRELAND) LIMITED) 02 February 2017 Paragraphs [0215]-[0228]; figs 32-39 Whole document	1-2, 4-11, 13-15, 17 and 22-24 3, 12, 16, 18-21
Y A	US 2007/0120432 A1 (VADEN et al.) 31 May 2007 paragraph [0037]; figs 5-7 Whole document	1-15, 17, 22-24 16, 18-21
Y A	WO 2017/205970 A1 (SINGH, ISWAR RAM) 07 December 2017 paragraph [0034], [0052]; fig 3, 8 Whole document	1-15, 17, 22-24 16, 18-21

INTERNATIONAL SEARCH REPORT

Information on patent family members

International application No.

PCT/AU2019/051005

This Annex lists known patent family members relating to the patent documents cited in the above-mentioned international search report. The Australian Patent Office is in no way liable for these particulars which are merely given for the purpose of information.

Patent Document/s Cited in Search Report		Patent Family Member/s	
Publication Number	Publication Date	Publication Number	Publication Date
US 8492936 B1	23 July 2013	US 8492936 B1	23 Jul 2013
CN 107181387 A	19 September 2017	CN 107181387 A	19 Sep 2017
US 5594289 A	14 January 1997	US 5594289 A	14 Jan 1997
		AU 7301494 A	30 Mar 1995
		AU 677854 B2	08 May 1997
		BG 99044 A	28 Jul 1995
		BG 61589 B1	30 Dec 1997
		BR 9403471 A	16 May 1995
		CA 2131336 A1	17 Mar 1995
		CN 1111413 A	08 Nov 1995
		EP 0647009 A1	05 Apr 1995
		EP 0647009 B1	10 Dec 1997
		FI 944260 A	17 Mar 1995
		FI 116104 B	15 Sep 2005
		HK 1001848 A1	10 Jul 1998
		HU T68078 A	29 May 1995
		HU 220522 B1	28 Mar 2002
		IL 110879 A	20 Nov 1997
		JP H0787725 A	31 Mar 1995
		JP 2968918 B2	02 Nov 1999
		KR 950007865 A	15 Apr 1995
		KR 100225263 B1	15 Oct 1999
		NO 305497 B1	07 Jun 1999
		NZ 264373 A	29 Jan 1997
		PL 305068 A1	20 Mar 1995
		PL 176647 B1	30 Jul 1999
		TW 303542 B	21 Apr 1997
US 2017/0033645 A1	02 February 2017	US 2017033645 A1	02 Feb 2017
		AU 2015243283 A1	24 Nov 2016
		CA 2978504 A1	15 Oct 2015
		EP 3329581 A2	06 Jun 2018
		JP 2017511118 A	13 Apr 2017

Due to data integration issues this family listing may not include 10 digit Australian applications filed since May 2001.

Form PCT/ISA/210 (Family Annex)(July 2019)

INTERNATIONAL SEARCH REPORT

Information on patent family members

International application No.

PCT/AU2019/051005

This Annex lists known patent family members relating to the patent documents cited in the above-mentioned international search report. The Australian Patent Office is in no way liable for these particulars which are merely given for the purpose of information.

Patent Document/s Cited in Search Report		Patent Family Member/s	
Publication Number	Publication Date	Publication Number	Publication Date
		WO 2015155249 A2	15 Oct 2015
US 2007/0120432 A1	31 May 2007	US 2007120432 A1	31 May 2007
WO 2017/205970 A1	07 December 2017	WO 2017205970 A1	07 Dec 2017
		CA 3025690 A1	07 Dec 2017
		US 2015311775 A1	29 Oct 2015
		US 9647522 B2	09 May 2017
		US 2016276916 A1	22 Sep 2016
		US 9853529 B2	26 Dec 2017
		WO 2015164941 A1	05 Nov 2015

End of Annex