

June 10, 1952

F. J. KEIFER, JR

2,599,839

REAR SIGHT ADJUSTING DEVICE FOR PISTOLS

Filed Oct. 26, 1949

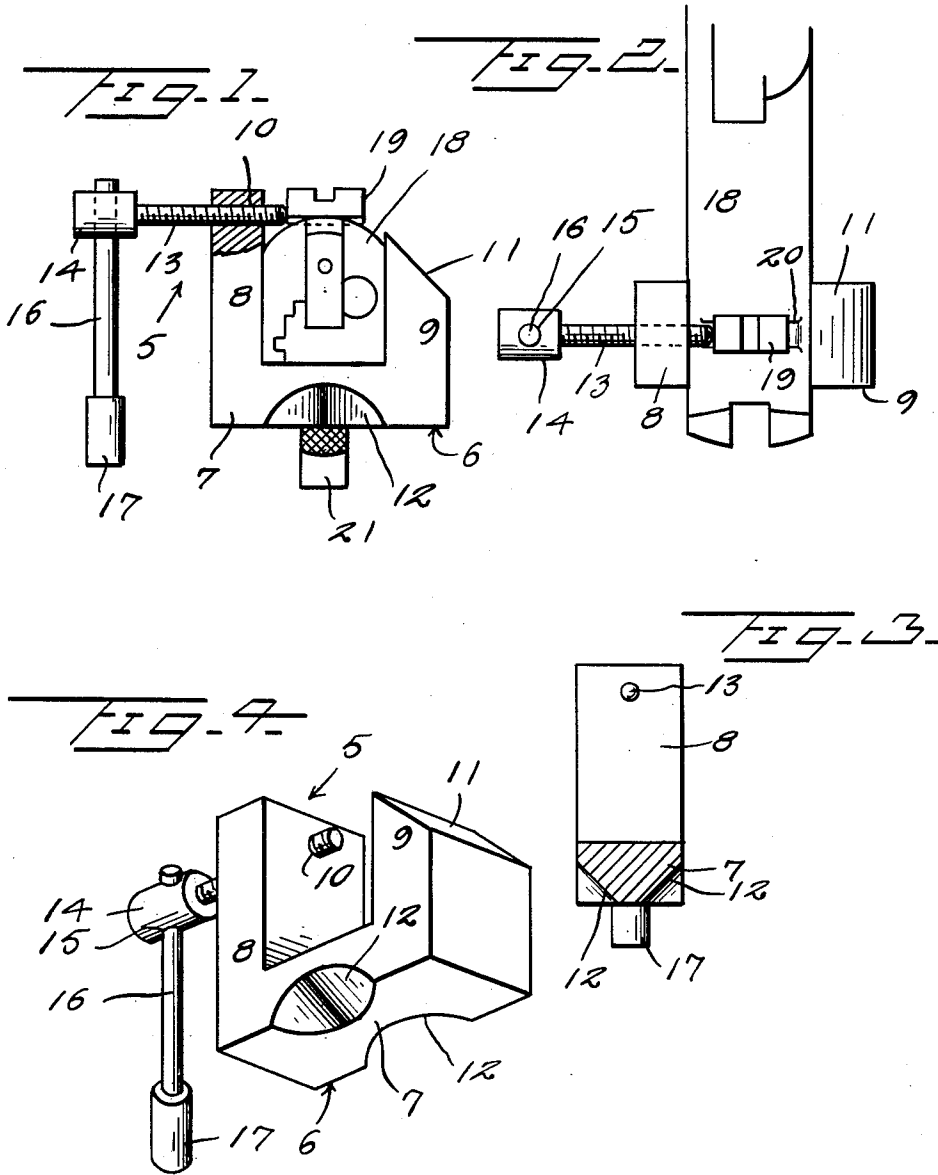

Inventor  
*Frederick J. Keifer, Jr.*

By *John N. Randolph*

1412

~~1419~~

Attorney

P2

Patented June 10, 1952

2,599,839

## UNITED STATES PATENT OFFICE

2,599,839

REAR SIGHT ADJUSTING DEVICE FOR  
PISTOLS

Frederick J. Keifer, Jr., Fort Benning, Ga.

Application October 26, 1949, Serial No. 123,567

4 Claims. (Cl. 33-59)

1

This invention relates to a vise type device capable of being quickly and easily applied to a pistol or other firearms having a rear sight which is not provided with adjusting means for displacing the rear sight laterally of the barrel of the piece for making adjustments for windage or for correcting the sight of a pistol or revolver which is firing to the left or to the right of a target.

Most pistols and revolvers are provided with no means for laterally adjusting the rear sight and any movement of said sight transverse to the barrel may only be accomplished by tapping the sight with a hammer or other impact tool so that the extent of movement of the sight cannot be accurately determined and will vary depending upon how tightly the sight is fitted and how hard and how many times it is struck with the impact tool. Accordingly, it is the primary object of the present invention to provide a device of extremely simple construction which may be quickly and easily applied to or removed from a pistol or revolver and by the use of which the rear sight may be accurately displaced laterally of the barrel of the piece by manual manipulation thereof for making any necessary corrections for windage or for inaccurate firing of the piece to either side of a target.

More particularly, it is an object of the present invention to provide a sight adjusting device primarily adapted for use on a Colt pistol having a reciprocally mounted slide which carries the rear sight and comprises a device which may be readily applied to said slide, when retracted rearwardly, for engaging and displacing the rear sight laterally in either direction with respect to the slide.

Various other objects and advantages of the invention will hereinafter become more fully apparent from the following description of the drawing, illustrating a preferred embodiment thereof, and wherein:

Figure 1 is a side elevational view partly in section, of the sight adjusting device shown applied to the slide of a pistol and positioned for displacing the rear sight from left to right of the slide looking from the rear end of the slide;

Figure 2 is a top plan view of the sight adjusting device in an applied position;

Figure 3 is a vertical sectional view taken intermediate of the ends of the frame of the sight adjusting device and looking from right to left as seen in Figure 1 or toward the feed screw, and

Figure 4 is a perspective view of the sight adjusting device shown removed.

2

Referring more specifically to the drawing, the vise type sight adjusting device in its entirety is designated generally 5 and includes a substantially U-shaped frame, designated generally 6 which is formed of metal and of sufficient thickness to be substantially rigid and which includes an intermediate or bottom portion 7 and a pair of upstanding legs or side members 8 and 9 which rise from the ends of the intermediate portion 7 and are formed integral therewith and which are disposed substantially parallel to one another. The leg or side 8 extends to above the level of the upper end of the leg or side 9 and has a threaded opening 10 extending transversely there-through adjacent its upper end and above the level of the upper end of the side 9. The upper end of the side 9 may be bevelled on its outer side, as seen at 11. The intermediate portion 7 of the frame 6 is provided intermediate of its ends with complementary recesses 12 formed in its opposite sides and bottom surface, as best illustrated in Figure 4, for a purpose which will hereinafter become apparent.

A feed screw 13 extends threadedly through the threaded opening 10 and has a head 14 at its outer end and which is disposed outwardly of the frame 6. The head 14 has a bore 15 extending transversely therethrough for receiving one end of an elongated handle 16 which may be loosely or rigidly secured in said bore 15 and which has an enlargement or grip portion 17 at its opposite end.

To utilize the sight adjusting device 5, as for example with a pistol having a reciprocating slide such as is provided on Colt automatic pistols of the type used by the Armed Forces of the United States, the slide of the pistol is moved rearwardly and latched in a conventional manner in a retracted position. Figures 1 and 2 illustrate such a pistol slide, designated generally 18 and on which is carried a conventional rear sight 19 which is mounted in a slot 20 which is disposed transversely of the upper surface of the slide 18. To displace said rear sight 19 from left to right, looking from the rear toward the front of the slide 18, the frame 6 is applied to the rear end of the slide 18 from beneath and so that the side members 8 and 9 will engage opposite sides of the rear portion of the slide and substantially in transverse alignment with the rear sight 19. In moving the slide 18 rearwardly the pistol hammer 21 is swung downwardly and into a cocked position and the recesses 12 are accordingly provided for accommodating a portion of the hammer 21 when the frame 6 is applied as illustrated in Figure 1. A recess 12 is

3

provided in each side of the frame 6 so that the other recess will function to accommodate the hammer when the frame 6 is reversed with respect to the slide, as will hereinafter be described. It will be noted that when the frame 6 is applied as illustrated in Figure 1 that the feed screw 13 will be located at substantially the level of the rear sight 19 whereas the frame side 9 will terminate below the level of said rear sight so as not to interfere with its lateral displacement in a direction toward said frame side 9. After the frame 6 has been thus applied, and as illustrated in Figure 1, and with the feed screw 13 fully retracted so that its inner end does not protrude from the inner surface of the side 8, the feed screw 13 is rotated by manually swinging the handle 16 in a circular motion for advancing said feed screw inwardly of the frame and into engagement with one end of the rear sight 19, as illustrated in Figures 1 and 2. By further turning the feed screw 13, as previously described, for advancing it inwardly of the frame 6, the frame side 9 will be held in tight engagement with the side of the slide 18 engaged thereby and will form an abutment therewith so that the rear sight 19 will be displaced laterally of the slide 18 by the feed screw 13 and from left to right of Figure 1 or toward the frame side 9. The threads of the screw 13 of the bore 10 may be of such a pitch that one complete revolution of the screw 13 will move the rear sight 19 laterally of the slide 18 a distance so that a bullet fired from the piece will be displaced laterally four inches on a target at a range of fifty yards, for example, or such pitch of the threads can be varied so that one revolution of the feed screw 13 will make any other desired variation in the travel of a bullet in any prescribed range.

Obviously, the sight adjusting device 5 may be utilized in the same manner as previously described for displacing the rear sight 19 in the opposite direction merely by applying the frame 6 so that the sides 8 and 9 will engage opposite sides of the slide 18 to the sides thereof shown engaged by said portions 8 and 9 in Figures 1 and 2 and in which case the feed screw 13 will engage the opposite end of the rear sight 19 for displacing it in the opposite direction. When the frame 6 is thus reversed the other recess 12 will then accommodate a portion of the hammer 21.

Various modifications and changes are contemplated and may obviously be resorted to, without departing from the spirit or scope of the invention as hereinafter defined by the appended claims.

I claim as my invention:

1. A rear sight adjusting device comprising a U-shaped frame having side members provided with adjacent parallel surfaces adapted to engage opposite sides of a firearm and in transverse alignment with the rear sight thereof, and a feed screw extending through one of said side members inwardly of the frame and having an inner end disposed to engage one end of the rear sight for displacing the rear sight laterally of the firearm and toward said other side member when the feed screw is turned in a direction for advancing it inwardly of the frame.

2. A sight adjusting device as in claim 1, said frame having an intermediate portion adapted to engage the underside of the firearm, said side

4

members extending upwardly from the ends of said intermediate portion, and the side member carrying said feed screw extending to above the level of the other side member for supporting said feed screw above the level of the upper end of said last mentioned side member.

3. A rear sight adjusting device for pistols having reciprocating slides comprising a substantially U-shaped frame including an intermediate portion and spaced parallel upwardly extending side members, said frame being adapted to engage the pistol slide when in a retracted position with said intermediate portion beneath the slide and with the side members thereof extending upwardly therefrom and each engaging a side wall of the slide, one of said side members extending to above the level of the other side member and to above the level of the upper surface of the slide, when the frame is applied thereto, and having a threaded bore extending transversely therethrough and disposed above the level of the upper end of said other side member, a feed screw threadedly engaging said bore and extending inwardly of the frame for engaging one end of a rear sight supported by the slide, said feed screw being adapted to be manually actuated and advanced inwardly of the frame for displacing the rear sight transversely of the slide and toward the other side member of the frame.

4. The combination with a pistol having a reciprocating slide and a transversely adjustable sight mounted thereon, of a sight adjusting device comprising a U-shaped frame having an intermediate portion and spaced parallel extending side members defining parallel opposed walls, said frame engaging the retracted slide with the intermediate portion beneath the slide and the side members extending upwardly from the intermediate portion and straddling the slide, the opposed walls of the side members engaging the side walls of the slide, one of the side members extending to above the level of the other side member and to above the level of the upper surface of the slide, when the frame is applied thereto, and having a threaded bore extending transversely therethrough above the level of the upper end of said other side member, a feed screw threadedly engaging said bore and extending inwardly of the frame and engaging one end of the sight, said feed screw being advanced inwardly of the frame by rotation thereof in one direction for displacing the sight transversely of the slide toward the other side member of the frame.

FREDERICK J. KEIFER, JR.

#### REFERENCES CITED

The following references are of record in the file of this patent:

#### UNITED STATES PATENTS

Number	Name	Date
747,224	Rieffel	Dec. 15, 1903
800,195	Windridge	Sept. 26, 1905
1,425,201	Hetherington	Aug. 8, 1922
1,887,437	Schotthoefer	Nov. 8, 1932

#### FOREIGN PATENTS

Number	Country	Date
81,276	Sweden	1934