

- [54] **LITHOGRAPHY**
- [75] Inventor: **John Kenneth Houston**, Epping, England
- [73] Assignee: **The Rank Organization Limited**, London, England
- [22] Filed: **Aug. 12, 1971**
- [21] Appl. No.: **171,286**

3,601,018	8/1971	Lange .....	95/1 R
3,548,713	12/1970	Melrose .....	95/1 R
3,582,208	6/1971	Idler .....	355/132
3,559,546	2/1971	McKee .....	95/1 R
3,610,752	10/1971	Wilson .....	355/125 X

*Primary Examiner*—Joseph F. Peters, Jr.  
*Assistant Examiner*—Alan Mathews  
*Attorney, Agent, or Firm*—Brisebois & Kruger

- [30] **Foreign Application Priority Data**
- Aug. 12, 1970 Great Britain..... 38809/70
- Mar. 19, 1971 Great Britain..... 7288/71
- [52] **U.S. Cl.**..... **355/78, 355/132, 96/36.2**
- [51] **Int. Cl.**..... **G03b 27/02**
- [58] **Field of Search**..... 355/78, 77, 132, 133, 125, 355/84; 95/1 R; 95/36.2, 35; 313/92 B

- [56] **References Cited**
- UNITED STATES PATENTS**
- 3,615,449 10/1971 Greenway..... 96/35

[57] **ABSTRACT**

This invention is concerned with shadow or contact printing as employed, for example in the photo-etching of substrates. An extended source of printing radiation, either in the form of an effectively annular fixed source or an orbiting source, is used to illuminate the mask under conditions of transitional Fresnel-Fraunhofer diffraction, the effective illumination condition of the mask during an exposure causing diffraction patterns which tend to cancel each other, producing a sharply defined shadow of the mask.

**33 Claims, 10 Drawing Figures**

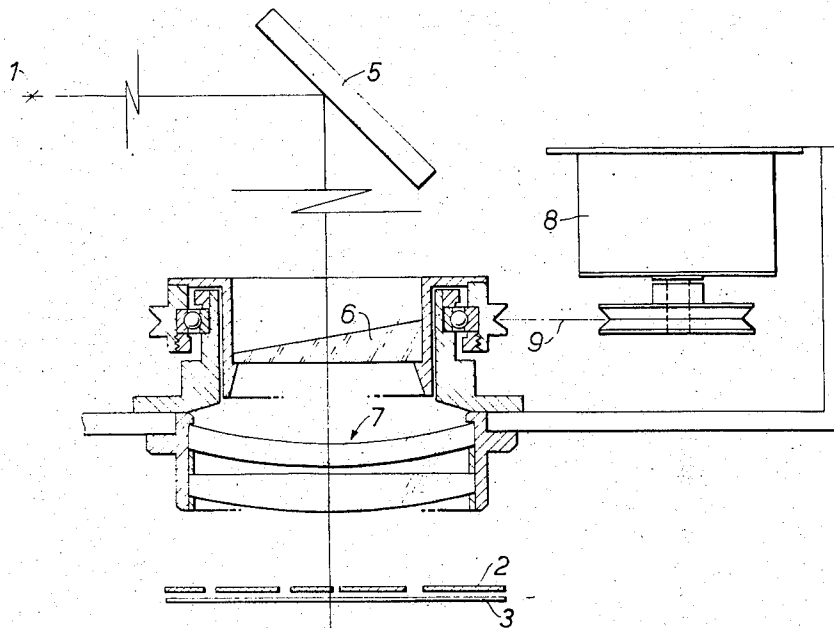

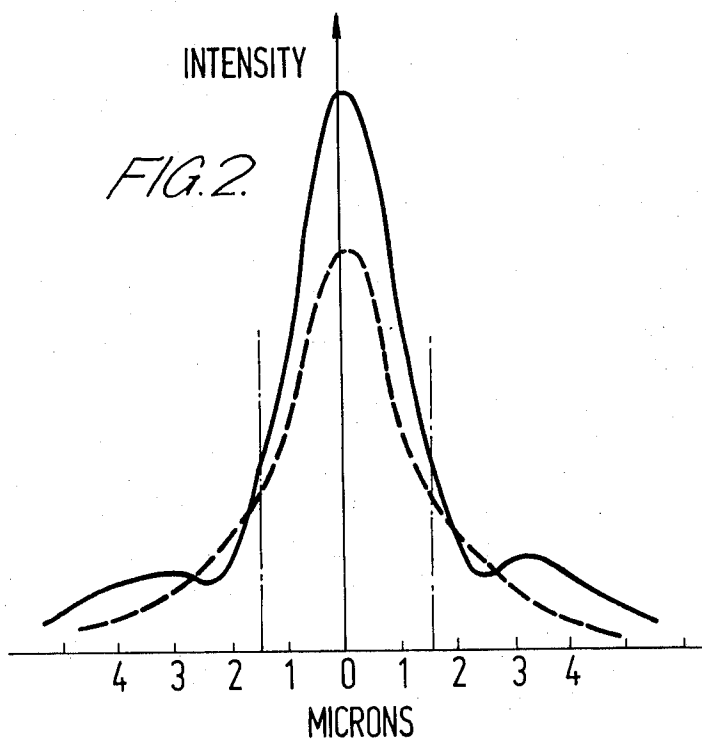
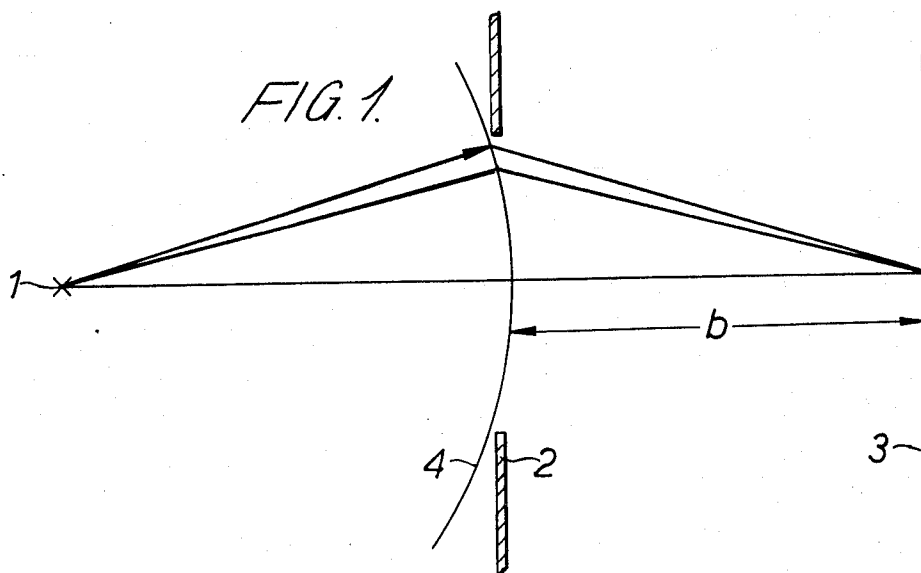

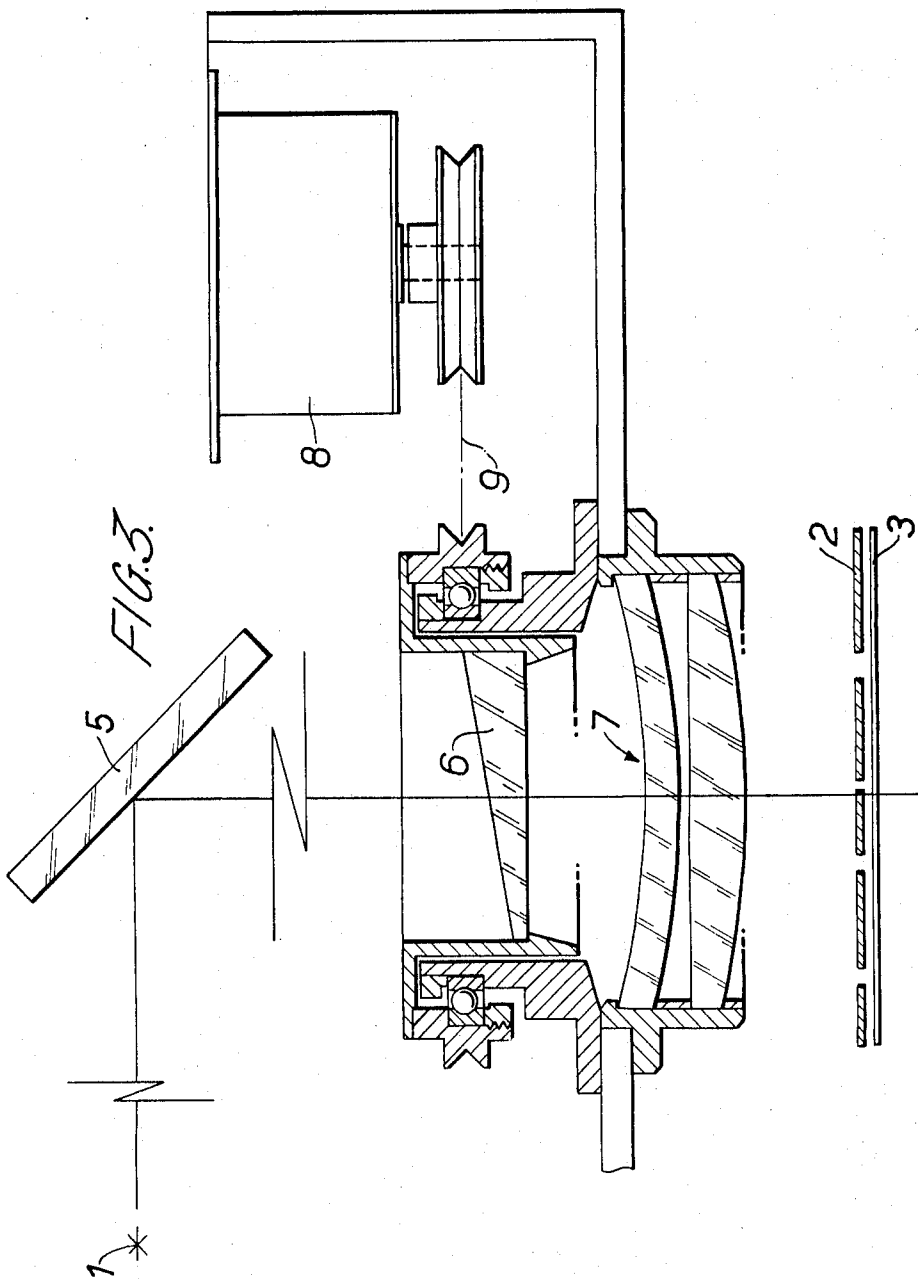

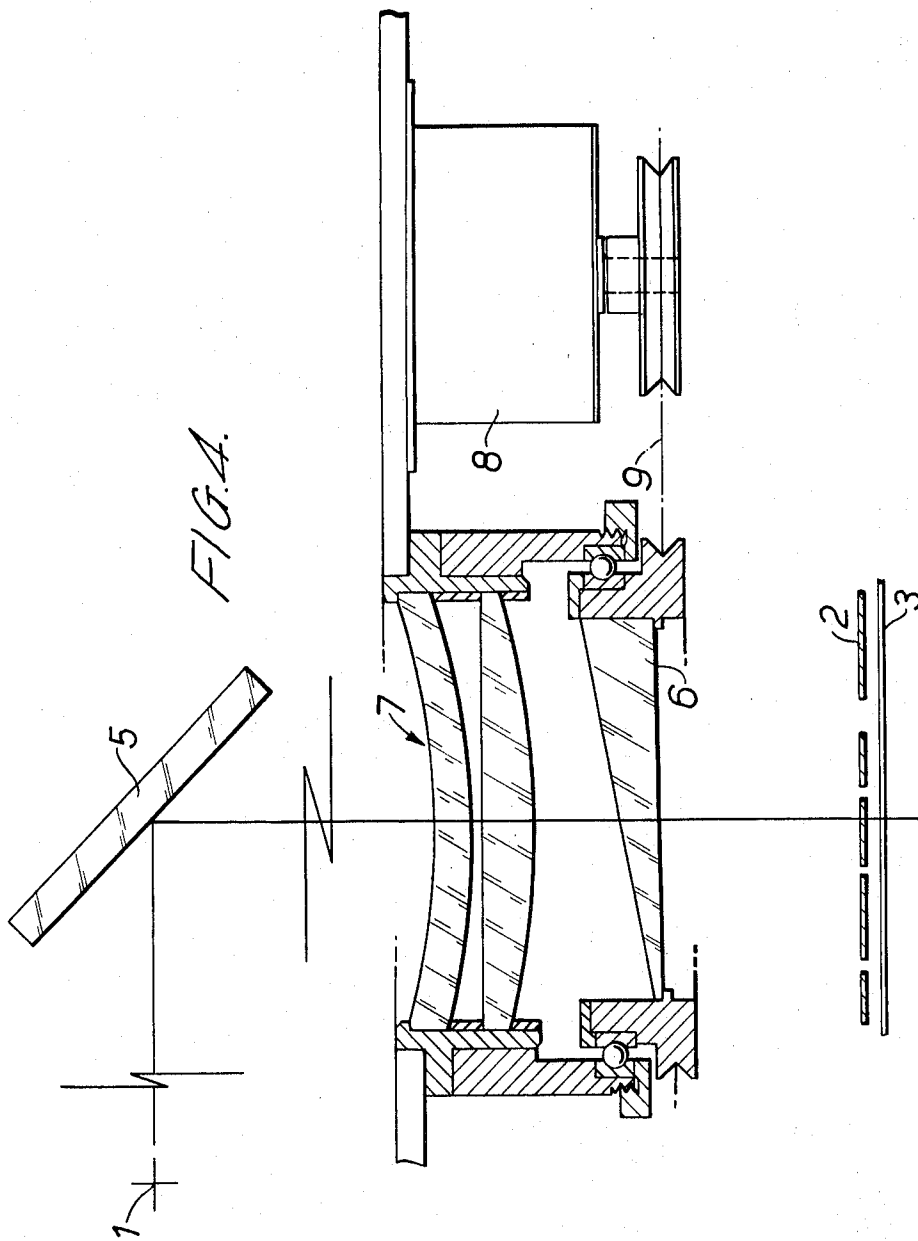

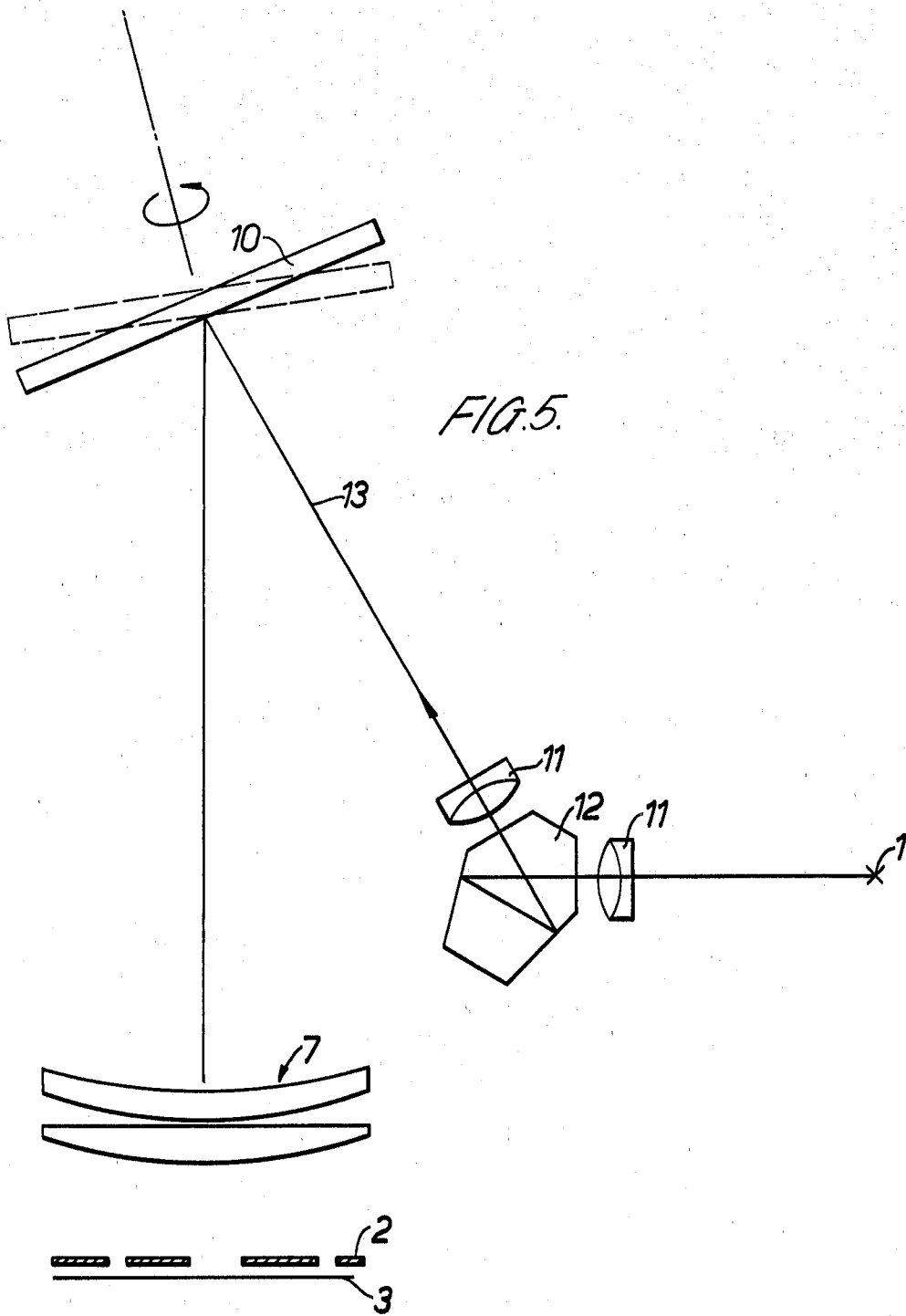
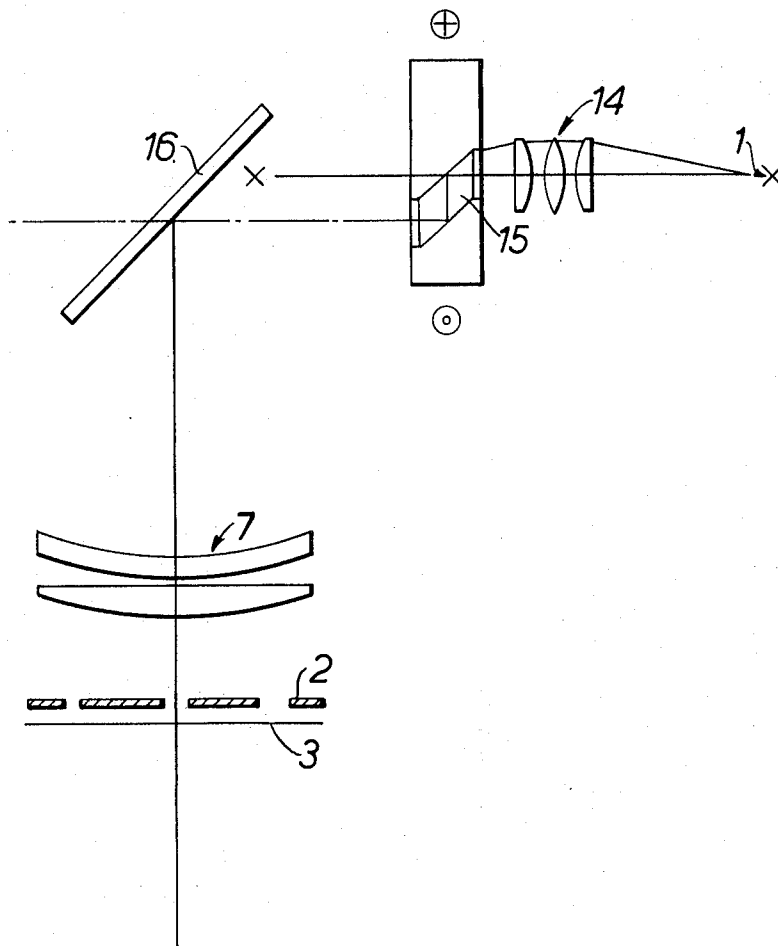
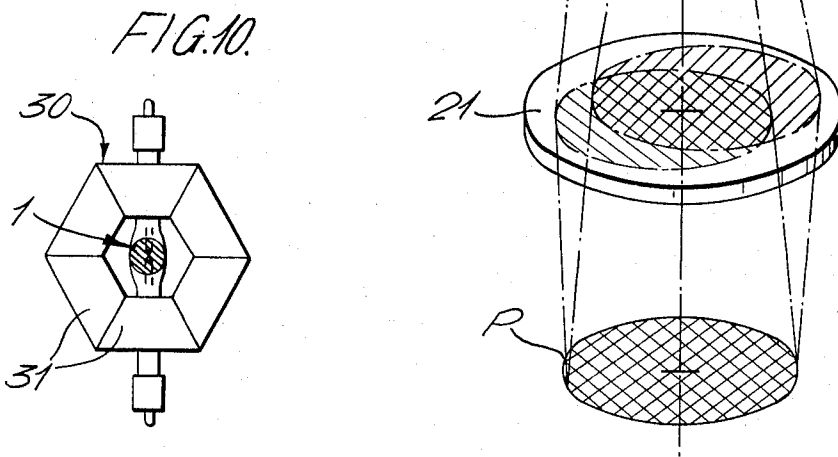
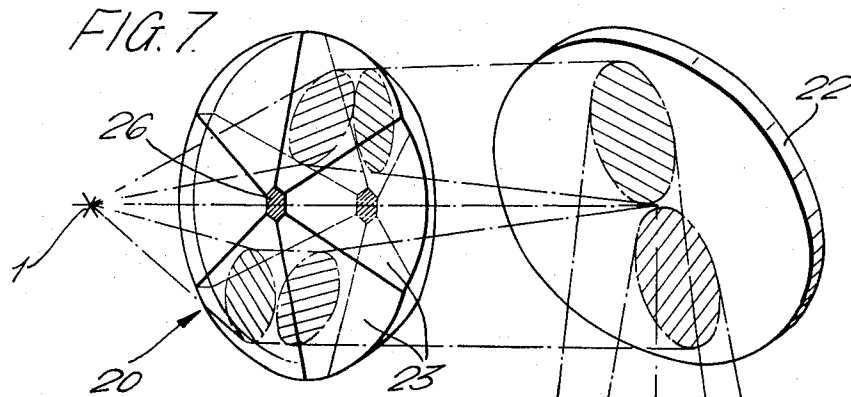
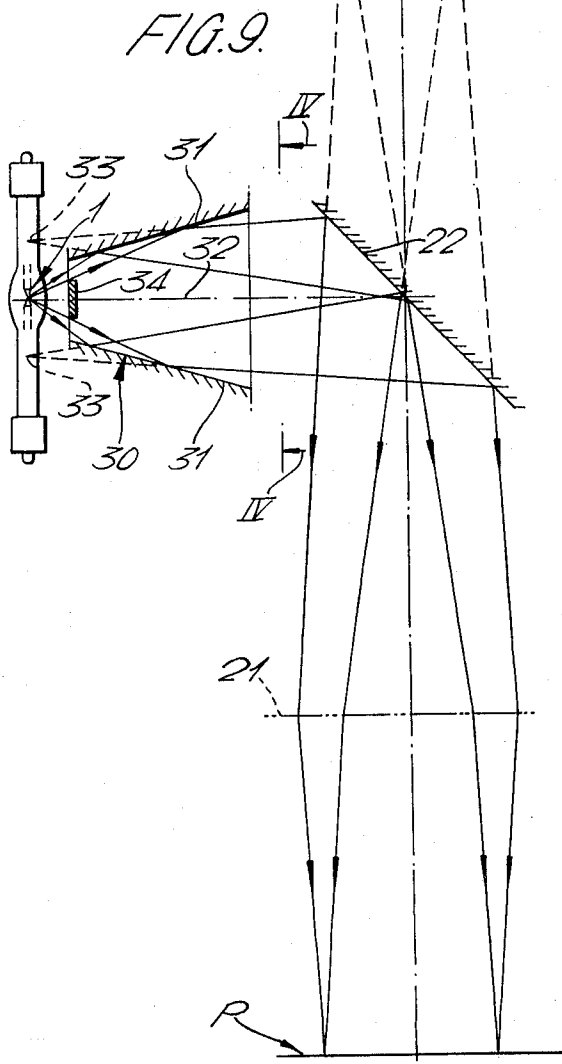
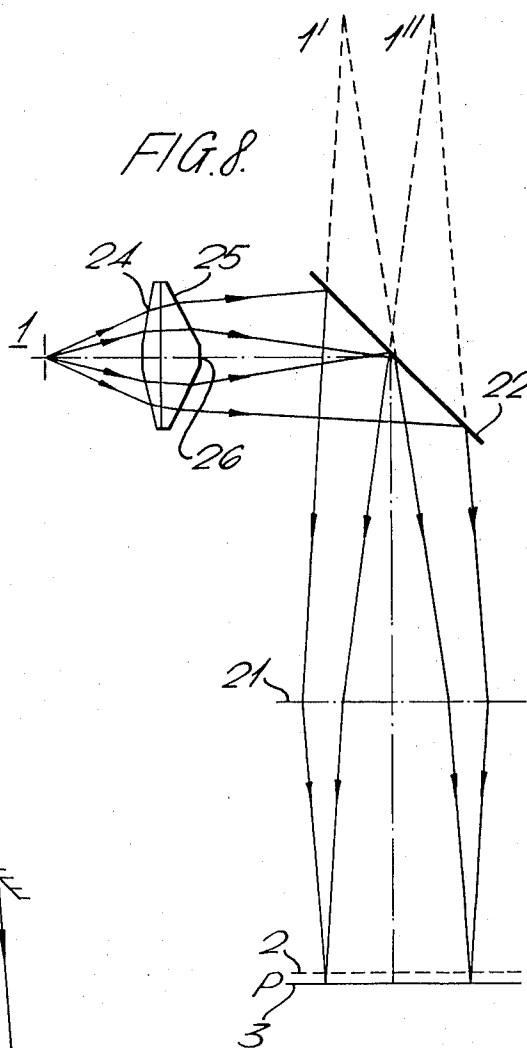

FIG. 6.







## LITHOGRAPHY

This invention relates to micro-circuit printing techniques, and in particular to the so called "shadow" and "contact" methods of printing micro-circuit components photolithographically on to prepared substrates, usually of semi-conductor material.

In printing a micro-circuit image photolithographically on to a semi-conductor substrate such as a silicon slice by the shadow technique, a mask having a pattern of image-forming surfaces is located in the path of the printing radiation incident on a photosensitive surface formed on the substrate. It is important that the imprinted image be a well-defined and geometrically accurate reproduction of the image-forming surface of the mask, that is, that a sharply defined shadow of these surfaces be formed on the substrate surface.

In the contact printing method the mask is placed directly on the substrate to be printed, while in the shadow printing or out-of-contact printing method the mask is arranged close to but spaced from the substrate. However, in the contact printing method literal contact is not in practice made between the illuminated image-forming surface of the mask and the underlying substrate, so that both methods may be regarded as shadow printing methods in effect. A problem which militates against the formation of a clearly defined image on the substrate, which is necessary for accurate circuit printing, is that of diffraction at the edges of the mask features. The effect of the diffraction pattern produced on the substrate in the region of the shadow image of the mask can be reduced to some extent by control of the exposure of the treated substrate to the printing radiation. However, it is not possible by regulation of exposure alone to eliminate entirely the troublesome diffraction effects.

It has now been found that the effects of diffraction in shadow printing can be considerably reduced by means of a specific choice of illuminating source geometry, with the source suitably positioned in relation to the mask and the substrate.

The present invention in one aspect accordingly provides illumination means for use in shadow or contact printing, comprising a source of finite predetermined area having an effective brightness distribution affording a central dark area surrounded by a bright zone, the said brightness distribution being such that when a mask is illuminated by the source under conditions of transitional Fresnel-Fraunhofer diffraction as herein defined, the effective illumination condition produced by the light incident on any given part of the mask from different parts of the source produces diffraction patterns which tend to cancel each other over part of said patterns.

The term "transitional Fresnel-Fraunhofer diffraction" is defined for the purpose of this specification as that type in diffraction which is observable at a distance from a coherently illuminated line or slit of the same order as the line or slit width. Under these conditions the Fresnel fringes observable on a screen located at said distance and parallel to the line or slit overlap the boundaries of the geometrical image of the line or slit on the screen. Reference in this connection is made to "Introduction to Theoretical Physics" J. C. Slater and H. Frank, McGraw-Hill Book Co., 1937, pages 317 - 322.

By using illumination means in accordance with the invention it is possible to improve the definition obtainable with shadow printing and contact printing, without recourse to expensive projection lenses. The invention represents a significant departure from conventional illumination means for shadow printing, in which stress has been laid upon the requirement for accurately collimating the printing radiation beam to a condition of minimal non-divergence:

in the present invention the illuminating radiation provided by the source comprises a set of diverging waves.

The source may have an annular shape. In one embodiment of the invention the effective brightness distribution of the source comprises a number of bright zones distributed regularly in an annular pattern around the central dark zone.

Thus the source may comprise in combination a single point source and a fixed multiple prism comprising a number of prism elements arranged in an annular array such that light from the point source passes through the said prism elements to provide the same number of component beams, and a collimator through which said component beams pass to produce the said effective illumination condition in a printing plane.

The prism conveniently may comprise a number of identical adjacent prism elements of sector shape, each prism element tapering a thickness from a maximum at its vertex to a minimum at its outer edge. The outer edges of the prism elements may lie on a common circle. Each prism element is preferably truncated at its vertex so that the multiple prism has a central portion with plane parallel outer faces.

The two outer faces of each prism element are preferably both inclined to the radial plane of the multiple prism. These outer faces are preferably coated for optimum transmission in a specific band of wavelengths.

The multiple prism is preferably formed in two parts, each ground to provide respective parts of the prism elements, and each having a plane radial face, the two parts being cemented together back-to-back at said plane faces with the parts of the prism elements in register with each other.

In practice best results are obtained when the prism comprises six or more identical prism elements.

In another practical embodiment of the invention the illumination means comprise a single point source and a fixed composite reflector having a number of reflector elements arranged in an annular array such that light from the point source forms, by reflection in said reflector elements, the same number of component beams, and a collimator through which said component beams pass to produce the said illumination condition in a printing plane.

Preferably the said reflector elements are arranged so that they form virtual images of the said point of light source in a common plane containing said point source. A stop may be arranged centrally of the annular array of reflector elements to prevent the direct passage of light through said array without reflection by the reflector elements.

The component beams emerging from the multiple prism or from the composite reflector as the case may be are preferably deflected through substantially 90° by a reflecting element before passing through the collimator.

As an alternative to providing a fixed annular or substantially annular source the source may be moved orbitally around a circular path to provide an annular effective brightness distribution over the period of the exposure. Preferably, however, the source provides a collimated light beam which is caused to scan a conical or cylindrical surface cyclically by rotation of a reflecting or refracting element mounted in the path of the said collimated light beam.

The rotatable element may comprise a rotatable wedge prism mounted in the path of said light beam between the source and a collimator, the resulting collimated beam performing a conical scan upon rotation of the wedge prism. Alternatively the rotatable wedge prism may be mounted in the path of the said light beam with a collimator interposed between the prism and the source, so that the collimated beam upon emerging from the prism performs a conical scan upon rotation of the prism.

In a further alternative embodiment of the invention the rotatable element comprises a plane mirror mounted for rotation about an axis which is inclined to the normal to the reflecting surface of the mirror, the mirror being positioned in the said light path between the light source and a collimator, so that the resulting collimated beam performs a conical scan upon rotation of the mirror.

The rotatable element may alternatively comprise a rhomb prism mounted for rotation about an axis perpendicular to two plane parallel faces through which the said light beam passes.

As stated above, the illumination means according to the invention has particular application to shadow printing, but it will be appreciated that the invention is also applicable to contact printing referred to above and more generally in other contexts where some degree of compensation for Fresnel-Fraunhofer diffraction is required.

The invention also provides according to another aspect a method of shadow printing in which radiation from an extended source is directed through a shadow-mask on to a radiation-sensitive substrate to be printed, the effective brightness distribution of the source affording a central dark area surrounded by a bright zone, and the mask and substrate being centrally positioned relative to said dark area, so that fringes produced on the substrate by transitional Fresnel-Fraunhofer diffraction, as herein defined, of light incident on any given part of the mask from different parts of the source substantially cancel each other over a part of the substrate area.

In a preferred embodiment of the invention the source, which preferably comprises illumination means as previously defined, emits radiation having a wavelength of substantially 0.4 microns, the mask being spaced from the substrate by substantially 9 microns. Under these conditions the range of the shadow diffraction pattern imaged on the substrate which is effectively smoothed — that is, compensated for defraction fringes — extends over a range of 3 to 6 microns on the substrate.

As stated previously, the source is preferably arranged so that its effective brightness distribution is annular, for example, in the form of a square annulus or, preferably, a circular annulus.

Where the source has a circular annular form, or the source or its radiation is scanned over an annular path,

it is preferably arranged that the source illuminates any point on the mask with radiation which lies between two cones having a common apex at said point and a common axis normal to the plane of the mask. The said two cones in the preferred embodiment of the invention referred to above, using printing radiation of wavelength 0.4 microns, preferably have half-angles of  $3\frac{1}{4}^\circ$  and  $4\frac{3}{4}^\circ$  respectively.

The invention will now be described, merely by way of example, with reference to the accompanying drawings, in which:

FIG. 1 shows an elementary shadow printing arrangement, illustrating diagrammatically the Fresnel diffraction of a spherical wavefront impinging upon a rectangular aperture in a mask;

FIG. 2 is a diagrammatic representation of the resulting diffraction pattern produced upon a substrate spaced a distance of 12 microns from a slit in the mask of FIG. 1 having a width of 3 microns, together with the diffraction pattern produced by illuminating means in accordance with the invention;

FIGS. 3 to 6 are diagrams illustrating the optical arrangement of different embodiments of illumination means in accordance with the invention utilising rotary optical elements to produce diffraction compensation in shadow printing;

FIG. 7 is an explanatory diagrammatic perspective view illustrating illumination means according to one embodiment of the invention utilising fixed optical elements;

FIG. 8 is a diagrammatic side elevation of the illumination means shown in FIG. 7, illustrating typical ray paths;

FIG. 9 is a diagrammatic side elevation of illumination means according to an alternative embodiment of the invention, illustrating typical ray paths, and

FIG. 10 is an end elevation of part of the illumination means of FIG. 9, viewed on line X—X of FIG. 9.

Referring first to FIG. 1, there is shown purely diagrammatically an elementary shadow printing arrangement comprising a point source 1, an apertured mask 2 and a substrate 3 having a photosensitive surface coating upon which radiation emitted from the source 1 impinges after passing through the apertured mask 2.

FIG. 1 shows a spherical wavefront 4 originating from the point source 1 arriving at a rectangular slit in the mask 2.

Using the simple Fresnel theory of the Cornu Spiral in which the obliquity factor of the incident light and the variation of amplitude with distance are not taken into account, the amplitude components of the diffraction pattern observable at a point having coordinates  $x, y$  on the substrate 3 can be deduced from distances  $s$  in the plane of the mask measured along the Cornu Spiral or vibration curve. The components are represented by:

$$C = \int_0^s \cos \frac{\pi s^2}{2} ds \text{ and } S = \int_0^s \sin \frac{\pi s^2}{2} ds$$

For any given point in the diffraction pattern the magnitude of  $S$  is given by  $S = \sqrt{2/b\lambda p}$ , where the values of  $p$  are derived from the appropriate coordinates of  $(x, y)$  the point in the transverse substrate plane in relation to the coordinates of the slit in the transverse

mask plane,  $b$  is the mask-to-substrate distance, and  $\lambda$  is the wavelength of the radiation (see FIG. 1). The diffraction pattern size is therefore proportional to the square root of the wavelength  $\lambda$ .

Typically the photosensitive resist deposited on the substrate 3 is sensitive to the three closely spaced wavelengths of the mercury spectrum, namely 365nm, 405nm and 436nm. However, since the diffraction produced is proportional to the square root of the wavelength, it is a justifiable approximation in practice to represent these three wavelengths by a single wavelength, in this case 400nm.

An analysis of the diffraction pattern produced by a line or slit can be performed according to this theory, which is found to give a good practical approximation, FIG. 2 shows, not to scale, the diffraction pattern produced on a substrate 3 spaced 12 microns from the mask 2 from a slit 3 microns wide.

It has been shown, for example by Michelson, that cancellation of diffraction fringes can be obtained using two diverging radiation waves (that is, from two sources). However, a combination of two sources is insufficient to produce cancellation in the different fringe patterns resulting from slits of different widths in a mask.

It has been found that a distribution of the illuminating source brightness can give rise to diffraction fringe compensation under certain conditions of slit width and mask-substrate separation.

In accordance with the present invention the intensity distribution in the diffraction pattern produced on the substrate 4 is effectively controlled by a suitable choice of the source geometry, departing from the point source shown in FIG. 1. For example, it has been found that substantial smoothing of the diffraction pattern over a certain range of the pattern on the substrate can be achieved by employing a source 1 of annular configuration.

Specifically, with a source producing radiation of wavelength 0.4 microns, it is found that an optimum source geometry is an annular source, or a source producing a beam which scans a conical path, such that radiation is incident on any given point on the mask 2 along rays which form the generators of a family of cones the common apex of which lies at the said point and the common axis of which is perpendicular to the mask, the family of cones having half-angles between  $3\frac{1}{4}^\circ$  and  $4\frac{3}{4}^\circ$ .

In FIG. 2 the typical diffraction pattern obtained on the substrate 3 using the point source 1 shown in FIG. 1, has superimposed on it, a corrected diffraction pattern, shown in broken outline, using illumination means in accordance with the invention of effectively annular brightness distribution produced by an orbiting source moving in a circular orbit of 0.144 radian diameter, the mask-substrate separation in this case being 12 microns.

FIGS. 3 to 6 illustrate different practical arrangements for providing the requisite illumination for shadow printing in accordance with the invention, utilising rotary optical elements.

In FIG. 3 light from the source 1 is directed by an inclined mirror 5 through a rotatable wedge prism 6 in a direction perpendicular to one of the faces of the prism, and thence through a collimating lens assembly 7 onto the mask-substrate combination 2, 3 to be illuminated. The prism 6 is driven at a constant rotational

speed by means of an electric motor 8 coupled to the prism housing through a belt drive 9, the axis of rotation of the prism 6 being coincident with the optical axis of the collimating lens assembly 7.

The rotation of the prism 6 at constant rotational speed during exposure of the substrate 3 through the mask 2 causes the collimated beam produced by the lens assembly 7 to perform a conical scan of the printing area, which is so arranged that the mask-substrate assembly 2, 3 is illuminated by an effectively annular source of kind previously specified.

FIG. 4 illustrates an alternative arrangement, similar to that of FIG. 3, in which the wedge prism 6 is mounted in a rotatable housing in the path of the collimated beam emerging from the collimating lens assembly 7.

In FIG. 5 a rotational mirror 10 is used to provide the conical scanning of the collimated light. The mirror 10 is arranged for rotation about an axis which is inclined to the normal to the reflecting surface of the mirror, so that light reflected by the mirror undergoes a conical scanning movement, the mirror being rotated at a constant speed about the aforesaid axis.

Light is directed onto the mirror 10 from the source 1 by means of a combination of lenses 11a and 11b and an internally reflecting pentaprism 12. The light from the source is collimated by lens 11a for passage through a pentaprism 12 and re-focussed by lens 11b to an image before passing to the rotating mirror 10 from a wide field of acceptance of light emitted by the source 1. After reflection at the mirror 10 the scanning light beam passes through the collimator 7 and thence onto the mask-substrate combination 2, 3.

FIG. 6 illustrates a yet further arrangement whereby the light emitted by the source 1 is directed by a means of a collecting lens assembly 14 into a rhomb prism 15 which is located in a housing and rotated about an offset axis X—X perpendicular to the plane parallel entry and exit faces of the prism 15. The emergent light is directed by a mirror 16 into the collimator 7 and thence onto the mask-substrate combination 2, 3, to produce on the latter a scanning conical beam as aforesaid.

FIGS. 7 and 8 illustrate embodiments of the invention utilising fixed optical elements.

The printing radiation is derived from a single source 1, in this case a substantially point source, which is arranged, by means of the optical system to be described, to illuminate a prepared substrate 3 having a photosensitive surface with radiation in a predetermined pattern.

The substrate 3 is disposed in a printing plane P (FIG. 8) and a mask 2 having a predetermined aperture pattern therein, shown in broken outline in FIG. 8, is positioned in front of the substrate 3. For shadow printing the mask 2 is spaced from the substrate 3 by a distance determined by analysis of typical image intensity distributions, calculated for constant angle of separation of illuminating beams, in this example substantially 9 microns, so that the conditions are established for Fresnel-Fraunhofer diffraction of the printing radiation at the mask 2. Typically the printing radiation emitted by the source 1 has a wavelength in the region of 0.4 micron.

Effective cancellation of diffraction fringes in the printing plane P is obtained by illuminating the printing plane P with radiation emanating from a source with effective annular brightness distribution comprising a

central dark area surrounded by a bright zone. This effective brightness distribution is achieved with a fixed optical system comprising, in FIGS. 7 and 8, a multiple prism 20 and a collimator indicated diagrammatically at 21. The collimator 21 may comprise a single lens or a group of lenses, as known per se. The source 1 is positioned on the axis of symmetry of the prism 20, this axis being disposed horizontally, and the axis of the collimator 21 is arranged vertically, light being deflected from the prism 20 downwardly into the collimator 21 by a plane mirror 22 inclined at 45° to the horizontal.

The multiple prism 20 comprises a number of identical prism elements 23 spaced apart at equal angular intervals in an annular array. In the illustrated example the multiple prism 20 is made up of six prism elements 23.

The multiple prism 20 has a circular outer edge, and each prism element 23 is sector shaped, its outer edge forming part of the circular outer edge of the prism 20. Each prism element 23 tapers from a maximum thickness at its vertex to each prism element 23 being inclined to the radial plane of the multiple prism 20, that is, the plane normal to the axis of symmetry of the prism 20. Typically the face 24 of each prism element 23 which faces towards the source 1 has an inclination of 78°-79° to the axis of symmetry of the prism 20, while the opposite face, 25, of each prism element 23 is inclined, in the opposite direction, at an angle of substantially 63°-64° to the said axis of symmetry.

Each sector shaped prism element 23 is truncated at its vertex so that the multiple prism 20 has a central portion 26, with plane parallel outer faces, the central portion 26 being in this case in the form of a hexagonal parallelepiped.

The respective prism elements 23 are conveniently formed in practice by grinding respective facets on two circular discs to form the respective faces 24, 25 thereon. The two discs are then cemented together along their plane faces so that the surfaces 24, 25 face outwardly and are angularly aligned to form the respective prism element 23.

The radiation emitted by the source 1 and impinging on the multiple prism 20 is divided by the prism 20 into a number of component beams equal in number to the number of prism elements 23. In FIG. 8, two of the prism elements 23, diametrically opposite each other, are shown, with associated rays passing therethrough. Upon reflection in the mirror 22 the respective beams are reflected downwardly as divergent beams defining respective virtual images of the source 1, two of which 1', 1'', are shown in FIG. 2. These beams are brought together in the printing plane P by the collimator 21, as shown diagrammatically in FIG. 8. The relative divergence of the collimated beams at the printing plane P is typically 0.14 radian.

The beams incident on the printing plane P have an effective intensity distribution such as to produce in the printing plane P an illuminating condition comprising a central dark zone surrounded by a number of (in this example six) bright zones distributed regularly in an annular pattern around the dark zone. This approximates to the ideal annular illumination pattern for producing diffraction compensation in the printing plane P.

The surfaces of the light transmitting components in the optical system are preferably coated so as to afford optimum transmission of the printing radiation: in this example all such surfaces, including the faces 24, 25 of

the prism elements 23, would be coated for best transmission in the wavelength range 0.36-0.44 micron. In effect the optical system herein described produces six collimated beams. Accordingly the illumination intensity afforded by this technique is substantially greater than that which is possible using a single orbiting source or light beam, and the same collimating lenses.

FIGS. 9 and 10 show an alternative embodiment which is similar to that of FIGS. 7 and 8, but in which the multiple prism 20 has been replaced by a composite reflector 30.

The composite reflector 30 comprises a number of (six in this example) identical plane mirrors 31 arranged in an annular (hexagonal) array, as shown in FIG. 10, with the point source 1 positioned on the axis 32 of the array. Each mirror is inclined at an equal small angle to the axis 32 of the array so that light from the source 1 is split by the reflector 30 into divergent component beams, equal in number to the number of mirrors 31, which diverge from respective virtual images 33 lying in a common plane containing the point source 1, as shown in FIG. 9.

The component divergent beams produced by the composite reflector 30 are deflected by the plane mirror 22, inclined at 45° to the axis 32, into the collimator 21 to form the desired distribution of illumination in the printing plane P, as previously described with reference to FIGS. 7 and 8.

Light from the point source 1 is prevented from passing directly to the collimator 21 without reflection in the annular array of mirrors 31 by a centrally positioned stop 34.

I claim:

1. Apparatus for illuminating a substrate with a pattern determined by a shadow mask having transparent regions and opaque regions collectively defining a pattern to be illuminated on said substrate, comprising:
  - a light source assembly of finite predetermined area having an effective brightness distribution incorporating a dark central region surrounded by a bright rim and producing substantially coherent light at a selected wavelength,
  - a shadow mask bearing said pattern to be imaged on said substrate,
  - means supporting said mask at a selected position between said substrate and said light source assembly in the path of the light therefrom, said selected position lying at a distance from said substrate of the same order as the width of said transparent portions of said mask, whereby diffraction of light passing through said transparent regions in said mask results in diffraction fringes which substantially cancel each other out at least adjacent the edges of the pattern determined by said transparent regions, so that a sharp image of said shadow mask is obtained on said substrate when illuminated by said source assembly.
2. Illumination means according to claim 1, in which said source assembly has an annular shape.
3. Illumination means according to claim 1, in which said effective brightness distribution of the source assembly comprises a number of bright zones distributed regularly in an annular pattern around the central dark zone.
4. Illumination means according to claim 1, in which the source assembly comprises a source and means ef-

fecting orbital movement of said source around a circular path to provide an annular effective brightness distribution over the period of an exposure.

5. Illumination means according to claim 1, in which the source assembly comprises a source providing a collimated light beam and means scanning said beam over a conical or cylindrical surface cyclically.

6. Illumination means according to claim 5, in which said scanning means comprises a reflecting element mounted for rotation in the path of said collimated light beam, and means rotating said element to effect scanning of said beam.

7. Illumination means according to claim 5, in which said scanning means comprises a refracting element mounted for rotation in the path of said collimated light beam, and means rotating said element to effect scanning of said beam.

8. Illumination means according to claim 7, in which the rotatable refracting element comprises a rotatable wedge prism mounted in the path of said light beam from said source, and a collimator through which said beam passes after traversing said prism, the resulting collimated beam performing a conical scan upon rotation of the wedge prism.

9. Illumination means according to claim 7, in which the rotatable refracting element comprises a rotatable wedge prism mounted in the path of the said beam, and including a collimator interposed between the prism and the source, so that the collimated beam upon emerging from the prism performs a conical scan upon rotation of the prism.

10. Illumination means according to claim 6, in which the rotatable reflecting element comprises a plane mirror mounted for rotation about an axis which is inclined to the normal to the reflecting surface of the mirror and including a collimator, said plane mirror being positioned in said light path between the light source and said collimator, the resulting collimated beam performing a conical scan upon rotation of the mirror.

11. Illumination means according to claim 7, in which the rotatable refracting element comprises a rhomb prism mounted for rotation about an axis perpendicular to two plane parallel faces through which said light beam passes.

12. Illumination means according to claim 1, in which the source assembly provides light having a wavelength of substantially 0.4 microns and said means supporting said mask a selected distance from said substrate supports said mask between about 9 and 12 microns from said substrate.

13. Illumination means according to claim 3, in which the source comprises in combination a single point source and a fixed multiple prism comprising a number of prism elements arranged in an annular array such that light from the point source passes through the said prism elements to provide the same number of component beams.

14. Illumination means according to claim 13 including a collimator through which said component beams pass to produce the said effective illumination condition in a printing plane.

15. Illumination means according to claim 14, including a collimator through which said component beams pass to produce the same illumination condition in a printing plane.

16. A method according to claim 15 in which the mean half-angle of the family of cones contained in the said envelope lies within the range  $1\frac{1}{2}^{\circ}$  to  $5^{\circ}$ .

17. Illumination means according to claim 3, in which the source comprises a single point source and a fixed composite reflector having a number of reflector elements arranged in an annular array such that light from the point source forms, by reflection in said reflector elements, the same number of component beams.

18. Apparatus for illuminating a substrate with a pattern determined by a shadow mask having transparent regions and opaque regions collectively defining a pattern to be illuminated on said substrate, comprising:

15 a light source assembly of finite predetermined area having an effective brightness distribution incorporating a dark central region and a bright surrounding rim, said light source assembly including, in combination:

20 a single point source of light of a given wavelength,

a fixed composite optical arrangement having a plurality of optical elements in an annular array inclined such that light from said point source impinges on said optical elements and is formed thereby into a plurality of component beams in a corresponding annular array, and

25 collimating lens means in the path of said plurality of component beams,

30 a shadow mask having transparent regions and opaque regions collectively defining said pattern to be imaged on said substrate, and

means supporting said mask at a selected position between said substrate and said light source assembly in the path of the light therefrom, said selected position lying at a distance from said substrate of the same order as the width of said transparent portions of said mask, whereby diffraction of light passing through said transparent regions in said mask results in diffraction fringes which substantially cancel each other out at least adjacent the edges of the pattern determined by said transparent regions, so that a sharp image of said shadow mask is obtained on said substrate when illuminated by said source assembly.

19. Illumination means according to claim 18, in which said optical arrangement comprises a fixed multiple prism comprising a number of prism elements arranged in an annular array, light from said point source passing through the said prism elements to provide the same number of component beams.

20. Illumination means according to claim 19, in which said prism comprises a number of identical adjacent prism elements of sector shape, each prism element tapering in thickness from a maximum at its vertex to a minimum at its outer edge.

21. Illumination means according to claim 20, in which the outer edges of the prism elements lie on a common circle.

22. Illumination means according to claim 20, in which each prism element is truncated at its vertex, said multiple prism having a central portion with plane parallel outer faces.

23. Illumination means according to claim 19, in which the two outer faces of each prism element are both inclined to the radial plane of the multiple prism.

24. Illumination means according to claim 23, in which the multiple prism comprises two parts, each ground to provide respective parts of said prism elements, and each having a plane radial face, said two parts being cemented together back-to-back at said plane faces with the parts of the prism elements in register with each other.

25. Illumination means according to claim 19, in which said multiple prism comprises at least six identical prism elements.

26. Illumination means according to claim 18, in which said optical elements are reflectors and are so arranged that they form virtual images of the said point light source in a common plane containing said point source.

27. Illumination means according to claim 18, including a stop arranged centrally of the annular array of reflector elements, preventing the direct passage of light through said array without reflection by the reflector elements.

28. Illumination means according to claim 18, including a fixed reflector between said array of optical elements and said collimator, the component beams emerging from said composite optical arrangement being deflected through substantially 90° by said fixed reflector before passing through said collimator.

29. A method of shadow printing a pattern from a shadow mask onto a radiation sensitive substrate, comprising the steps of:

positioning in approximately parallel relation to said substrate a shadow mask having transparent and opaque regions collectively defining the pattern desired for said substrate,

spacing said shadow mask from said substrate by a distance of the same order as the widths of said transparent regions of said mask, and

illuminating said substrate via said shadow mask with light of a given wavelength from a light source having an effective brightness distribution incorporating a dark central region surrounded by a bright rim so that the illumination condition of said substrate is such that fringes formed on the substrate adjacent the edges of the images of said opaque regions of said mask, on said substrate, substantially cancel one another out to provide a sharp image of said pattern defined by said mask.

30. The method according to claim 29 comprising the step of illuminating said shadow mask and substrate with light from a stationary source assembly of finite predetermined area and comprising:

a single point source of light of a given wavelength,

a fixed composite optical arrangement having a plurality of optical elements in an annular array inclined such that light from said point source impinges on said optical elements and is formed thereby into a plurality of component beams in a corresponding annular array, and

lens means in the path of said plurality of component beams.

31. The method according to claim 29 wherein said given wavelength of light is substantially 0.4 microns and said mask is spaced from said substrate by substantially 9 microns.

32. The method according to claim 29, in which the source illuminates any point on the mask with radiation which lies between two cones having a common apex at said point and a common axis normal to the plane of the mask.

33. The method according to claim 32, in which said two cones have half-angles of 3¼° and 4¼°.

\* \* \* \* \*

40

45

50

55

60

65