



(11) **EP 3 655 113 B1**

(12) **EUROPEAN PATENT SPECIFICATION**

(45) Date of publication and mention of the grant of the patent:
17.03.2021 Bulletin 2021/11

(21) Application number: **18742961.8**

(22) Date of filing: **10.07.2018**

(51) Int Cl.:
A62B 18/00 (2006.01)

(86) International application number:
PCT/EP2018/068589

(87) International publication number:
WO 2019/016018 (24.01.2019 Gazette 2019/04)

(54) **A MASK AND CONTROL METHOD**

MASKE UND STEUERUNGSVERFAHREN

MASQUE ET PROCÉDÉ DE COMMANDE

(84) Designated Contracting States:
AL AT BE BG CH CY CZ DE DK EE ES FI FR GB GR HR HU IE IS IT LI LT LU LV MC MK MT NL NO PL PT RO RS SE SI SK SM TR

(30) Priority: **17.07.2017 PCT/CN2017/093086**
15.08.2017 EP 17186248

(43) Date of publication of application:
27.05.2020 Bulletin 2020/22

(73) Proprietor: **Koninklijke Philips N.V.**
5656 AG Eindhoven (NL)

(72) Inventors:
• **SHI, Jun**
5656 AE Eindhoven (NL)
• **SU, Wei**
5656 AE Eindhoven (NL)

- **ZHANG, Qiushi**
5656 AE Eindhoven (NL)
- **CHEN, Weizhong**
5656 AE Eindhoven (NL)
- **CHEN, Shuang**
5656 AE Eindhoven (NL)
- **ZHANG, Xuan**
5656 AE Eindhoven (NL)

(74) Representative: **Philips Intellectual Property & Standards**
High Tech Campus 5
5656 AE Eindhoven (NL)

(56) References cited:
WO-A1-2016/157159 WO-A2-2004/112680
CN-A- 104 548 406 JP-A- 2008 295 993

EP 3 655 113 B1

Note: Within nine months of the publication of the mention of the grant of the European patent in the European Patent Bulletin, any person may give notice to the European Patent Office of opposition to that patent, in accordance with the Implementing Regulations. Notice of opposition shall not be deemed to have been filed until the opposition fee has been paid. (Art. 99(1) European Patent Convention).

Description

FIELD OF THE INVENTION

[0001] This invention relates to a mask and control method particularly to a mask for providing filtered air to the wearer of the mask, with the flow assisted by fans.

BACKGROUND OF THE INVENTION

[0002] Air pollution is a worldwide concern. The World Health Organization (WHO) estimates that 4 million people die from air pollution every year. Part of this problem is the outdoor air quality in cities. The worst in class are Indian cities like Delhi that have an annual pollution level more than 10 times the recommended level. Also well-known is Beijing, with an annual average 8.5 times the recommended safe levels. However, even in European cities like London, Paris and Berlin, the levels are higher than recommended by the WHO.

[0003] A significant contributor to air pollution is particulate matter suspended in the air. Particle pollution comes both from natural sources (such as volcanoes, dust storms, forest and grassland fires, living vegetation and sea spray) and from human activities (such as burning of fuels, transportation, power plants and various industrial processes). Besides these primary sources of particles, there are also secondary sources, which are fine particles generated through complicated atmospheric chemistry reactions of gas pollutants. Secondary sources include inorganic fine particles (e.g. sulfates, nitrates and ammonium salts generated by SO₂, NO₂, NH₃) and organic fine particles (generated by oxidation of volatile organic gases).

[0004] Official outdoor air quality standards define particle matter concentration as mass concentration per unit volume (e.g. µg/m³). A particular concern is pollution with particles having a diameter less than 2.5 µm (termed "PM2.5") as they are able to penetrate into the gas exchange regions of the lung (alveoli), and very small particles (<100 nm) may pass through the lungs to affect other organs.

[0005] Since this problem will not improve significantly on a short time scale, the only way to deal with this problem is to wear a mask which provides cleaner air by filtration. To improve comfort and effectiveness, a fan can be added to the mask which draws in air through a filter. For efficiency and longevity reasons these are normally electrically commutated brushless DC fans.

[0006] The benefit to the wearer of using a powered mask is that the lungs are relieved of the slight strain caused by inhalation against the resistance of the filters in a conventional non-powered mask.

[0007] Furthermore, in a conventional non-powered mask, inhalation also causes a slight negative pressure within the mask which leads to leakage of the contaminants into the mask, which leakage could prove dangerous if these are toxic substances. A powered mask de-

livers a steady stream of air to the face and may for example provide a slight positive pressure, which may be determined by the resistance of an exhale valve, to ensure that any leakage is outward rather than inward.

[0008] There have been numerous approaches to improving the user experience when wearing a powered mask. The approaches have tended to focus on regulation of fan speeds, both to improve user comfort and to improve the electrical efficiency of the fan.

[0009] For example, GB 2 032 284 discloses a respirator in which the pressure inside a mask is measured by a pressure sensor and the fan speed is varied in dependence on the sensor measurements.

[0010] WO 2016/157159 discloses a respiratory mask having different inlet and outlet paths for the user's breath. It also discloses that a fan can be used in either or both of the inlet and outlet paths.

[0011] CN 104 548 406 discloses a respiratory mask comprising a vent hole and a fan for drawing air in through the vent hole.

[0012] JP 2008 295993 discloses a respiratory mask for filtering the air breathed by a user, comprising a photocatalyst and a fan.

[0013] However, there remains a need for further improvements in the comfort of the user when using a mask.

SUMMARY OF THE INVENTION

[0014] The invention is defined by the claims.

[0015] According to examples in accordance with an aspect of the invention, there is provided a mask comprising:

an air chamber;

a filter;

an inhalation fan for drawing air through the filter from outside the air chamber into the air chamber; an exhalation fan for drawing air from inside the air chamber to the outside;

a sensor for detecting an inhalation and an exhalation of a user; and

a controller which is adapted to:

continuously run the inhalation and exhalation fans when the mask is being worn by the user; determine via the sensor whether the user is inhaling or exhaling; and

increase a rotation speed of the inhalation fan relative to a rotation speed of the exhalation fan at the start of inhalation; and

increase the rotation speed of the exhalation fan relative to the rotation speed of the inhalation fan at the start of exhalation.

[0016] The mask of the present invention ensures that inhalation is assisted by the inhalation fan and exhalation is assisted by the exhalation fan, whilst keeping the other

fan (the exhalation fan in the case of inhalation and the inhalation fan in the case of exhalation) at a suitable rotation speed such that fan speed adjustments can be made more quickly when there are transitions between inhalation and exhalation. The inhalation and exhalation fans thus work together and the rotation speeds of the inhalation and exhalation fans are carefully controlled to minimize the counteraction between the fans and to facilitate the synchronization of the air flow in the mask with the breathing of the user, making breathing in the mask more comfortable.

[0017] The reference to "at the start of inhalation" and "at the start of exhalation" relates to the point in time at which the sensor detects that inhalation or exhalation has started. This may not correspond exactly to the breathing cycle of the user as there will be some sensing time lag. However, this will be negligible compared to the overall duration of the inhalation and exhalation cycles of the user.

[0018] In one embodiment, the sensor comprises a differential pressure sensor for determining a difference in pressure between air outside the air chamber and air inside the air chamber. Differential pressure sensors are readily available and easy to use.

[0019] The rotation speed is preferably increased by pulse width modulation having a duty cycle. Pulse width modulation is a common technique that allows simple control of the rotation speed.

[0020] In another embodiment, the inhalation and exhalation fans are driven by an electronically commutated brushless motor. Electronically commutated brushless motors are preferred for efficiency and longevity reasons.

[0021] Considering the rotation speed in further detail, the inhalation fan has a first rotation speed and a second rotation speed, and the exhalation fan has a first rotation speed and a second rotation speed, and the second rotation speed is higher than the first rotation speed. This provides a low idling speed which uses minimal power, but reduces latency. For example, the first rotation speed of both fans is usually 10-500, preferably 50-100 rpm. The second rotation speed is usually 5-50, preferably 10-30 times higher than the first rotation speed. This provides a significant increase to assist the breathing of the user. Further, the second rotation speed may be tailored to the breathing of the user (e.g. breath frequency and tidal volume) and may be adjusted to take into account different breathing scenarios (e.g. walking and running).

[0022] The first rotation speed of the inhalation fan is preferably the same as the first rotation speed of the exhalation fan. This provides a consistent user experience, in terms of feel and sound. The second rotation speed of the inhalation fan may be the same as or different to the second rotation speed of the exhalation fan, depending on the design of the inlet and outlet flow paths of the mask and the differential pressure inside the mask created by the inhalation fan and the exhalation fan. For example, if air is drawn into the mask through the filter and drawn out of the mask through a valve, the inhalation

fan would need to generate a higher pressure than the exhalation fan. This could be achieved using a higher second rotation speed for the inhalation fan than for the exhalation fan.

[0023] In one embodiment, the mask further comprises a switch for starting and stopping the inhalation and exhalation fans. This would allow the user to have full control over when to start and stop the inhalation and exhalation fans. For example, the user could ensure that the inhalation and exhalation fans are switched off at all times when the mask is not in use.

[0024] There may instead be detection of when the mask is being worn to provide automatic control of the fans.

[0025] The filter comprises a filter member in series with the inhalation fan. The outer wall of the air chamber may define the filter or else a filter may be provided only at the location of the inhalation fan. In this way, the air entering the mask is filtered.

[0026] In another aspect of the invention, there is provided a method of controlling a mask, comprising:

continuously running an inhalation fan and an exhalation fan when the mask is being worn by a user;
drawing air into and out of an air chamber of the mask using the inhalation and exhalation fans;
detecting an inhalation and an exhalation of the user;
determining whether the user is inhaling or exhaling;
and
increasing a rotation speed of the inhalation fan relative to a rotation speed of the exhalation fan at the start of inhalation, and
increasing the rotation speed of the exhalation fan relative to the rotation speed of the inhalation fan at the start of exhalation.

BRIEF DESCRIPTION OF THE DRAWINGS

[0027] Examples of the invention will now be described in detail with reference to the accompanying drawings, in which:

Fig. 1 shows a mask containing an inhalation fan and an exhalation fan;

Fig. 2 shows one example of the components of the mask;

Fig. 3 shows the relative rotation speeds of the inhalation and exhalation fans in use;

Figs. 4a and 4b shows the pulse width modulations of the inhalation and exhalation fans during use corresponding to the first and second rotation speeds of Fig. 3;

Fig. 5 shows a mask operating method.

DETAILED DESCRIPTION OF THE EMBODIMENTS

[0028] The invention provides a breathing assistance mask. A mask is provided that incorporates an air cham-

ber, a filter, an inhalation fan, an exhalation fan, a sensor and a controller. The inhalation fan draws air through the filter and into the mask. The exhalation fan exhausts the exhaled air. The controller continuously runs the inhalation and exhalation fans when the mask is being worn. The controller provides a first and second rotation speed for the fans, with the first rotation speed being non-zero and lower than the second rotation speed. During inhalation, the exhalation fan runs at the first inhalation speed and the inhalation fan runs at the second inhalation speed. During exhalation, the inhalation fan runs at the first inhalation speed and the exhalation fan runs at the second inhalation speed. The control of the inhalation and exhalation fans ensures that the air flow in the mask is synchronized with the breathing of the user, ultimately making breathing more comfortable in the mask.

[0029] The inhalation fan and exhalation fan work together to generate a flow of air through the mask. However, it has been found that they counteract each other, disrupting the flow of air through the mask. In particular, investigations performed by the applicant have found latency problems when switching between inhalation and exhalation fans during use. This has been found to be a factor in poor synchronization with the breathing of the user, making breathing uncomfortable.

[0030] In the mask of the invention, an inhalation fan and an exhalation fan are continuously run so that their rotation speeds never fall back to zero. This reduces the start-up latency of the fans and minimizes the time it takes for the air flow in the mask to synchronize with the breathing of the user. Continuously running the inhalation and exhalation fans at least a minimum level ensures that there is minimal delay when switching the operation of the inhalation fan to the exhalation fan during the transition between inhalation and exhalation, and when switching the operation of the exhalation fan to the inhalation fan during the transition between exhalation and inhalation. The impulse required to change the fan speed during use is thus reduced so that the desired fan speed changes can be made more quickly. Thus, the air flow in the mask may be synchronized more easily with the breathing of the user, ultimately making breathing in the mask more comfortable.

[0031] By determining via a sensor whether the user is inhaling or exhaling, a controller is able to adjust the rotation speed of the inhalation fan and the rotation speed of the exhalation fan. The controller is adapted to increase the rotation speed of the inhalation fan relative to the rotation speed of the exhalation fan when the user starts an inhalation cycle, and increase the rotation speed of the exhalation fan relative to the rotation speed of the inhalation fan when the user starts an exhalation cycle. This reduces the interference between the inhalation and exhalation fans so that again the air flow in the mask is synchronized with the breathing of the user, ultimately making breathing in the mask more comfortable.

[0032] Fig. 1 shows a mask of the invention containing an inhalation fan and an exhalation fan.

[0033] A user 10 is shown wearing a face mask 11 which covers at least the nose and mouth of the user. The purpose of the mask is to filter air before it is breathed in by the user. For this purpose, in Fig. 1, the mask body itself acts as an air filter 12. Air is drawn into an air chamber 13 formed by the mask by inhalation. An inhalation fan 14 assists in the drawing of air through the filter 12 from outside the air chamber 13 into the air chamber 13. The inhalation fan 14 is positioned before or after the filter 12.

[0034] When the subject breathes out, air is exhausted through the air chamber 13 by exhalation. An exhalation fan 15 assists in the drawing of air from inside the air chamber 13 to the outside. The exhaust air does not need to pass through the filter, but it could be drawn through the filter by the exhalation fan as well.

[0035] In use, the inhalation fan 14 and the exhalation fan 15 are run continuously. This avoids start-up latency. Running the inhalation and exhalation fans continuously means that the impulse required to change the fan speed settings during use is reduced so that the air flow in the mask synchronizes with the breathing of the user, ultimately making breathing in the mask more comfortable.

[0036] Fig. 2 shows one example of the components of the mask. The same components as in Fig. 1 are given the same reference numbers.

[0037] In addition to the components shown in Fig. 1, Fig. 2 shows a controller 20, a local battery 21 and a sensor 22 for detecting the inhalation or the exhalation of the user.

[0038] The inhalation fan 14 comprises a fan blade 14a and a fan motor 14b. The exhalation fan 15 comprises a fan blade 15a and a fan motor 15b. In one example, the fan motors 14b and 15b are electronically commutated brushless motors. Electronically commutated brushless DC fans have internal sensors that measure the position of the rotor and switch the current through the coils in such a way that the rotor rotates.

[0039] The sensor 22 for detecting an inhalation and an exhalation of the user may be a differential pressure sensor for determining a difference in pressure between air outside the air chamber and air inside the air chamber. For example, for a known pressure (e.g. atmospheric pressure) at one side of the inhalation and exhalation fans, the pressure monitoring enables determination of a pressure, or at least a pressure change, on the other side of the inhalation and exhalation fans. This other side is for example a closed chamber which thus has a pressure different to atmospheric pressure. In this way, inhalation and exhalation may be detected.

[0040] By detecting equal pressure on each side of the inhalation and exhalation fans, it can then be determined that the chamber is not closed but is connected to atmospheric pressure on both sides. In this way, no inhalation and exhalation is detected. This can also signal that the mask is not being worn, and can thus be used to switch off the fans to save power.

[0041] The pressure difference information is transmit-

ted to the controller 20. The controller 20 then determines whether the user is inhaling or exhaling. For example, a decrease in pressure in the air inside the air chamber relative to the air outside the air chamber would correspond to an inhalation and an increase in pressure in the air inside the air chamber relative to the air outside the air chamber would correspond to an exhalation.

[0042] A suitable differential pressure sensor is one from the Sensirion (Trade Mark) SPD60x series. In another embodiment, the sensor comprises a differential pressure sensor having a measurement range of -500 to 500 Pa. This covers the breathing pressure range. Other sensors can also be used to determine whether a user is inhaling or exhaling. For example, temperature, humidity, carbon dioxide, oxygen or a combination of any of the above sensors may be used.

[0043] If a transition from exhalation to inhalation is determined, the controller 20 sends a signal to the inhalation fan motor 14b to increase the rotation speed of the inhalation fan blade 14a and sends a signal to the exhalation fan motor 15b to decrease the rotation speed of the exhalation fan blade 15a. In this way, the rotation speed of the inhalation fan increases relative to the rotation speed of the exhalation fan. Conversely, if a transition from inhalation to exhalation is determined, the controller 20 sends a signal to the exhalation fan motor 15b to increase the rotation speed of the exhalation fan blade 15a and sends a signal to the inhalation fan motor 14b to decrease the rotation speed of the inhalation fan blade 14a. In this way, the rotation speed of the exhalation fan increases relative to the rotation speed of the inhalation fan.

[0044] In a most simple example, the rotation speeds of the inhalation and exhalation fans alternate between two set values, with the changes in rotation speed implemented at the detection transitions between inhalation and exhalation.

[0045] Fig. 3 shows the relative rotation speeds of the inhalation and exhalation fans in use. In the mask of the invention, the inhalation fan 14 has a first rotation speed ("1") and a second rotation speed ("2"). Similarly, the exhalation fan 15 has a first rotation speed ("1") and a second rotation speed ("2"). In both cases, the second rotation speed is higher than the first rotation speed.

[0046] In Fig. 3, the inhalation and exhalation fans 14, 15 alternate between level 1 and level 2. Level 1 represents the first rotation speed and level 2 represents the second rotation speed. The first rotation speed is a minimum, non-zero rotation speed. In use, the fans will not operate below the first rotation speed, i.e. they are running continuously.

[0047] The second rotation speed is higher than the first rotation speed, for both the inhalation 14 and exhalation 15 fans.

[0048] Fig. 3 starts on an exhalation. On exhalation, exhalation fan 15 is at level 2 and inhalation fan 14 is at level 1. In this way, the rotation speed of the exhalation fan 15 is higher than the rotation speed of the inhalation

fan 14. On detection of the subsequent inhalation, the speed of inhalation fan 14 increases to level 2 and the speed of exhalation fan 15 decreases to level 1.

[0049] When inhalation is determined, the rotation speed of the inhalation fan 14 increases relative to the rotation speed of the exhalation fan 15. When exhalation is determined, the rotation speed of the exhalation fan 15 increases relative to the rotation speed of the inhalation fan 14. In this way, the air flow in the mask is synchronized with the breathing of the user, ultimately making breathing in the mask more comfortable. The rotation speed of the inhalation and exhalation fan is varied by varying the supplied voltage.

[0050] Preferably, more air is removed than exhaled so that additional air is supplied to the face. This increases comfort owing to a lowering of the relative humidity and cooling.

[0051] Typically, the first rotation speed of the inhalation fan 14 is the same as the first rotation speed of the exhalation fan 15. For example, the first rotation speed of the inhalation fan 14 and the first rotation speed of the exhalation fan 15 may be 10-500 rpm, more preferably 50-100 rpm.

[0052] The second rotation speed of the inhalation fan 14 and the second rotation speed of the exhalation fan 15 may be 5-50 times higher than the first rotation speeds, more preferably 10-30 times. The second rotation speed may be tailored to the breathing of the user (e.g. breath frequency and tidal volume) and may be adjusted to take into account different breathing scenarios (e.g. walking and running).

[0053] Thus, on inhalation, the increase in the rotation speed of the inhalation fan 14 relative to a rotation speed of the exhalation fan 15 is preferably provided by the controller causing the inhalation fan 14 to run at its second rotation speed and the exhalation fan 15 to run at its first rotation speed. Conversely, on exhalation, the increase in the rotation speed of the exhalation fan 15 relative to a rotation speed of the inhalation fan 14 is preferably provided by the controller causing the inhalation fan 14 to run at its first rotation speed and the exhalation fan 15 to run at its second rotation speed.

[0054] The rotation speeds to be used may be determined during a calibration process or they may be provided by the fan manufacturer. The calibration process for example involves analyzing the fan speed information over a period during which the user is instructed to inhale and exhale regularly with normal breathing. The captured fan speed information can then be used to determine the first, second and any intermediate rotation speeds. The controller may also provide for settings for the user to regulate the rotation speeds of the first, second and any intermediate rotation speeds.

[0055] There may also be a number of intermediate rotation speeds at which the inhalation and exhalation fans may be run between the first and second rotation speeds. However, the first rotation speed normally sets the minimum rotation speed. The minimum speed ideally

provides an optimum balance between lag time and power efficiency. The second rotation speed is typically dependent on the breathing of the user (e.g. breath frequency and tidal volume) and could be adjusted to take into account different breathing scenarios (e.g. walking and running). In one simple embodiment, the second rotation speed sets the maximum rotation speed. In this way, the second rotation speed ideally provides an optimum balance between lag time and power efficiency on the one hand, and the assistance given to the user on the other.

[0056] In one embodiment, the rotation speeds of the inhalation and exhalation fans are controlled by a pulse width modulation signal, whereby the duty cycle controls the rotation speed.

[0057] Figs. 4a and 4b show examples of the pulse width modulations that can be used to increase the rotation speed of the inhalation and exhalation fans. The pulse width modulation shown in Fig. 4a corresponds to level 1 in Fig. 3 (first rotation speeds) and the pulse width modulation shown in Fig. 4b corresponds to level 2 in Fig. 3 (second rotation speeds). As can be seen from Figs. 4a and 4b, the first rotation speed has a lower duty cycle than the second rotation speed.

[0058] When the mask is not in use, it may be switched off. In one embodiment, the mask comprises a switch for starting and stopping the inhalation fans. When the mask is switched on, both fans may start operating at a first rotation speed. Alternatively, the fans may start when the mask is worn by the user. In this embodiment, the sensor in the mask may be used to determine when the mask is being worn and start the fans. The mask may then go straight into its operating mode with the fan speeds being determined by the point in the user's inhalation/exhalation cycle.

[0059] Fig. 5 shows a mask operating method. The method comprises:

- in step 50, continuously running an inhalation fan and an exhalation fan when the mask is being worn by a user;
- in step 51, drawing air into and out of an air chamber of the mask using the inhalation and exhalation fans;
- in step 52, detecting an inhalation and an exhalation of the user;
- in step 53, determining whether the user is inhaling or exhaling; and
- in step 54, increasing a rotation speed of the inhalation fan relative to a rotation speed of the exhalation fan on inhalation, and increasing the rotation speed of the exhalation fan relative to the rotation speed of the inhalation fan on exhalation.

[0060] Therefore, the flow of the forced air through the mask synchronizes with the breathing of the user, making breathing in the mask more comfortable. The mask may be for covering only the nose and mouth (as shown in Fig. 1) or it may be a full face mask.

[0061] The example shown is a mask for filtering ambient air. However, the mask may be used with a breathing gas from an external supply, for example a breathing assistance device, such as a continuous positive air pressure (CPAP) system.

[0062] The mask design described above has the main air chamber formed by the filter material, through which the user breathes in air.

[0063] An alternative mask design has the filter in series with the fan as also mentioned above but has a non-permeable outer housing. In this case, the inhalation fan assists the user in drawing in air through the filter, thus reducing the breathing effort for the user. An inlet valve may be provided adjacent to the inhalation fan and an outlet valve may be provided adjacent to the exhalation fan.

[0064] It will be seen that the invention may be applied to many different mask designs, with fan-assisted inhalation and exhalation, and with an air chamber formed by a filter membrane or with a sealed hermetic air chamber.

[0065] As discussed above, embodiments make use of a controller, which can be implemented in numerous ways, with software and/or hardware, to perform the various functions required. A processor is one example of a controller which employs one or more microprocessors that may be programmed using software (e.g. microcode) to perform the required functions. A controller may however be implemented with or without employing a processor, and also may be implemented as a combination of dedicated hardware to perform some functions and a processor (e.g. one or more programmed microprocessors and associated circuitry) to perform other functions.

[0066] Examples of controller components that may be employed in various embodiments of the present disclosure include, but are not limited to, conventional microprocessors, application specific integrated circuits (ASICs), and field-programmable gate arrays (FPGAs).

[0067] In various implementations, a processor or controller may be associated with one or more storage media such as volatile and non-volatile computer memory such as RAM, PROM, EPROM, and EEPROM. The storage media may be encoded with one or more programs that, when executed on one or more processors and/or controllers, perform the required functions. Various storage media may be fixed within a processor or controller or may be transportable, such that the one or more programs stored thereon can be loaded into a processor or controller.

[0068] Other variations to the disclosed embodiments can be understood and effected by those skilled in the art in practicing the claimed invention, from a study of the drawings, the disclosure, and the appended claims. In the claims, the word "comprising" does not exclude other elements or steps, and the indefinite article "a" or "an" does not exclude a plurality. The mere fact that certain measures are recited in mutually different dependent claims does not indicate that a combination of these

measures cannot be used to advantage. Any reference signs in the claims should not be construed as limiting the scope.

Claims

1. A mask (11) comprising:

an air chamber (13);
 a filter (12);
 an inhalation fan (14) for drawing air through the filter from outside the air chamber (13) into the air chamber (13);
 an exhalation fan (15) for drawing air from inside the air chamber (13) to the outside;
 a sensor (22) for detecting an inhalation and an exhalation of a user (10); and a controller (20) which is adapted to:

continuously run the inhalation fan (14) and the exhalation fan (15) when the mask is being worn by the user;
 determine via the sensor (22) whether the user is inhaling or exhaling; and
 increase a rotation speed of the inhalation fan (14) relative to a rotation speed of the exhalation fan (15) at the start of inhalation, and

increase the rotation speed of the exhalation fan (15) relative to the rotation speed of the inhalation fan (14) at the start of exhalation.

2. A mask as claimed in claim 1, wherein the sensor (22) comprises a differential pressure sensor for determining a difference in pressure between air outside the air chamber (13) and air inside the air chamber (13).

3. A mask as claimed in any preceding claim, wherein the rotation speed is controlled by a pulse width modulation signal.

4. A mask as claimed in any preceding claim, wherein the inhalation and exhalation fans (14, 15) are driven by electronically commutated brushless motors.

5. A mask as claimed in any preceding claim, wherein the inhalation fan (14) has a first rotation speed and a second rotation speed, and the exhalation fan (15) has a first rotation speed and a second rotation speed, and the second rotation speed of both fans is higher than the first rotation speed of both fans.

6. A mask as claimed in claim 5, wherein the first rotation speed of both fans is 10-500 rpm.

7. A mask as claimed in claim 5 or 6, wherein the second rotation speed of both fans is 5-50 times higher than the first rotation speed of both fans.

8. A mask as claimed in any of claims 5-7, wherein the first rotation speed of the inhalation fan (14) is the same as the first rotation speed of the exhalation fan (15).

9. A mask as claimed in any preceding claim, wherein the mask further comprises a switch for starting and stopping the inhalation and exhalation fans (14, 15).

10. A mask as claimed in any preceding claim, wherein the filter (12) comprises an outer wall of the air chamber (13), or a filter member in series with the inhalation fan (14).

11. A method of controlling the mask (11) of any preceding claim comprising:

continuously running an inhalation fan (14) and an exhalation fan (15) when the mask is being worn by a user (10);

drawing air into and out of an air chamber (13) of the mask using the inhalation and exhalation fans (14, 15);

detecting an inhalation and an exhalation of the user;

determining whether the user is inhaling or exhaling; and

increasing a rotation speed of the inhalation fan (14) relative to a rotation speed of the exhalation fan (15) at the start of inhalation, and

increasing the rotation speed of the exhalation fan (15) relative to the rotation speed of the inhalation fan (14) at the start of exhalation.

40 Patentansprüche

1. Maske (11), umfassend:

eine Luftkammer (13);

ein Filter (12);

einen Einatemungsventilator (14) zum Ansaugen von Luft durch den Filter von außerhalb der Luftkammer (13) in die Luftkammer (13);

einen Ausatemungsventilator (15) zum Ansaugen von Luft aus dem Inneren der Luftkammer (13) nach außen;

einen Sensor (22) zum Erfassen eines Einatmens und Ausatmens eines Benutzers (10); und

eine Steuerung (20), die angepasst ist, zum:

kontinuierliches Betreiben des Einatemungsventilators (14) und des Ausatemungsventilators

- (15), wenn die Maske vom Benutzer getragen wird.
über den Sensor (22) Feststellen, ob der Benutzer ein- oder ausatmet; und
Erhöhen einer Drehzahl des Einatemventilators (14) relativ zu einer Drehzahl des Ausatemventilators (15) zu Beginn des Einatmens, und
Erhöhen der Drehzahl des Ausatemventilators (15) relativ zur Drehzahl des Einatemventilators (14) zu Beginn des Ausatmens.
2. Maske nach Anspruch 1, wobei der Sensor (22) einen Differenzdrucksensor zum Bestimmen einer Druckdifferenz zwischen Luft außerhalb der Luftkammer (13) und Luft innerhalb der Luftkammer (13) umfasst.
3. Maske nach einem der vorhergehenden Ansprüche, wobei die Drehzahl durch ein Impulsbreitenmodulationssignal gesteuert wird.
4. Maske nach einem der vorhergehenden Ansprüche, wobei die Einatem- und Ausatemventilatoren (14, 15) von elektronisch kommutierten bürstenlosen Motoren angetrieben werden.
5. Maske nach einem der vorhergehenden Ansprüche, wobei der Einatemventilator (14) eine erste Drehzahl und eine zweite Drehzahl aufweist, und der Ausatemventilator (15) eine erste Drehzahl und eine zweite Drehzahl aufweist, und die zweite Drehzahl beider Lüfter höher ist als die erste Drehzahl beider Lüfter.
6. Maske nach Anspruch 5, wobei die erste Drehzahl beider Lüfter 10 bis 500 U/min beträgt.
7. Maske nach Anspruch 5 oder 6, wobei die zweite Drehzahl beider Lüfter 5- bis 50-mal höher ist als die erste Drehzahl beider Lüfter.
8. Maske nach einem der Ansprüche 5 bis 7, wobei die erste Drehzahl des Einatemventilators (14) dieselbe ist wie die erste Drehzahl des Ausatemventilators (15) .
9. Maske nach einem der vorhergehenden Ansprüche, wobei die Maske ferner einen Schalter zum Starten und Stoppen der Einatem- und Ausatemventilatoren (14, 15) umfasst.
10. Maske nach einem der vorhergehenden Ansprüche, wobei der Filter (12) eine Außenwand der Luftkammer (13) oder ein Filterelement in Reihe mit dem Einatemventilator (14) umfasst.
11. Verfahren zum Steuern der Maske (11) nach einem

der vorhergehenden Ansprüche, umfassend:

kontinuierliches Betreiben eines Einatemventilators (14) und eines Ausatemventilators (15), wenn die Maske von einem Benutzer (10) getragen wird;
Ansaugen von Luft in und aus einer Luftkammer (13) der Maske unter Verwendung der Einatem- und Ausatemventilatoren (14, 15);
Erfassen eines Einatmens und eines Ausatmens des Benutzers;
Bestimmen, ob der Benutzer ein- oder ausatmet; und
Erhöhen einer Drehzahl des Einatemventilators (14) relativ zu einer Rotationsgeschwindigkeit des Ausatemventilators (15) zu Beginn des Einatmens, und
Erhöhen der Drehzahl des Ausatemventilators (15) relativ zur Drehzahl des Einatemventilators (14) zu Beginn des Ausatmens.

Revendications

1. Masque (11) comprenant:

une chambre à air (13);
un filtre (12);
un ventilateur d'inspiration (14) pour aspirer de l'air à travers le filtre depuis l'extérieur de la chambre à air (13) dans la chambre à air (13);
un ventilateur d'expiration (15) pour aspirer de l'air de l'intérieur de la chambre à air (13) vers l'extérieur;
un capteur (22) pour détecter une inspiration et une expiration d'un utilisateur (10); et

un dispositif de commande (20) qui est adapté pour:

faire fonctionner en continu le ventilateur d'inspiration (14) et le ventilateur d'expiration (15) lorsque le masque est porté par l'utilisateur;
déterminer via le capteur (22) si l'utilisateur inspire ou expire; et
augmenter une vitesse de rotation du ventilateur d'inspiration (14) par rapport à une vitesse de rotation du ventilateur d'expiration (15) au début de l'inspiration, et
augmenter la vitesse de rotation du ventilateur d'expiration (15) par rapport à la vitesse de rotation du ventilateur d'inspiration (14) au début de l'expiration.

2. Masque selon la revendication 1, dans lequel le capteur (22) comprend un capteur de pression différentiel pour déterminer une différence de pression entre l'air à l'extérieur de la chambre à air (13) et l'air à l'intérieur de la chambre à air (13).

3. Masque selon l'une quelconque des revendications précédentes, dans lequel la vitesse de rotation est commandée par un signal de modulation de largeur d'impulsion. 5
4. Masque selon l'une quelconque des revendications précédentes, dans lequel les ventilateurs d'inspiration et d'expiration (14, 15) sont entraînés par des moteurs sans balais à commutation électronique. 10
5. Masque selon l'une quelconque des revendications précédentes, dans lequel le ventilateur d'inspiration (14) a une première vitesse de rotation et une seconde vitesse de rotation, et le ventilateur d'expiration (15) a une première vitesse de rotation et une seconde vitesse de rotation, et la seconde vitesse de rotation des deux ventilateurs est supérieure à la première vitesse de rotation des deux ventilateurs. 15
6. Masque selon la revendication 5, dans lequel la première vitesse de rotation des deux ventilateurs est de 10 à 500 tr/min. 20
7. Masque selon la revendication 5 ou 6, dans lequel la seconde vitesse de rotation des deux ventilateurs est 5 à 50 fois supérieure à la première vitesse de rotation des deux ventilateurs. 25
8. Masque selon l'une quelconque des revendications 5 à 7, dans lequel la première vitesse de rotation du ventilateur d'inspiration (14) est la même que la première vitesse de rotation du ventilateur d'expiration (15). 30
9. Masque selon l'une quelconque des revendications précédentes, dans lequel le masque comprend en outre un interrupteur pour démarrer et arrêter les ventilateurs d'inspiration et d'expiration (14, 15). 35
10. Masque selon l'une quelconque des revendications précédentes, dans lequel le filtre (12) comprend une paroi externe de la chambre à air (13), ou un élément de filtre en série avec le ventilateur d'inspiration (14). 40
11. Procédé de commande du masque (11) selon l'une quelconque des revendications précédentes, consistant à : 45
- faire fonctionner en continu un ventilateur d'inspiration (14) et un ventilateur d'expiration (15) lorsque le masque est porté par un utilisateur (10); 50
 - aspirer de l'air dans et hors d'une chambre à air (13) du masque en utilisant les ventilateurs d'inspiration et d'expiration (14, 15); 55
 - détecter une inspiration et une expiration de l'utilisateur;
- déterminer si l'utilisateur inspire ou expire; et augmenter une vitesse de rotation du ventilateur d'inspiration (14) par rapport à une vitesse de rotation du ventilateur d'expiration (15) au début de l'inspiration, et augmenter la vitesse de rotation du ventilateur d'expiration (15) par rapport à la vitesse de rotation du ventilateur d'inspiration (14) au début de l'expiration.

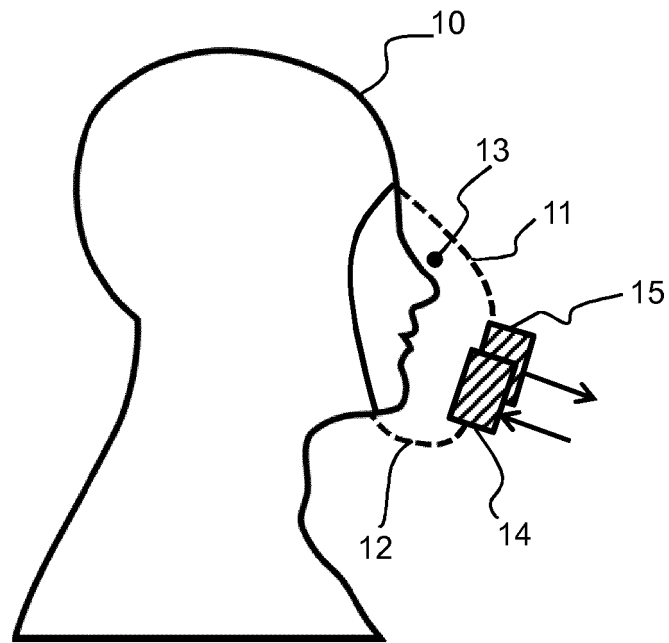

FIG. 1

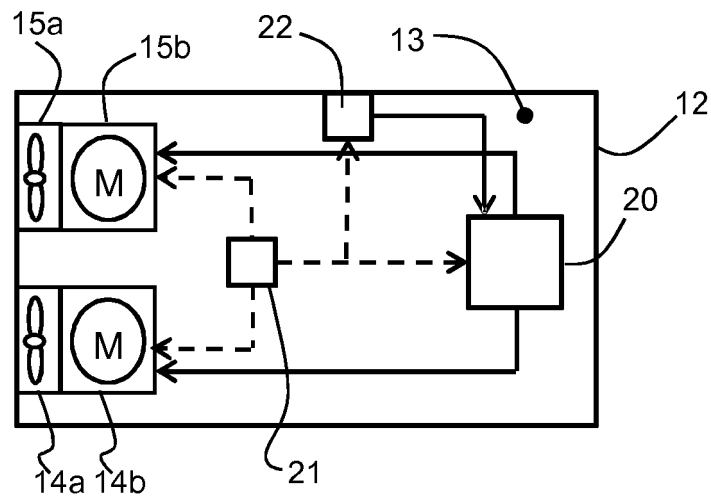

FIG. 2

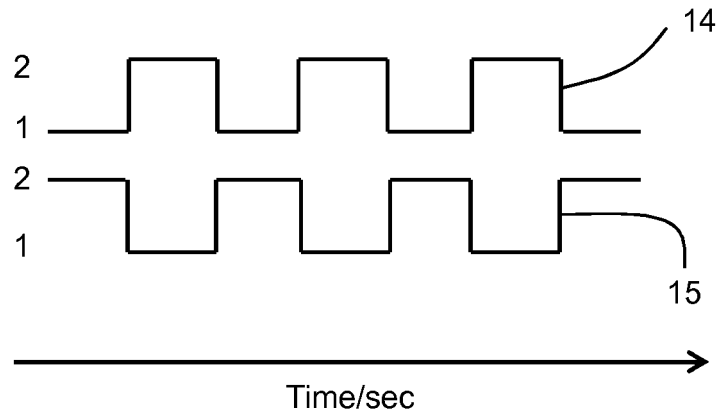

FIG. 3

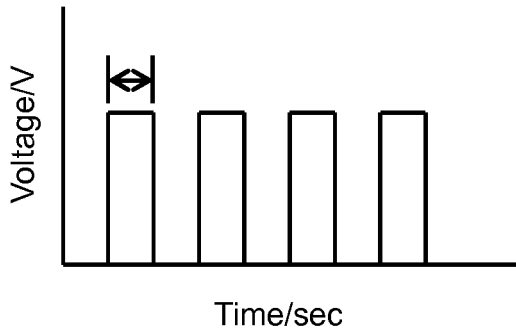

FIG. 4a

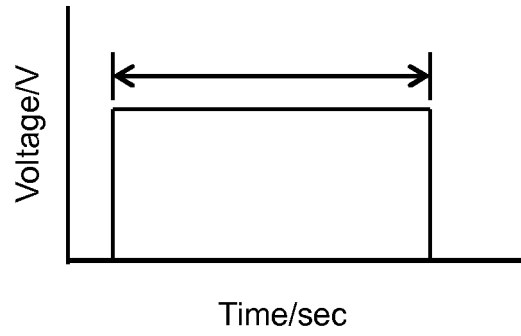

FIG. 4b

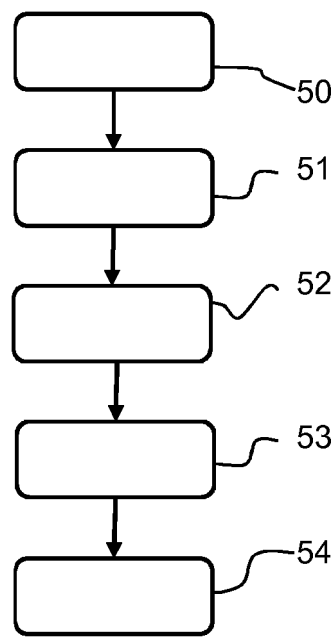

FIG. 5

REFERENCES CITED IN THE DESCRIPTION

This list of references cited by the applicant is for the reader's convenience only. It does not form part of the European patent document. Even though great care has been taken in compiling the references, errors or omissions cannot be excluded and the EPO disclaims all liability in this regard.

Patent documents cited in the description

- GB 2032284 A [0009]
- WO 2016157159 A [0010]
- CN 104548406 [0011]
- JP 2008295993 A [0012]