



(51) International Patent Classification:

H02G 1/00 (2006.01) *H01R 43/28* (2006.01)
G01B 7/12 (2006.01) *H02G 1/12* (2006.01)
H01B 13/00 (2006.01)

(21) International Application Number:

PCT/IB2020/059792

(22) International Filing Date:

18 October 2020 (18.10.2020)

(25) Filing Language:

English

(26) Publication Language:

English

(30) Priority Data:

16/657,539 18 October 2019 (18.10.2019) US

(71) Applicant: **TE CONNECTIVITY SERVICES GMBH**
[CH/CH]; Rheinstrasse 20, 8200 Schaffhausen (CH).

(72) Inventors: **HOUSER, Matthew Steven**; 2901 Fulling Mill Road, Middletown, 17057 (US). **DECK, Gary**; 2901 Fulling Mill Road, Middletown, Pennsylvania 17057 (US). **MORRIS, Michael**; 2901 Fulling Mill Road, Middletown, Pennsylvania 17057 (US).

(81) Designated States (unless otherwise indicated, for every kind of national protection available): AE, AG, AL, AM, AO, AT, AU, AZ, BA, BB, BG, BH, BN, BR, BW, BY, BZ, CA, CH, CL, CN, CO, CR, CU, CZ, DE, DJ, DK, DM, DO,

DZ, EC, EE, EG, ES, FI, GB, GD, GE, GH, GM, GT, HN, HR, HU, ID, IL, IN, IR, IS, IT, JO, JP, KE, KG, KH, KN, KP, KR, KW, KZ, LA, LC, LK, LR, LS, LU, LY, MA, MD, ME, MG, MK, MN, MW, MX, MY, MZ, NA, NG, NI, NO, NZ, OM, PA, PE, PG, PH, PL, PT, QA, RO, RS, RU, RW, SA, SC, SD, SE, SG, SK, SL, ST, SV, SY, TH, TJ, TM, TN, TR, TT, TZ, UA, UG, US, UZ, VC, VN, WS, ZA, ZM, ZW.

(84) Designated States (unless otherwise indicated, for every kind of regional protection available): ARIPO (BW, GH, GM, KE, LR, LS, MW, MZ, NA, RW, SD, SL, ST, SZ, TZ, UG, ZM, ZW), Eurasian (AM, AZ, BY, KG, KZ, RU, TJ, TM), European (AL, AT, BE, BG, CH, CY, CZ, DE, DK, EE, ES, FI, FR, GB, GR, HR, HU, IE, IS, IT, LT, LU, LV, MC, MK, MT, NL, NO, PL, PT, RO, RS, SE, SI, SK, SM, TR), OAPI (BF, BJ, CF, CG, CI, CM, GA, GN, GQ, GW, KM, ML, MR, NE, SN, TD, TG).

Published:

- with international search report (Art. 21(3))
- in black and white; the international application as filed contained color or greyscale and is available for download from PATENTSCOPE

(54) Title: CABLE END SENSING APPARATUS AND METHOD

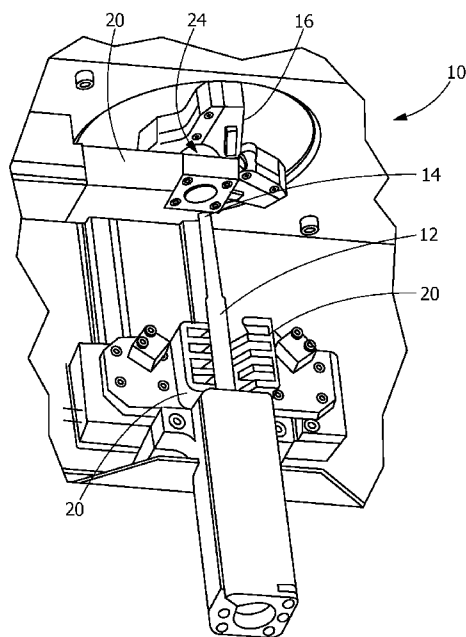

FIG. 1

(57) Abstract: A cable end sensing apparatus (10) and a method of sensing a cable end (14) of a cable (12) in a cable preparation device (16). The cable end sensing apparatus (10) includes cable clamps (20) for clamping and moving the cable (12) and a movable sensing device (24). The movable sensing device (24) has a first position in which the movable sensing device (24) is positioned in line with an axis of insertion (26) of the cable (12) to engage the end (14) of the cable (12) and to prevent the cable (12) from moving beyond the movable sensing device (24). The movable sensing device (24) has a second position in which the movable sensing device (24) is moved away from the axis of insertion (26) of the cable (12) when the cable end (14) is properly positioned to allow the cable (12) to move beyond the sensing device (24).



CABLE END SENSING APPARATUS AND METHOD

[0001] Devices that facilitate positioning cables in a cable preparation device are known. Various existing machines use only a hard stop to locate the cable end. This method relies on the operator placing the cable correctly in the machine every time, which introduces the risk of user error. Also, this method does not ensure the cable did not move during the preparation process.

[0002] The problem to be solved is to provide a cable end sensing apparatus that accurately positions the end of the cable before beginning the cable preparation cycle and checks for proper cable position after completion of the cycle, thereby ensuring proper strip or cut lengths on the cable.

[0003] This problem is solved by providing a sensing method which uses a sensing device to check the cable position before beginning the cycle, and later uses the same sensing device to check the cable position after completing the cycle, thereby ensuring proper strip or cut lengths on the cable.

[0004] An embodiment is directed to a method of sensing a cable end of a cable in a cable preparation device. The method includes: positioning the cable end of the cable in engagement with a sensing device; detecting the cable end with the sensing device; clamping cable with cable clamps; detecting with the sensing device if the cable end remains in engagement with the sensing device after the cable is clamped; moving the cable end toward the sensing device if the cable end is not detected by the sensing device; and moving the sensing device away from an axis of insertion of the cable to allow the cable to enter the cable preparation device.

[0005] The invention will now be described by way of example with reference to the accompanying drawings in which:

[0006] FIG. 1 is a perspective view of an illustrative cable end sensing apparatus according to the present invention.

[0007] FIG. 2 is a top diagrammatic view of a cable inserted into the cable end sensing apparatus.

[0008] FIG. 3 is a top diagrammatic view of the cable inserted into the cable end sensing apparatus, with the cable clamp gripping the cable.

[0009] FIG. 4 is a top diagrammatic view of the cable clamp moving the cable toward a sensing plate of the cable end sensing apparatus, whereby the end of the cable is in contact with a sensing plate.

[0010] FIG. 5 is a top diagrammatic view showing the sensing plate moved from the path of the cable.

[0011] FIG. 6 is a top diagrammatic view of the end of the cable inserted into a cable preparation mechanism.

[0012] FIG. 7 is a top diagrammatic view of the cable clamp and the cable being retracted from the cable preparation mechanism to expose the stripped end of the cable.

[0013] FIG. 8 is a top diagrammatic view showing the sensing plate moved back into the path of the cable.

[0014] FIG. 9 is a top diagrammatic view of the cable clamp moving the stripped cable end back toward the sensing plate, whereby the stripped end of the cable is in contact with the sensing plate.

[0015] FIG. 10 is a top diagrammatic view of the stripped cable released from the cable clamp.

[0016] FIG. 11 is a front perspective view of an alternate illustrative embodiment of the sensing device of the cable end sensing apparatus.

[0017] As shown in FIG. 1, a cable end sensing apparatus 10 is provided to detect or sense an end 14 of a cable 12 to ensure proper positioning of the cable 12 in a cable preparation device 16. A factor in the preparation of the

cable 12 is the strip or cut lengths of different parts (i.e. outer jacket, braid and inner jacket) of the cable 12. The strip or cut lengths of the different parts require a level of precision so that further cable processing steps, such as, but not limited to, termination, can be performed to specification. The cable end sensing apparatus 10 allows for the precise positioning of the cable 12 prior to the cable 12 being inserted into the cable preparation device 12. In addition, the use of the cable end sensing apparatus 10 allows for quicker machine loading of the cable 12 because it requires less precision on the part of the operator.

[0018] As shown in the FIGS. 2 through 10, the cable end sensing apparatus has a pair of cable clamps 20, an inner guard 22 and a sensing device 24. In the illustrative embodiment shown, the cable clamps 20 are driven by a pneumatic device (not shown). However, the cable clamps 20 may be driven by spring force or other types of closing forces. The inner guard 22 is a safety device which prevents the operator from making contact with the cable preparation device 16. The inner guard 22 is optional and may have many different configurations without departing from the scope of the invention.

[0019] In the illustrative embodiment, the sensing device 24 is a sensing plate which detects changes in capacitance of the cable 12 to determine whether or not the cable 12 is contacting the sensing device 24. The sensing device 24 is movable in a direction which is perpendicular to an axis 26 of insertion of the cable 12 to allow the cable 12 to be moved into the cable preparation device 16. However, other configurations and motions of the sensing device 24 may be used. In the illustrative embodiment shown, the sensing device 24 is driven by a pneumatic device (not shown). However, the sensing device 24 may be moved using other drive mechanisms.

[0020] In the initial position, as shown in FIG. 2, the cable clamps 20 are in the open position and the sensing device 24 is positioned in a first position in which the sensing device 24 is in line with the axis 26 of insertion of the cable 12 into the cable preparation device 16. When in the open position, the cable 12 is

inserted between the cable clamps 20. Insertion continues until the end 14 of the cable 12 engages a surface 28 of the sensing device 24 causing a hard stop of the cable 12 in the direction 30 of insertion. In this position, the sensing device 24 also acts as a guard to prevent the operator or the cable 12 from moving past the sensing device 24 and improperly entering or engaging the cable preparation device 16.

[0021] With the cable end 14 positioned in engagement with the surface 28 of the sensing device 24, the sensing device detects the cable end 14 and the cable clamps 20 are moved, as indicated by arrows 32 in FIG. 3, into engagement with the cable 12 to provide a secure grip between the cable clamps 20 and the cable 12.

[0022] Once the cable 12 is secured by the cable clamps 20, if the sensing device 24 detects that the cable end 14 remains in engagement with the surface 28 of the sensing device 24, the sensing device 24 is moved as shown in FIG. 5, as will be more fully described. If the cable end 14 is not detected by the sensing device 24 after the cable 12 is clamped, the cable clamps 20 and the cable 12 are moved toward the surface 28 of the sensing device 24, as indicated by arrow 34 of FIG. 4. This movement occurs until the sensing device 24 detects the cable end 14 in engagement with the surface 28.

[0023] The sensing device 24 acts as a hard stop that detects changes in capacitance of the cable 12 to determine whether or not the cable 12 is contacting the sensing device 24 or hard stop. If the cable 12 is not contacting the sensing device 24, the cable clamps 20 advance the cable 12 until the cable end 14 is detected by the sensing device 24. As the cable end sensing apparatus 10 facilitates the proper positioning of the cable end 14, this allows for less precise cable loading by the operator.

[0024] If the sensing device 24 does not detect the cable end 14 with a certain predetermined distance, the sensing device 24 of the cable end sensing

apparatus 10 will enter a fault state and alert the operator that there is an issue with the cable 12 location.

[0025] If the cable end 14 is detected by the sensing device 24, the sensing device 24 provides a signal that the cable preparation process may proceed. This causes the sensing device 24 to move perpendicular to the axis 26 of insertion of the cable 12. The movement continues, as shown by the arrow 36 in FIG. 5, until the sensing device 24 is moved to a second position in which the sensing device 24 is moved away from the axis 26 to allow the cable end 14 of the cable 12 to move beyond the sensing device 24 and enter the cable preparation device 16.

[0026] With the sensing device 24 moved from the axis 26 of insertion, the cable clamps 20 and cable 12 are moved in the direction of arrow 38 in FIG. 6, toward the cable preparation device 16. This movement continues until the cable end 14 of the cable 12 is positioned in the cable preparation device 16. With the cable end 14 positioned in the cable preparation device 16, the cable preparation device 16 prepares the cable end 14 as required.

[0027] With the cable end 14 properly prepared by the cable preparation device 16, the cable clamps 20 and cable 12 are retracted and moved in the direction of arrow 40 in FIG. 7. This movement is continued until the cable end 14 is moved past the plane of the sensing device 24. The sensing device 24 is then moved perpendicular to the axis 26 of insertion of the cable 12, as indicated by arrow 42 of FIG. 8, back to its original position. The sensing device 24 is moved to be in line with the axis 26, thereby preventing the cable end 14 of the cable 12 from entering the cable preparation device 16.

[0028] With the sensing device 24 properly positioned, the cable clamps 20 and cable 12 are advanced and moved toward the sensing device, as shown by the arrow 44 in FIG. 9. This movement occurs until the sensing device 24 detects the cable end 14 in engagement with the surface 28.

[0029] If the sensing device 24 does not detect the cable end 14 with a certain predetermined distance, the sensing device 24 of the cable end sensing apparatus 10 will enter a fault state and alert the operator that there is an issue with the cable preparation process.

[0030] If the cable end 14 is detected within an acceptable range of its initial position by the sensing device 24, the sensing device 24 provides a signal that the cable 12 did not move within the cable clamps 20 during the cable preparation process, allowing the cable clamps 20 to move away from the cable 12, as shown by the arrow 46 in FIG 10. As this occurs, the cable 12 is released to be moved from the cable end sensing apparatus 10 to the next station.

[0031] As shown in FIG. 11, the sensing device 24 may include a sensing target zone 50 on the surface 28 of the sensing device 24. The sensing target zone 50 can be used to ensure the cable 12 is centered in the cable end sensing apparatus 10 before the preparation process described above begins. If the cable 12 is not centered, the sensing device 24 of the cable end sensing apparatus 10 will enter a fault state and alert the operator that there is an issue with the positioning of the cable 12.

[0032] As shown in FIG. 11, the target zone 50 of the sensing device 24 may include separate, sensing zones, such as, but not limited to, concentric sensing rings 52 to determine the diameter of the cable 12 to ensure that the proper size of cable 12 is used before the preparation process described above begins. In other embodiments, the target zone 50 is grid or an array of sensing zones. If an improper sized cable 12 is positioned in the cable end sensing apparatus 10, the sensing device 24 will enter a fault state and alert the operator that there is an issue with the size of the cable 12.

[0033] The sensed capacitive value of the cable 12 as determined by the sensing device 24 may be compared to the known capacitive value of a known or ideal cable to determine whether the cable 12 is of an appropriate length and/or diameter. If the sensing device 24 senses an improper capacitive value

of the cable 12, as compared to the known or ideal cable, the sensing device 24 will enter a fault state and alert the operator that there is an issue with the cable 12.

[0034] While the embodiment described herein have sensing devices 24 which detect changes in capacitance, other types of sensing devices may be used. For example, the sensing devices may use other cable end sensing technologies, such as resistive sensing or a mechanical switch to perform the same tasks described above.

[0035] CLAIMS

1. A method of sensing a cable end (14) of a cable (12) in a cable preparation device (16), the method comprising:
 - positioning the cable end (14) of the cable (12) in engagement with a sensing device (24);
 - detecting the cable end (14) with the sensing device (24);
 - clamping the cable (12) with cable clamps (20);
 - detecting with the sensing device (24) if the cable end (14) remains in engagement with the sensing device (24) after the cable (12) is clamped;
 - moving the cable end (14) toward the sensing device (24) if the cable end (14) is not detected by the sensing device (24); and
 - moving the sensing device (24) away from an axis of insertion (26) of the cable (12) to allow the cable (12) to enter the cable preparation device (16).
2. The method as recited in claim 1, wherein if the sensing device (24) does not detect the cable end (14) with a certain predetermined distance after the cable (12) is clamped, the sensing device (24) will enter a fault state and alert an operator that there is an issue with the cable (12) location.
3. The method as recited in claim 1, wherein the sensing device (24) is moved perpendicular to the axis of insertion (26) of the cable (12).
4. The method as recited in claim 1, comprising:
 - with the sensing device (24) moved from the axis of insertion (26), moving the cable clamps (20) and cable (12) in the direction toward the cable preparation device (16) until the cable end (14) of the cable (12) is positioned in the cable preparation device (16);
 - preparing the cable end (14) in the cable preparation device (16).
5. The method as recited in claim 4, comprising:
 - with the cable end (14) properly prepared by the cable preparation device (16), the cable clamps (20) and cable (12) are

retracted until the cable end (14) is moved past a plane of the sensing device (24);

moving the sensing device (24) perpendicular to the axis of insertion (26) of the cable (12), wherein the sensing device (24) is moved to be in line with the axis of insertion (26), thereby preventing the cable end (14) of the cable (12) from entering the cable preparation device (16).

6. The method as recited in claim 5, comprising:
 - with the sensing device (24) properly positioned, the cable clamps (20) and cable (12) are advanced and moved toward the sensing device (24);
 - detecting the cable end (14) is in engagement with the surface (28) of the sensing device (24).
7. The method as recited in claim 6 wherein if the sensing device (24) does not detect the cable end (14) with a certain predetermined distance, the sensing device (24) will enter a fault state and alert the operator that there is an issue with the cable preparation process.
8. The method as recited in claim 6 wherein if the cable end (14) is detected within an acceptable range of its initial position by the sensing device (24), the sensing device (24) provides a signal that the cable (12) did not move within the cable clamps (20) during the cable preparation process, allowing the cable clamps (20) to move away from the cable (12).
9. The method as recited in claim 1 wherein the sensing device (24) has a sensing target zone (50) on the surface (28) of the sensing device (24), the sensing target zone (50) ensures the cable (12) is centered in the cable end (14) sensing apparatus.
10. The method as recited in claim 9 wherein if the cable (12) is not centered, the sensing device (24) will enter a fault state and alert the operator that there is an issue with the positioning of the cable (12).

11. The method as recited in claim 9 wherein the sensing target zone (50) has sensing zones (52) to determine the diameter of the cable (12) to ensure that the proper size of cable (12) is used before the preparation process begins.
12. The method as recited in claim 11 wherein if an improper sized cable (12) is positioned in the cable end (14) sensing apparatus, the sensing device (24) will enter a fault state and alert the operator that there is an issue with the size of the cable (12).
13. The method as recited in claim 1 wherein the sensing device (24) is a sensing plate which detects changes in capacitance to determine whether or not the cable (12) is contacting the sensing device (24).
14. The method as recited in claim 13 wherein a sensed capacitive value of the cable (12) as determined by the sensing device (24) is compared to a known capacitive value to determine whether the cable (12) is of an appropriate length and/or diameter.
15. The method as recited in claim 14 wherein if the sensing device (24) senses an improper capacitive value of the cable (12), the sensing device (24) will enter a fault state and alert the operator that there is an issue with the cable (12).

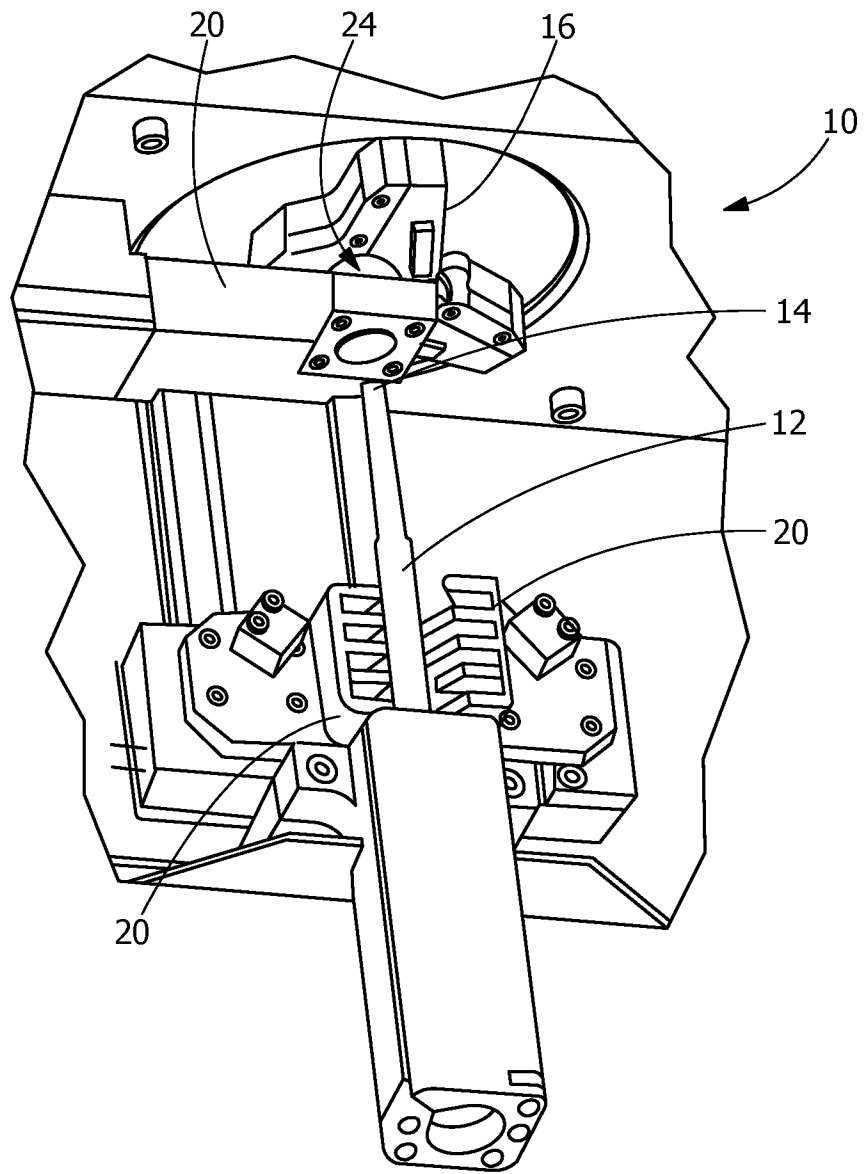

FIG. 1

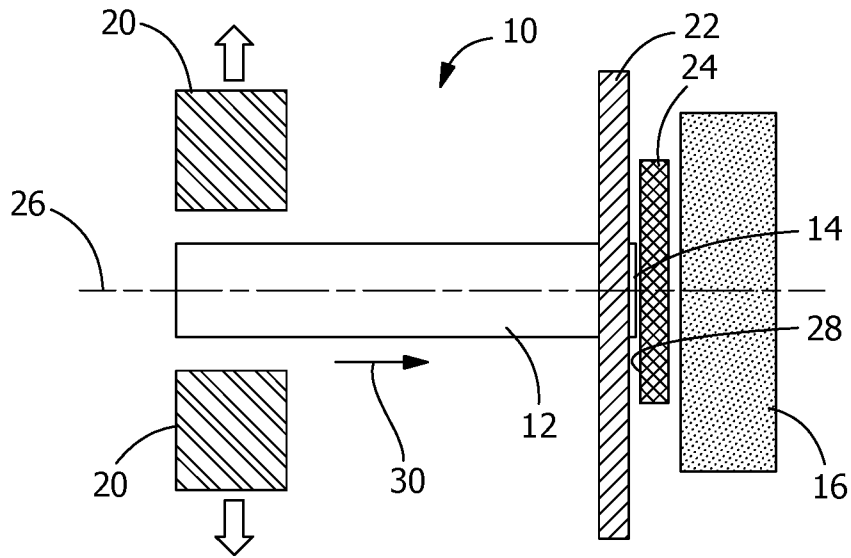

FIG. 2

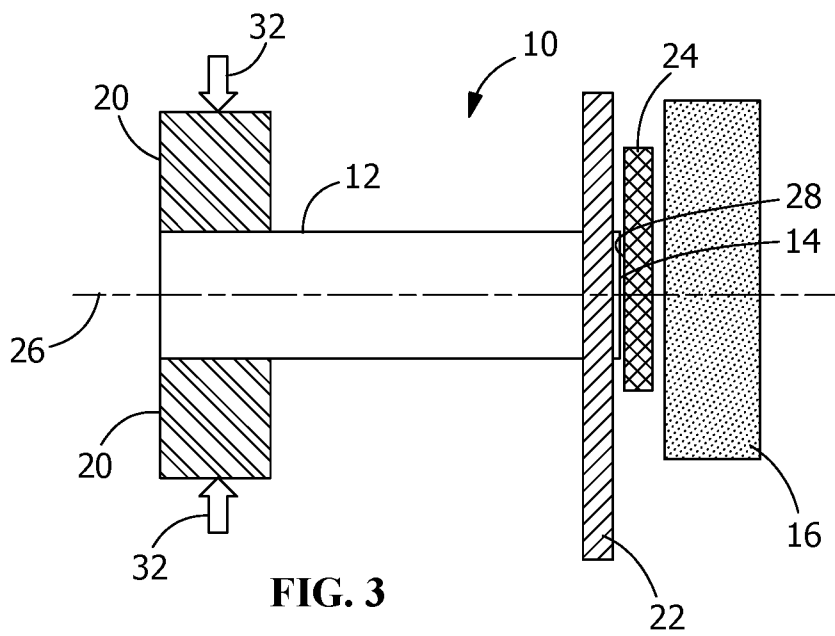

FIG. 3

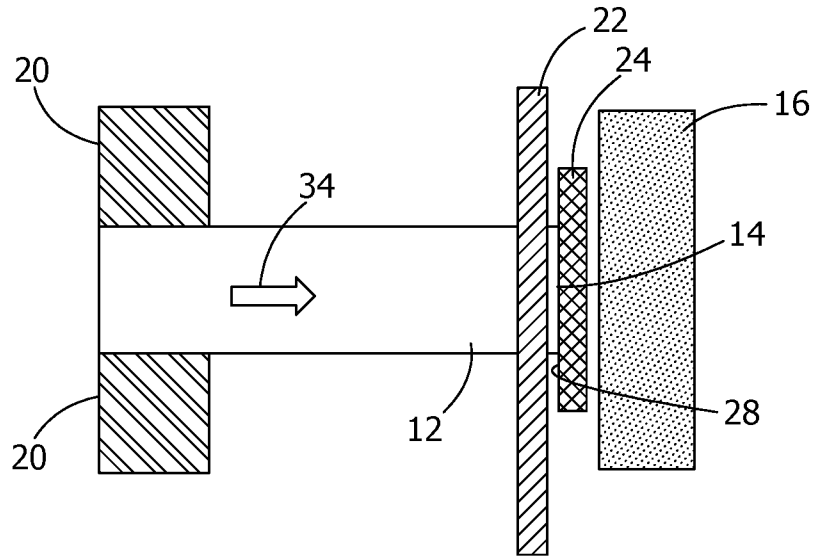

FIG. 4

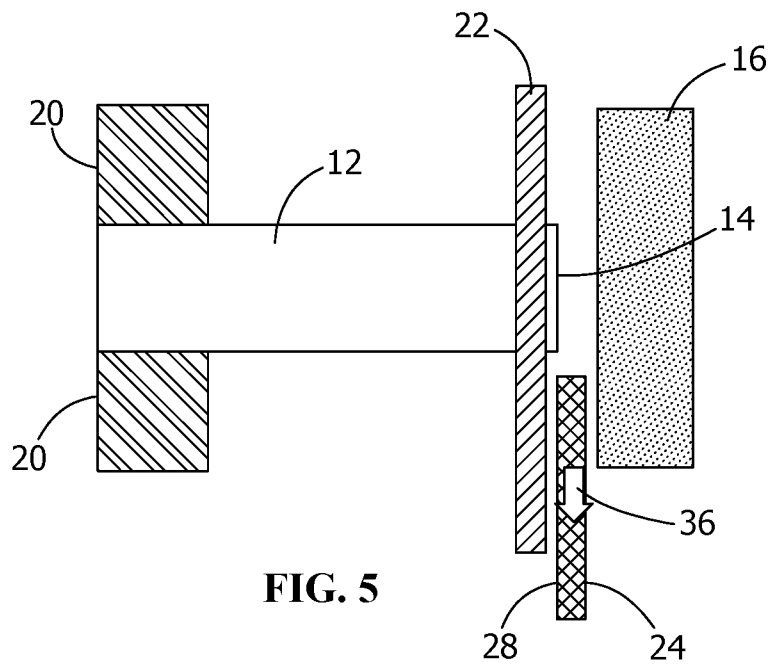

FIG. 5

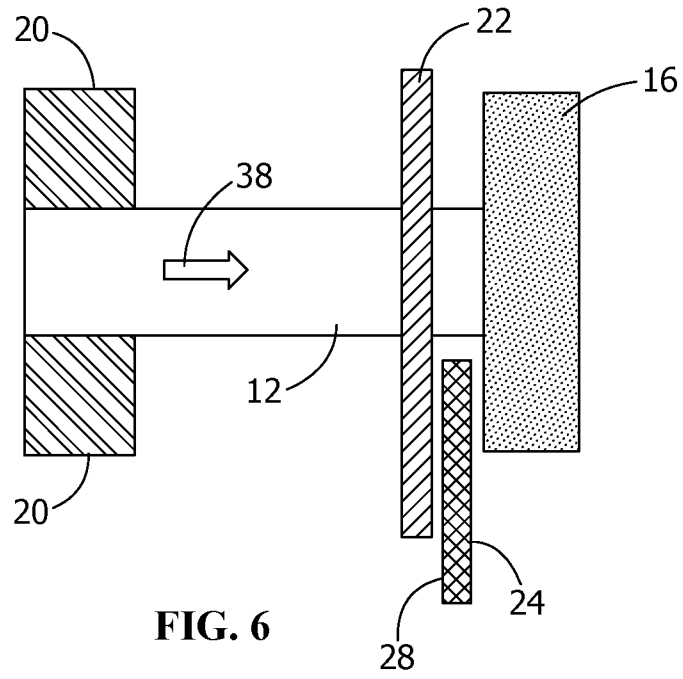

FIG. 6

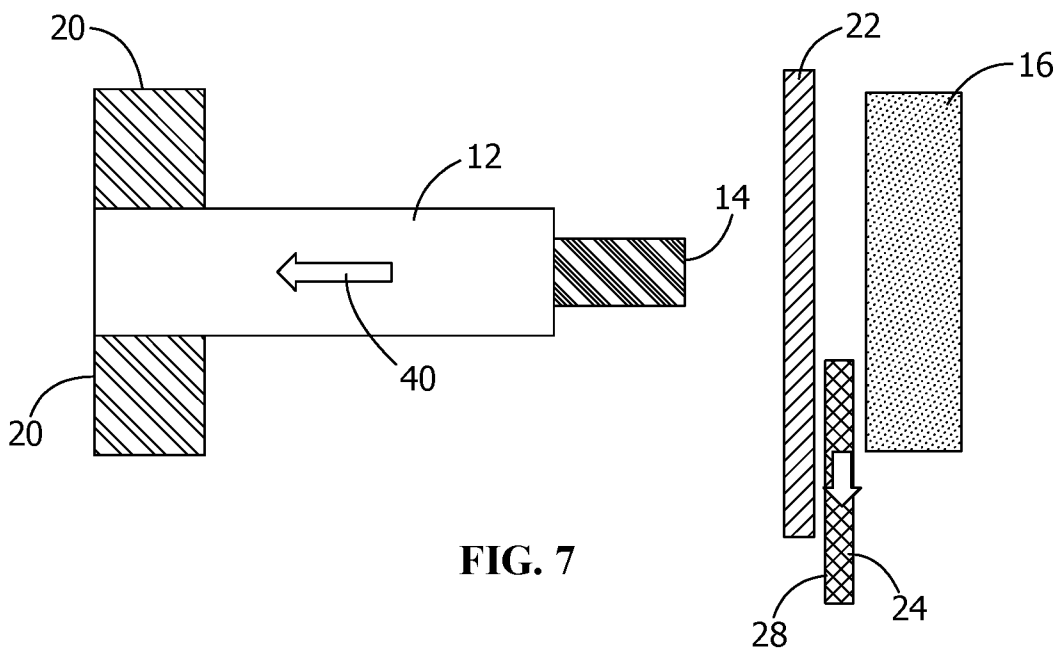
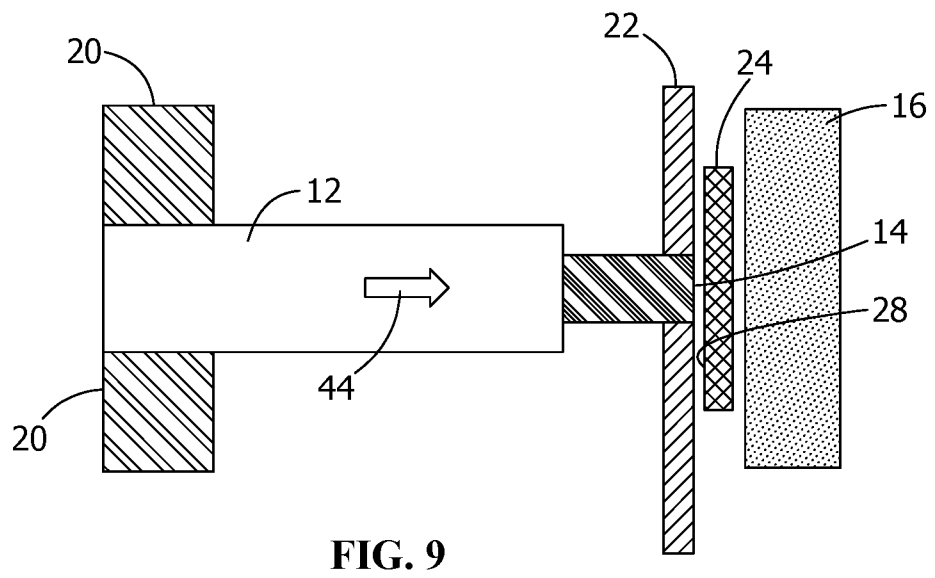
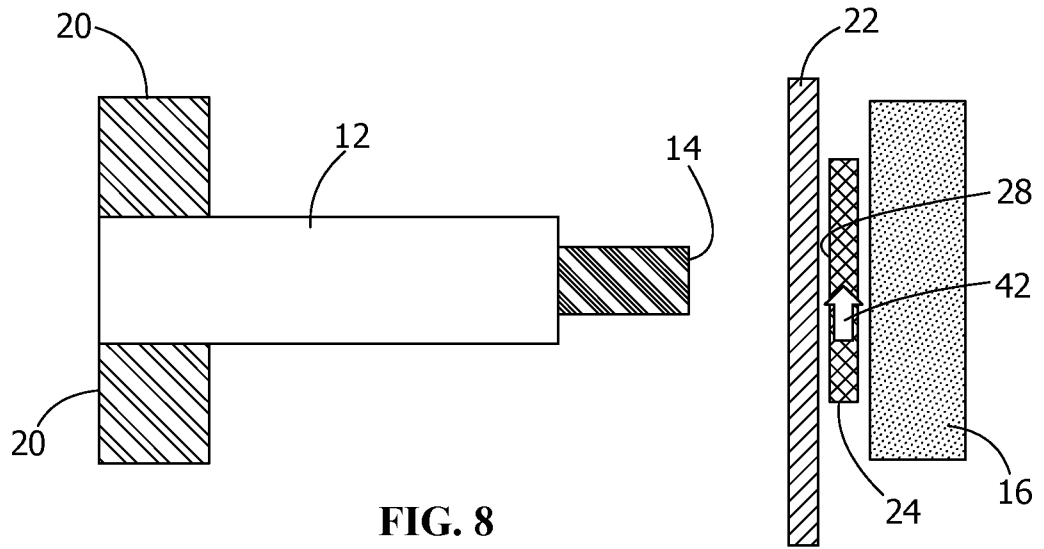

FIG. 7



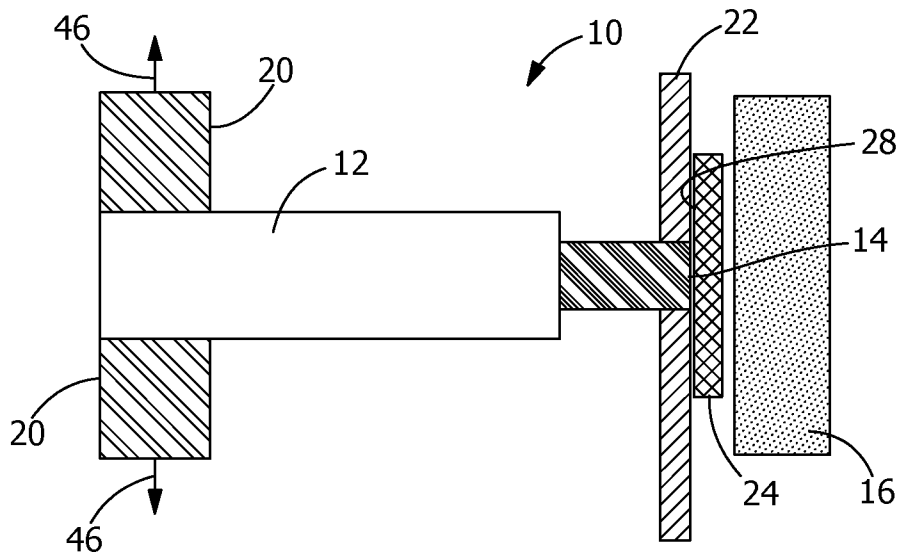

FIG. 10

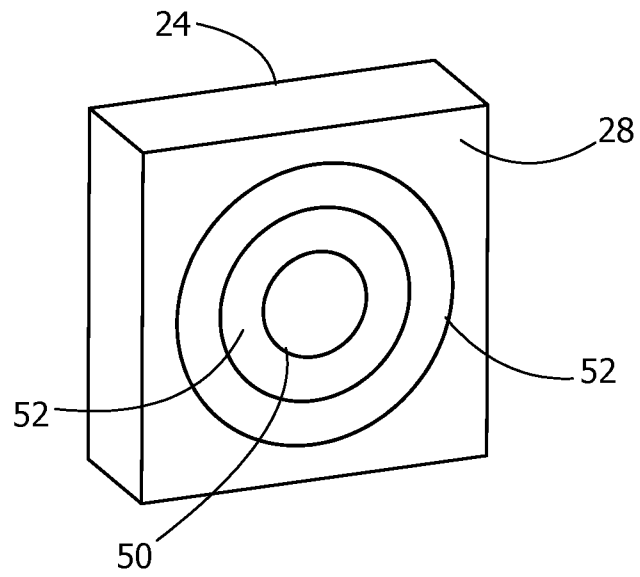

FIG. 11

INTERNATIONAL SEARCH REPORT

International application No
PCT/IB2020/059792

A. CLASSIFICATION OF SUBJECT MATTER
 INV. H02G1/00 G01B7/12 H01B13/00 H01R43/28
 ADD. H02G1/12

According to International Patent Classification (IPC) or to both national classification and IPC

B. FIELDS SEARCHED

Minimum documentation searched (classification system followed by classification symbols)
 H02G G01B H01B H01R

Documentation searched other than minimum documentation to the extent that such documents are included in the fields searched

Electronic data base consulted during the international search (name of data base and, where practicable, search terms used)
 EPO-Internal, WPI Data

C. DOCUMENTS CONSIDERED TO BE RELEVANT

Category*	Citation of document, with indication, where appropriate, of the relevant passages	Relevant to claim No.
X	US 2007/169339 A1 (MATSUOKA MASAKI [JP]) 26 July 2007 (2007-07-26)	1-10
A	paragraphs [0001], [0007], [0031], [0034], [0036] - [0038], [0040]; figure 1	11-15
A	----- JP 2001 357960 A (YAZAKI CORP) 26 December 2001 (2001-12-26) paragraph [0015]; figure 3	1-15
A	----- US 4 850 221 A (ZIELKE HENRY [US]) 25 July 1989 (1989-07-25) the whole document	1-15

Further documents are listed in the continuation of Box C.

See patent family annex.

* Special categories of cited documents :

- "A" document defining the general state of the art which is not considered to be of particular relevance
- "E" earlier application or patent but published on or after the international filing date
- "L" document which may throw doubts on priority claim(s) or which is cited to establish the publication date of another citation or other special reason (as specified)
- "O" document referring to an oral disclosure, use, exhibition or other means
- "P" document published prior to the international filing date but later than the priority date claimed

"T" later document published after the international filing date or priority date and not in conflict with the application but cited to understand the principle or theory underlying the invention

"X" document of particular relevance; the claimed invention cannot be considered novel or cannot be considered to involve an inventive step when the document is taken alone

"Y" document of particular relevance; the claimed invention cannot be considered to involve an inventive step when the document is combined with one or more other such documents, such combination being obvious to a person skilled in the art

"&" document member of the same patent family

Date of the actual completion of the international search	Date of mailing of the international search report
15 January 2021	26/01/2021

Name and mailing address of the ISA/ European Patent Office, P.B. 5818 Patentlaan 2 NL - 2280 HV Rijswijk Tel. (+31-70) 340-2040, Fax: (+31-70) 340-3016	Authorized officer Hestroffer, Karine
--	--

INTERNATIONAL SEARCH REPORT

Information on patent family members

International application No

PCT/IB2020/059792

Patent document cited in search report	Publication date	Patent family member(s)	Publication date	
US 2007169339	A1	26-07-2007	CH 696508 A5	13-07-2007
			CN 101009417 A	01-08-2007
			JP 4413872 B2	10-02-2010
			JP 2007202272 A	09-08-2007
			US 2007169339 A1	26-07-2007

JP 2001357960	A	26-12-2001	JP 3803013 B2	02-08-2006
			JP 2001357960 A	26-12-2001

US 4850221	A	25-07-1989	EP 0358509 A1	14-03-1990
			JP H0682048 B2	19-10-1994
			JP H02176412 A	09-07-1990
			US 4850221 A	25-07-1989
