

(Model.)

2 Sheets—Sheet 1.

C. H. REMINGTON.

PLOW.

No. 251,287.

Patented Dec. 20, 1881.

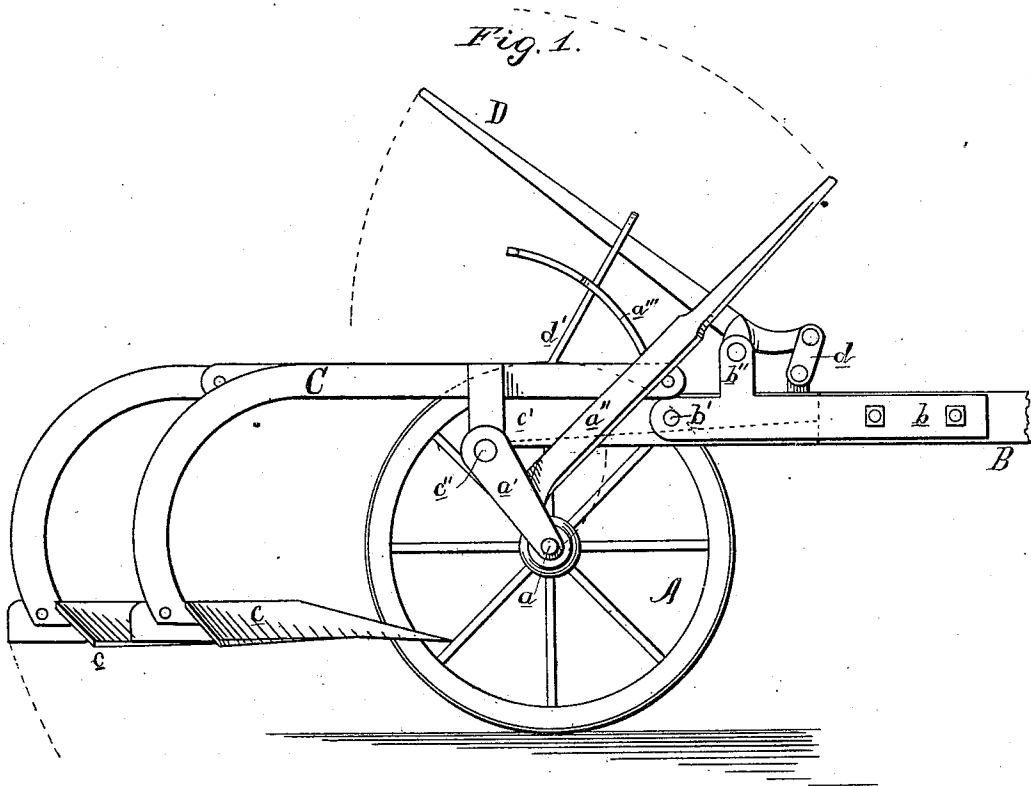

Witnesses:

J. W. Garner
H. S. D. Haines

Inventor:
Charles H. Remington,
by Howard A. Ginn,
Attorney.

(Model.)

2 Sheets—Sheet 2.

C. H. REMINGTON.

PLOW.

No. 251,287.

Patented Dec. 20, 1881.

Fig. 2.

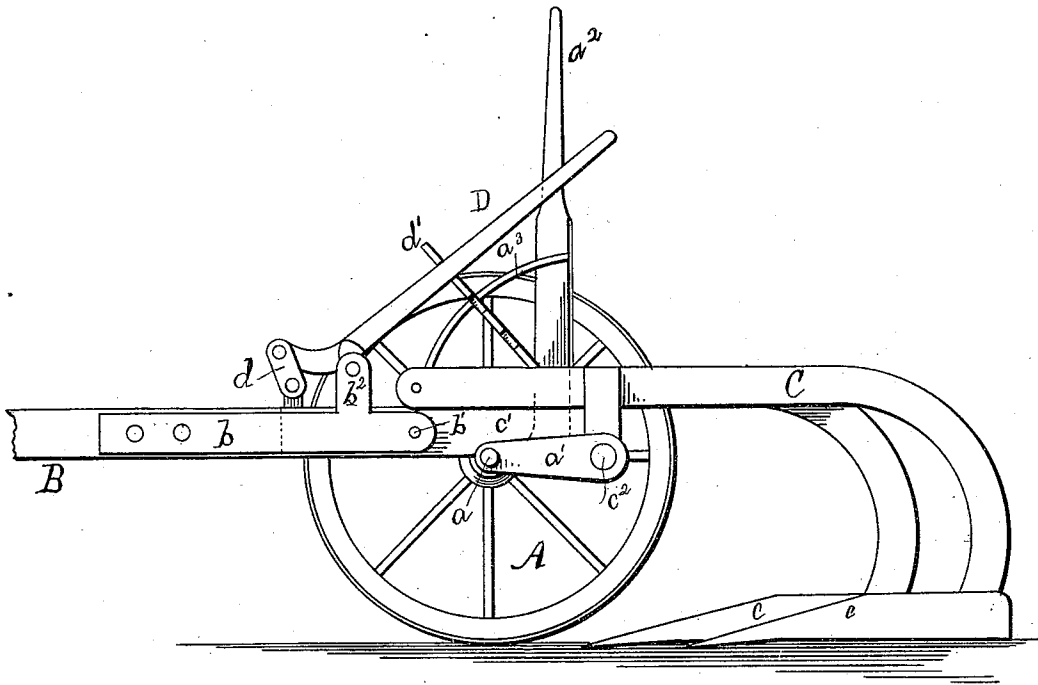
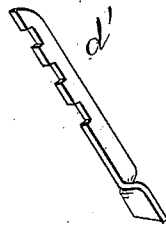

Fig. 3.



Witnesses:

J. W. Garner.
W. S. D. Haines.

Inventor:
Charles H. Remington.
by *Howard A. Snow,*
Attorney.

UNITED STATES PATENT OFFICE.

CHARLES H. REMINGTON, OF GILROY, CALIFORNIA.

PLOW.

SPECIFICATION forming part of Letters Patent No. 251,287, dated December 20, 1881.

Application filed July 29, 1881. (Model.)

To all whom it may concern:

Be it known that I, CHARLES H. REMINGTON, a citizen of the United States of America, residing at Gilroy, in the county of Santa Clara and State of California, have invented certain new and useful Improvements in Plows; and I do hereby declare the following to be a full, clear, and exact description of the invention, such as will enable others skilled in the art to which it appertains to make and use the same, reference being had to the accompanying drawings, and to letters or figures of reference marked thereon, which form a part of this specification.

My invention relates to an improvement in plows, and has for its object the construction of a plow the points of which can be easily elevated when coming in contact with or to pass over an obstruction.

In the drawings, Figure 1 is a side view of my invention, one wheel being removed for convenience in showing the device. Fig. 2 is a view of the plow from the opposite side to Fig. 1; and Fig. 3 is a view of the toothed rack, upon which ranges one of the plow-levers.

The wheels A are placed upon the axle *a* in the ordinary manner. They are connected with the plow-beam by the crank *a'*, to which is fastened the lever *a''*, moving upon the toothed rack *a'''*, and by means of which the wheels may be raised or lowered to plow at required depths.

B is the tongue. To its lower end is bolted the iron plates *b*, which extend back and are hinged at *b'* to the supplementary plow-beam *c'*, as shown. On the top of the plates *b* are formed the projections *b''*, to which are pivoted the lever D.

C is the plow-beam, to which is attached the plows *c*. It is hinged to the crank *a'* by the pinions *c''*, and is provided with a supplement-

ary beam, *c'*, to the top of which it is securely fastened, as shown.

D is the lever for raising or lowering the plow-points. It is hinged to the projections *b'* on the plates *b*, and is connected to the supplementary beam *c'* by the links *d*, as shown. The lever ranges upon the toothed rack *d'*, as shown.

The operation of my plow is as follows: The plows are set to the required depth by the lever *a''*. When an obstruction is reached, by depressing the lever D the supplementary beam *c'* will be raised, which will in turn elevate the plow-points. In the drawings the plows are shown clear of the ground, and when an obstruction of unusual size is reached, by bringing the plows to the position shown and also depressing the lever D, a very advantageous elevation can be secured. After an ordinary obstruction is passed, for which it is not necessary to alter the lever *a''*, the lever D can be again elevated and the work continued without further trouble.

Having described my invention, what I claim, and desire to secure by Letters Patent, is—

The combination of the tongue B, having fastened to its inner end the plates *b*, pivoted at *b'* to the supplementary beam *c'*, and having formed upon them lugs or projections *b''*, with the supplementary beam *c'*, to which is securely attached the beam C, and the lever D, pivoted to the lugs *b''* and to the supplementary beam *c'*, and ranging upon the toothed rack *d'*, substantially as described and set forth.

In testimony whereof I have affixed my signature in presence of two witnesses.

CHARLES HASKIN REMINGTON.

Witnesses:

GEO. E. HERSEY,
E. H. FARMER.