

A. B. CARLL.
 BARREL FILLER.
 APPLICATION FILED SEPT. 21, 1910.

1,001,249.

Patented Aug. 22, 1911.

2 SHEETS—SHEET 1.

Fig. 1.

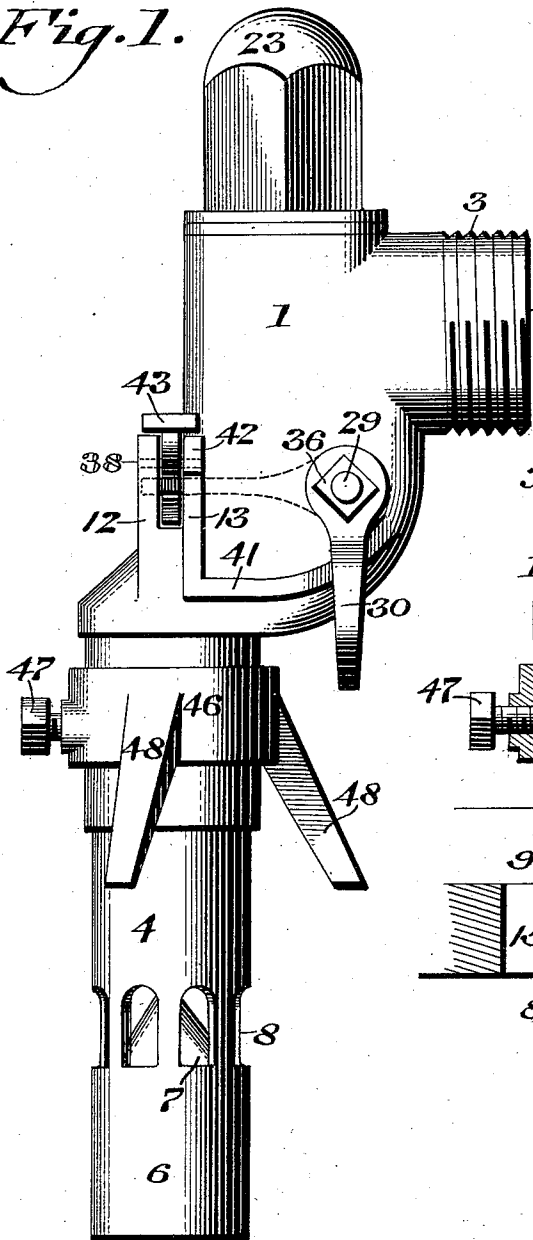
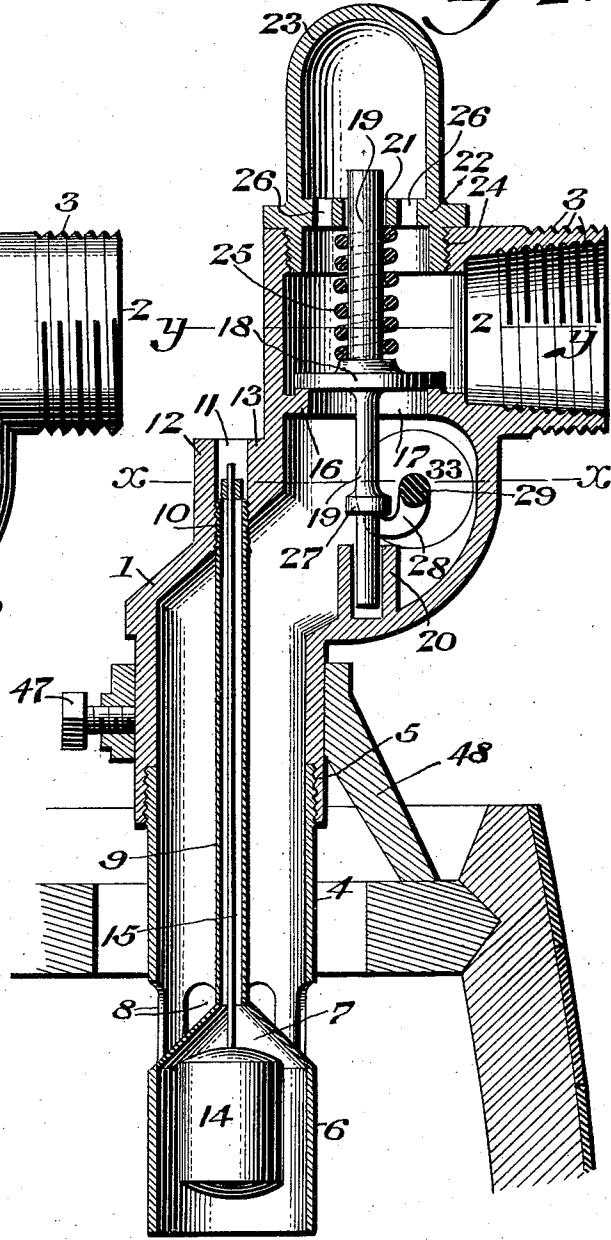

Fig. 2.



WITNESSES

P. F. Nagle.
H. G. Dieterich

INVENTOR

Addison B. Carll.
 BY *Wiederheim & Traub*
 ATTORNEYS

Fig. 3.

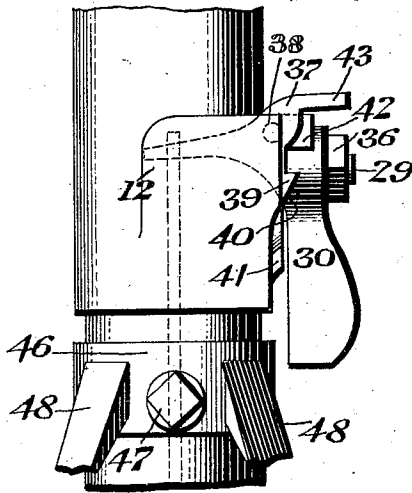

Fig. 4.

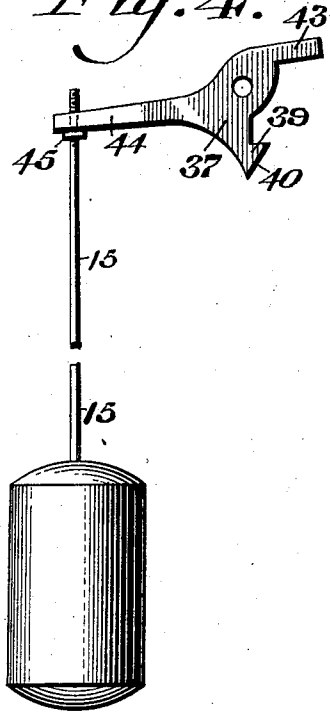

Fig. 5.

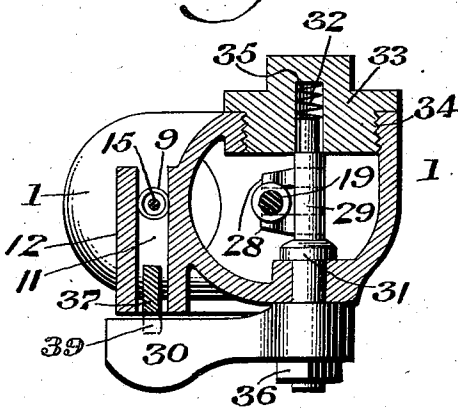
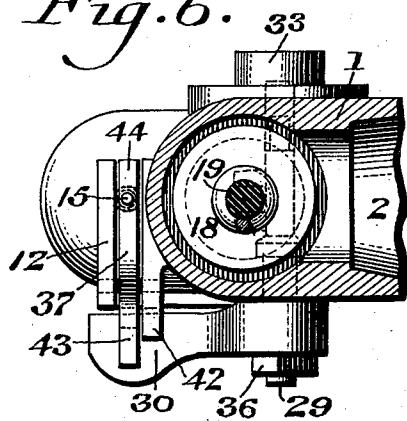

Fig. 6.



WITNESSES
P. F. Nagel.
H. G. Dietsch

INVENTOR
Addison B. Carll.
 BY *Wiederheim & Fairbanks*
 ATTORNEYS

UNITED STATES PATENT OFFICE.

ADDISON B. CARLL, OF JACKSONVILLE, FLORIDA.

BARREL-FILLER.

1,001,249.

Specification of Letters Patent. Patented Aug. 22, 1911.

Application filed September 21, 1910. Serial No. 583,012.

To all whom it may concern:

Be it known that I, ADDISON B. CARLL, a citizen of the United States, residing at Jacksonville, in the county of Duval, State of Florida, have invented a new and useful Barrel-Filler, of which the following is a specification.

This invention relates to a receptacle filling mechanism and more particularly to the type known as a barrel filler, whereby flow of a liquid is properly directed into a barrel or the like, and when the receptacle is filled, the mechanism operates automatically to cut off the supply of liquid, thereby preventing overflow and obviating the necessity of some one standing near to watch the filling operation.

In barrel fillers as heretofore constructed it has been found in practice that the valve mechanisms do not operate positively and accurately, either failing to close at the proper time or else closing too soon from a slight jar caused by rolling barrels along the floor of the building. It has also been found that the mechanism is too light and delicate for ordinary use and the fillers soon break and get out of order.

In my present invention I have devised a complete unitary valve structure wherein the valve co-acts with a suitable operating mechanism during an opening movement of the valve, but during its return or closing movement is independent of the said operating mechanism and therefore as soon as released, the valve snaps to its seat and effectively cuts off the fluid supply and wherein all the parts are strong and durable and the opening operation is simple and automatically held.

It further consists of other novel features of construction, all as will be hereinafter fully set forth.

For the purpose of illustrating my invention, I have shown in the accompanying drawings one form thereof which is at present preferred by me, since the same has been found in practice to give satisfactory and reliable results, although it is to be understood that the various instrumentalities of which my invention consists can be variously arranged and organized and that my invention is not limited to the precise

arrangement and organization of these instrumentalities as herein shown and described.

Figure 1 represents a side elevation of a filling device embodying my invention. Fig. 2 represents a vertical section of the same. Fig. 3 represents a front elevation of a portion of Fig. 1. Fig. 4 represents certain detached portions showing the operation of the front mechanism. Fig. 5 represents a section on line $x-x$, Fig. 2. Fig. 6 represents a section on line $y-y$, Fig. 2.

Similar numerals of reference indicate corresponding parts in the figures.

Referring to the drawings:—1 designates the casing of my novel filling device, the same being provided with an inlet opening 2 which is preferably provided with threads 3 whereby a suitable fitting may be attached thereto as may be desired.

4 designates an outlet nozzle, in the present instance, detachably secured to the casing 1 by means of threads 5 or like fastening means, the said nozzle 4 terminating in a chamber 6 having a partition 7 secured thereto and serving to separate the chamber 6 from the interior of the nozzle 4. Adjacent this partition 7 are a plurality of outlet openings 8 which serve to permit liquid to pass therethrough around the outside of the chamber 6 into the barrel. It will be noted that the partition 7 is preferably cone-shaped and has secured adjacent the apex thereof a tubular member 9, which passes interiorly of the casing 1 and has, as here shown, screw threaded engagement at 10 with the walls thereof. The casing 1 has, adjacent this point, a recess 11 formed by projecting walls 12 and 13, the said recess 11 serving to accommodate certain adjuncts of the tripping mechanism, hereinafter described. The tubular member 9 forms, with the chamber 6, an inclosing means and guide for a float 14 and its rod 15, whereby the fluid passing through the casing does not come into contact therewith.

16 designates a partition formed within the casing 1 and having an opening therein through which the fluid from the inlet 2 is adapted to pass, the said opening 17 being provided with a suitable valve 18 which seats upon the partition 16, as will be

apparent. This valve 18 is fixedly secured to a spindle 19 intermediate the ends thereof, one end of said spindle being guided in a suitable bearing 20 formed in the casing 1, while the opposite end projects through an opening 21 in the base 22 of an air chamber or cap 23 having screw threaded engagement at 24 with the casing 1. The valve 18 is maintained in normally closed position through the medium of a spring 25 encircling the spindle 19, said spring of course operating to seat the valve after it has been mechanically opened.

26 designates suitable ports leading into the air chamber 23, the function of which will readily be apparent.

27 designates a collar suitably secured to the spindle 19 and forming a shoulder with which a bifurcated lever 28 is adapted to cooperate and raise the valve 18 from its seat at the desired time. This lever 28 is fixedly secured to a spindle 29 suitably journaled crosswise in the casing 1 and having an end projecting exteriorly thereof in order to receive a crank arm 30 serving as an operating means for manually controlling the valve opening operation.

It will be noted that the spindle 29 is provided with a collar 31 which normally contacts with the wall of the casing 1, so that there is no leakage at this point and the said collar is maintained firmly pressed against its seat through the medium of the spring 32, one end of which engages the end of the spindle 29, while the other end contacts with the cap 33, this latter being threaded at 34 into the casing 1. It will be noted that the cap 33 is suitably bored at 35 to receive the end of the spindle 29 and the spring 32. Any well known means may be utilized for maintaining the crank arm 30 on the spindle 29 in order that the two parts rotate together and I have here shown them in threaded engagement and held by the nut 36.

It will be noted in normally closed position of the valve 18 that the arm 30 is vertically disposed, as shown in Fig. 1, and should it be desired to open the valve 18, the arm 30 is turned to the dotted line position indicated in Fig. 1 and maintained in such position with the valve open by means of a trip and lock mechanism, now to be described. This mechanism consists of a dog 37, suitably pivoted at 38 within the wall extensions 12 and 13, and provided with a lug 39 normally projecting into the path of movement of the arm 30 and vertically below the pivot 38. As the arm 30 is raised from the vertical to the horizontal position, it contacts with an inclined face 40 of the lug 39, thereby shifting the dog 37 on its pivot to permit the arm 30 to pass beyond the lug 39, whereupon the dog 37 swings back, by gravity, bringing the lug 39 beneath the arm 30 and maintains it in its raised horizontal position

It will be noted that it is preferable to have a rib 41 secured to or integral with the casing 1, the said rib forming a guide to properly direct the arm 30. The movement of the arm 30 is limited by a stop 42 forming a part of the wall 13.

43 designates a finger formed integral with the dog 37, whereby the same may be manually manipulated to release the parts.

44 designates an extension formed integral with the dog 37 and suitably connected with the rod 15 of the float lever 14, said connection in the present instance, consisting of a thread and nut connection 45, as will be apparent.

46 designates a collar adapted to fit over the outlet portion of the casing 1 and being detachably or adjustably secured thereto by means of a suitable set screw 47 or like device, said collar having preferably formed integral therewith outwardly extending lugs 48 which serve as legs or supports for engaging the barrel or receptacle to which the device is adapted to be attached, it of course being understood that the outlet nozzle 4 is passed through a suitable opening in the receptacle and the legs 48 thus come in contact with the outside wall of the receptacle and support the filler.

In the operation of the device the nozzle 4 is placed through a suitable opening in the receptacle and the legs 48 brought into contact with the outside thereof, thus supporting the device in upright and operative position ready to admit fluid to the casing. The operator then shifts the arm 30 from vertical position to the horizontal dotted line position as shown in Fig. 1, passing the said arm above the lug 39, which latter then adjusts itself beneath the arm, thus locking the parts in filling position, while the weight of the float 14 normally holds the lug 39 outwardly extended. The movement of the arm 30 to the position just described causes rotation of the spindle 29, thus swinging the bifurcated lever 28 into engagement with the collar 27, thus raising the valve 18 from its seat and overcoming the pressure of the spring 25. In this position of the parts fluid enters the inlet opening 12, passes through the partition 16 by way of the port 17 and thus into the barrel through the outlet openings 8. It will be noted that none of the liquid during a filling operation comes into contact with the float 14 or other parts of the tripping mechanism.

As soon as the barrel or like receptacle has been filled to the proper height, the float 14 is raised, thus shifting the dog 37 about the pivot 38 and removing the lug 39 beneath the arm 30. The arm 30 being preferably provided with a weighted end, acts quickly under gravity and drops to vertical position, thereby removing the bifurcated lever 28 from supporting position

beneath the collar 27, whereupon the spring 26 snaps the valve 18 closed and shuts off the supply of fluid.

In Fig. 2 a portion of a barrel 49 is shown in order to illustrate the attached position of the filler and show the parts in operative relation to the barrel.

Attention is directed to the feature of providing an air chamber adjacent to the valve 18. The air in this chamber forms a cushion for the column of liquid and prevents hammering when the valve closes.

I am aware that it has heretofore been proposed in the patent to Babbitt No. 517,136, March 27, 1894, to employ a spring-operated valve in combination with certain automatically operating mechanism, the same consisting of many parts dependent upon the spring to effect proper operation. It is, however, desirable in the commercial manufacture and practical use of devices of this character, that the parts be made simple and strong and constructed in such a manner that they may be readily operated by unskilled labor without undue manipulation or a multiplicity of parts. My present invention is clearly differentiated from the Babbitt device aforesaid, as will be apparent to those skilled in the art, since the same has a spindle with arms which engage a lug on the lower side of the valve spindle, this spindle extending crosswise of the device back to the valve rod and being short, well

supported and strong. It will also be apparent that the position of the opening lever upon the side of the device and the position and shape of the locking dog are entirely different from any device hitherto made.

Having thus described my invention, what I claim as new and desire to secure by Letters Patent, is:

In a device of the character stated, a casing having an inlet and an outlet, a valve between said inlet and outlet, a valve stem secured to each side of said valve, guide means for each stem, a lug secured to one of said stems, a spring encircling the other stem and adapted to maintain said valve normally closed, a spindle journaled in said casing and independently operable with respect to said valve, means carried by said spindle adapted to engage said lug in one direction of movement of said spindle, whereby said valve is opened, an arm exterior of said casing fixedly secured to said spindle, a dog pivoted in said casing and adapted to lock said arm in open position of said valve, and a float actuated mechanism cooperating with said dog whereby said arm is released and returns by gravity and spring pressure to normal position.

ADDISON B. CARLL.

Witnesses:

ROBERT L. BUCKMAN,
M. E. KIMBALL.