

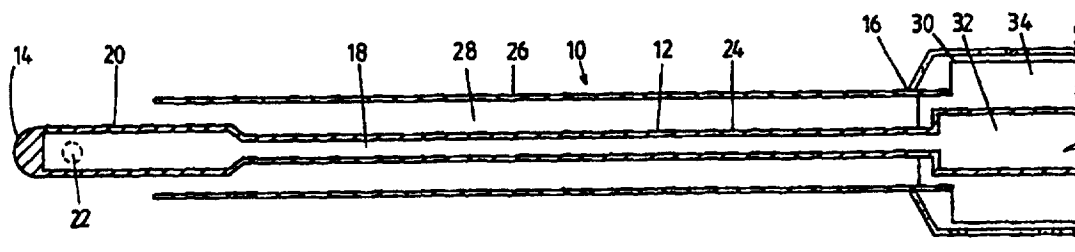

## INTERNATIONAL APPLICATION PUBLISHED UNDER THE PATENT COOPERATION TREATY (PCT)

(51) International Patent Classification <sup>6</sup> : <b>A61F 9/007</b>	<b>A1</b>	(11) International Publication Number: <b>WO 98/07398</b> (43) International Publication Date: 26 February 1998 (26.02.98)
<p>(21) International Application Number: PCT/AU97/00536</p> <p>(22) International Filing Date: 22 August 1997 (22.08.97)</p> <p>(30) Priority Data: PO 1787                      22 August 1996 (22.08.96)                      AU</p> <p>(71) Applicant (for all designated States except US): OVERSBY PTY. LTD. [AU/AU]; Level 1, 10 Kings Park Road, West Perth, W.A. 6005 (AU).</p> <p>(72) Inventor; and (75) Inventor/Applicant (for US only): BARRETT, Graham, David [AU/AU]; 56 Dampier Avenue, City Beach, W.A. 6015 (AU).</p> <p>(74) Agent: LORD, Kelvin, Ernest; Lord &amp; Company, 4 Douro Place, West Perth, W.A. 6005 (AU).</p>	<p>(81) Designated States: AL, AM, AT, AU, AZ, BA, BB, BG, BR, BY, CA, CH, CN, CU, CZ, DE, DK, EE, ES, FI, GB, GE, GH, HU, IL, IS, JP, KE, KG, KP, KR, KZ, LC, LK, LR, LS, LT, LU, LV, MD, MG, MK, MN, MW, MX, NO, NZ, PL, PT, RO, RU, SD, SE, SG, SI, SK, SL, TJ, TM, TR, TT, UA, UG, US, UZ, VN, YU, ZW, ARIPO patent (GH, KE, LS, MW, SD, SZ, UG, ZW), Eurasian patent (AM, AZ, BY, KG, KZ, MD, RU, TJ, TM), European patent (AT, BE, CH, DE, DK, ES, FI, FR, GB, GR, IE, IT, LU, MC, NL, PT, SE), OAPI patent (BF, BJ, CF, CG, CI, CM, GA, GN, ML, MR, NE, SN, TD, TG).</p> <p><b>Published</b> <i>With international search report.</i></p>	

(54) Title: INTRAOCULAR IRRIGATION/ASPIRATION DEVICE



## (57) Abstract

An intraocular irrigation/aspiration device (10) including a hollow shaft (12) with a distal tip portion (20) and a proximal portion (24). The shaft (12) includes a lumen (18) extending through the shaft (12) wherein the lumen (18) is of reduced cross-sectional area in the proximal portion (24) so as to regulate aspiration of fluid and reduce post occlusion surge phenomena. Preferably, the device (10) includes an outer sleeve (26) which is flexible so as to enable a small incision in the eye to engage closely with the shaft (12).

**FOR THE PURPOSES OF INFORMATION ONLY**

Codes used to identify States party to the PCT on the front pages of pamphlets publishing international applications under the PCT.

AL	Albania	ES	Spain	LS	Lesotho	SI	Slovenia
AM	Armenia	FI	Finland	LT	Lithuania	SK	Slovakia
AT	Austria	FR	France	LU	Luxembourg	SN	Senegal
AU	Australia	GA	Gabon	LV	Latvia	SZ	Swaziland
AZ	Azerbaijan	GB	United Kingdom	MC	Monaco	TD	Chad
BA	Bosnia and Herzegovina	GE	Georgia	MD	Republic of Moldova	TG	Togo
BB	Barbados	GH	Ghana	MG	Madagascar	TJ	Tajikistan
BE	Belgium	GN	Guinea	MK	The former Yugoslav Republic of Macedonia	TM	Turkmenistan
BF	Burkina Faso	GR	Greece			TR	Turkey
BG	Bulgaria	HU	Hungary	ML	Mali	TT	Trinidad and Tobago
BJ	Benin	IE	Ireland	MN	Mongolia	UA	Ukraine
BR	Brazil	IL	Israel	MR	Mauritania	UG	Uganda
BY	Belarus	IS	Iceland	MW	Malawi	US	United States of America
CA	Canada	IT	Italy	MX	Mexico	UZ	Uzbekistan
CF	Central African Republic	JP	Japan	NE	Niger	VN	Viet Nam
CG	Congo	KE	Kenya	NL	Netherlands	YU	Yugoslavia
CH	Switzerland	KG	Kyrgyzstan	NO	Norway	ZW	Zimbabwe
CI	Côte d'Ivoire	KP	Democratic People's Republic of Korea	NZ	New Zealand		
CM	Cameroon			PL	Poland		
CN	China	KR	Republic of Korea	PT	Portugal		
CU	Cuba	KZ	Kazakistan	RO	Romania		
CZ	Czech Republic	LC	Saint Lucia	RU	Russian Federation		
DE	Germany	LI	Liechtenstein	SD	Sudan		
DK	Denmark	LK	Sri Lanka	SE	Sweden		
EE	Estonia	LR	Liberia	SG	Singapore		

INTRAOCULAR IRRIGATION / ASPIRATION DEVICEFIELD OF INVENTION

The present invention relates generally to intraocular irrigation/aspiration devices.

5

BACKGROUND OF THE INVENTION

Occurrence of the disease known as cataracts, in which the lens of the eye becomes clouded, is common, and can lead to blindness. It has become accepted practice to alleviate this condition by surgically removing the cataract-affected lens and replacing it  
10 by an artificial intraocular lens.

The cataract-affected lens is usually removed by manual extraction or phaco-emulsification. Manual extraction requires expression of the nucleus of the lens through a wound of about 12mm in length. The residual peripheral lens material is then removed  
15 by an intraocular irrigation/aspiration device.

The technique known as phaco-emulsification, as described, for example, in US Patent 3,589,363, enables removal of the cataract-affected lens through a much smaller incision of about 2.5 - 4mm, for example, 3.2 mm. This is accomplished using high frequency  
20 ultrasound energy, typically of 40 kHz frequency, that is transmitted by a phaco-emulsification needle to fragment or emulsify the nucleus of the cataract-affected lens. Once fragmented or emulsified, the nuclear material is aspirated through a lumen of the phaco-emulsification needle.

25 An improved phaco-emulsification needle is also described and claimed in International Patent Application No PCT/AU95/00558 in the name of the present applicant.

After the nuclear material of the lens has been aspirated or emulsified by use of the phaco-emulsification needle and aspirated through a lumen thereof, there remains in the  
30 eye residual lens material which is derived from softer lens material which originally

surrounded the nucleus.

After treatment with the phaco-emulsification needle it is necessary to remove the residual lens material by means of an intraocular irrigation/aspiration device. This device  
5 includes a tip which is inserted through the incision in the eye. The tip includes a small opening at its distal end which opening is about 0.3mm in dimension. A lumen leads from the opening through the device to an aspiration device. Further, the device includes an outer sleeve which extends to a point adjacent to the tip to form an external conduit which is connected to a supply of fluid.

10

There is no need to apply energy to the intraocular irrigation/aspiration device as the lens nucleus has already been fragmented or emulsified during phaco-emulsification. The device is connected to an aspirator which applies suction to the lumen and hence to the opening at the tip. In this way residual lens material is drawn through the opening and  
15 then along the lumen so as to remove the residual lens material from the interior of the eye. Simultaneously, fluid is fed through the external conduit to the interior of the eye to replace the aspirated fluid and maintain the volume of fluid and pressure within the chamber of the eye.

20 In operation of the intraocular irrigation/aspiration device, it is important to ensure that there is a balance between infusion and aspiration of fluids so as to maintain stable pressure and volume within the intraocular chambers. This reduces the likelihood of inadvertent aspiration of structures such as the iris, or the delicate posterior capsule which divides the eye into anterior and posterior chambers. The posterior capsule is liable to  
25 rupture if engaged by the aspiration port which may result in loss of the vitreous gel which fills the posterior chamber of the eye. An intact capsule is also important to support a posterior chamber intraocular lens implant, and therefore inadvertent rupture of the posterior capsule is a serious complication which may result in an unsatisfactory technical result and a poor visual outcome from cataract surgery. It has been found that the distal  
30 opening or port of the tip of the aspiration device sometimes becomes transiently blocked

or occluded during aspiration such as by a relatively large piece of residual lens material. This leads to a temporary increase in vacuum within the lumen which is relieved when the blocking material is eventually drawn through the opening with equalisation of pressure within the chamber of the eye and the aspiration device. However, this equalisation of pressure can induce a surge of fluid along the lumen and a transient reduction in pressure and volume within the pressure of the eye or chamber instability. It is important that adequate infusion of fluid is available to counteract the reduction in pressure and volume.

An outer sleeve of the irrigation/aspiration device may be formed from rigid plastic or metal which resist deformation by the incision. A rigid sleeve however, increases leakage from the wound reducing pressure within the eye, and the ability to maintain a stable chamber volume of fluid. A soft outer sleeve is better able to seal the incision and reduce wound leakage. A tight sealed incision however, may compress a soft sleeve and reduce the flow and infusion of the irrigating fluid into the eye which is necessary to replace aspirated fluid and maintain a stable chamber with respect to pressure and volume.

#### SUMMARY OF THE INVENTION

The present invention provides an intraocular irrigation/aspiration device in which the aspiration of fluid and lens material is regulated and the post occlusion surge phenomenon is reduced.

In accordance with one aspect of the present invention there is provided an intraocular irrigation/aspiration device including a hollow shaft having first and second ends, a tip at the first end of the shaft, said tip including an opening and a lumen extending from the opening to the second end of the shaft, wherein the lumen has a portion of reduced internal cross-sectional area over at least part of its length.

#### BRIEF DESCRIPTION OF THE DRAWINGS

The present invention will now be described, by way of example, with reference to the accompanying drawings, in which:-

4

Figure 1 is perspective view of a first embodiment of intraocular irrigation/aspiration device according to the present invention;

Figure 2 is a view similar to Figure 1 with an outer sleeve shown in phantom;

5

Figure 3 is a longitudinal section through the device of Figures 1 and 2;

Figure 4 is a perspective view of a second embodiment of intraocular irrigation/aspiration device according to the present invention;

10

Figure 5 is a view similar to Figure 4 with an outer sleeve shown in phantom;

Figure 6 is a longitudinal section through the device of Figures 4 and 5;

15 Figure 7 is a perspective view of a third embodiment of intraocular irrigation/aspiration device according to the present invention;

Figure 8 is a view similar to Figure 7 with an outer sleeve shown in phantom;

20 Figure 9 is a longitudinal section through the device of Figures 7 and 8;

Figure 10 is a transverse section along the line 10-10 of Figure 9;

Figure 11 is a side elevation of a modified form of device in accordance with the present  
25 invention including a bent distal portion; and

Figure 12 is a side elevation of a modified form of device in accordance with the present invention including a curved shaft.

30 DETAILED DESCRIPTION OF THE PREFERRED EMBODIMENTS

In Figures 1 to 3, there is shown an intraocular irrigation/aspiration device 10 in accordance with the present invention.

The device 10 includes a shaft 12 having a first or distal end 14 and a second or proximal end 16. The shaft 12 is hollow and includes a lumen 18 extending from the distal end 14 to the proximal end 16. At the distal end 14 there is provided a distal tip portion 20 which includes an opening 22. Adjacent the tip portion 20 there is provided a mid-region portion 24 of reduced external and internal dimension.

10 The shaft 12 is typically formed of metal. Extending around the shaft 12 is an annular external sleeve 26. The sleeve 26 is formed of any suitable material which may be elastomeric material or metal. Elastomeric material is far more flexible than metal and is therefore preferred for most applications. The sleeve 26 and the shaft 12 define an annular external passageway or conduit 28 extending between the first and second ends  
15 14 and 16.

The opening 22 is typically about 0.3mm in lateral dimension. Further, the shaft 12 at the distal tip portion 20 is typically of the order of 0.6 to 1.0mm in internal cross sectional dimension such as about 0.8mm in internal cross sectional dimension. The shaft 12 at the  
20 mid-region portion 24 is of lesser internal dimension than the distal portion and is typically of the order of 0.1 to 0.5mm in internal cross sectional dimension such as about 0.3mm.

Further, the shaft 12 at the tip portion 20 is typically of the order of 0.8 to 1.2mm in external cross sectional dimension such as about 1.00mm in external cross sectional  
25 dimension. The mid-region portion 24 is typically about 0.4 to 0.8mm in external cross sectional dimension such as about 0.6mm. The shaft 12 may have a wall thickness of about 0.1mm.

The sleeve 26 may have an internal cross-sectional dimension of about 1.5 to 3mm such  
30 as about 2mm.

In use, the device 10 is inserted through an incision in an eye such that the distal tip portion 20 is located within the eye and the wall of the eye is in engagement with the outer sleeve 26 at a point corresponding with the proximal portion 24. Fluid is infused into the eye through the annular passageway 28 and simultaneously fluid and residual lens material 5 is aspirated through the opening 22 and the lumen 18. The presence of the mid-region portion 24 of the lumen 18 with reduced internal diameter means that if there is a temporary blockage or occlusion of the opening 22, which is then released suddenly, the surge of fluid along the lumen 18 is constrained by the reduced diameter of the proximal portion compared to the distal portion. This reduces fluctuations in volume and pressure 10 in the intraocular chambers of the eye.

The narrower proximal lumen also increases the resistance to aspirational flow whilst maintaining the size of the aspiration port 22, at approximately 0.3mm. The device therefore favourably regulates aspirational flow.

15

Reducing the size of the aspiration port to less than 0.3mm would increase the resistance to aspiration flow, but would compromise the efficiency of removal of soft lens material as only smaller fragments could be engaged by the aspiration port. Furthermore, simply reducing the size of the aspiration port to less than 0.3mm would not diminish the post 20 occlusion surge phenomena described previously.

Further, as can be seen in Figure 3 especially the device 10 is connected to a handle 30. The handle 30 contains a first conduit 32 which is connected in use to an aspirator (not shown) and a second conduit 34 which is connected in use to a supply of fluid (not 25 shown). The conduit 32 is connected to the lumen 18 and the conduit 34 is connected to the passageway 28. The handle 30 may be formed separately from the device 10 or it may be formed integrally therewith.

Also, the reduced external cross-sectional dimension of the mid-region portion 24, 30 especially in the case where the sleeve 26 is formed of elastomeric or other flexible



material, enables a small incision in the eye to engage closely with the shaft 12. This reduces wound leakage, but also increases the infusion of fluid compared with a conventional intraocular irrigation/aspiration device. The device also enhances the flow of infusion fluid necessary to compensate for fluctuations in chamber pressure and volume  
5 caused by aspiration. The balance between infusion and aspiration is therefore enhanced which increases the stability of the chamber and improves the safety of the cataract procedure. The irrigation/aspiration device therefore helps regulate aspirational flow, and reduces the post occlusion surge phenomena, but also improves the infusion of irrigating fluid available to respond to reductions in chamber volume and pressure.

10

The balance between the outflow of fluid from the eye due to aspiration and wound leakage, and the inflow of fluid due to irrigation, is favourably influenced by the design of the irrigation/aspiration device resulting in a deeper more stable pressurised anterior chamber enhancing the safety of this phase of the cataract procedure.

15

In Figures 4 to 6 there is shown a second embodiment of an intraocular irrigation/aspiration device 40 in accordance with the present invention. The embodiment of Figures 4 to 6 is similar to that of Figures 1 to 3 and like reference numerals denote like parts.

20

Further, in the second embodiment the mid-region portion of lumen 18 is of reduced internal cross-sectional dimension compared to the distal portion as in the first embodiment. However, the external cross-sectional dimension of the proximal portion 42 of the shaft 12 is substantially the same as the external cross-sectional dimension of the  
25 distal portion. Thus, the shaft 12 has substantially the same external cross-sectional dimension throughout as best seen in Figure 6.

In the second embodiment the advantage of reduction of surge of pressure after occlusion and the regulation of aspiration is still obtained as with the first embodiment but the  
30 ability to operate with a small incision in the eye with improved infusion of fluid compared

with conventional devices is not achieved.

In Figures 7 to 10 there is shown a third embodiment of an intraocular irrigation/aspiration device 50 in accordance with the present invention. The embodiment of Figures 7 to 10 5 is similar to that of Figures 1 to 3 and like reference numerals denote like parts.

In the third embodiment shown in Figures 7 to 10 a mid-region portion 52 of the shaft 12 has reduced internal and external cross-sectional dimensions as in Figures 1 to 3. However, the mid-region portion 52 also has a plurality of outwardly extending spaced 10 external projections 54 as best seen in Figure 10. As shown, the projections 54 are preferably in the form of longitudinally extending ribs. The projections 54 ensure that the sleeve 26 even when formed of elastomeric or other flexible material is not pushed firmly into engagement with the shaft 12 by the wall of the eye. This ensures that there is always a clear path for infusion liquid to pass to the interior of the eye along the 15 passageway 28.

Further, as can be seen in Figure 7, the sleeve 26 may have at least one opening 56 adjacent a distal end thereof for escape of irrigating fluid. Preferably, there are two opposed openings 56, one on either side, for this purpose. Openings equivalent to the 20 openings 56 may also be found in the first and second embodiments of the present invention described hereinabove.

In Figure 11, there is shown an intraocular irrigation/aspiration device 60 in accordance with the present invention (with the sleeve 26 absent for greater clarity) in which the distal 25 portion 62 is bent compared to the remainder of the shaft 12, that is, the distal portion 62 is inclined at an angle to the remainder of the shaft 12. In the embodiments of Figures 1 to 10 the distal portion 20 is aligned with the remainder of the shaft 12.

In Figure 12 there is shown an intraocular irrigation/aspiration device 70 in accordance 30 with the present invention which includes a curved shaft 72 whereas in the embodiments

of Figures 1 to 10 the shaft 12 is straight.

The various components such as the shaft 12 and the annular sleeve 26 in the device of the present invention are preferably circular in shape in which case the cross-sectional 5 dimensions referred to hereabove may be referred to as cross-sectional diameters.

However, it is to be understood that the various components of the device of the present invention may have other cross-sectional shapes.

Modifications and variations such as would be apparent to a skilled addressee are deemed 10 within the scope of the present invention.

CLAIMS

1. An intraocular irrigation/aspiration device including a hollow shaft having distal and proximal ends, a tip at the distal end of the shaft, said tip including an opening and a lumen extending from the opening to the proximal end of the shaft, wherein the lumen has  
5 a portion of reduced internal cross-sectional area over at least part of its length.
2. An intraocular irrigation/aspiration device according to claim 1, characterised in that the hollow shaft includes a distal tip portion having the opening and a mid-region portion, the distal tip portion having a first internal cross-sectional area and the mid-  
10 region portion having a second internal cross-sectional area which is less than the first internal cross-sectional area.
3. An intraocular irrigation/aspiration device according to claim 2, characterised in that the distal tip portion has an internal cross-sectional dimension in the range from about  
15 0.6 to 1.00 mm.
4. An intraocular irrigation/aspiration device according to claim 2 or 3, characterised in that the mid-region portion has an internal cross-sectional dimension in the range from about 0.1 to 0.5mm.  
20
5. An intraocular irrigation/aspiration device according to any one of claims 2 to 4, characterised in that the mid-region portion has an external dimension smaller than the external dimension of the distal tip portion.
- 25 6. An intraocular irrigation/aspiration device according to Claim 5, characterised in that the distal tip portion has a cross-sectional dimension in the range from about 0.8 to 1.2mm.
7. An intraocular irrigation/aspiration device according to claim 5 or 6, characterised  
30 in that the mid-region portion has an external cross-sectional dimension in the range from

about 0.4 to 0.8mm.

8. An intraocular irrigation/aspiration device according to any one of claims 2 to 4, characterised in that the mid-region portion is of substantially the same cross-sectional  
5 dimension as the distal tip portion.

9. An intraocular irrigation/aspiration device according to claim 8, characterised in that the distal tip portion and the mid-region portion have external cross-sectional dimensions in the range from about 0.8 to 1.2mm.

10

10. An intraocular irrigation/aspiration device according to any one of claims 2 to 4, characterised in that the mid-region portion has an external dimension smaller than the external dimension of the distal tip portion, and the mid-region portion has plurality of outwardly extending spaced external projections so as to ensure that there is a clear path  
15 for infusion liquid.

11. An intraocular irrigation/aspiration device according to claim 10, characterised in that the projections are in the form of longitudinally extending ribs.

20 12. An intraocular irrigation/aspiration device according to any one of the preceding claims, characterised in that an annular external sleeve extends around the shaft.

13. An intraocular irrigation/aspiration device according to claim 12, characterised in that the sleeve is flexible.

25

14. An intraocular irrigation/aspiration device according to claim 13, characterised in that the sleeve is formed of elastomeric material.

15. An intraocular irrigation/aspiration device according to any one of claims 12 to 14,  
30 characterised in that the sleeve has at least one opening adjacent a distal end thereof for

escape of irrigating fluid.

16. An intraocular irrigation/aspiration device according to any one of claims 12 to 15, characterised in that the sleeve has an internal cross-sectional dimension in the range 5 from about 1.5 to 3.0mm.

17. An intraocular irrigation/aspiration device according to any one of claims 12 to 16, characterised in that the sleeve together with the shaft defines an annular external passageway extending between the first and second ends of the shaft.

10

18. An intraocular irrigation/aspiration device according to claim 17, characterised in that the device is connected to a handle containing a first conduit arranged to be connected to an aspirator and a second conduit arranged to be connected to a supply of fluid, the first conduit being connected to the lumen and the second conduit being 15 connected to the annular external passageway.

19. An intraocular irrigation/aspiration device according to any of the preceding claims, characterised in that the shaft is straight throughout.

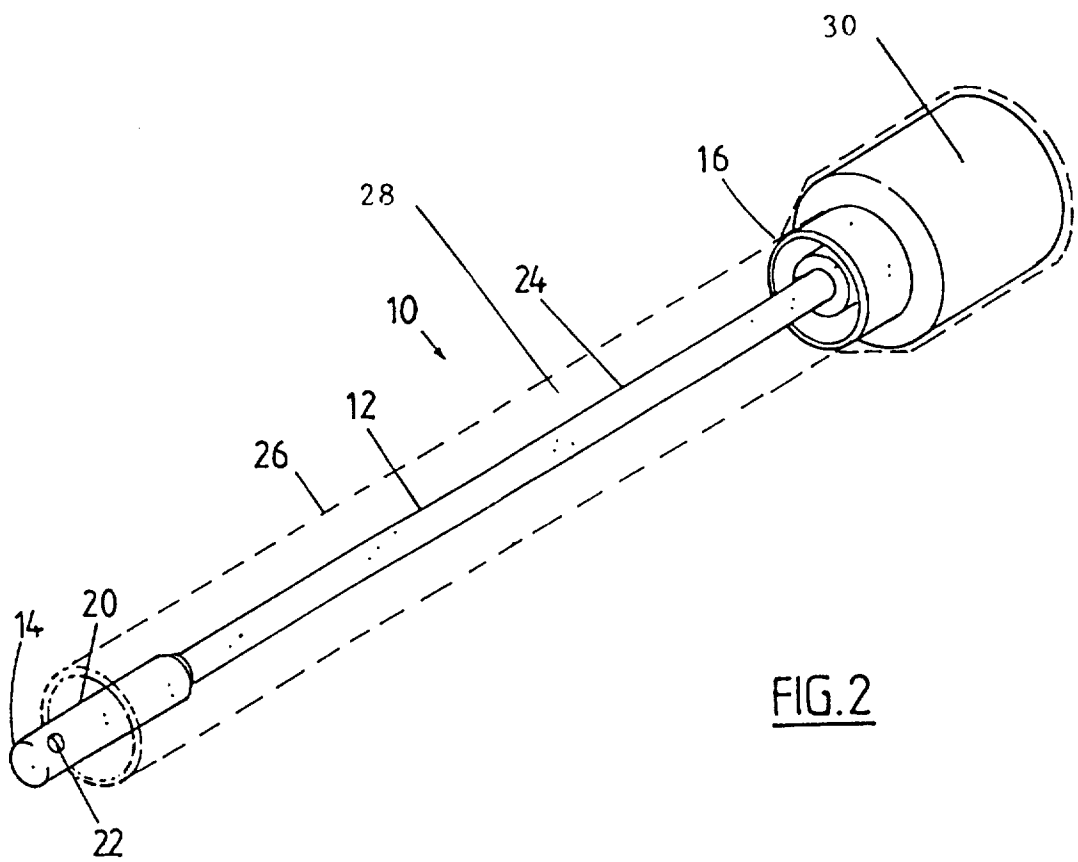
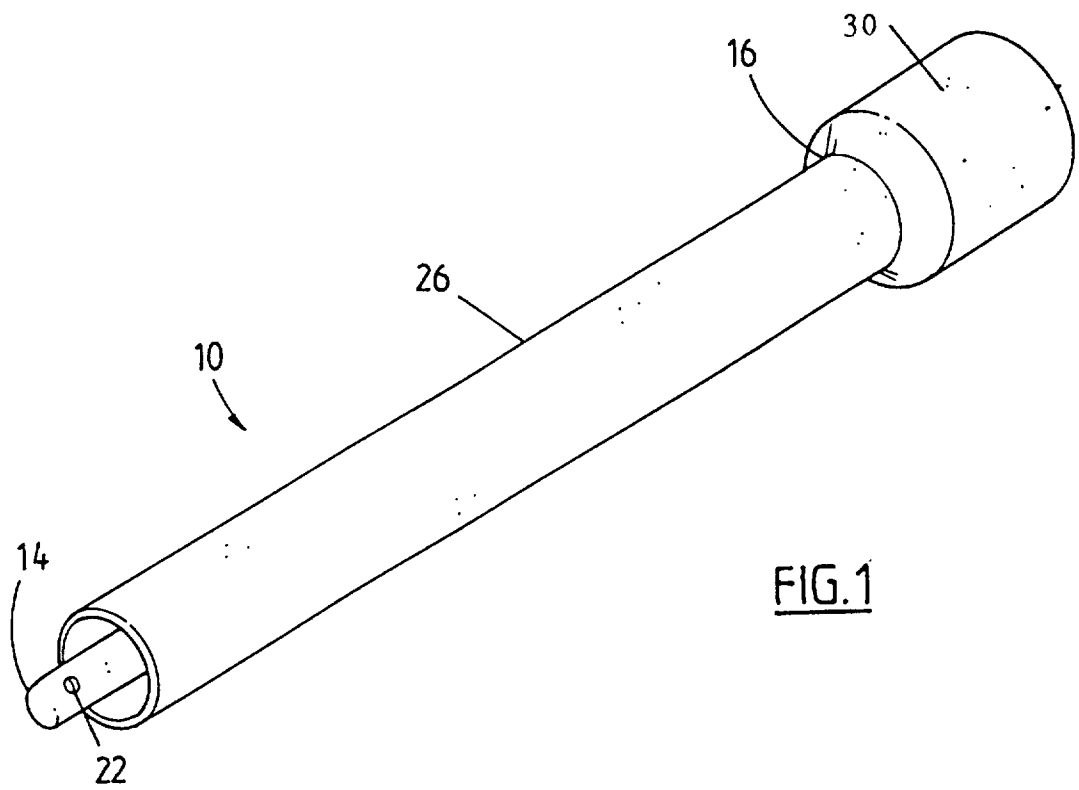

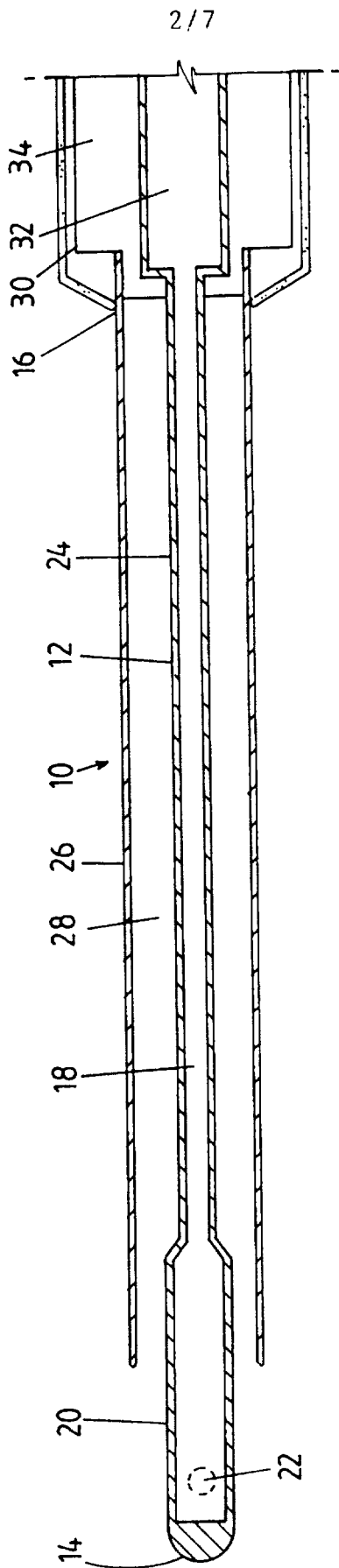
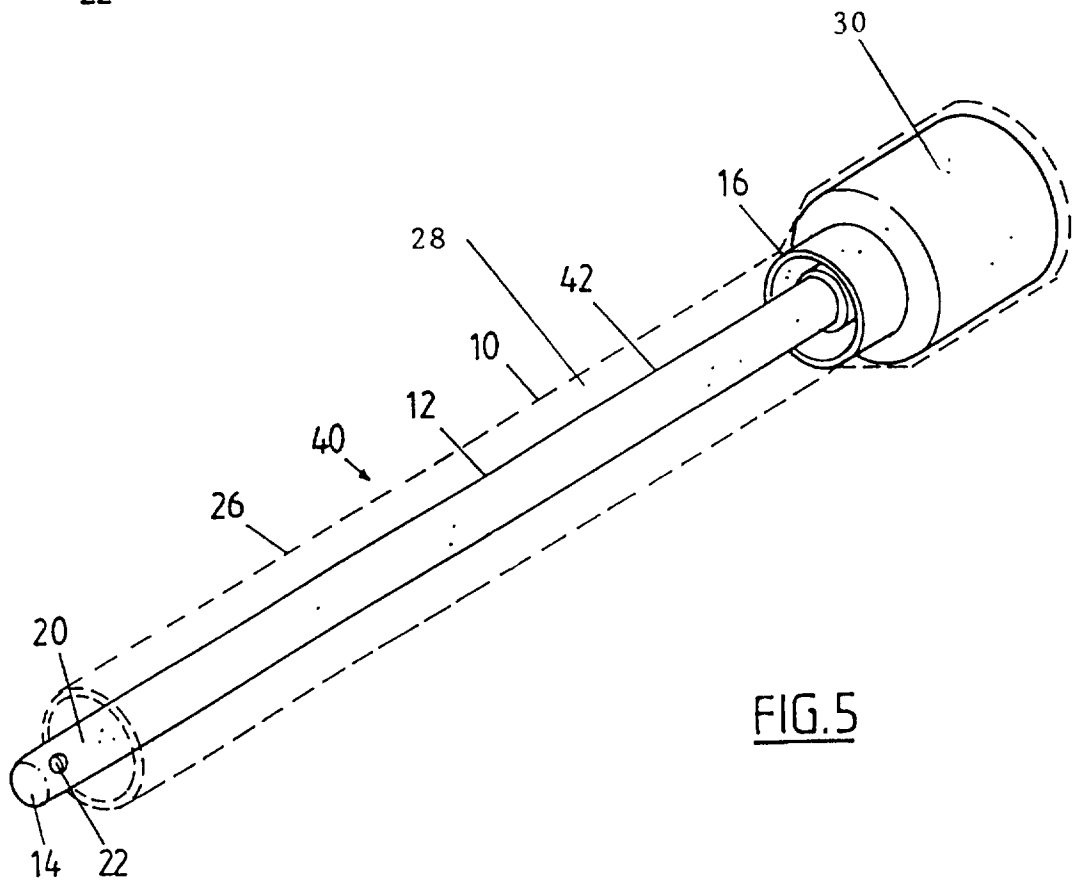
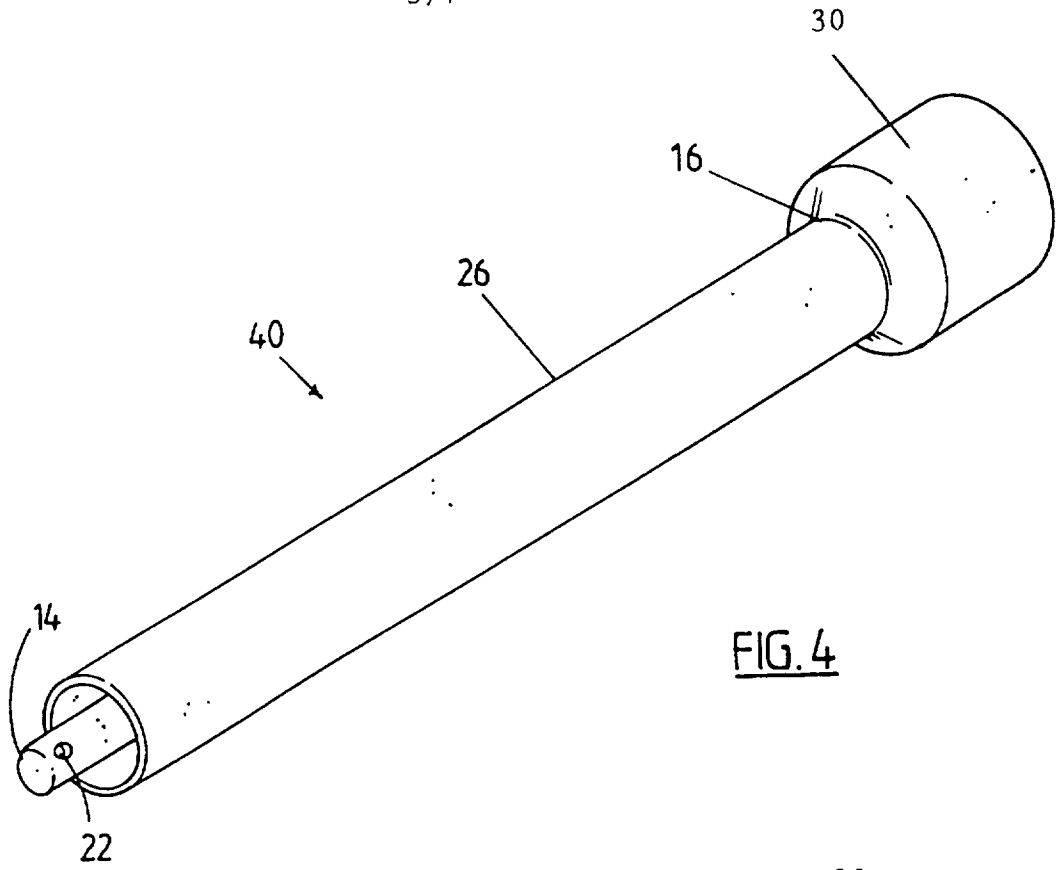

FIG. 3





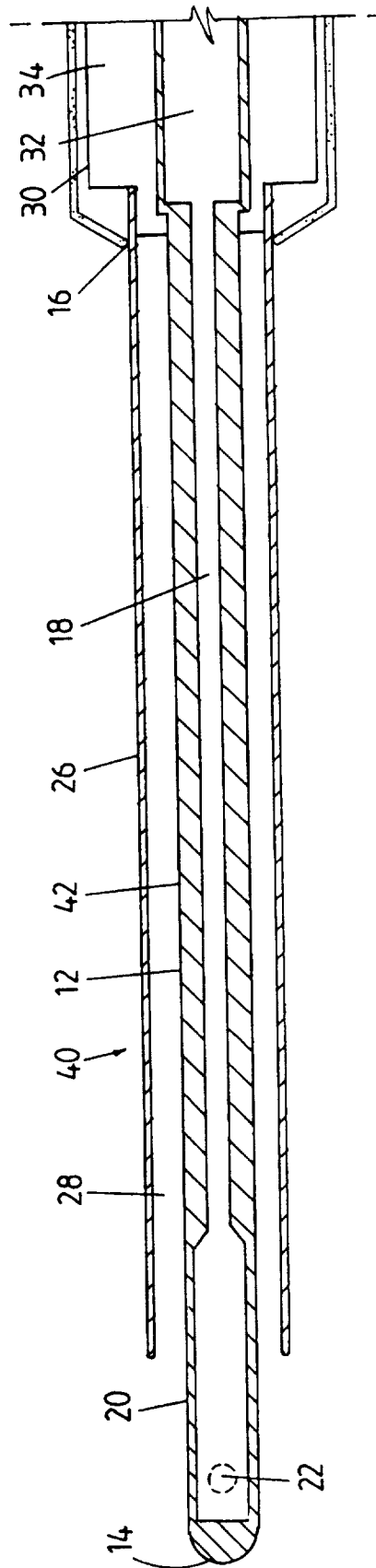
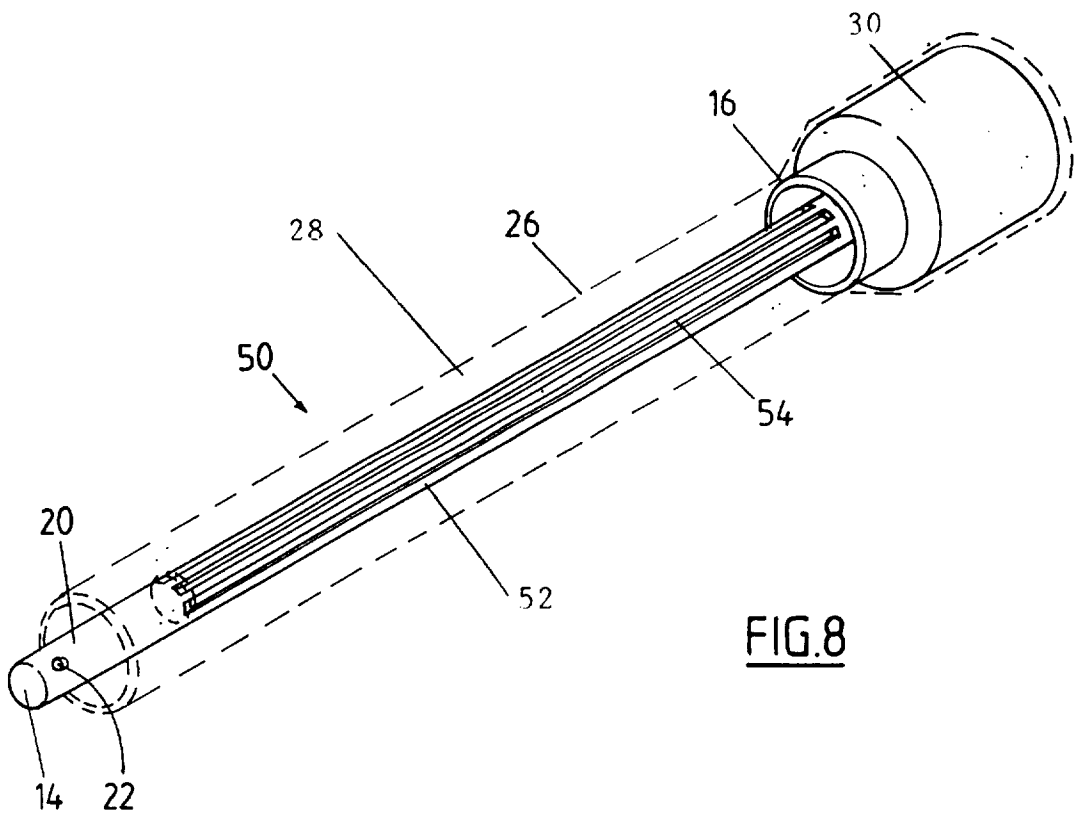
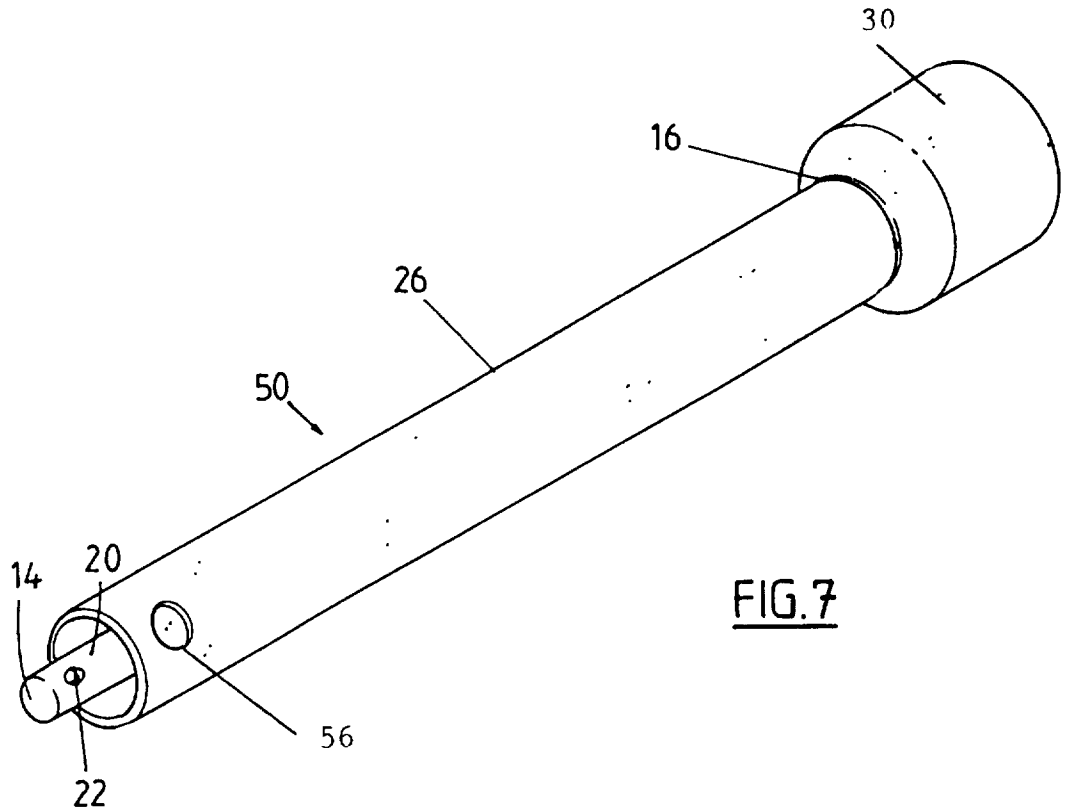

FIG. 6



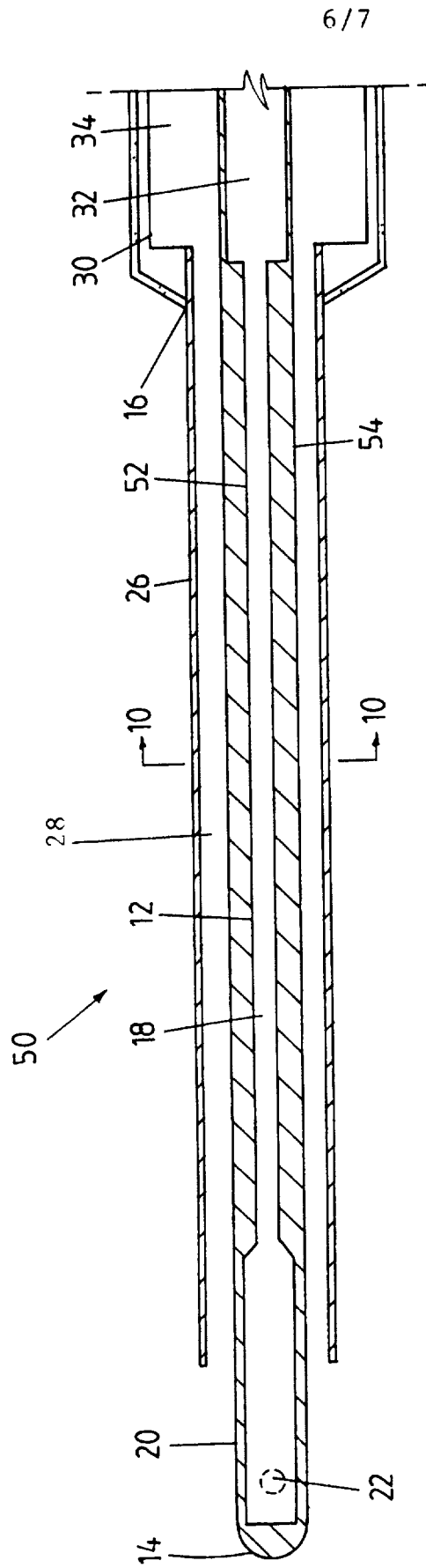

FIG. 9

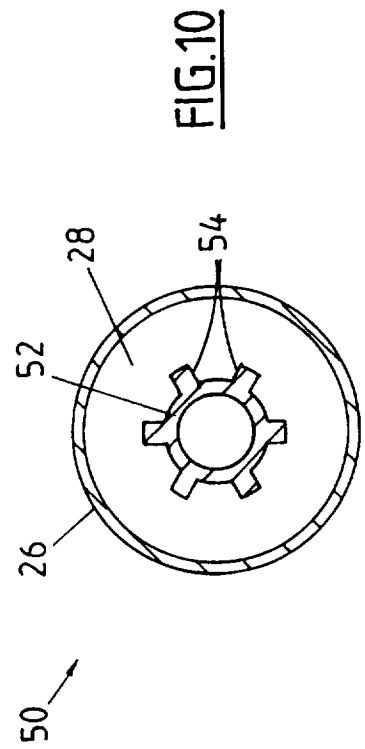

FIG. 10

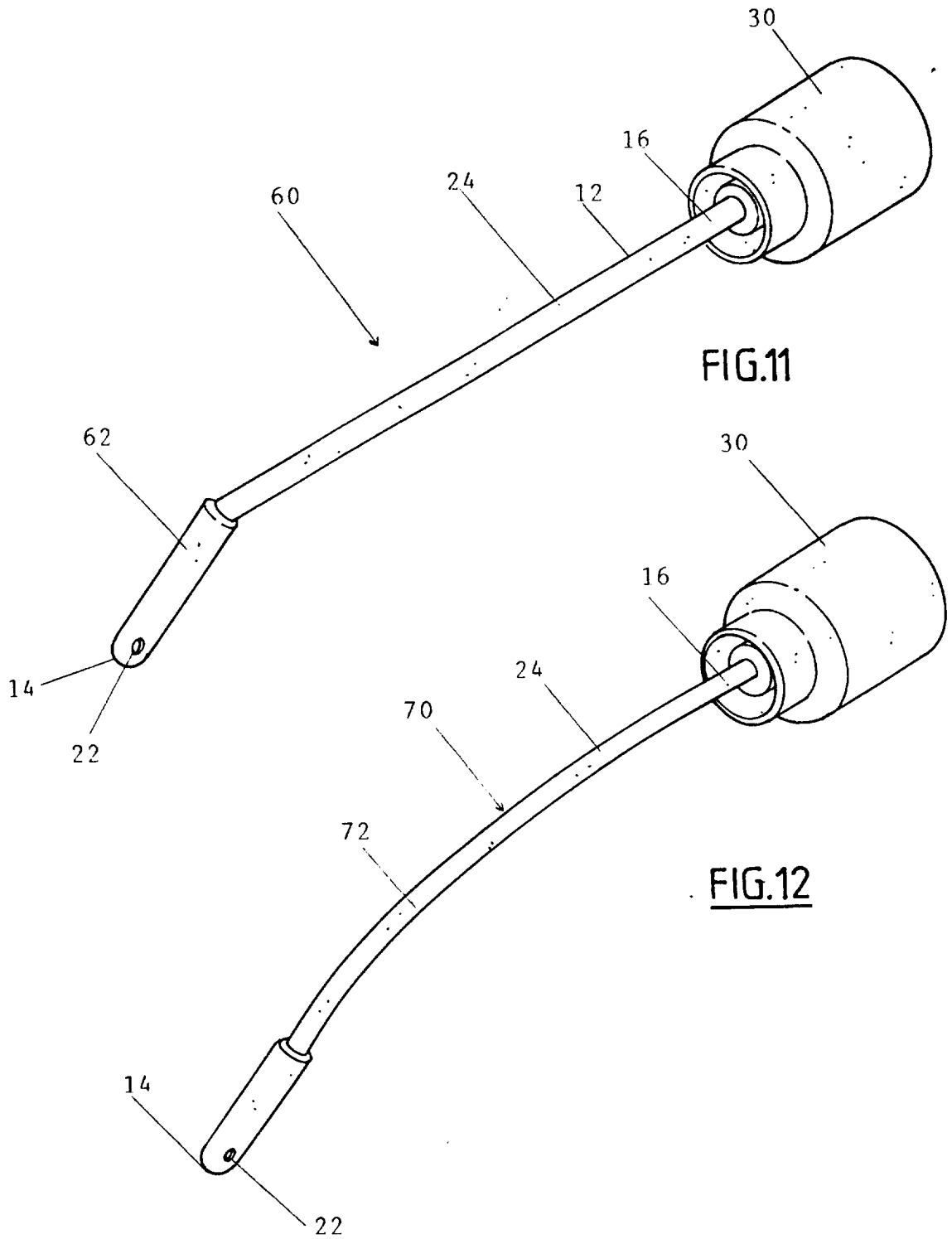

FIG.11

FIG.12

# INTERNATIONAL SEARCH REPORT

International Application No.  
PCT/AU 97/00536

<b>A. CLASSIFICATION OF SUBJECT MATTER</b>		
Int Cl <sup>6</sup> : A61F 9/007		
According to International Patent Classification (IPC) or to both national classification and IPC		
<b>B. FIELDS SEARCHED</b>		
Minimum documentation searched (classification system followed by classification symbols) IPC 6: A61		
Documentation searched other than minimum documentation to the extent that such documents are included in the fields searched AU: A61F 9/IC		
Electronic data base consulted during the international search (name of data base and, where practicable, search terms used) WPAT: PHACOEMULSIF: OR PHACO ( ) EMULS: JAPIO: SAME AS WPAT		
<b>C. DOCUMENTS CONSIDERED TO BE RELEVANT</b>		
Category*	Citation of document, with indication, where appropriate, of the relevant passages	Relevant to claim No.
P, X	AU 62683/96 A (SURGICAL DESIGN CORPORATION) 5 December 1996 Figs 7A, 28-30	1-9, 12-18
X	AU 33365/95 A (OVERSBY PTY. LTD.) 14 March 1996 entire document	1-19
X	Patent Abstracts of Japan, JP, 8-038541 A (NIDEK CO. LTD.) 13 February 1996 entire abstract	1-4, 19
<input checked="" type="checkbox"/> Further documents are listed in the continuation of Box C <input checked="" type="checkbox"/> See patent family annex		
<p>* Special categories of cited documents:</p> <p>"A" document defining the general state of the art which is not considered to be of particular relevance</p> <p>"E" earlier document but published on or after the international filing date</p> <p>"L" document which may throw doubts on priority claim(s) or which is cited to establish the publication date of another citation or other special reason (as specified)</p> <p>"O" document referring to an oral disclosure, use, exhibition or other means</p> <p>"P" document published prior to the international filing date but later than the priority date claimed</p> <p>"T" later document published after the international filing date or priority date and not in conflict with the application but cited to understand the principle or theory underlying the invention</p> <p>"X" document of particular relevance; the claimed invention cannot be considered novel or cannot be considered to involve an inventive step when the document is taken alone</p> <p>"Y" document of particular relevance; the claimed invention cannot be considered to involve an inventive step when the document is combined with one or more other such documents, such combination being obvious to a person skilled in the art</p> <p>"&amp;" document member of the same patent family</p>		
Date of the actual completion of the international search 22 September 1997		Date of mailing of the international search report <b>29 SEP 1997</b>
Name and mailing address of the ISA/AU AUSTRALIAN INDUSTRIAL PROPERTY ORGANISATION PO BOX 200 WODEN ACT 2606 AUSTRALIA Facsimile No.: (02) 6285 3929		Authorized officer <b>SUE THOMAS</b> Telephone No.: (02) 6283 2454

# INTERNATIONAL SEARCH REPORT

International Application No.

PCT/AU 97/00536

C (Continuation) DOCUMENTS CONSIDERED TO BE RELEVANT		
Category*	Citation of document, with indication, where appropriate, of the relevant passages	Relevant to claim No.
X	WO 94/22402 A1 (DAVIS) 13 October 1994 Figs 3 and 5	1, 2, 8, 9, 19

# INTERNATIONAL SEARCH REPORT

## Information on patent family members

International Application No.  
**PCT/AU 97/00536**

This Annex lists the known "A" publication level patent family members relating to the patent documents cited in the above-mentioned international search report. The Australian Patent Office is in no way liable for these particulars which are merely given for the purpose of information.

Patent Document Cited in Search Report		Patent Family Member					
AU	62683/96	WO	9638091	EP	778750		
AU	33365/95	CA	2198259	EP	778757	WO	9607377
		ZA	9507375				
JP	8038541						
WO	9422402	AU	40557/93				
END OF ANNEX							