

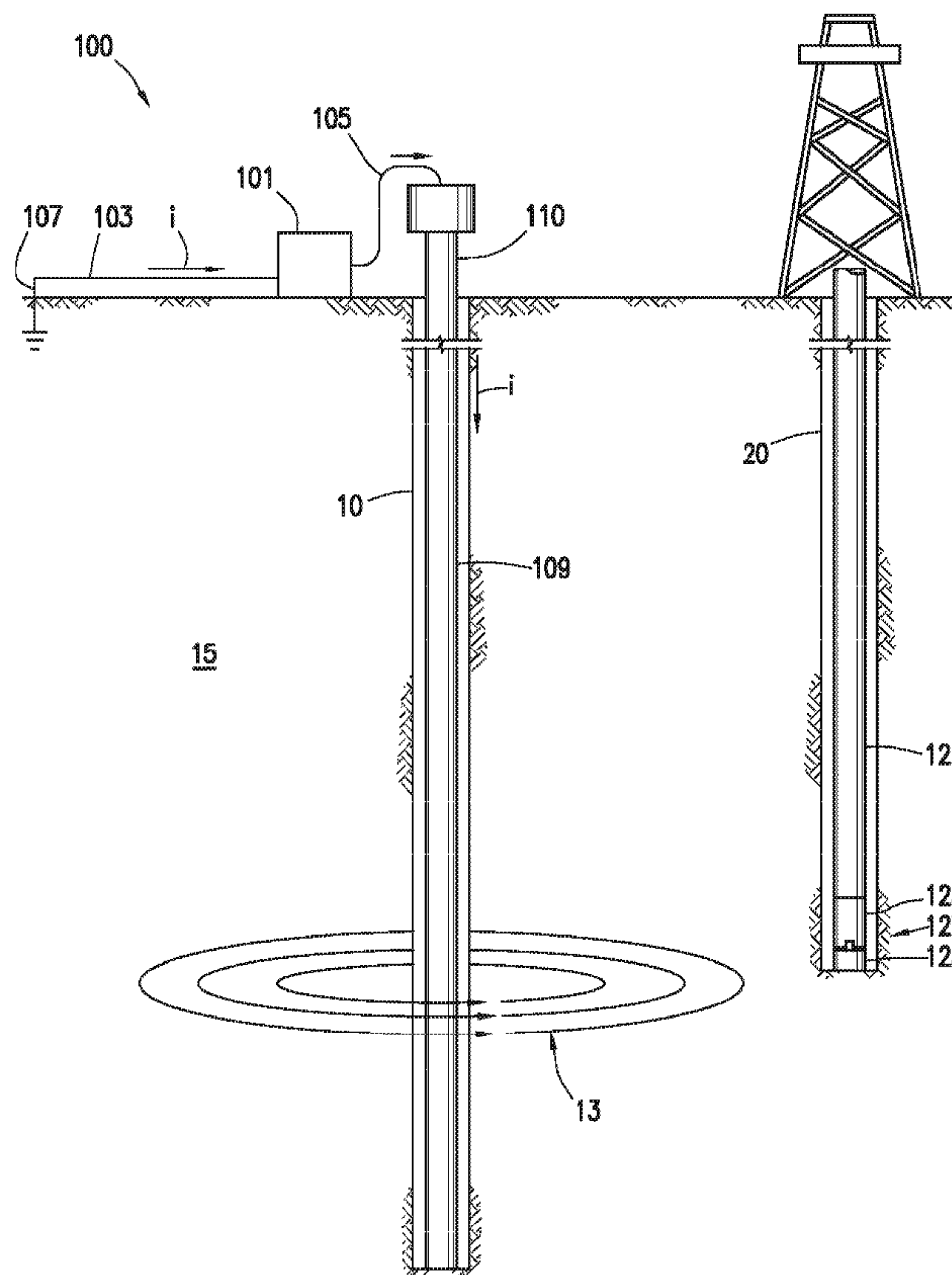

(86) **Date de dépôt PCT/PCT Filing Date:** 2015/10/15
 (87) **Date publication PCT/PCT Publication Date:** 2016/04/21
 (45) **Date de délivrance/Issue Date:** 2018/11/27
 (85) **Entrée phase nationale/National Entry:** 2017/03/01
 (86) **N° demande PCT/PCT Application No.:** US 2015/055778
 (87) **N° publication PCT/PCT Publication No.:** 2016/061376
 (30) **Priorité/Priority:** 2014/10/17 (US62/065,363)

(51) **Cl.Int./Int.Cl. E21B 47/024** (2006.01),
E21B 47/0228 (2012.01), **E21B 7/04** (2006.01)
 (72) **Inventeurs/Inventors:**
MOSS, CLINTON, US;
RIDGWAY, DOUGLAS, US;
MARTIN, TROY, US;
LAPORTA, ARTHUR, US
 (73) **Propriétaire/Owner:**
APPLIED TECHNOLOGIES ASSOCIATES, INC., US
 (74) **Agent:** SMART & BIGGAR

(54) **Titre : FACE DE COUPE AZIMUTALE MAGNETIQUE ACTIVE POUR DEVIATION DE TROU DE FORAGE VERTICAL DANS DES ENVIRONNEMENTS PERTURBES MAGNETIQUEMENT**
 (54) **Title: ACTIVE MAGNETIC AZIMUTHAL TOOLFACE FOR VERTICAL BOREHOLE KICKOFF IN MAGNETICALLY PERTURBED ENVIRONNEMENTS**



(57) **Abrégé/Abstract:**

An artificial toolface reference system includes a power supply providing current to a ground lead and a reference lead. A ground point is coupled to the ground lead and in electrical connection with the ground. A reference wellbore includes a reference

(57) Abrégé(suite)/Abstract(continued):

conductor in electrical connection with the ground. The reference conductor is in electrical connection with the reference lead. A guidance sensor positioned outside the reference wellbore includes at least one magnetometer. The power supply may be used to provide a current through the reference conductor, the ground, and the ground point such that a reference magnetic field is generated along the reference conductor. The guidance sensor may measure the reference magnetic field with a magnetometer. An artificial magnetic toolface may be calculated therefrom.

(12) INTERNATIONAL APPLICATION PUBLISHED UNDER THE PATENT COOPERATION TREATY (PCT)

(19) World Intellectual Property
Organization
International Bureau(10) International Publication Number
WO 2016/061376 A1(43) International Publication Date
21 April 2016 (21.04.2016)(51) International Patent Classification:
E21B 3/06 (2006.01)

Applied Technologies Associates, Inc., 3025 Buena Vista Drive, Paso Robles, CA 93446 (US).

(21) International Application Number:
PCT/US2015/055778(74) Agent: **LOCKLAR, Michael**; Adolph Locklar, 4615 SW Freeway, Suite 630, Houston, TX 77027 (US).(22) International Filing Date:
15 October 2015 (15.10.2015)

(81) Designated States (unless otherwise indicated, for every kind of national protection available): AE, AG, AL, AM, AO, AT, AU, AZ, BA, BB, BG, BH, BN, BR, BW, BY, BZ, CA, CH, CL, CN, CO, CR, CU, CZ, DE, DK, DM, DO, DZ, EC, EE, EG, ES, FI, GB, GD, GE, GH, GM, GT, HN, HR, HU, ID, IL, IN, IR, IS, JP, KE, KG, KN, KP, KR, KZ, LA, LC, LK, LR, LS, LU, LY, MA, MD, ME, MG, MK, MN, MW, MX, MY, MZ, NA, NG, NI, NO, NZ, OM, PA, PE, PG, PH, PL, PT, QA, RO, RS, RU, RW, SA, SC, SD, SE, SG, SK, SL, SM, ST, SV, SY, TH, TJ, TM, TN, TR, TT, TZ, UA, UG, US, UZ, VC, VN, ZA, ZM, ZW.

(25) Filing Language: English

(26) Publication Language: English

(30) Priority Data:
62/065,363 17 October 2014 (17.10.2014) US(71) Applicant: **APPLIED TECHNOLOGIES ASSOCIATES, INC.** [US/US]; 3025 Buena Vista Drive, Paso Robles, CA 93446 (US).(72) Inventors: **MOSS, Clinton**; c/o Applied Technologies Associates, Inc., 3025 Buena Vista Drive, Paso Robles, CA 93446 (US). **RIDGWAY, Douglas**; c/o Applied Technologies Associates, Inc., 3025 Buena Vista Drive, Paso Robles, CA 93446 (US). **MARTIN, Troy**; c/o Applied Technologies Associates, Inc., 3025 Buena Vista Drive, Paso Robles, CA 93446 (US). **LAPORTA, Arthur**; c/o

(84) Designated States (unless otherwise indicated, for every kind of regional protection available): ARIPO (BW, GH, GM, KE, LR, LS, MW, MZ, NA, RW, SD, SL, ST, SZ, TZ, UG, ZM, ZW), Eurasian (AM, AZ, BY, KG, KZ, RU, TJ, TM), European (AL, AT, BE, BG, CH, CY, CZ, DE, DK, EE, ES, FI, FR, GB, GR, HR, HU, IE, IS, IT, LT, LU, LV, MC, MK, MT, NL, NO, PL, PT, RO, RS, SE, SI, SK,

[Continued on next page]

(54) Title: ACTIVE MAGNETIC AZIMUTHAL TOOLFACE FOR VERTICAL BOREHOLE KICKOFF IN MAGNETICALLY PERTURBED ENVIRONMENTS

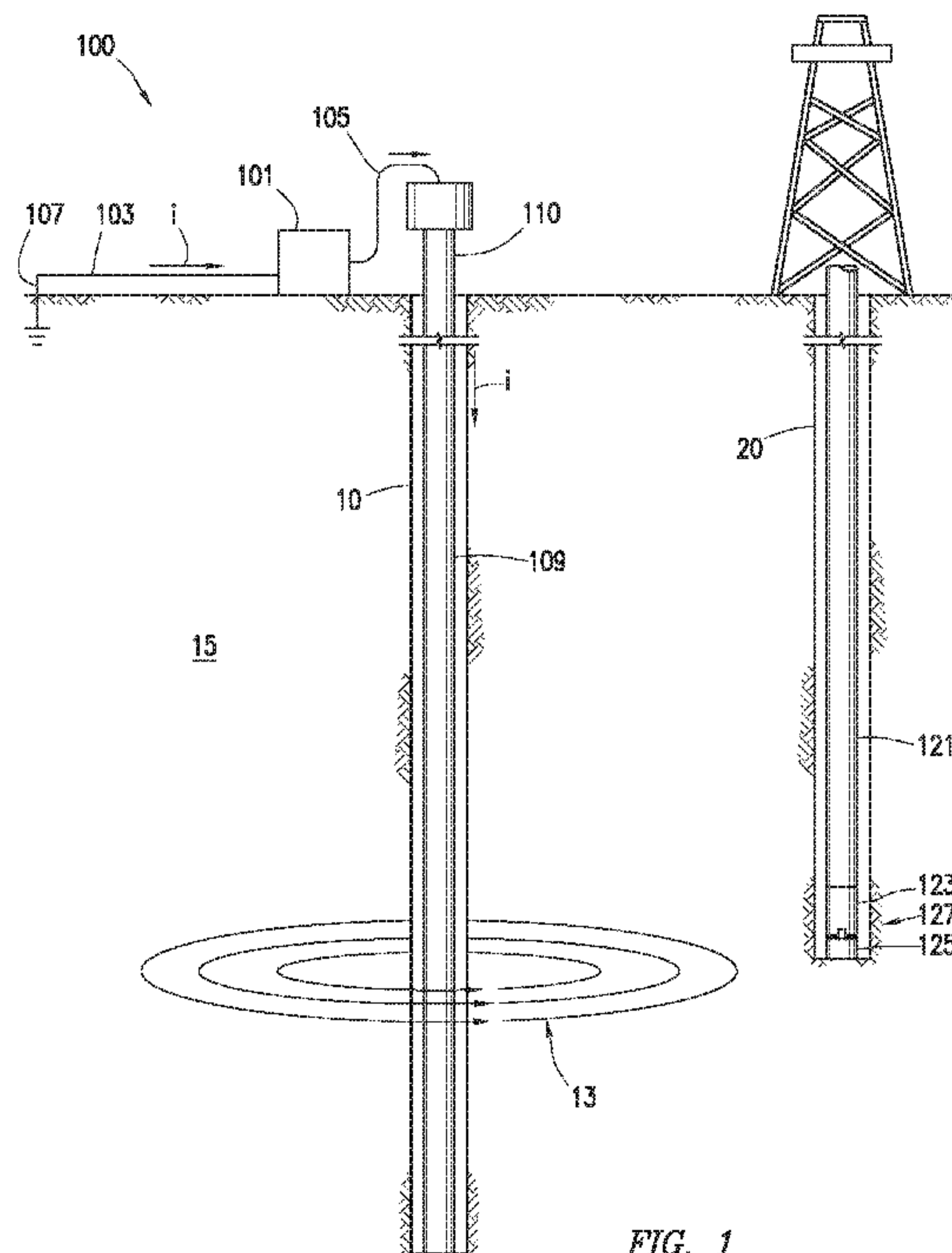

FIG. 1

(57) Abstract: An artificial toolface reference system includes a power supply providing current to a ground lead and a reference lead. A ground point is coupled to the ground lead and in electrical connection with the ground. A reference wellbore includes a reference conductor in electrical connection with the ground. The reference conductor is in electrical connection with the reference lead. A guidance sensor positioned outside the reference wellbore includes at least one magnetometer. The power supply may be used to provide a current through the reference conductor, the ground, and the ground point such that a reference magnetic field is generated along the reference conductor. The guidance sensor may measure the reference magnetic field with a magnetometer. An artificial magnetic toolface may be calculated therefrom.

WO 2016/061376 A1 

SM, TR), OAPI (BF, BJ, CF, CG, CI, CM, GA, GN, GQ, GW, KM, ML, MR, NE, SN, TD, TG). **Published:**

— *with international search report (Art. 21(3))*

**ACTIVE MAGNETIC AZIMUTHAL TOOLFACE FOR VERTICAL
BOREHOLE KICKOFF IN MAGNETICALLY PERTURBED
ENVIRONMENTS**

Cross-Reference to Related Applications

5 [0001] This application claims priority from U.S. provisional application number 62/065,363,
filed October 17, 2014.

Technical Field/Field of the Disclosure

[0002] The present disclosure relates generally to borehole location systems, and specifically
to use of magnetic fields for determination of position of a subsurface wellbore.

10 **Background of the Disclosure**

[0003] Knowledge of wellbore placement and surveying is useful for the development of
subsurface oil & gas deposits. Directional borehole drilling typically relies on one or more
directional devices such as bent subs and rotary steering systems to direct the course of the
wellbore. The angle between the reference direction of the directional device and an external
15 reference direction is referred to as the toolface angle, and determines the direction of
deviation of the wellbore. Directional drilling proceeds through comparing the placement of
the borehole with the desired path, and selecting a toolface angle and other drilling parameters
to advance the borehole and correct it towards the planned path. Measurement of toolface thus
may be a component for borehole steering and placement.

20 [0004] When determining toolface, an external reference direction for the toolface may be
chosen based on the geometry and location of the wellbore. In deviated wellbores, with an
inclination away from vertical in excess of 5-8°, the usual reference is the direction of

acceleration due to gravity. This may be measurable via accelerometers which rotate with the drill string, such as during measurement while drilling (MWD). In a vertical well or near-vertical well, the direction of gravity may be aligned or substantially aligned with the drill string axis and may not be able to provide a useful reference direction. Several alternatives may be used in place of accelerometers in vertical or near-vertical wells. Traditionally, magnetic toolface may be used, which applies the onboard magnetometers used in MWD to use the Earth's magnetic field as a reference direction. However, magnetic toolface may fail at sufficiently high magnetic latitude, or where magnetic interference from nearby wellbores, surface facilities, or other effects alter the local magnetic field. Another alternative for a reference is the true North available from a north-seeking downhole gyroscope, or a reference carried down by a non-north-seeking gyroscope. Gyroscopes may suffer from cost and reliability concerns.

Summary

[0005] The present disclosure provides for an artificial toolface reference system. The artificial toolface reference system may include a power supply providing current to a ground lead and a reference lead. The artificial toolface reference system may further include a ground point, the ground point coupled to the ground lead and in electrical connection with the ground. The artificial toolface reference system may further include a reference wellbore, the reference wellbore including a reference conductor in electrical connection with the ground, the reference conductor in electrical connection with the reference lead. The artificial toolface reference system may further include a guidance sensor positioned outside the reference wellbore including at least one magnetometer.

[0006] The present disclosure also provides for a method. The method may include coupling a power supply between a ground point and a reference conductor. The ground point may be

positioned a distance away from the reference conductor and in electrical communication with the ground. The reference conductor may be positioned in a reference wellbore and in electrical communication with the ground. The method may further include providing a current, with the power supply, through the reference conductor, the ground, and the ground point such that a reference magnetic field is generated along the reference conductor. The method may further include measuring the reference magnetic field with a magnetometer positioned outside of the reference wellbore.

[0006a] The present disclosure also provides for an artificial toolface reference system comprising: a power supply, the power supply providing current to a first ground lead, a second ground lead, and a reference lead; a first ground point, the first ground point coupled to the first ground lead and in electrical connection with the ground; a second ground point, the second ground point coupled to the second ground lead and in electrical connection with the ground; a reference wellbore, the reference wellbore including a reference conductor in electrical connection with the ground, the reference conductor in electrical connection with the reference lead; and a guidance sensor positioned outside the reference wellbore including at least one magnetometer.

[0006b] The present disclosure also provides for a method comprising: coupling a power supply between a first and second ground point and a reference conductor, the first and second ground points positioned a distance away from the reference conductor and in electrical communication with the ground, the reference conductor positioned in a reference wellbore and in electrical communication with the ground, the first and second ground points positioned in opposite directions relative to the reference wellbore; providing a current, with the power

supply, through the reference conductor, the ground, and the first and second ground points such that a reference magnetic field is generated along the reference conductor; and measuring the reference magnetic field with a magnetometer positioned outside of the reference wellbore.

Brief Description of the Drawings

5 [0007] The present disclosure is best understood from the following detailed description when read with the accompanying figures. It is emphasized that, in accordance with the standard practice in the industry, various features are not drawn to scale. In fact, the dimensions of the various features may be arbitrarily increased or reduced for clarity of discussion.

[0008] FIG. 1 depicts an artificial toolface reference system consistent with at least one
10 embodiment of the present disclosure.

[0009] FIG. 2 depicts an artificial toolface reference system consistent with at least one embodiment of the present disclosure.

[0010] FIG. 3 depicts a schematic view of the artificial toolface reference system of FIG. 2.

Detailed Description

15 [0011] It is to be understood that the following disclosure provides many different embodiments, or examples, for implementing different features of various embodiments. Specific examples of components and arrangements are described below to simplify the present disclosure. These are,

of course, merely examples and are not intended to be limiting. In addition, the present disclosure may repeat reference numerals and/or letters in the various examples. This repetition is for the purpose of simplicity and clarity and does not in itself dictate a relationship between the various embodiments and/or configurations discussed.

[0012] FIG. 1 depicts an embodiment of artificial toolface reference system 100. Artificial toolface reference system 100 may include power supply 101. Power supply 101 may be any device capable of providing a current as described herein, and may constitute a current supply or voltage supply as understood in the art. Power supply 101 may be in electrical connection between ground lead 103 and reference lead 105. Ground lead 103 may be in electrical connection to grounding point 107. Reference lead 105 may be in electrical connection to reference conductor 109 positioned in reference wellbore 10. Reference conductor 109 may be any conductor positioned within reference wellbore 10. Reference conductor 109 may be any conductor or combination of conductors axially aligned with reference wellbore 10. For example and without limitation, reference conductor 109 may be a length or string of tubing or casing. In some embodiments, reference conductor 109 may be a drill stem or other length of drill string positioned in the wellbore, including a fish or other downhole tool. In some embodiments, reference lead 105 may electrically couple to reference conductor 109 at an upper end 110 of reference conductor 109 at or near the surface of the ground 15. In some embodiments, reference conductor 109 may be a wire or cable positioned in reference wellbore 10 for communication with or providing power to a piece of downhole equipment. For example, in some embodiments, reference conductor 109 may be a wire for a downhole pump (not shown) positioned in reference wellbore 10. As understood in the art, one or more additional wires may be included in the wire for the downhole pump, which may be used as described herein. Although reference lead 105 is

depicted as coupling to reference conductor 109 at the surface of ground 15, in some embodiments, reference lead 105 may be positioned within reference conductor 109 to make electrical contact with reference conductor 109 along its length within reference wellbore 10. For example, in some embodiments, a single wire (not shown) may be extended through reference conductor 109 and may make electrical contact therewith at a point on reference conductor 109 away from the surface of ground 15. In some embodiments, the wire may contact reference conductor 109 by gravity at, for example and without limitation, a deviation in the direction of reference conductor 109. In some embodiments, the wire may be coupled to a centralizer or other device having one or more conductive extensions such as bow springs to contact reference conductor 109. In some embodiments, the wire may be electrically coupled to reference conductor 109 through a conductive fluid within reference conductor 109.

[0013] Grounding point 107 may be in electrical connection with the surrounding ground 15. Grounding point 107 may include, for example and without limitation, one or more grounding stakes driven into ground 15. In some embodiments, grounding point 107 may be an existing casing or well. In some embodiments, grounding point 107 may be positioned at a distance from reference wellbore 10. In some embodiments, grounding point 107 may be any other electrical ground including, without limitation, culverts, gates, or other structures.

[0014] In some embodiments, reference conductor 109 may be electrically conductive, such that current i travels from power supply 101 through reference lead 105 into reference conductor 109. Because reference conductor 109 is conductive, current flows through reference conductor 109. Current i may then travel through ground 15 to grounding point 107 to return to power supply 101 through ground lead 103. In some embodiments, grounding point 107 may be positioned a

sufficient distance from reference wellbore 10 such that current i leaves reference conductor 109, without being bound by theory, in a substantially isotropic manner according to Ampere's law.

[0015] As current i flows through reference conductor 109, reference magnetic field B is generated thereby, without being bound by theory, according to Faraday's law. Reference magnetic field B extends along the length of reference conductor 109 and is in a plane orthogonal to the flow of current i . Because current i extends substantially isotropically from reference conductor 109 into ground 15, the current between reference conductor 109 and grounding point 107 may not produce a magnetic field as understood in the art.

[0016] FIG. 1 also depicts guided wellbore 20. Guided wellbore 20 may include guided drilling string 121. Guided drilling string 121 may include guidance sensor 123. Guided drilling string 121 may also include one or more downhole tools for forming guided wellbore 20, including, for example and without limitation, drill bit 125, BHA 127. In some embodiments, guidance sensor 123 may be included in BHA 127 as shown in FIG. 1. In some embodiments, guidance sensor 123 may be included as part of a MWD system. In some embodiments, guided drilling string 121 may include one or more downhole tools having reference directions, including, for example and without limitation, a rotary steerable system, bent sub, or other tool. In certain embodiments, the radial orientation of the reference direction within guided wellbore 20 is determined. The orientation of the reference direction of the downhole tool may be referred to as the toolface of guided drilling string 121. For example, if a bent sub is included as part of guided drilling string 121, the direction of the bend may correspond with the reference direction, and the angle between the reference direction and a magnetic field defining the toolface of guided drilling string 121.

[0017] In some embodiments, guidance sensor 123 may include one or more magnetometers adapted to detect reference magnetic field B. In some embodiments, guidance sensor 123 may include a magnetometer array which may determine the magnitude and orientation of a magnetic field passing therethrough. In some embodiments, the magnetometer array may be a biaxial magnetometer array aligned such that the axes of the magnetometer array are mutually orthogonal and orthogonal to the longitudinal axis of guided wellbore 20. In some embodiments, a triaxial magnetometer array may be utilized. In some embodiments, one or more other sensors such as accelerometers may be included with guidance sensor 123 in order to make additional measurements. By determining the direction at which reference magnetic field B intersects guidance sensor 123 and the magnitude thereof, a distance and heading to reference wellbore 10 from guidance sensor 123 may be determined. By knowing the orientation of guidance sensor 123 with respect to the toolface of guided drilling string 121 and the location of reference wellbore 10 and guided wellbore 20, the direction of the toolface of guided drilling string 121 may be calculated utilizing measurements of reference magnetic field B.

[0018] For the purposes of this disclosure, an xyz coordinate system will be established, wherein the z axis is parallel to the central axis of guided drilling string 121 at guidance sensor 123. The x and y axes are defined as mutually orthogonal and orthogonal to the z axis. In some embodiments, guidance sensor 123 may include a magnetometer aligned with the x and y axes for a biaxial magnetometer or for all three of these axes for a triaxial magnetometer.

[0019] As understood in the art, the magnitude and direction of reference magnetic field B may be calculated at a point away from its source as:

$$\vec{B} = \frac{\mu_0 \vec{I} \times \hat{r}}{2\pi r}$$

where \hat{r} is the heading and distance from reference wellbore 10, and \vec{l} is the current and direction of current i in reference wellbore 10.

[0020] Guidance sensor 123 may take a magnetic field reading within guided wellbore 121, denoted herein as B_{pos} . Because guidance sensor 123 may be exposed to other magnetic fields, such as, for example and without limitation, the magnetic field of the Earth and any nearby cased wellbores or other magnetic anomalies, power supply 101 may reverse current i flowing through reference conductor 109, causing reference magnetic field B to reverse polarity. Guidance sensor 123 may take another reading of reference magnetic field B , denoted herein as B_{neg} . Although designated “positive” and “negative”, one having ordinary skill in the art with the benefit of this disclosure will understand that the first reading may be taken with reference conductor 109 at a positive or negative polarity as long as the two readings are taken at opposite polarities of reference conductor 109. Because any magnetic fields other than B are present for both readings, by finding the difference between B_{pos} and B_{neg} , the magnetic field values of reference magnetic field B may be isolated, according to:

$$\Delta B = B_{pos} - B_{neg}$$

In some embodiments, rather than utilizing positive and negative direct currents, power supply 101 may instead provide periodic or aperiodic alternating currents. In some embodiments, guidance sensor 123 may take a reading of reference magnetic field B with either positive or negative polarity and take a reading of magnetic fields with power supply 101 providing no current to reference conductor 109. In such an embodiment, the detected natural magnetic fields may be similarly subtracted from reference magnetic field B to isolate the magnetic field values of reference magnetic field B .

[0021] The previously described operation may be used for each of the magnetometers in guidance sensor 123. Where the x axis is aligned with the toolface of guided drilling string 121, the angle between toolface and reference wellbore 10 may be determined by:

$$\tau = 90^\circ - \text{atan}\left(-\frac{\Delta B_y}{\Delta B_x}\right)$$

because reference magnetic field B is oriented orthogonally to the vector between reference wellbore 10 and guided wellbore 20.

[0022] The calculated toolface may be referenced to, for example and without limitation, a target location, true or magnetic north, or to gravity high side can be computed by projecting the desired reference direction \vec{q} into the plane perpendicular to the tool axis, as shown by:

$$\vec{q}_\perp = \vec{q} - \vec{q} \cdot \hat{z}\hat{z}$$

where \hat{z} is the axis of guided drilling string 121 in world coordinates:

$$\hat{z} = \begin{bmatrix} \sin(\theta) \cos(\phi) \\ \sin(\theta) \sin(\phi) \\ \cos(\theta) \end{bmatrix}$$

where θ and ϕ are the inclination and azimuth of guided drilling string 121 respectively.

[0023] The offset between the \vec{q} toolface and gravity toolface is given by:

$$\gamma_q = (-q_{\perp y}/q_{\perp x})$$

and the connection between any toolface references can be computed thereby. For example, in the case that reference wellbore 10 and guided wellbore 20 are vertical, with the guided wellbore

placed at a heading of ξ from true north, the correction to a north-referenced azimuthal toolface is given by:

$$\gamma = \xi + \frac{\pi}{2}$$

- [0024] In some embodiments, the distance and heading to reference wellbore 10 may be computed by standard methods. This heading may be used as a toolface for guided drilling string 121, defining an artificial toolface or artificial magnetic toolface. However, as understood in the art, a single measurement of reference magnetic field B cannot simultaneously determine both direction and toolface. In some embodiments, a gradient magnetic field measurement may resolve this ambiguity as can a relative displacement in the horizontal plane.
- 10 [0025] In some embodiments, the direction determination may be improved by including a more detailed geometry of reference wellbore 10, the surveyed geometry of ground lead 103, and the resistivity of ground 15 in the model of reference magnetic field B. The field at the position of guidance sensor 123 may be computed by integrating the Biot-Savart law in differential form over all the power supplies.
- 15 [0026] In some embodiments, the location of ground point 107 may be selected such that it is in the opposite direction from reference wellbore 10 as guided wellbore 20. By using such an arrangement, any magnetic field generated in ground lead 103 may be parallel to reference magnetic field B. The above described distance measurement may be modified to account for any additional magnetic field therefrom. In some embodiments, the effect of any magnetic field generated in ground lead 103 may be accounted for in the magnetic model as discussed
- 20 herein above by knowing the location of ground point 107.

[0027] In some embodiments, as depicted in FIG. 2, artificial toolface reference system 200 may include two ground leads 203a, 203b coupled to power supply 201 through current balancing unit 204. Power supply 201 may supply reference conductor 209 as described herein above with respect to FIG. 1. In other embodiments, separate power supplies 201 may be utilized to power each of ground leads 203a and 203b. Ground leads 203a, 203b may each be coupled to a corresponding grounding point 207a, 207b. In some embodiments, grounding points 207a, 207b may be positioned about reference wellbore 10 such that they extend in substantially opposite directions therefrom. In some embodiments, the effect of any magnetic fields generated in ground leads 203a, 203b may be accounted for in the magnetic model as discussed herein above by knowing the location of ground points 207a, 207b.

[0028] Current balancing unit 204 may, as described in FIG. 3, include variable resistors 205a, 205b and other control circuitry adapted to ensure that equal current is passed through each of ground leads 203a, 203b when returning from ground 15. In this way, each of ground leads 203a, 203b carries half ($i/2$) of the current i provided by power supply 201 into reference conductor 209. By aligning ground leads 203a, 203b, any magnetic fields induced thereby will cancel each other out as depicted in FIG. 2, thus reducing or preventing interference with reference magnetic field B . In some embodiments, ground leads 203a, 203b may be arranged substantially orthogonally to the direction between reference wellbore 10 and guided wellbore 20 (not shown).

[0029] In some embodiments, power supply 101 may supply an AC waveform to ground lead 103 and reference lead 105. In some embodiments, power supply 101 may provide switched DC current to ground lead 103 and reference lead 105. In some embodiments, multiple reference wells 10 having artificial toolface reference systems 100 may be positioned about guided

wellbore 20. In some such embodiments, each artificial toolface reference system 100 may be actuated in sequence or simultaneously.

[0030] When comparing B_{pos} and B_{neg} or the magnetic field determined with power supply 101 turned off, rotation of guided drilling string 121 between measurements may cause error in the calculated toolface. In some embodiments, one or more accelerometers may be used to determine a gravity toolface to determine whether guided drilling string 121 has rotated. However, when in a substantially vertical well, accelerometer derived gravity toolface data may be subject to significant error such as quantization error due to the low inclination angle of guided wellbore 20. The artificial magnetic toolface is not usable for this purpose, as reference magnetic field B causes different values for the determined magnetic toolface when power supply 101 provides positive, negative, or no current.

[0031] In some embodiments, such as if the gravity toolface indicates that a rotation has occurred between measurements, a second set of measurements may be taken with power supply 101 providing positive, negative, or no current, referred to herein as a positive shot, negative shot, and neutral shot respectively, to match the first set of measurements. The determined magnetic toolface based on the second positive shot may be compared with that determined from the first positive shot, that of the second negative shot with the first negative shot, and that of the neutral shot with the first neutral shot. By determining the difference therebetween, it can be determined whether any rotation of guided drill string 121 occurred between measurements. One having ordinary skill in the art with the benefit of this disclosure will understand that although discussed with respect to accelerometers and gravity toolface, other sensors may be used to identify movement of the tool including, for example and without limitation, one or more gyros to determine a gyro toolface.

[0032] The foregoing outlines features of several embodiments so that a person of ordinary skill in the art may better understand the aspects of the present disclosure. Such features may be replaced by any one of numerous equivalent alternatives, only some of which are disclosed herein. One of ordinary skill in the art should appreciate that they may readily use the present disclosure as a basis for designing or modifying other processes and structures for carrying out the same purposes and/or achieving the same advantages of the embodiments introduced herein. One of ordinary skill in the art should also realize that such equivalent constructions do not depart from the spirit and scope of the present disclosure and that they may make various changes, substitutions, and alterations herein without departing from the spirit and scope of the present disclosure.

Claims:

1. An artificial toolface reference system comprising:

a power supply, the power supply providing current to a first ground lead, a second ground lead, and a reference lead;

5 a first ground point, the first ground point coupled to the first ground lead and in electrical connection with the ground;

a second ground point, the second ground point coupled to the second ground lead and in electrical connection with the ground;

10 a reference wellbore, the reference wellbore including a reference conductor in electrical connection with the ground, the reference conductor in electrical connection with the reference lead; and

a guidance sensor positioned outside the reference wellbore including at least one magnetometer.

15 2. The artificial toolface reference system of claim 1, wherein the power supply provides an electric current which passes through the reference lead, the reference conductor, the ground, the first and second grounding points, and the first and second ground leads.

20 3. The artificial toolface reference system of claim 1, wherein the guidance sensor is included in a guided drilling string positioned within a guided wellbore, the guided drilling string including a tool having a reference direction, the angle between the reference direction and the reference wellbore defining a toolface.

4. The artificial toolface reference system of claim 3, wherein the guidance sensor comprises a magnetometer array, and the offset between the reference direction and the axes of the magnetometer is known.
5. The artificial toolface reference system of claim 1, wherein the power supply provides one or more of an AC source or a switched DC source.
6. The artificial toolface reference system of claim 1, wherein the first and second ground leads are coupled to the power supply through a current balancing unit.
7. The artificial toolface reference system of claim 1, further comprising a second power supply, the second power supply electrically coupled between the reference conductor and the second ground lead.
8. The artificial toolface reference system of claim 1, wherein the first and second ground leads extend from the reference wellbore in opposite directions.
9. The artificial toolface reference system of claim 1, wherein the reference lead is coupled to the reference conductor at an upper end of the reference conductor at or near the surface of the ground.
10. The artificial toolface reference system of claim 1, wherein the reference lead is coupled to a wire extending into the reference wellbore and in electrical contact with the reference conductor.
11. The artificial toolface reference system of claim 1, wherein the reference conductor is selected from one or more of a conductive casing, tubing, drill stem, length of drill string, fish, or other downhole tool.

12. The artificial toolface reference system of claim 1, wherein the reference conductor comprises one or more wires or cables extending into the reference wellbore.

13. A method comprising:

5 coupling a power supply between a first and second ground point and a reference conductor, the first and second ground points positioned a distance away from the reference conductor and in electrical communication with the ground, the reference conductor positioned in a reference wellbore and in electrical communication with the ground; the first and second ground points positioned in opposite directions relative to the reference wellbore;

10 providing a current, with the power supply, through the reference conductor, the ground, and the first and second ground points such that a reference magnetic field is generated along the reference conductor; and

 measuring the reference magnetic field with a magnetometer positioned outside of the reference wellbore.

15 14. The method of claim 13, wherein the measuring of the reference magnetic field is carried out by a guidance sensor including at least one magnetometer.

15. The method of claim 14, wherein the guidance sensor is included as part of a guided drilling string positioned in a guided wellbore.

16. The method of claim 15, wherein the magnitude and direction of reference magnetic field may be calculated at a point away from its source as:

$$\vec{B} = \frac{\mu_0 \vec{I} \times \hat{r}}{2\pi r}$$

where \hat{r} is the heading and distance from the reference wellbore, and \vec{I} is the current and direction of current i in the reference wellbore.

5 17. The method of claim 15, further comprising:

reversing a polarity of the power supply such that a negative reference magnetic field is generated along the reference conductor;

measuring the negative reference magnetic field with the magnetometer; and

10 subtracting the measured reference magnetic field from the negative reference magnetic field such that the reference magnetic field is isolated from any other magnetic fields.

18. The method of claim 15, further comprising:

deactivating the power supply;

measuring any other magnetic fields with the magnetometer; and

15 subtracting the measured other magnetic fields from the measured reference magnetic field such that the reference magnetic field is isolated from the other magnetic fields.

19. The method of claim 15, wherein the magnetometer is a triaxial magnetometer corresponding to x, y, and z axes wherein the z axis is aligned with the guided wellbore and the x and y axes are mutually orthogonal and orthogonal to the z axis.

20. The method of claim 19, wherein the guided drill string further comprises a directional tool having a reference direction, the angle between the reference direction and the reference wellbore defining a toolface.

21. The method of claim 20, wherein the orientation of the toolface relative to the guidance sensor is known.

22. The method of claim 21 wherein the angle between the toolface and the reference wellbore is given by:

$$\tau = 90^\circ - \text{atan}\left(-\frac{\Delta B_y}{\Delta B_x}\right).$$

23. The method of claim 22, further comprising referencing the calculated toolface to a desired reference direction according to:

$$\vec{q}_\perp = \vec{q} - \vec{q} \cdot \hat{z}\hat{z}$$

where \vec{q} is the desired reference direction, \hat{z} is the axis of the guided drilling string in world coordinates:

$$\hat{z} = \begin{bmatrix} \sin(\theta) \cos(\phi) \\ \sin(\theta) \sin(\phi) \\ \cos(\theta) \end{bmatrix}$$

where θ and ϕ are the inclination and azimuth of the guided drilling string respectively.

24. The method of claim 15, further comprising:

providing a second current, with the power supply, through the reference conductor, the ground, and the first and second ground points such that a second reference magnetic field is generated along the reference conductor, the second current substantially

5 the same as the first current;

measuring the second reference magnetic field with the magnetometer;

comparing the measured first reference magnetic field and the measured second reference magnetic field; and

10 determining if any movement of the guided tool string occurred between the first measurement and the second measurement.

2/3

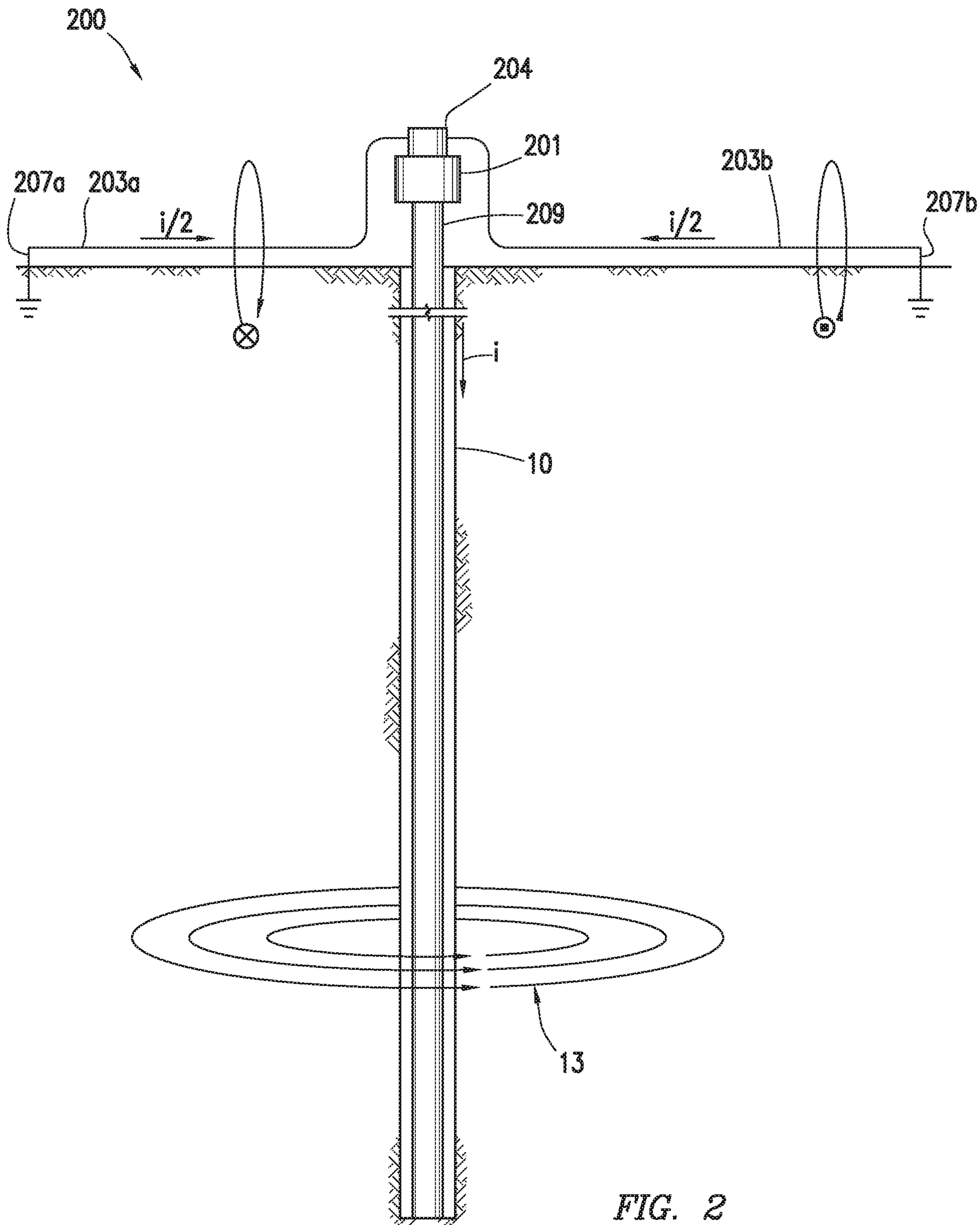

FIG. 2

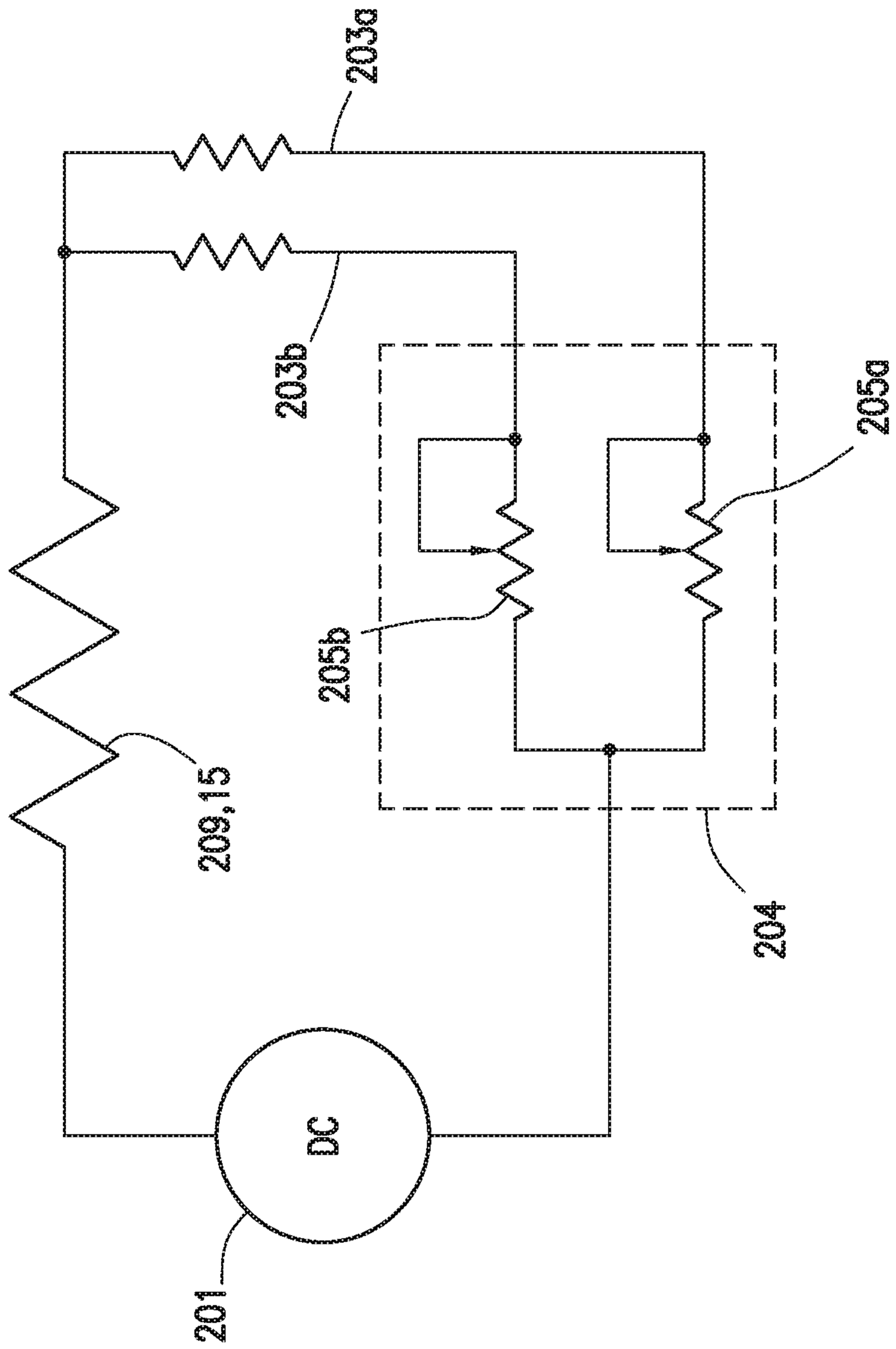

FIG. 3

