



US007003124B1

(12) **United States Patent**  
**Thiel**

(10) **Patent No.:** **US 7,003,124 B1**

(45) **Date of Patent:** **Feb. 21, 2006**

(54) **SYSTEM AND METHOD FOR ADJUSTING FREQUENCY RESPONSE CHARACTERISTICS OF HIGH-PASS CROSSOVERS SUPPLYING SIGNAL TO SPEAKERS USED WITH SUBWOOFERS**

(58) **Field of Classification Search** ..... 381/99, 381/100, 98, 103, 101, 102, 59, 97, 96  
See application file for complete search history.

(56) **References Cited**

**U.S. PATENT DOCUMENTS**

5,617,480 A *	4/1997	Ballard et al. ....	381/98
5,930,374 A *	7/1999	Werrbach et al. ....	381/99
6,317,117 B1 *	11/2001	Goff .....	381/98
6,405,227 B1 *	6/2002	Prakash .....	708/300
6,606,388 B1 *	8/2003	Townsend et al. ....	381/99
6,674,864 B1 *	1/2004	Kitamura .....	381/99
6,775,385 B1 *	8/2004	Coombs .....	381/99

\* cited by examiner

*Primary Examiner*—Stella Woo

(74) *Attorney, Agent, or Firm*—Thomas, Kayden, Horstemeyer & Risley

(75) **Inventor:** **James Thiel**, Lexington, KY (US)

(73) **Assignee:** **Thiel Audio Products**, Lexington, KY (US)

(\*) **Notice:** Subject to any disclaimer, the term of this patent is extended or adjusted under 35 U.S.C. 154(b) by 895 days.

(21) **Appl. No.:** **09/838,952**

(22) **Filed:** **Apr. 20, 2001**

**Related U.S. Application Data**

(60) Provisional application No. 60/207,792, filed on May 30, 2000.

(51) **Int. Cl.**  
**H03G 5/00** (2006.01)

(52) **U.S. Cl.** ..... 381/99

(57) **ABSTRACT**

A system and method for adjusting the frequency response of a main speaker system used in conjunction with a subwoofer by modifying the input signal in response to user-adjustable settings to compensate for main-speaker effects characteristics in order to produce a desirable blend of the subwoofer sonic output and the main-speaker sonic output.

**5 Claims, 16 Drawing Sheets**

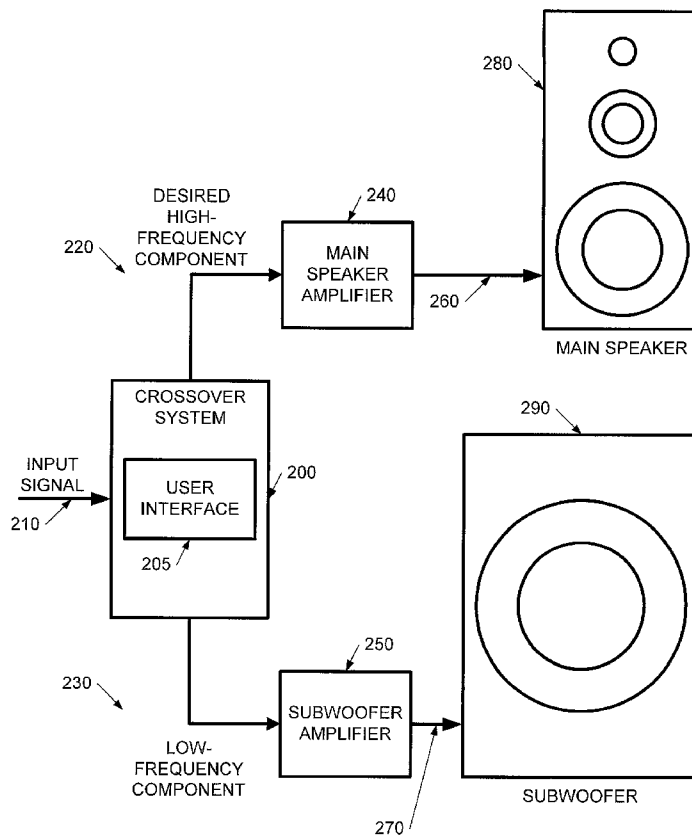

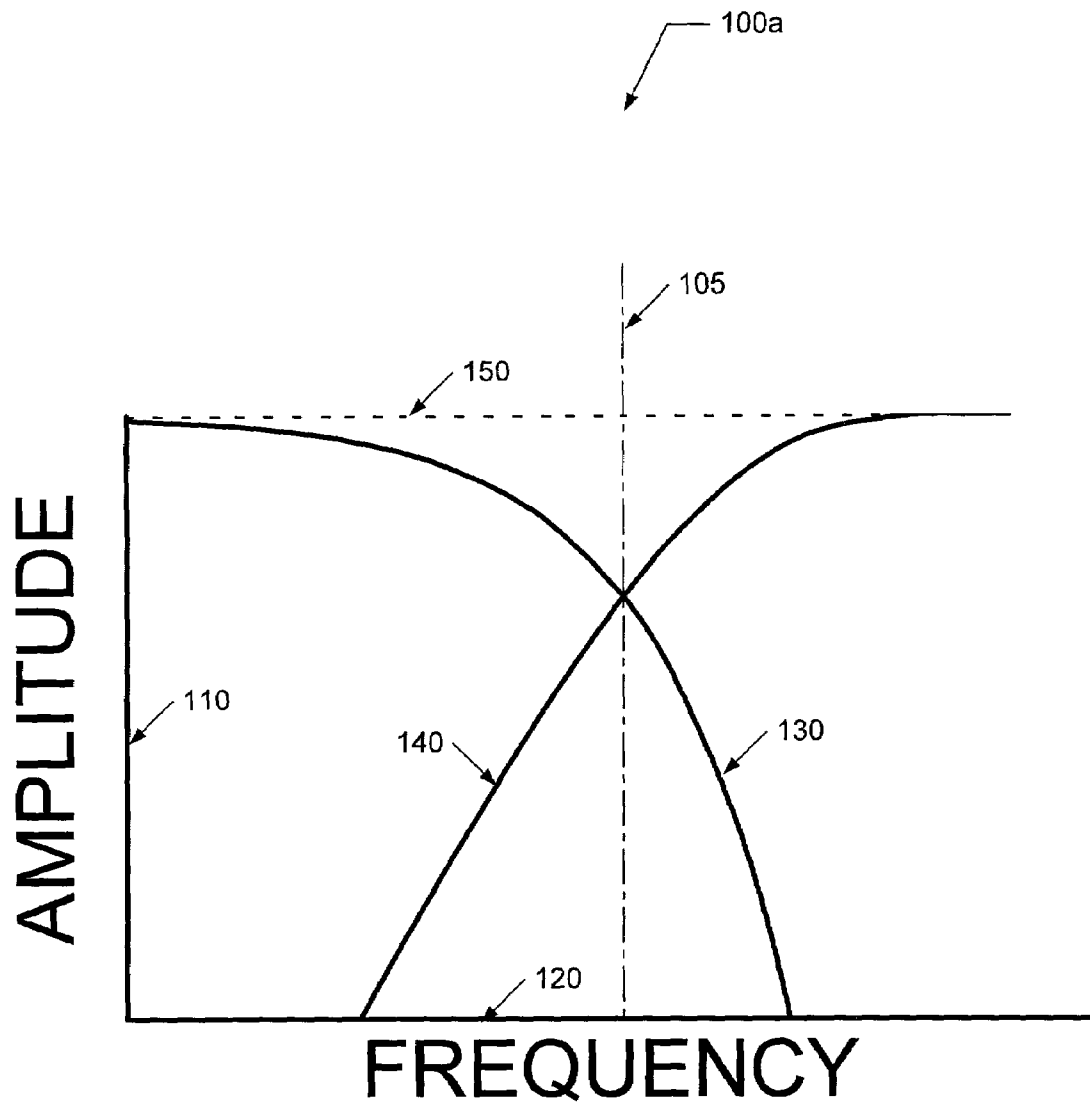

FIG. 1A

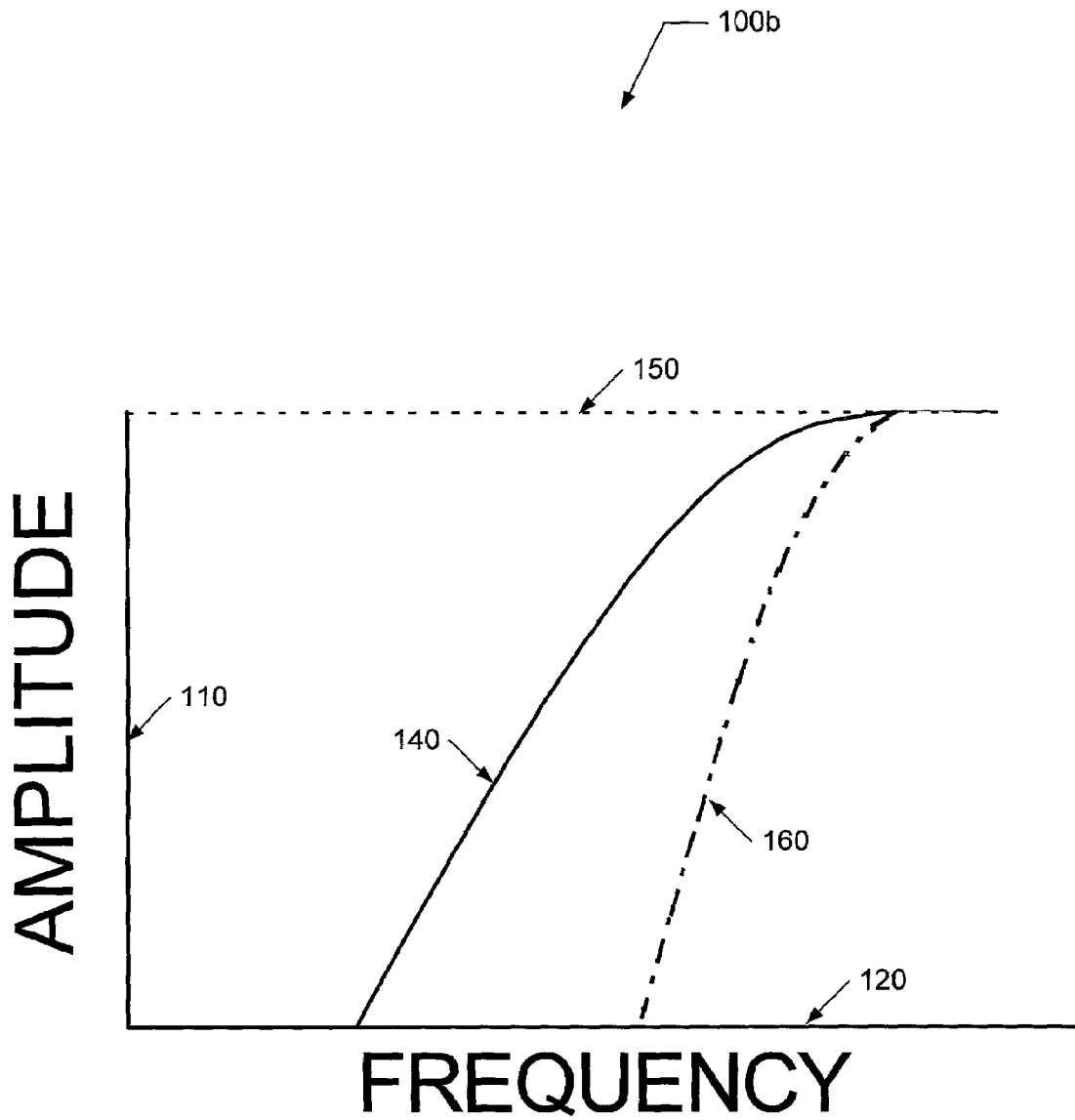

FIG. 1B

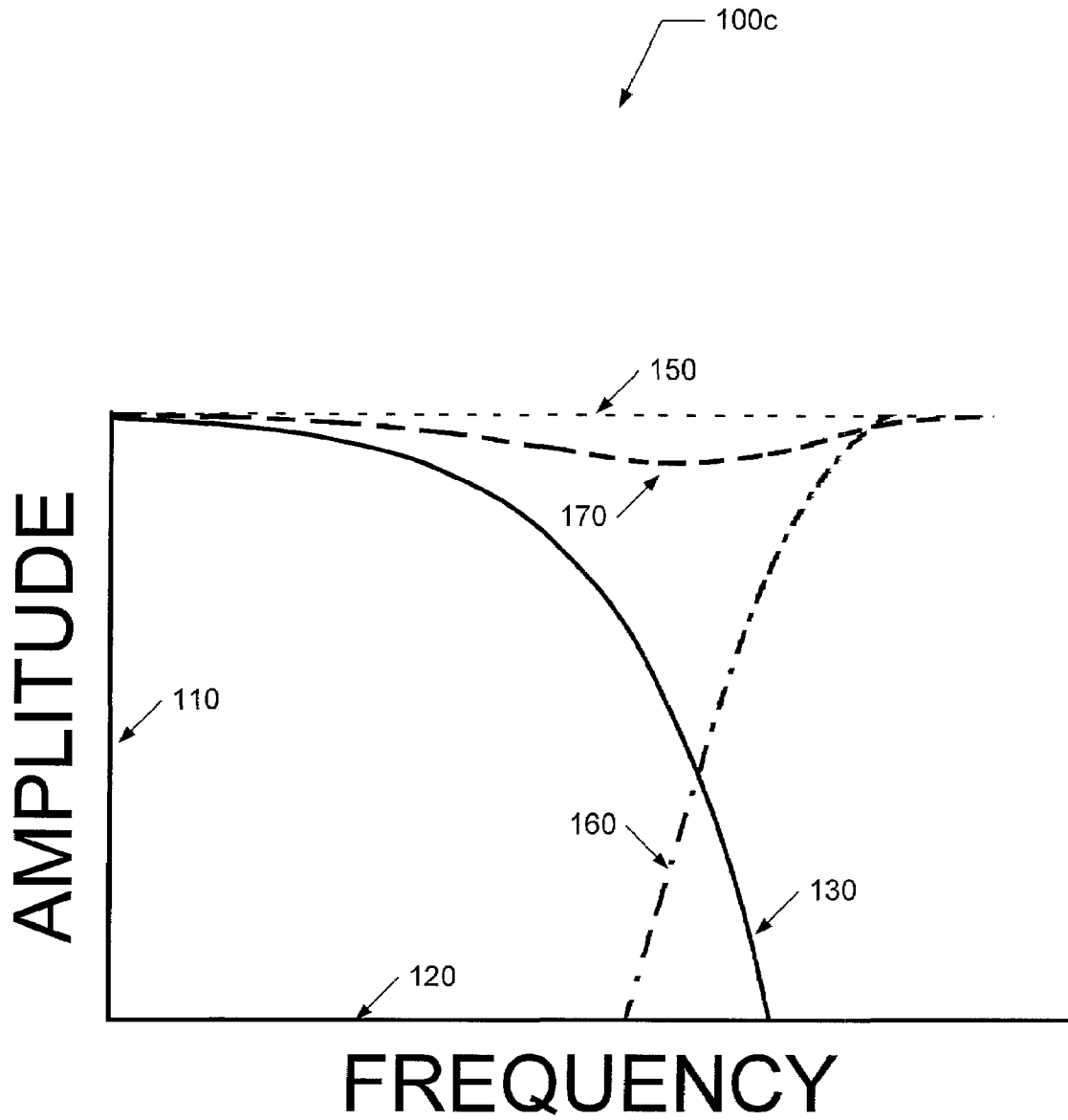

FIG. 1C

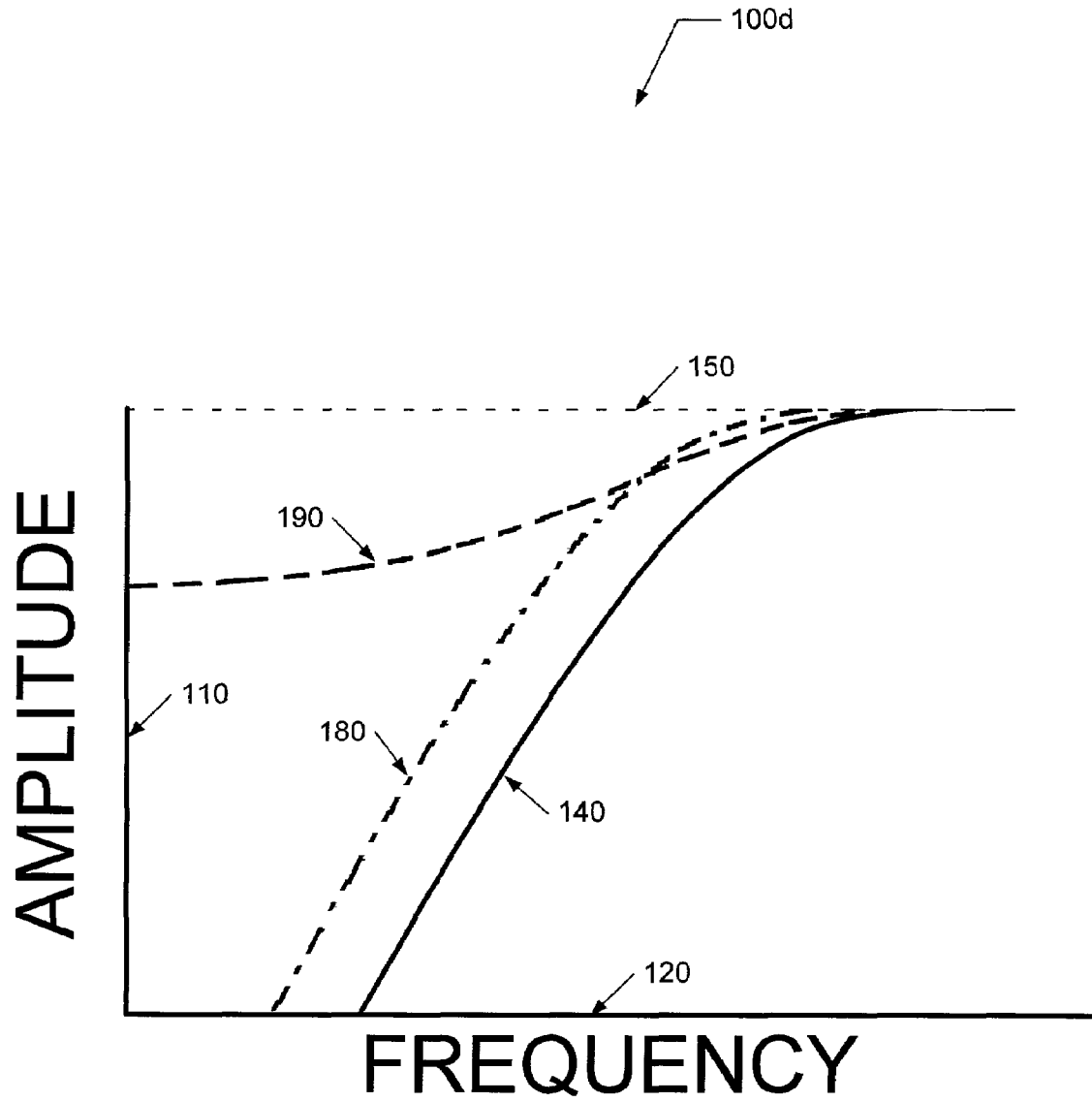

FIG. 1D

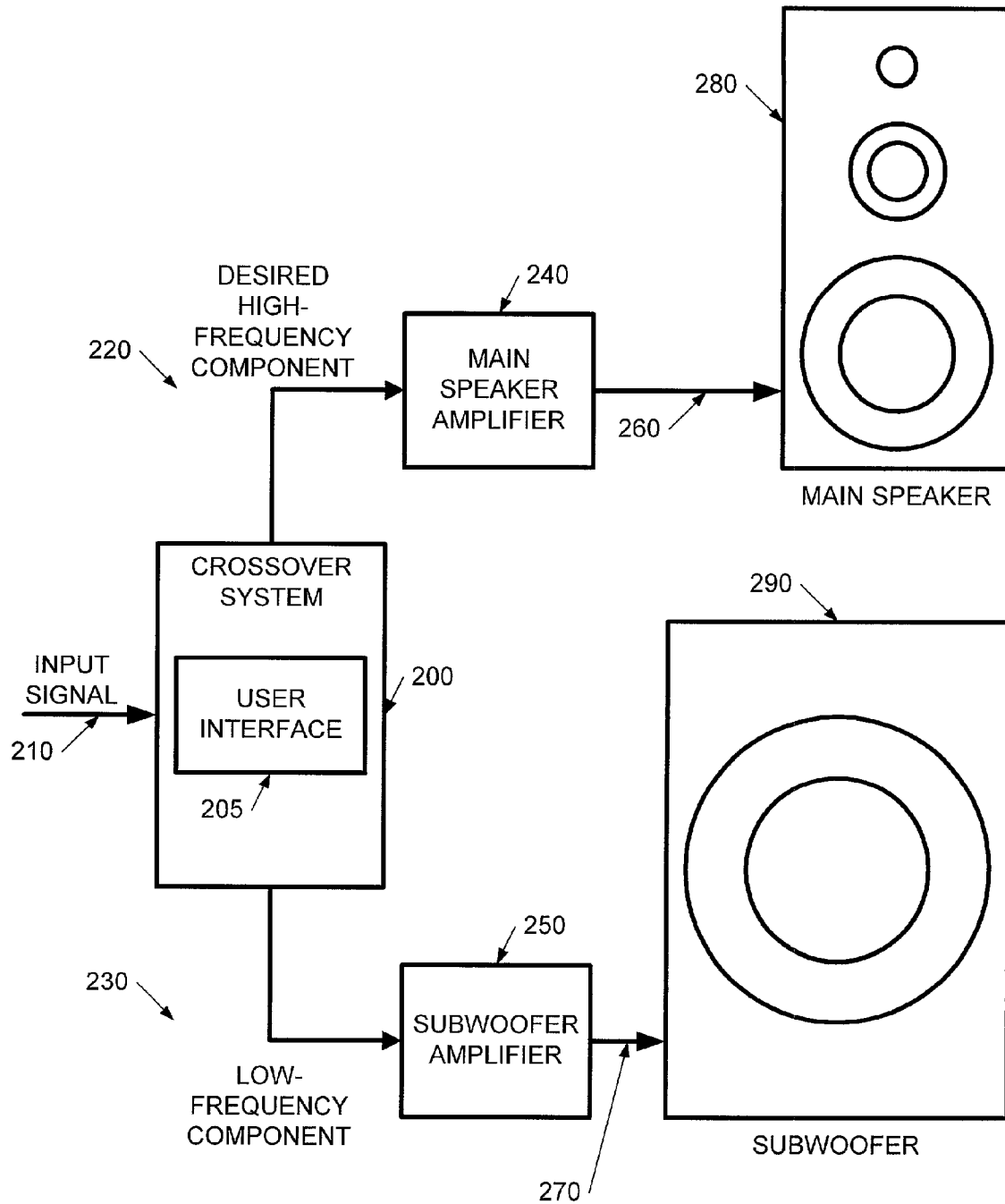

FIG. 2

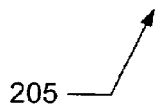
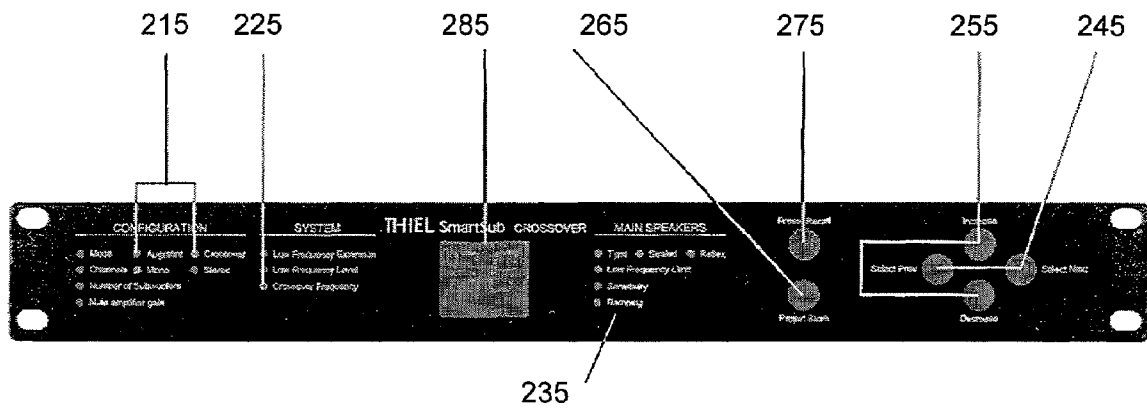
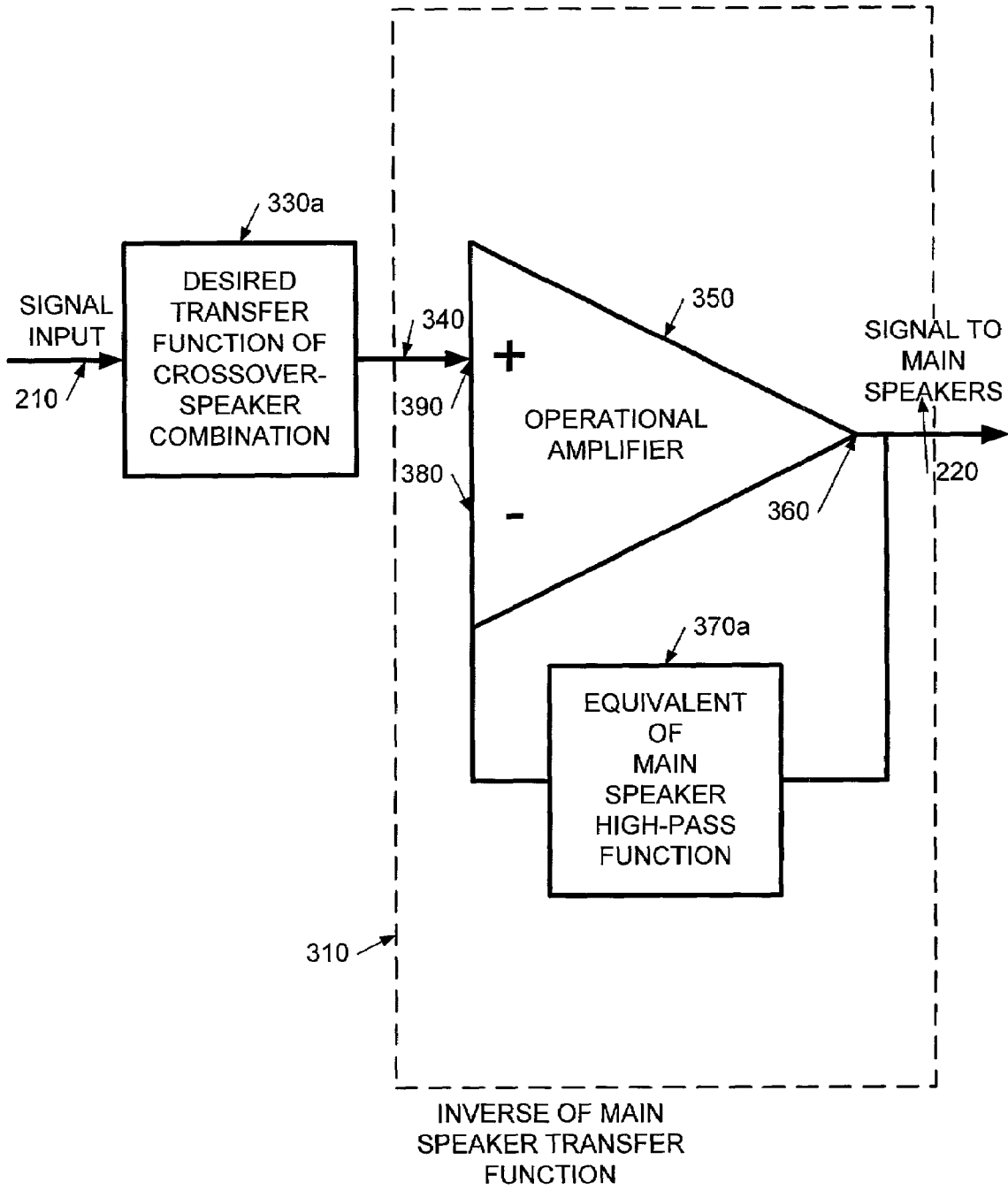
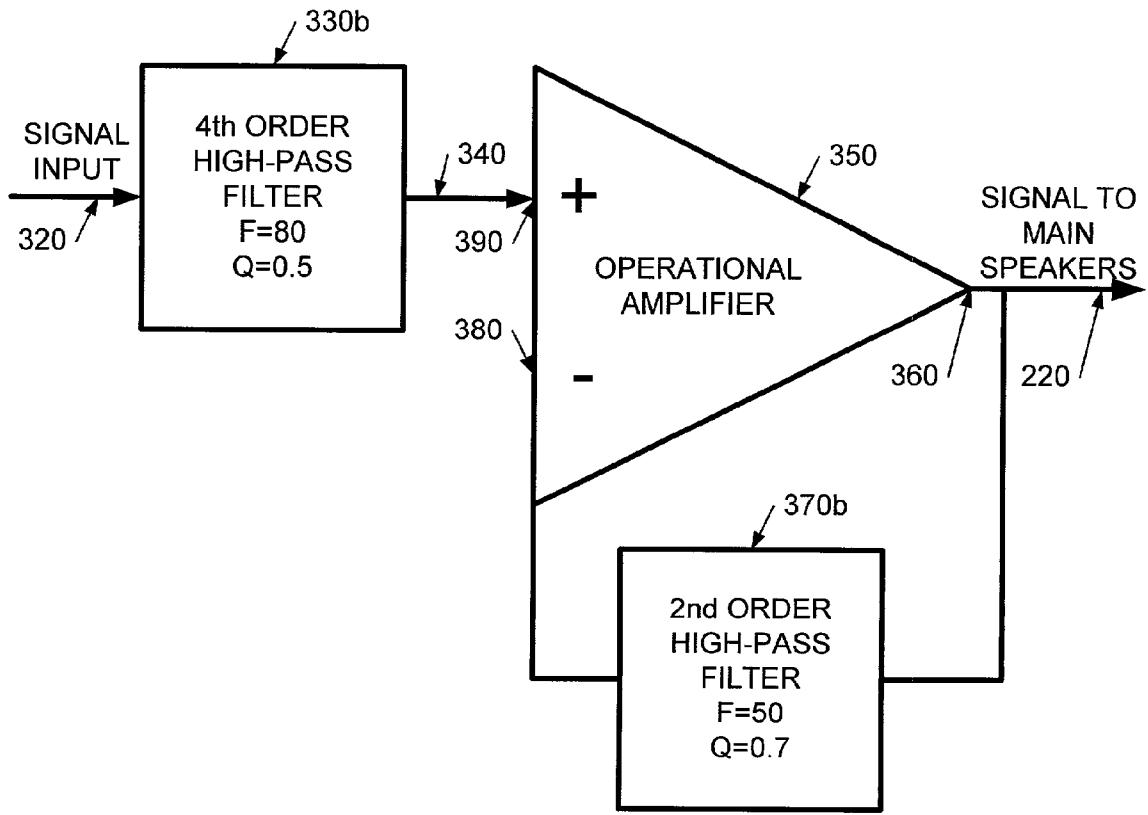

FIG. 3



300a ↗

**FIG. 4A**



300b ↗

**FIG. 4B**

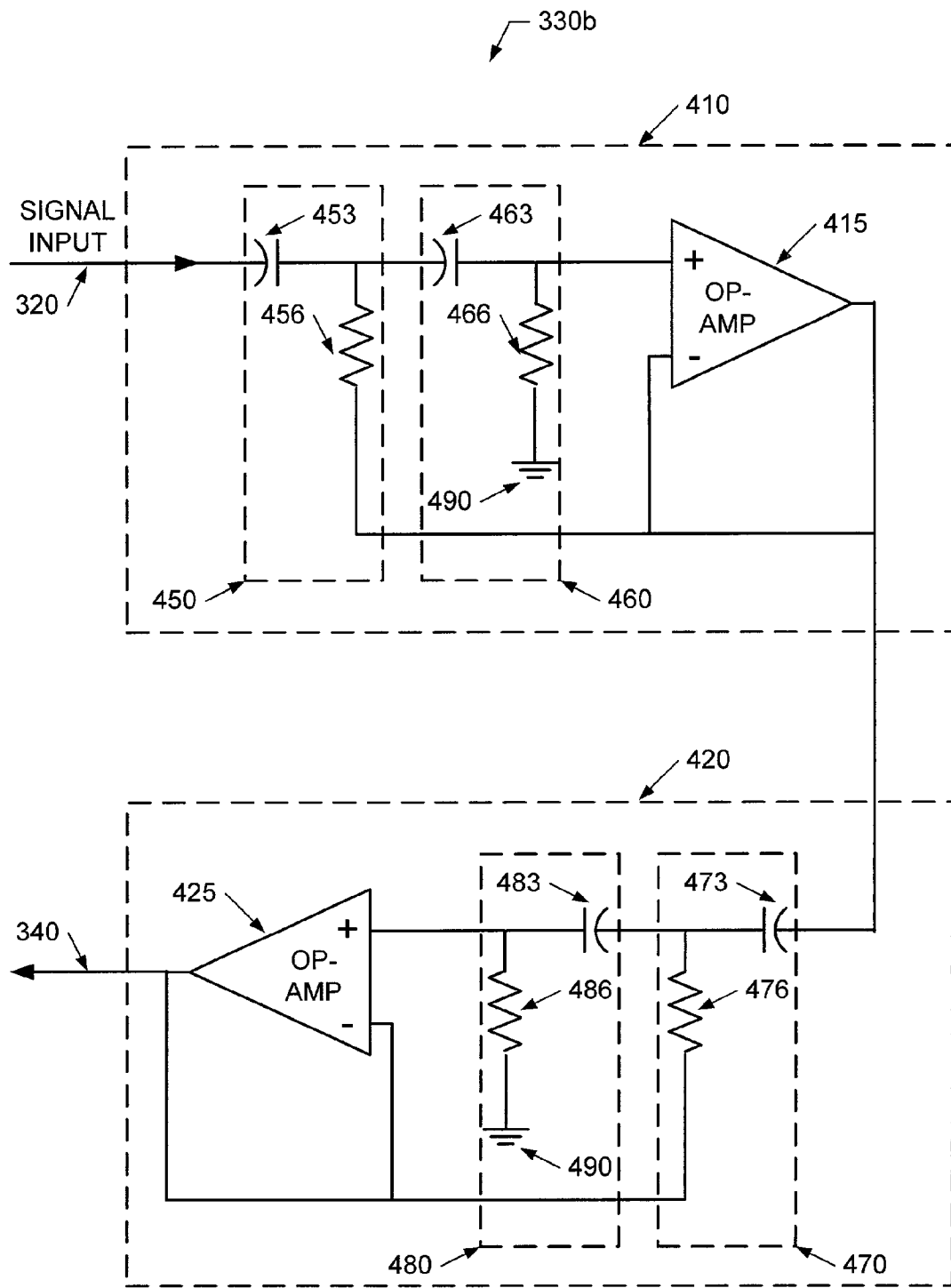

FIG. 5A

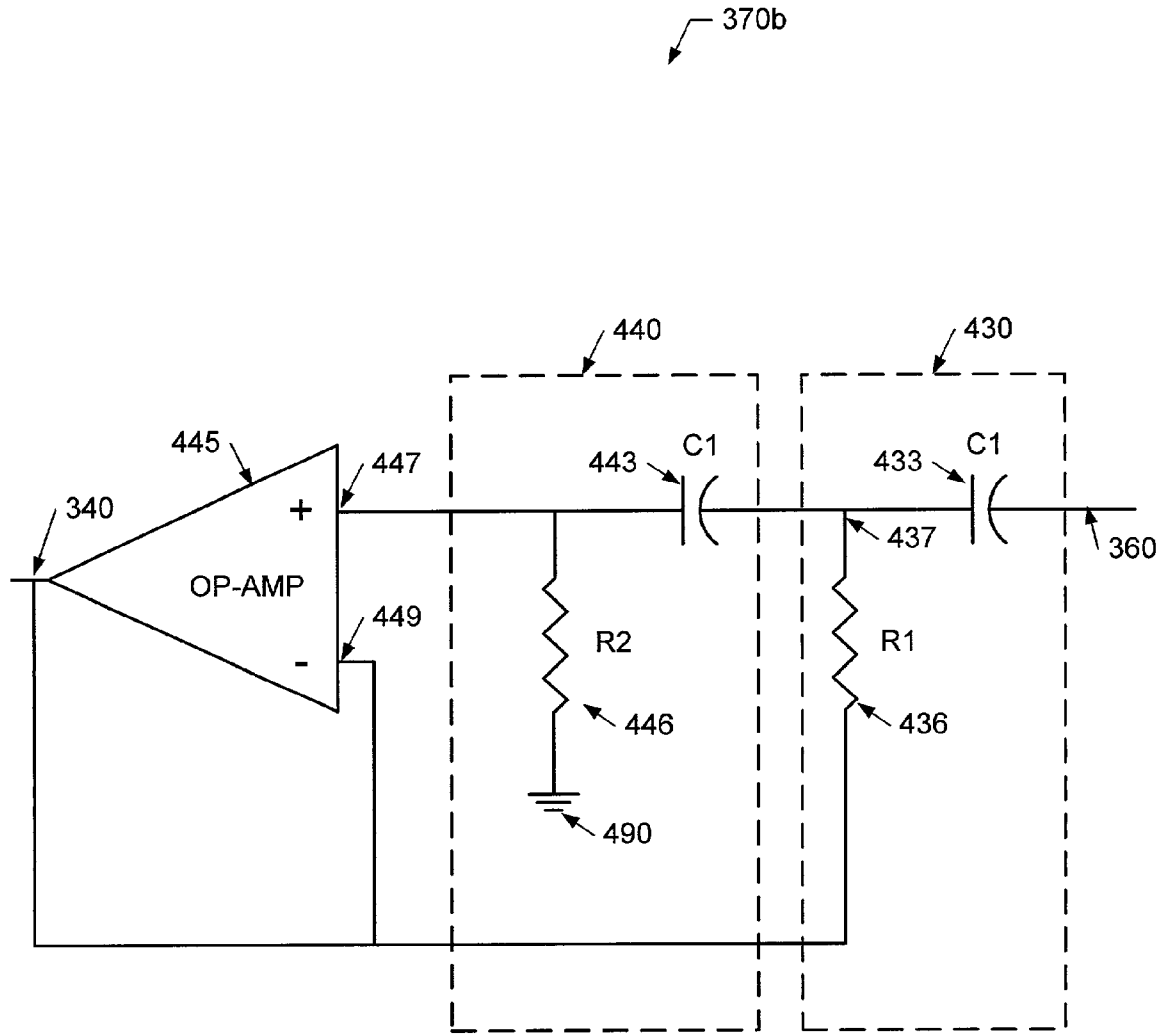

FIG. 5B

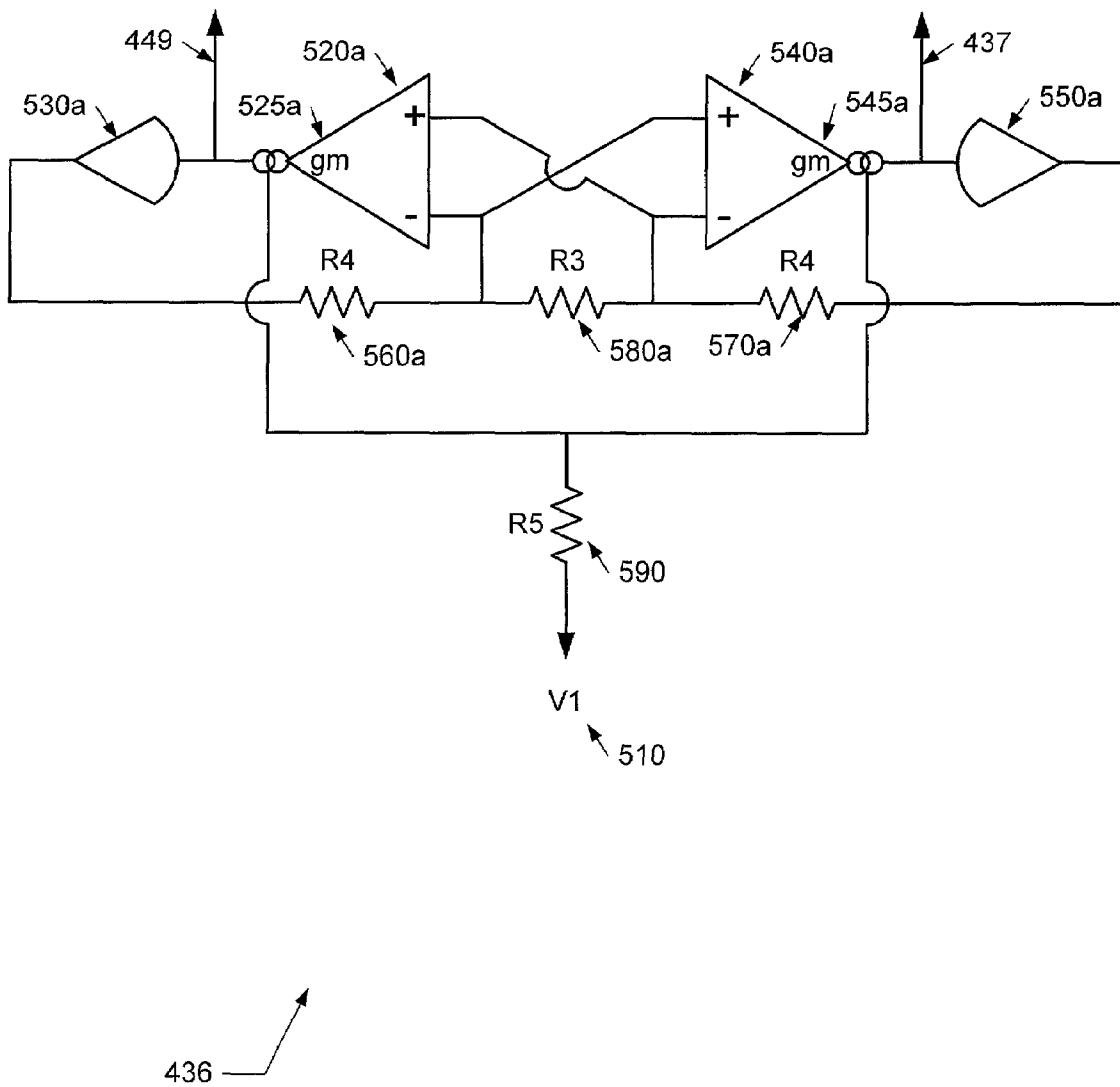

FIG. 6A

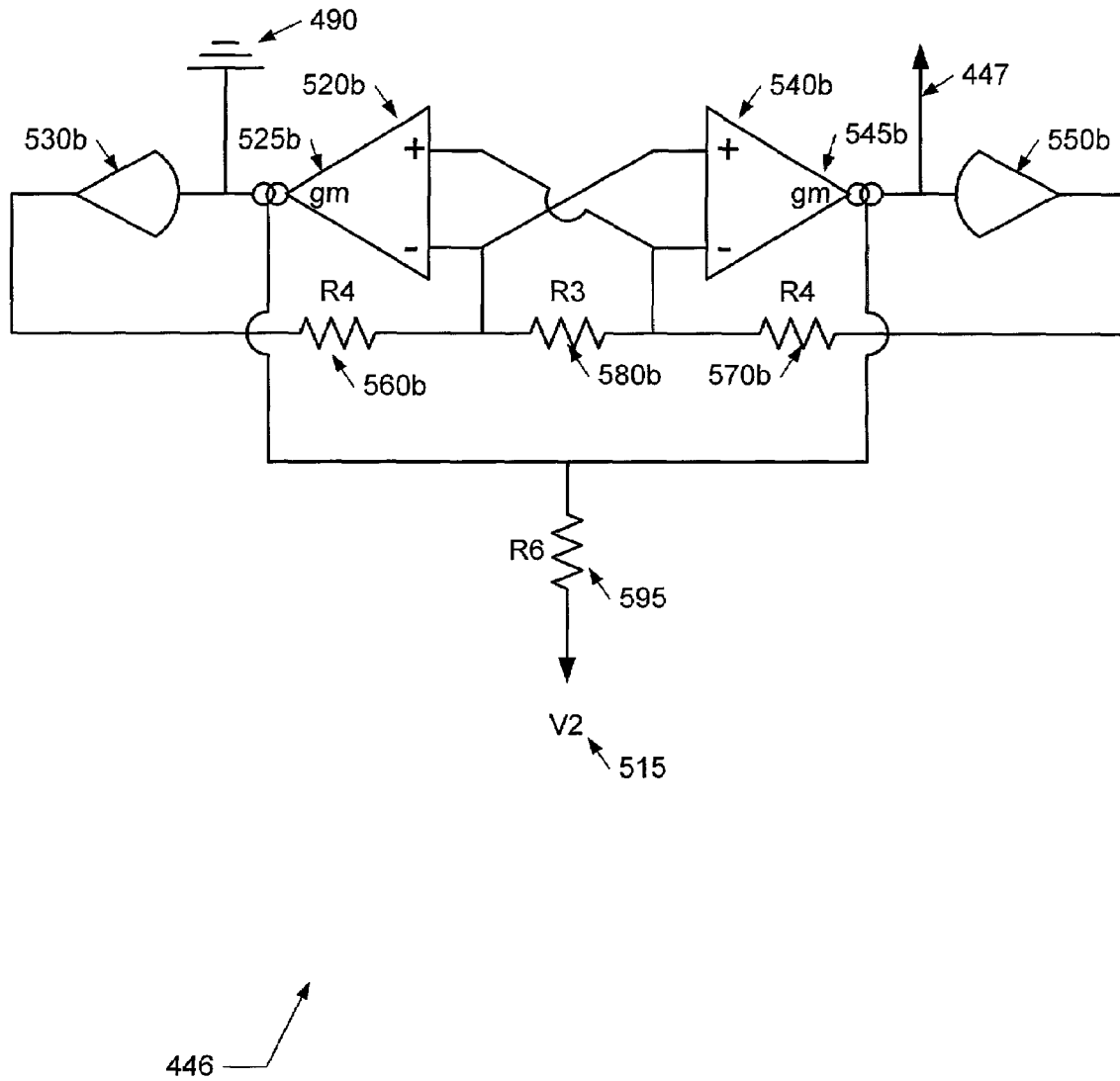

FIG. 6B

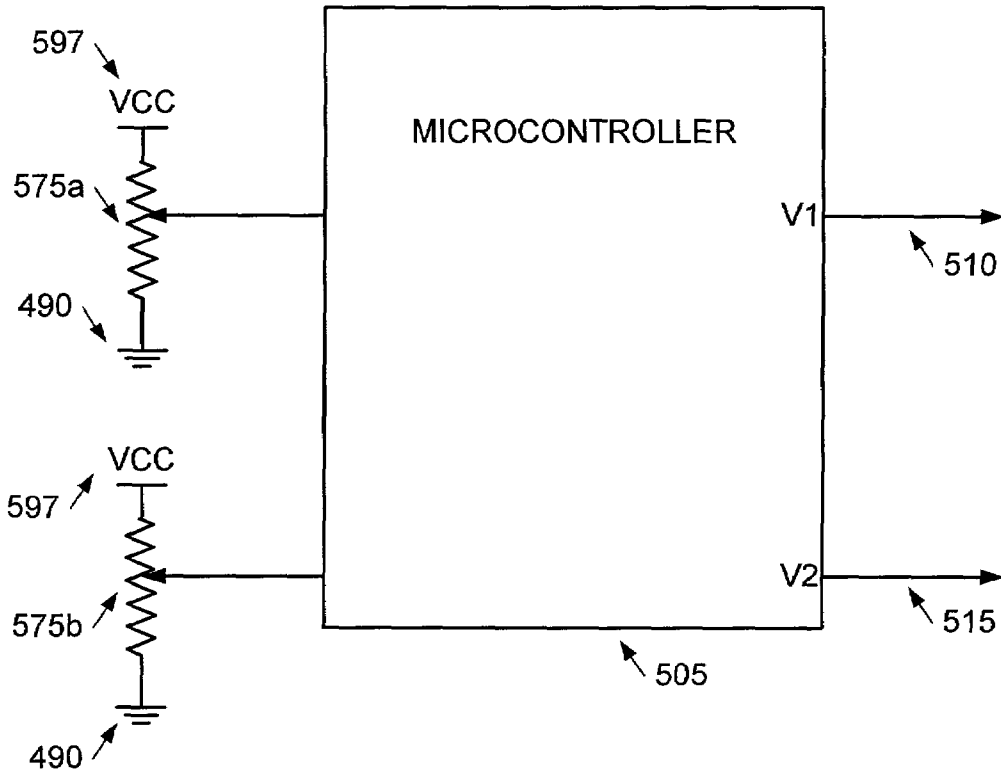
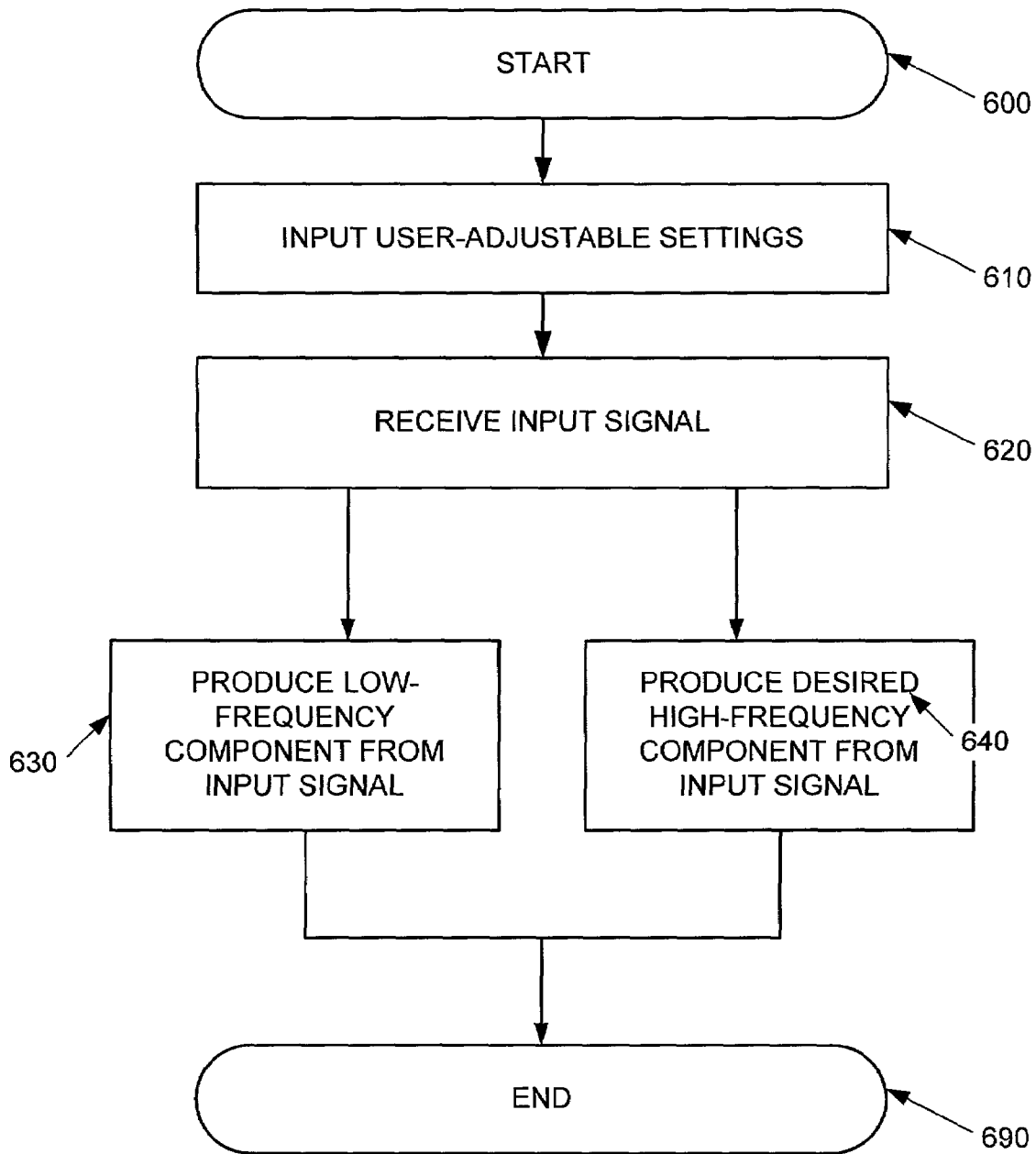
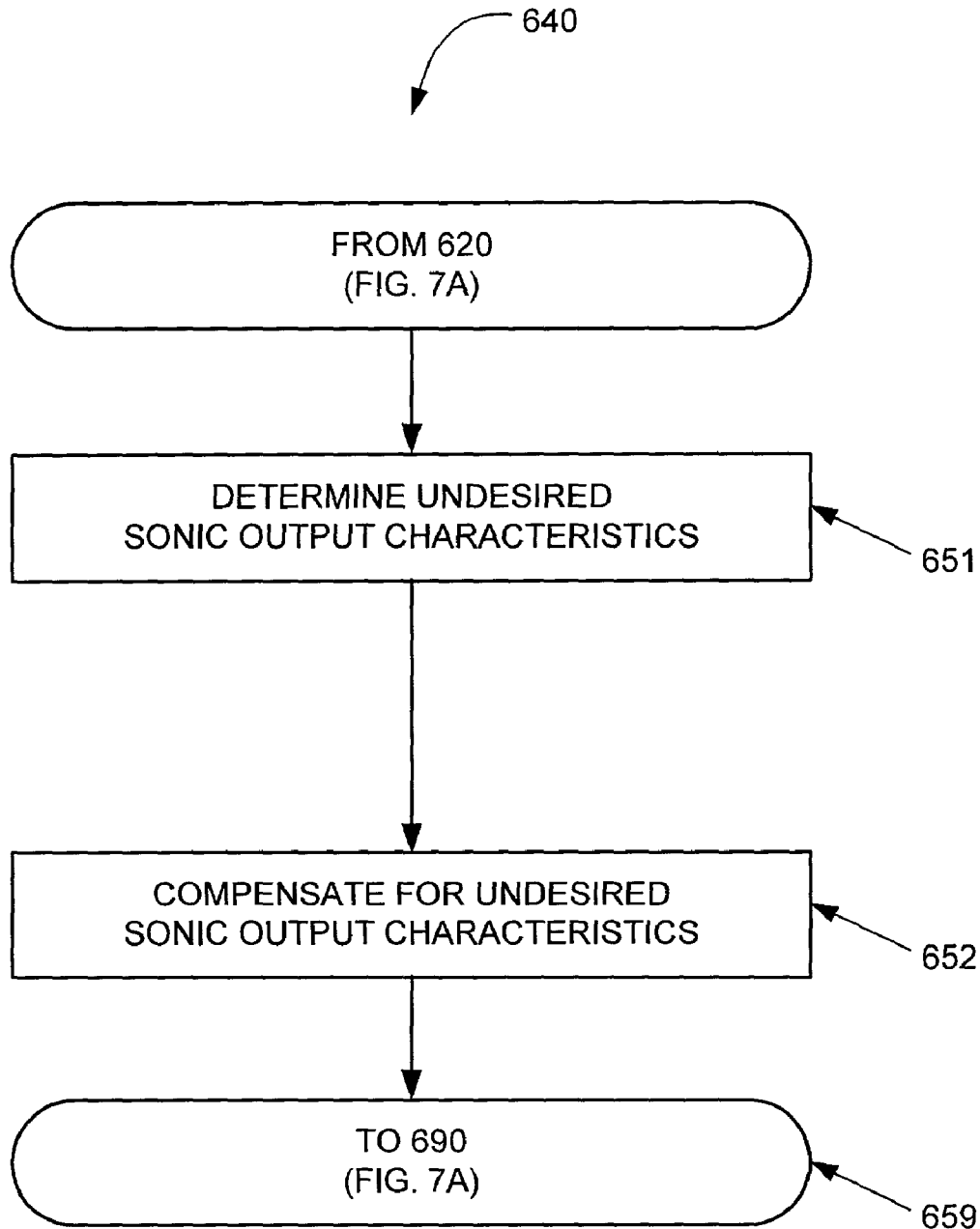

FIG. 6C



**FIG. 7A**



**FIG. 7B**

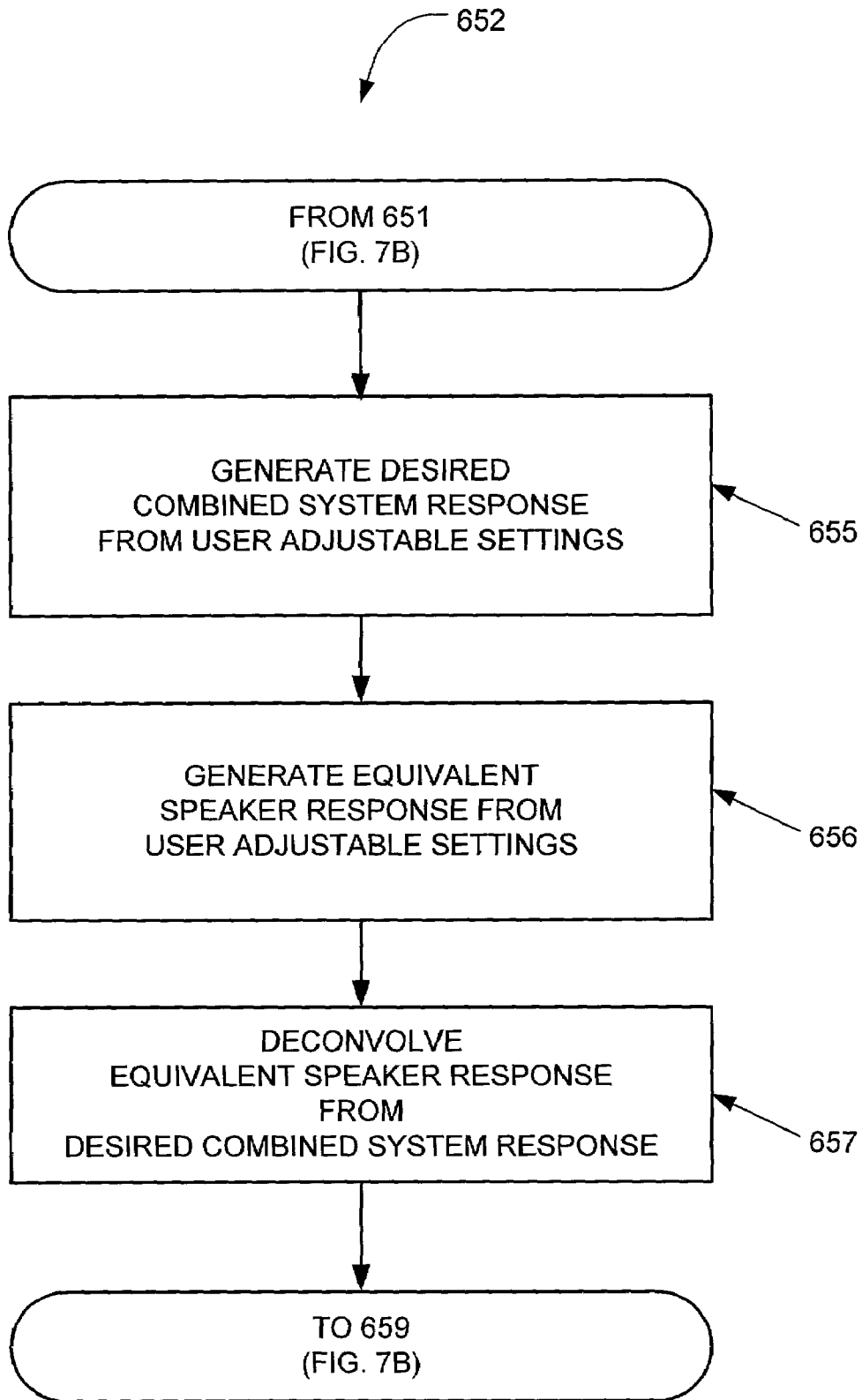

**FIG. 7C**

**SYSTEM AND METHOD FOR ADJUSTING  
FREQUENCY RESPONSE  
CHARACTERISTICS OF HIGH-PASS  
CROSSOVERS SUPPLYING SIGNAL TO  
SPEAKERS USED WITH SUBWOOFERS**

CROSS REFERENCE TO RELATED  
APPLICATIONS

This application claims the benefit of U.S. Provisional Patent Application No. 60/207,792; dated May 30, 2000, which is incorporated herein by reference in its entirety.

FIELD OF INVENTION

This invention relates generally to loudspeakers, and more particularly to crossovers used to divide the audio signal between subwoofer speakers and main speakers in a sound reproduction system.

BACKGROUND

As is well known, a loudspeaker receives an electrical signal representing an audio sound, and converts the electrical signal to an audio sound wave via a loudspeaker driver unit. The driver unit comprises, in part, a motor that responds to the electrical signal to move a diaphragm. The movement of the diaphragm perturbs the surrounding air, which causes the audio wave.

Due to inadequate low-frequency characteristics, many loudspeakers do not respond well to input signals of very low frequencies (i.e., the bass or lower register). Thus, a high quality audio system may include a separate, specialized speaker, termed a subwoofer, which is designed to more accurately reproduce the lower frequencies of the full sound spectrum. In some instances, a subwoofer is used in conjunction with a crossover. The crossover separates, with respect to a (usually user-definable) crossover frequency, the full sound spectrum into low-frequency components (i.e., those signals that are below a crossover frequency) and high-frequency components (i.e., those signals that are above a crossover frequency). The crossover then directs the low-frequency components to the subwoofer and the high-frequency components to the main speaker. The crossover's high-pass response is intended to complement the low-pass response characteristics of the subwoofer, hence, achieving a desirable blending of the sonic output of the main speaker and the subwoofer. Although the use of a crossover-subwoofer system provides improved sound quality, further improvements are desired.

SUMMARY

The present invention provides a system and method for accurately reproducing audio sounds by adjusting the high-pass characteristics of a crossover system to account and compensate for the frequency response characteristics of a main speaker.

Briefly described, a user supplies information relating to the low frequency response characteristics of a main speaker to the crossover system by adjusting user-adjustable settings. The crossover system receives an input audio signal and produces a low-pass component and a high-pass component of the input signal. The high-pass component of the signal is generated with respect to the user-adjustable settings. This high-pass component, when cascaded through an amplifier and a main speaker, produces a high-frequency

output that, when combined with the low-frequency output of the subwoofer, results in a combined main speaker/subwoofer system with a more desirable sonic output (i.e., a higher quality sound).

In architecture, the system comprises a crossover configured to receive user-adjustable settings, which are indicative of main speaker characteristics. The crossover is further configured to produce a high-frequency signal from the input signal as a function of these user-adjustable settings. This high-frequency signal, when delivered through an amplifier and main speaker, produces a main speaker sonic output that is complementary to the subwoofer's sonic output to produce the desired blending of low-frequency and high-frequency sounds.

In accordance with another aspect of the present invention, a method is provided for adjusting the frequency response of a speaker to produce a desired high-frequency output. The method can be broadly conceptualized as receiving an input signal and user-adjustable settings, and generating a high-pass signal from the input signal as a function of the user adjustable settings. The generated high-pass signal, when cascaded through an amplifier and main speaker, produces a main speaker sonic output that is complementary to the subwoofer's sonic output to produce the desired combined sonic output.

Other systems, methods, features, and advantages of the invention will be or become apparent to one with skill in the art upon examination of the following figures and detailed description. It is intended that all such additional systems, methods, features, and advantages be included within the scope of the invention, and be protected by the accompanying claims.

BRIEF DESCRIPTION OF THE DRAWINGS

The above and further features, advantages, and benefits of the present invention will be apparent upon consideration of the following detailed description, taken in conjunction with the accompanying drawings, in which like reference characters refer to like parts throughout.

FIG. 1A is a frequency response plot showing an ideal response of a combined speaker and subwoofer system.

FIG. 1B is a frequency response plot showing a desired response of a main speaker and an actual combined crossover-speaker response.

FIG. 1C is a frequency response plot showing an actual response of a combined crossover-speaker and a subwoofer.

FIG. 1D is a frequency response plot showing a response of a compensation circuit to achieve the desired speaker response from the actual speaker response.

FIG. 2 is a simplified block diagram showing a crossover system in relation to components of a typical audio system.

FIG. 3 is a diagram of a front panel of the preferred crossover system.

FIG. 4A is a block diagram showing a simplified architecture of the invention having a desired transfer function and a known speaker transfer function.

FIG. 4B is a block diagram showing an example system of FIG. 4A having a 4<sup>th</sup>-order high-pass system as the desired transfer function and a 2<sup>nd</sup>-order high-pass system as the speaker transfer function.

FIG. 5A is a circuit diagram showing the 4<sup>th</sup>-order high-pass system of FIG. 4B.

FIG. 5B is a circuit diagram showing the 2<sup>nd</sup>-order high-pass system of FIG. 4B.

FIG. 6A is a circuit diagram showing an equivalent-resistance circuit that can be used for the first resistance in FIG. 5B.

FIG. 6B is a circuit diagram showing an equivalent-resistance circuit that can be used for the second resistance in FIG. 5B.

FIG. 6C is a block diagram showing a microcontroller circuit for providing a control voltage to the equivalent resistances of FIGS. 5A and 5B.

FIG. 7A is a flow chart showing the operation of the crossover system of FIG. 4A.

FIG. 7B is a flow chart showing the modification of the high-frequency component of FIG. 7A to produce a pre-adjusted high-pass signal.

FIG. 7C is a flow chart showing, in greater detail, the method of compensating for the undesired sonic output of FIG. 7B.

### DETAILED DESCRIPTION OF DRAWINGS

Having summarized various aspects of the present invention, reference will now be made in detail to the description of the invention as illustrated in the drawings. While the invention will be described in connection with these drawings, there is no intent to limit it to the embodiment or embodiments disclosed therein. On the contrary, the intent is to cover all alternatives, modifications, and equivalents included within the spirit and scope of the invention as defined by the appended claims.

#### Theory

The normal audible sound spectrum consists of a frequency range from approximately 20 Hz up to approximately 20 kHz. Since speakers in a typical stereo system do not have a uniform frequency response to the lowest parts of the audible sound range, different frequency components of the sound range are handled by different speakers having a desired frequency response for a given frequency range. An example of this is given in FIG. 1A, which is a frequency response plot showing the high-frequency and low-frequency components of a signal. Ideally, a crossover system divides a uniform input signal **150** into a high-frequency response **140** having frequencies above a given crossover frequency **105** and a low-frequency response **130** having frequencies below a given crossover frequency **105**. The high-frequency response **140** is amplified through a main speaker amplifier while the low-frequency response **130** is amplified through a subwoofer amplifier. The signal from the main speaker amplifier is then channeled through a main speaker which, ideally, provides sound output identical to the high-frequency response **140** from the crossover system. Similarly, the signal from the subwoofer amplifier is channeled through a subwoofer which, ideally, provides sound output identical to the low-frequency response **130** from the crossover system. In other words, in an ideal system, the low-frequency response **130** and the high-frequency response **140** of the crossover system would pass through the main speaker and subwoofer undistorted, thereby producing a low-frequency response and a high-frequency response that accurately represents of the high-frequency response **140** and the low-frequency response **130** from the crossover system. Hence, the ideal combined response from the main speaker and the subwoofer would be an accurate representation of the uniform input signal **150**.

FIG. 1B is a plot **100b** comparing an ideal main speaker response **140** and an actual crossover-speaker response **160**. As mentioned above, it would be desirable to have a main

speaker that accurately produces the high-frequency response **140** of the uniform input signal **150**. However, in reality, the main speaker typically does not have a uniform frequency response over the range near or below the crossover frequency **105** (FIG. 1A). Thus, the high-frequency response of the input signal **150**, when passed through the crossover and main speakers, produces a non-ideal crossover-speaker response **160** that has different characteristics from that of the ideal high-frequency response **140**.

FIG. 1C is an actual frequency response plot **100c** of the actual combined response **170** of a non-ideal crossover-speaker response **160** and a subwoofer response **130**. Since the actual crossover-speaker response **160** has different frequency characteristics than the ideal response **140** (FIG. 1A), the combination of the actual crossover-speaker response **160** and the low-frequency response **130** produces a non-uniform frequency response **170** that deviates from the ideal combined sonic output **150**. This deviation from the ideal sonic output produces an undesirable blending of sounds.

In order to compensate for the undesirable blending of sounds, it is possible to generate a desired high-frequency signal, which, when channeled through the main speaker, would produce a blending of sound. FIG. 1D shows a crossover high-pass response **190** that can be combined with the actual speaker response **180** to produce the desired high-pass speaker response **140**. If the response of the main speaker is known, it may be used to generate a high-pass crossover system response **190** that, when combined with the actual response of the main speaker, will produce the desired response **140**.

The present invention provides a system and method for generating a high-frequency response from a crossover system to produce a desired speaker response **140**. The details of the invention, discussed below, are not to be taken in a limiting sense but are made merely for the purpose of describing the general principles of the invention. The scope of the invention should be ascertained with reference to the issued claims.

#### Crossover System for Pre-Adjusting a High-Frequency Component of an Input Signal to Produce a Desired High-Frequency Sonic Output

Turning now to the system of the invention, FIG. 2 shows a high-level diagram of a speaker system constructed in accordance with the invention. The speaker system includes the crossover system **200** of the invention designed to compensate for the frequency response of a main speaker **280** (i.e., to implement the compensation technique discussed above). The crossover system **200** comprises a user interface **205** that allows a user to input various parameters related to the main speaker **280**. These parameters reflect the degree of adjustment needed to compensate for non-ideal frequency response characteristics of the main speaker **280** as described in FIGS. 1A–1D. The crossover system **200** receives an input signal **210** and separates the input signal **210** into a high-frequency component **220** and a low-frequency component **230**. This high-pass signal **220** is sent to a main speaker amplifier **240**, which amplifies the pre-adjusted high-pass signal **220** to produce an amplified high-pass signal **260**. The amplified high-pass signal **260** is then sent to a main speaker **280** for the production of high-frequency sounds. The low-frequency component **230** is cascaded through a subwoofer amplifier **250** configured to amplify the low frequency component **230**, and the resulting amplified low-pass signal **270** is then sent to a subwoofer **290** configured to produce the low-frequency sounds. The

high-pass signal **220** produced by the crossover system **200** takes into account the non-ideal frequency response **180** (FIG. 1D) of the main speaker **280**. Hence, the blending of the subwoofer's sonic output with the main speaker's sonic output produces the desired combined sonic output.

Although the crossover system **200** is shown as a separate component, the crossover system **200** may be integrated with other components of the speaker system. For example, the crossover system **200** and subwoofer amplifier **250** may be integrated into a single unit or, alternatively, the crossover system **200** and main speaker amplifier **240** may be integrated into a single unit. Moreover, although the current embodiment shows both high- and low-frequency outputs from the crossover system **200**, it will be clear to one of ordinary skill in the art that the crossover system **200** may be such that only a high-frequency component may be produced by the crossover system. It will also be clear to one of ordinary skill in the art that the inventive nature of the crossover system **200** does not depend on the possible permutations by which the crossover system may be combined with other sound system components.

FIG. 3 shows a front panel, or user interface **205**, of a crossover system **200** (FIG. 2) in the sound system of FIG. 2. The user interface **205** allows the user to control many parameters associated with the sound reproduction system such as configuration parameters **215**, system parameters **225**, or main speaker characteristics **235**. The configuration parameters **215** typically include mode (e.g., augment or crossover), channel (e.g., stereo or mono), number of subwoofers, and main amplifier gain. System parameters **225** may include low frequency extension, low frequency level, and crossover frequency. Main speaker characteristics **235** may include type (e.g., sealed or reflex), low frequency limit, sensitivity, and damping factor. These parameters are adjusted using selection buttons **245** configured to select the parameter to be adjusted, and adjust buttons **255** configured to adjust those selected features. A display **285** on the user interface **205** apprises the user of the changing parameters. Once the system parameters are set using the selection buttons **245** and the adjust buttons **255**, the user may store the parameters using a store button **265**. Alternatively, once certain parameters have been stored, the user may recall the stored parameters using a recall button **275**.

Although several parameters and options are shown in the example user interface **205**, it will be clear to one of ordinary skill in the art that the user interface **205** may be more or less complex depending on the options available for such a system. For purposes of this discussion, the parameters of interest are configuration mode (specifically, crossover mode), the crossover frequency from the system parameters **225**, and the main speaker characteristics **235**. Upon selection of crossover mode (configuration parameter **215**) and crossover frequency (system parameter **225**), the user may enter main speaker characteristics **235** (e.g., type, low frequency limit, sensitivity, and damping factor) related to known characteristics of the main speaker **280** (FIG. 2). Responsive to the user's input of the main speaker characteristics **235**, the crossover system **200** adjusts the high-frequency response of the crossover system **200** (FIG. 2) so that the crossover **200** (FIG. 2) produces a high-pass signal **220** (FIG. 2) that, when cascaded through the main speaker amplifier **240** (FIG. 2) and the main speaker **280** (FIG. 2), produces a response that, when combined with the subwoofer response, produces an ideal combined response (i.e., a desirable blending of sound). Although the front panel (or user interface) is shown in the present embodiment as having configuration parameters, system parameters, and

main speaker characteristics, it will be clear to one of ordinary skill in the art that additional user options may be implemented through the user interface. These user options may include, but are not limited to, acoustics of the room, temperature, number of speakers, etc. Similarly, it will be clear to one of ordinary skill in the art that several options may be removed from the user interface in order to reduce the complexity of the system for the user. Although only certain options are shown in the user interface, it is not intended to limit the invention to only those options. On the contrary, the intent is to cover all alternatives, modifications, and equivalents included within the spirit and scope of the invention as defined by the appended claims.

Turning now to the details of the system for generating the high-frequency response according to the user inputs, FIG. 4A shows a compensation circuit **300a** that produces the high-pass signal **220** (FIG. 2). An input signal **210** is passed through a desired transfer function circuit **330a** configured to produce a desired system signal **340** having the characteristics of the desired crossover-speaker response **140** (FIG. 1D). The desired system signal **340**, therefore, possesses characteristics of the desired response which, when combined with the low-frequency response, produces the desired combined response. The desired system signal **340** having the desired response is then passed through an inverse transfer function circuit **310** configured to produce the high-pass signal **220**. The inverse transfer function circuit **310** comprises a negative-feedback operational amplifier **350** having an equivalent circuit **370a** in the feedback loop. The equivalent circuit **370a** is configured to mimic the main speaker **280** (FIG. 2) and produce a response equivalent to the actual speaker response **180** (FIG. 1D). Hence, when a signal passes through the equivalent circuit **370a**, that response will be as if the signal had passed through the main speaker **280** (FIG. 2). Thus, since the operational amplifier **350** is configured as a negative feedback amplifier, the resulting desired high-pass signal **220** will have frequency response characteristics that anticipate the actual speaker response **180** (FIG. 1D). Therefore, the high-pass signal **220**, when channeled through the main speaker **280** (FIG. 2), will produce a sonic output having the high-frequency response which, in turn, will produce the desired blending of sound.

To elaborate on the configuration of the compensation system **300a**, the inverse transfer function circuit **310** comprises an operational amplifier **350** configured to receive the desired system signal **340** at the positive input node **390** of the operational amplifier **350**. The equivalent circuit **370a** (having an equivalent frequency response as that of the main speaker **280** (FIG. 2)) bridges the output node **360** of the operational amplifier **350** with the negative input node **380** of the operational amplifier **350**, thus, comprising the feedback loop.

The compensation circuit **300a** of this invention can be best demonstrated by using a specific example. FIGS. 4B, 5A, 5B, 6A, 6B, and 6C provide the specific example illustrating the construction and operation of the compensation circuit **300a** illustrated in FIG. 4A. This example is not provided to limit the invention to the specific details but, rather, to more clearly illustrate the operation of certain aspects of the invention.

The system of FIG. 4A shows two components of the compensation circuit **300a**: (1) a desired transfer function circuit **330a**, and (2) an equivalent circuit **370a**. The equivalent circuit **370a** may be characterized by its characteristic frequency (also known as the  $-3$  dB point or the cutoff frequency), the damping factors (or Q-factors), and external factors such as the type of woofer enclosure (e.g., sealed or

reflex type). Although other factors may be used to characterize the system, the following example uses the characteristic frequency (F) and the damping factor (Q) associated with a sealed-woofer type main-speaker system.

FIG. 4B is a specific example of the compensation circuit 300a of FIG. 4A. Once the desired transfer function and the main speaker characteristics are known, these variables are used to create the compensation circuit 300a (FIG. 4A) configured to pre-adjust the high-pass input. In this specific example, the user sets the crossover frequency to 80 Hz, hence, making the high-pass characteristic frequency 80 Hz. Furthermore, the desired transfer function 330a (FIG. 4A) of the crossover-speaker combination is a 4<sup>th</sup>-order high-pass filter 330b with a desired characteristic frequency of 80 Hz and a Q-factor of 0.5. Also, if the main speaker uses a sealed woofer type main speaker system with a characteristic frequency of 50 Hz and a Q-factor of 0.7, a 2<sup>nd</sup>-order high-pass filter 370b with a characteristic frequency of 50 Hz and a Q-factor of 0.7 is used as the equivalent circuit 370a (FIG. 4A). Upon configuring the frequency of the 4<sup>th</sup>-order high-pass desired transfer function 330a (FIG. 4A) to filter 330b and the equivalent circuit 370a (FIG. 4A) to the 2<sup>nd</sup>-order high-pass filter 370b in response to the user inputs, the system is ready to produce the desired high-pass signal 220 from the input signal 320. The input signal 320 is passed through the 4<sup>th</sup>-order high-pass filter 330b, which produces the desired system signal 340 of the crossover-speaker combination. The desired system signal 340, when passed through the operational amplifier 350, having a 2<sup>nd</sup>-order high-pass filter 370b in the negative feedback loop, is effectively multiplied by the inverse function of the main speaker. The signal produced by multiplying the inverse of the main speaker to the desired system signal 340 is the desired high-frequency signal 220 that is eventually supplied to the main speaker amplifier 240 (FIG. 2) and, subsequently, to the main speaker 280 (FIG. 2). Although this specific example uses a specific 4<sup>th</sup>-order high-pass filter 330b to demonstrate the desired transfer function circuit 330a and a specific 2<sup>nd</sup>-order high-pass filter 370b to demonstrate the equivalent circuit 370a, it will be clear to one of ordinary skill in the art that these two circuits may be substituted with different types of circuits depending on the different speaker and crossover system responses.

Given the example circuit of FIG. 4B, FIGS. 5A and 5B illustrate a possible circuit for realizing the specific 4<sup>th</sup>-order high-pass filter 330b and the specific 2<sup>nd</sup>-order high-pass filter 370b.

FIG. 5A shows the 4<sup>th</sup>-order high-pass filter 330b of FIG. 4B. The 4<sup>th</sup>-order high-pass filter 330b comprises four resistor-capacitor (RC) circuits 450, 460, 470, 480 and two operational amplifiers 415, 425 that are configured as two serially-cascaded 2<sup>nd</sup>-order high-pass filters 410, 420. Both the 2<sup>nd</sup>-order high-pass filters 410, 420 comprise two serially connected RC circuits 450, 460, 470, 480 that are responsible for producing the high-pass characteristics of the desired system signal 340.

FIG. 5B shows the 2<sup>nd</sup>-order high-pass filter 370b of FIG. 4B. The example 2<sup>nd</sup>-order high-pass filter 370b comprises two RC circuits 430, 440 serially connected to the input of the operational amplifier 445 to produce the desired 2<sup>nd</sup>-order characteristics. If identical capacitors 433, 443 are used in each of the RC circuits 430, 440, and the capacitor value and resistor values are C<sub>1</sub>, R<sub>1</sub>, and R<sub>2</sub>, respectively,

then the characteristic frequency, F, and the Q-factor, Q, are given by Eq. 1 and Eq. 2, respectively:

$$F = \frac{1}{2\pi C_1 \sqrt{R_1 R_2}} \quad [\text{Eq. 1}]$$

$$Q = \frac{\sqrt{\frac{R_2}{R_1}}}{2} \quad [\text{Eq. 2}]$$

Thus, determining the values of R<sub>1</sub> (436 of FIG. 5B) and R<sub>2</sub> (446 of FIG. 5B) in terms of F and Q gives:

$$R_1 = \frac{1}{4\pi C_1 F Q} \quad [\text{Eq. 3}]$$

$$R_2 = \frac{Q}{\pi F C_1} \quad [\text{Eq. 4}]$$

A convenient way to achieve adjustable values of R<sub>1</sub> (436 of FIG. 5B) and R<sub>2</sub> (446 of FIG. 5B) is to realize them with voltage controlled equivalent resistances. This is shown in FIGS. 6A, 6B, and 6C.

FIGS. 6A and 6B show the resistors R<sub>1</sub> (436, FIGS. 4B and 5A) and R<sub>2</sub> (446, FIGS. 4B and 5B) as voltage-controlled equivalent resistances, each implemented with two operational transconductance amplifiers 520a, 540a, 520b, 540b. Details on the operation of transconductance amplifiers are well known and understood by persons skilled in the art, and need not be described herein. Given the circuit configurations of FIGS. 6A and 6B, the resistances R<sub>1</sub> and R<sub>2</sub> are represented by:

$$R_1 = \frac{2R_4 R_5}{gm R_3 V_1} \quad [\text{Eq. 5}]$$

$$R_2 = \frac{2R_4 R_6}{gm R_3 V_2} \quad [\text{Eq. 6}]$$

where V<sub>1</sub> and V<sub>2</sub> are the control voltages and gm is the transconductance per current through the resistors R<sub>5</sub> (590 of FIG. 6A) and R<sub>6</sub> (595 of FIG. 6B). Thus, the required voltages V<sub>1</sub> and V<sub>2</sub>, in terms of F and Q, are:

$$V_1 = \frac{8R_4 R_5 \pi C_1 F Q}{gm R_3} \quad [\text{Eq. 7}]$$

$$V_2 = \frac{2R_4 R_6 \pi C_1 F}{gm R_3 Q} \quad [\text{Eq. 8}]$$

FIG. 6C shows a microcontroller 505 that may be used in conjunction with the equivalent resistance circuits of FIGS. 6A and 6B. In practice, it is convenient to use a microcontroller 505 to perform the calculations so that user-adjustable controls for F and Q can supply voltages to the microcontroller 505, and the microcontroller 505 will supply outputs V<sub>1</sub> 510 and V<sub>2</sub> 515 according to Eqs. 7 and 8, respectively. Since the structure and operation of microcontrollers are well known in the art, these devices will not be discussed further. It is sufficient to say that careful adjustment of voltages V<sub>1</sub> (510 of FIGS. 6A and 6C) and V<sub>2</sub> (515

of FIGS. 6B and 6C) produces the desired resistances  $R_1$  (436 of FIGS. 5B and 6A) and  $R_2$  (446 of FIGS. 5B and 6B), which, in turn, are used to construct the 2<sup>nd</sup> order high-pass filter circuit 370b (FIGS. 4B and 5B), which is the inverse transfer function circuit 310 (FIG. 4A) used to produce the pre-adjusted high-frequency signal 220.

FIG. 7A shows the operation of the invention described above. In step 610, the user inputs user-adjustable settings into the crossover system. The system receives, in step 620, an input signal. This input signal is then used to produce, in step 630, a low-frequency component of the input signal, and contemporaneously, in step 640, a desired high-frequency component of the input signal. Although the present embodiment of the invention is configured to produce both a low-frequency component (step 630) and a desired high-frequency component (step 640), the crossover system may be configured to produce only the high-frequency component.

FIG. 7B shows the process of producing the desired high-frequency component 640 in more detail. Once the user-adjustable settings have been entered 610 (FIG. 7A) and the signal has been received 620 (FIG. 7A), the crossover, in step 651 determines the undesired sonic output characteristics of the main speaker from the user adjustable settings and, in step 652, compensates for the undesired sonic output characteristics by producing the desired frequency response characteristics which compensates for the undesired characteristics. Thus, the sound that is eventually produced from the main speaker will better complement the sound produced from the subwoofer.

FIG. 7C shows, in greater detail, the method of compensating for the undesired sonic output 652 (FIG. 7B). The crossover generates, in step 655, a desired system response that is reflective of the desired crossover and main speaker combination (i.e., the desired combined system response) from the user adjustable settings. In addition to the desired combined system response, the crossover generates, in step 656, an equivalent speaker response, which is reflective of the main speaker response, from the user adjustable settings. The equivalent speaker response is then deconvolved, in step 657, from the desired combined system response to produce the compensation circuit, which compensates for the undesired main speaker characteristics. The compensation circuit produces the desired high-frequency component from the input signal.

Although an exemplary embodiment of the present invention has been shown and described, it will be apparent to those of ordinary skill in the art that a number of changes, modifications, or alterations to the invention as described may be made, none of which depart from the spirit of the present invention. For example, the crossover system and the amplifiers may be integrated into a signal unit, the order of the filters (2<sup>nd</sup>- or 4<sup>th</sup>-order) do may be adjusted depending on the response of the actual system components, the low-frequency response may be removed from the crossover output, the method steps may be rearranged, etc. All such changes, modifications, and alterations should therefore be seen as within the scope of the present invention.

I claim:

1. An apparatus for adjusting the frequency response of a speaker system, the apparatus comprising: a user interface configured to receive user-adjustable variables indicative of main speaker low frequency characteristics; and

a compensation circuit configured to produce a desired high-pass signal from an input, the compensation circuit comprising:

a desired transfer function circuit having frequency response characteristics analogous to a desired crossover-main speaker combination;

an equivalent circuit having frequency response characteristics analogous to a main speaker; and  
a deconvolution circuit configured to deconvolve the main speaker characteristics from the desired crossover-main speaker combination characteristics.

2. The apparatus of claim 1, wherein the user-adjustable variable comprises at least one variable selected from the group consisting of:

a main speaker low frequency cutoff frequency;  
a main speaker low frequency damping factor;  
a speaker sensitivity factor;  
a speaker enclosure type; and  
a gain factor.

3. A crossover system for adjusting the frequency response of a speaker system, the crossover system comprising:

a user interface configured to directly receive user-adjustable variables from a user, the user-adjustable variables being indicative of main speaker low frequency characteristics, wherein the user-adjustable variables comprise at least one variable selected from the group consisting of: a main speaker low frequency cutoff frequency, a main speaker low frequency damping factor, a speaker sensitivity factor, and speaker enclosure type; and

a compensation circuit configured to produce a desired high-pass signal from an input signal in response to the user-adjustable variables.

4. A crossover system for adjusting the frequency response of a speaker system, the crossover system comprising:

a user interface configured to directly receive user-adjustable variables from a user, the user-adjustable variables being indicative of main speaker low frequency characteristics; and

a compensation circuit configured to produce a desired high-pass signal from an input signal in response to the user-adjustable variables, wherein the compensation circuit further comprises:

a desired transfer function circuit having frequency response characteristics analogous to a desired crossover-main speaker combination;  
an equivalent circuit having frequency response characteristics analogous to a main speaker; and  
a deconvolution circuit configured to deconvolve the main speaker characteristics from the desired crossover-main speaker combination characteristics.

5. A method for adjusting the frequency response of a speaker system, the method comprising the steps of:

directly receiving user-adjustable settings from a user, the user-adjustable settings being indicative of main speaker low frequency characteristics; and

producing desired frequency response characteristics in response to the user adjustable settings, wherein the producing step further comprises the steps of:

generating a combined system response from the user adjustable settings, the combined system response having frequency response characteristics of a desired combined system;

generating an equivalent speaker response from the user adjustable settings, the equivalent speaker response having frequency response characteristics of the main speaker; and

deconvolving the equivalent speaker response from the combined speaker response to produce a compensated response.