

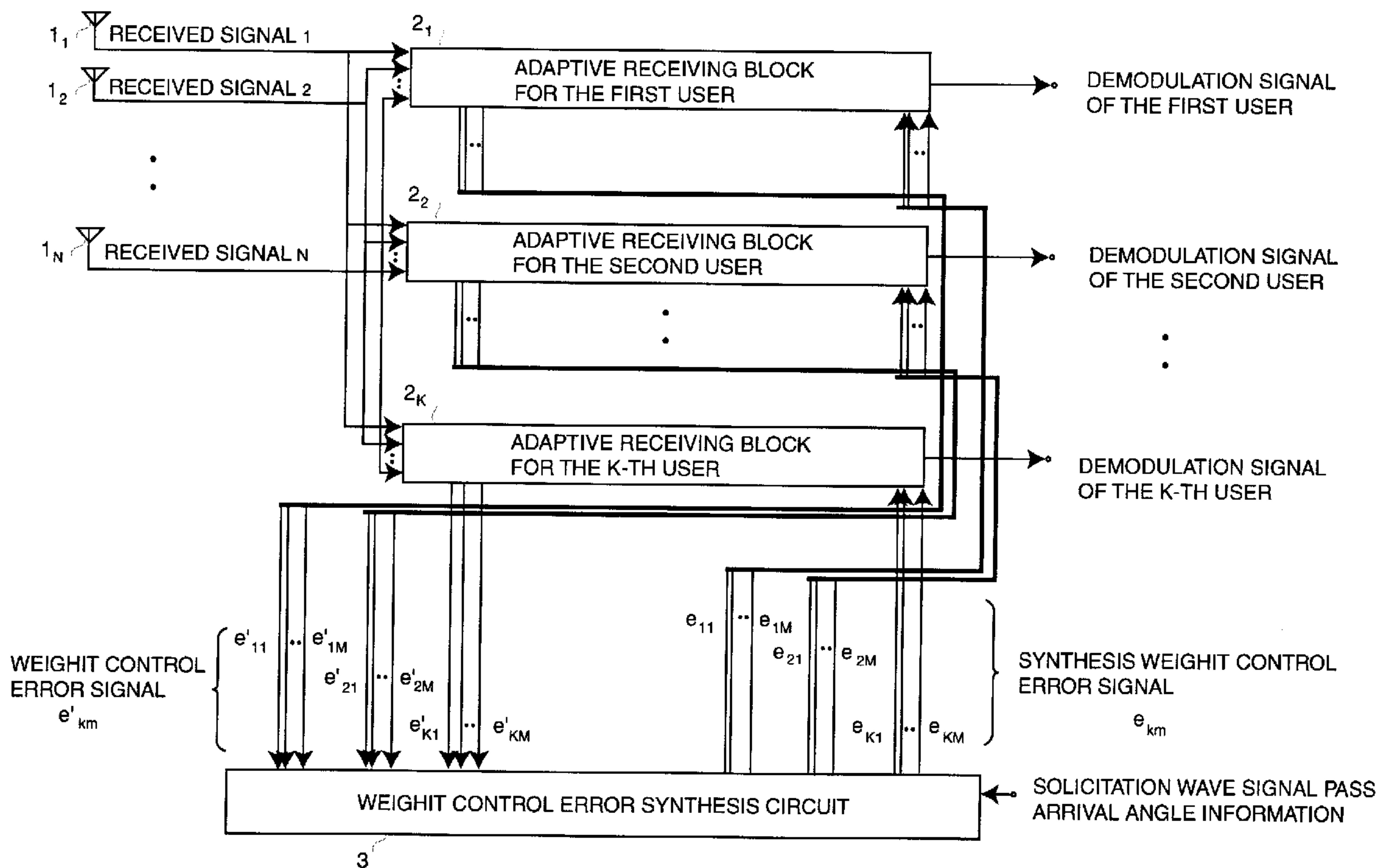

(22) Date de dépôt/Filing Date: 1999/02/12
 (41) Mise à la disp. pub./Open to Public Insp.: 1999/08/13
 (45) Date de délivrance/Issue Date: 2002/01/22
 (30) Priorité/Priority: 1998/02/13 (10-046334) JP

(51) Cl.Int.⁶/Int.Cl.⁶ H01Q 19/00, H04B 7/015
 (72) Inventeurs/Inventors:
 USHIROKAWA, Akihisa, JP;
 YOSHIDA, Shousei, JP;
 MARUTA, Yasushi, JP
 (73) Propriétaire/Owner:
 NEC CORPORATION, JP
 (74) Agent: SMART & BIGGAR

(54) Titre : DISPOSITIF DE RECEPTION ADAPTATIF POUR ANTENNES
 (54) Title: ADAPTIVE RECEIVING DEVICE FOR ANTENNAS



(57) Abrégé/Abstract:

The adaptive receiving block 2k for the k-user generates a receiving signal by the k-th user the m-th pass inherent antenna directivity pattern respectively, obtains the k-th user demodulation signal by demodulating and adding for each pass simultaneously and outputs weight control error signal e'_{kl}~e'_{km} for the purpose of forming directivity pattern for each pass. The weight control error synthesis circuit 3 optionally synthesizes weight control error signal e'_{kl}~e'_{km} and outputs synthesis weight

(57) **Abrégé(suite)/Abstract(continued):**

control error signal $e_{kl} \sim e_{kM}$. Synthesizing weight control error signals with respect to passes whose arrival directions of multi-pass of each user are close, performing a control without synthesizing weight control errors with respect to passes whose arrival directions are apart, increasing the information available for adaptive control and enhancing an adaptive control characteristic and an interference suppression ability.

ABSTRACT

The adaptive receiving block 2k for the k-user generates a receiving signal by the k-th user the m-th pass inherent antenna directivity pattern respectively, obtains the k-th user demodulation signal by demodulating and adding for each pass simultaneously and outputs weight control error signal $e'_{k1} \sim e'_{km}$ for the purpose of forming directivity pattern for each pass. The weight control error synthesis circuit 3 optionally synthesizes weight control error signal $e'_{k1} \sim e'_{km}$ and outputs synthesis weight control error signal $e_{k1} \sim e_{km}$. Synthesizing weight control error signals with respect to passes whose arrival directions of multi-pass of each user are close, performing a control without synthesizing weight control errors with respect to passes whose arrival directions are apart, increasing the information available for adaptive control and enhancing an adaptive control characteristic and an interference suppression ability.

ADAPTIVE RECEIVING DEVICE FOR ANTENNAS**BACKGROUND OF THE INVENTION**

The present invention relates to an adaptive receiving
5 device removing interference from other users by an antenna
directivity control, more particularly to an adaptive
receiving device for a CDMA (Code Division Multiple Assess).

In such a cellular mobile communication system, interference
from other users and interference by delay waves are the
10 dominant factors which determine a receiving quality. Methods
for removing these interference by employing adaptive antennas
are considered. On the other hands, a CDMA method which can
be expected for capacity acceptable for a large subscribership
is noted as a wireless transmission method. A method utilizing
15 a spread process gain is proposed as a receiving device
employing an adaptive antenna which is suitable for a CDMA
method.

Conventionally, for this type of an adaptive receiving device
for a CDMA, as indicated, for example, in Oh, Kohno and Imai:
20 "An TDL adaptive array antenna using spread process gain for
spectrum spread multi-dimension connections", Communication
Engineering Theory, Vol.J75-BII No. 11, pp. 815-825, 1992, and
in Tanaka, Miki and Sawahashi: "Characteristic of decision
feedback-type coherent adaptive diversity in DS-CDMA",
25 Communication Engineering Technical Report, RCS96-102,

1996-11, the effect of SINR improvement due to process gain in an adaptive control is obtained by utilizing weight control error signal taken after de-spreading upon an antenna weight controlling.

5 Fig. 7 is a block diagram showing an example of conventional CDMA adaptive receiving devices, and Fig. 8 is a block diagram showing an adaptive receiving sub-block 27_m for the m-th pass in an adaptive receiving device for a CDMA of Fig. 7. Here, an adaptive receiving device for a CDMA is represented in the
10 case where the number of receiving antennas is N (N is an integer more than 1), the number of users is K (K is an integer more than 1), and the number of multi-paths is M (M is an integer more than 1).

Each of receiving antenna 1₁~1_N made of N pieces receives
15 solicitation wave signals and a plurality of interference wave signals which are code-multiplexed. Receiving antenna 1₁~1_N are arranged closely so that each receiving signal has the correlation with each other. The first adder 5 adds outputs of adaptive receiving sub-blocks 27₁~27_M for the first~the
20 M-th pass, and outputs the k-th user demodulation signal. The decision circuit 6 performs hard decision for the first adder 5, outputs the k-th user decision symbol.

The adaptive receiving sub-block for the m-th pass is composed of the weighted synthesis circuit 7, the first delay
25 circuit 10, the de-spreading circuit 11, the demodulation

circuit 12, the third complex multiplier 15, the error detection circuit 16, the fourth complex multiplier 17, the second delay circuit 18, the third delay circuit 19 and the antenna weight control circuit 20.

5 The adaptive receiving sub-block 27m for the m-th pass inputs antenna receiving signal 1~ antenna signal N and the k-th user decision symbol which is an output outputted from the decision circuit 6.

The weighted synthesis circuit 7 is composed of the first
10 complex multiplier $8_1 \sim 8_N$ and the second adder 9. A signal received by the m-th pass inherent antenna directivity pattern is generated by multiplying antenna receiving signal 1 ~ antenna receiving signal N by antenna weight $W_{m1} \sim$ antenna W_{mN} and by adding them.

15 The first delay circuit 10 delays an output outputted from the weighted synthesis circuit 7 on the basis of pass delay of an separately required solicitation wave signal corresponding to multi-path. The de-spreading circuit 11 computes the correlation between an output of the weighted
20 synthesis circuit 7 and a spread code C_k of the k-user. The modulation circuit 12 is composed of the transmission path estimate circuit 13 and the second complex multiplier 14. An output which is multiplied the de-spreading circuit 11 by a complex conjugate of transmission estimate output becomes an
25 output of adaptive receiving sub-block 27m for the m-th pass.

The third complex multiplier 15 multiplies the k user decision symbol by a transmission path estimate output. The error detection circuit 16 computes the difference between an output of the third complex multiplier 15 and an output of the de-spreading circuit 11, and detects detection errors. The fourth complex multiplier 17 multiplies a decision error by the k-user spread code C_k , and generates a weight control error signal. The delay circuit 18 delays weight control error signals on the basis of pass delay of the foregoing separately required solicitation signal so as to cancel out the effect of the first delay circuit 10.

The third delay circuit 19 delays antenna receiving signal 1 ~ antenna receiving signal N in accordance with the processing time of the weighted synthesis 7, the de-spreading circuit 11, the demodulation circuit 12, the error detection circuit 16 and the like. The antenna weight control circuit 20 computes antenna weight $W_{m1} \sim W_{mN}$ from a weight control error signal which is an output of the second delay circuit 18 and an output of the delay circuit 19.

By assuming a spread code C_k as a complex code composed of a code of C_{k1} and a code of C_{kQ} which are in an orthogonal relationship of the two (2) affiliations, the de-spreading circuit 11 can be realized by one-piece of complex multiplier and an averaging circuit over a symbol interval. Moreover, the de-spreading circuit 11 can be also realized by a transversal

filter component in the case of assuming C_k as a tap weight.

In receiving signals from receiving antenna $l_1 \sim l_N$ of N pieces, a solicitation wave signal component, an interference wave signal component and thermal noise are included. Moreover, multi-path component exists in a solicitation wave signal component and in an interference wave signal component respectively. Conventionally, those signal components arrive from different directions.

A conventional adaptive receiving device for a CDMA shown in Fig. 7 and 8, prepares adaptive receiving sub-block $27_1 \sim 27_M$ for the first~the M -th pass independently with respect to multi-path components and performs weighted synthesis of a receiving signal in each weighted synthesis circuit 7 so as to make solicitation wave signal-to-interference wave signal power rate (SIR) of signal components of each pass to be the maximum value. As a result, as for antenna gain with respect to the arrival directions (directivity pattern) of adaptive receiving sub-block $27_1 \sim 27_M$ for the first~the M -th pass, it is formed so that it becomes larger with respect to the respective arrival directions of pass signal components and becomes smaller with respect to other delay wave signal components and interference wave signal components.

In order to improve the deterioration of adaptive control characteristic of a conventional adaptive receiving device for a CDMA shown in Fig. 7 and 8 in the case where the number of

passes are large, the authors previously proposed an adaptive receiving device for a CDMA adding weight control error of all passes for each user(Japanese Patent Application No. H9-210336). This adaptive receiving device for a CDMA prepares
5 a weighted synthesis circuit with respect to each user, and performs weighted synthesis of antenna weight and antenna receiving signal so as to make synthesis weight control error signal adding weight control error signal of all passes for each user to be the minimum value. As a result, one directivity
10 pattern for each user is formed, antenna gain becomes larger with respect to the arrival directions of signal components of each pass, and it becomes smaller with respect to the interference components. Since this method adds weight control error signals of all passes for each user, information of
15 adaptive control becomes increasing, and its adaptive control characteristic is excellent even in the case where the number of passes is large.

Since a conventional adaptive receiving device for a CDMA shown in Fig. 7 and 8 uses error signal independently in a unit
20 of each pass and forms independent directivity pattern, in the case of error signal of pass of smaller power, the reliability is lowered by transmission path estimate error. Therefore, in the case where the number of passes is large, the adaptive control characteristic is deteriorated, particularly, it
25 becomes the problem that the directivity pattern of pass when

it is smaller power is difficult to be formed.

As means for solving the problem, an adaptive receiving device for a CDMA adding weight control error of all passes for the above described each user is proposed, but when
5 multi-path component of solicitation wave signal arrival angle difference is incorporated simultaneously, since the width of beam is broadened and excessive interference is also incorporated, interference suppression ability is deteriorated in the case where the arrival angle difference
10 of multi-path is large.

Moreover, since a conventional adaptive receiving device for a CDMA forms different directivity pattern for each user, it is the problem that it is difficult to perform multi-user receiving which receives a plurality of signals of users as
15 a unit.

SUMMARY OF THE INVENTION

An objective of the present invention is to provide an adaptive receiving device whose adaptive control characteristic and interference suppressive ability are
20 excellent under circumstances where a large number of passes arrive from various angles.

The other objective of the present invention is to provide an adaptive receiving device which can easily realize a multi-user receiving.

25 The adaptive receiving device of the present invention forms

a pattern simultaneously incorporating passes of given combinations from all multi-paths of all users as a directivity pattern receiving each pass of each user.

More particularly, the adaptive receiving device of the present invention comprises an adaptive receiving block for the first ~ the K-th user ($2_1 \sim 2_K$ of Fig. 1), an adaptive receiving sub-block for the first ~ the M-th pass for each user ($4_1 \sim 4_M$ of Fig. 2), and one weight control error synthesis means (3 of Fig. 1).

In the present invention, weight control error signal is synthesized with respect to passes whose arrival directions are close to each other, and performs a control without weight control error difference with respect to passes whose arrival directions are apart. Through these performances, the volume of information available for adaptive control can be increased, and excellent adaptive control characteristic and interference suppression ability are obtained. Moreover, by performing a control of synthesizing weight control error signals of a plurality of multi-user, a multi-user receiving can be easily realized.

In accordance with the present invention, there is provided an adaptive receiving device comprising: receiving antennas of N-pieces (N is an integer of more than 1) receiving signals multiplexed by a plurality of signals of users; adaptive receiving block of K-pieces corresponding to K-pieces users (K is an integer of more than 1) forming directivity pattern having a gain for given directions with respect to receiving signals of said receiving antennas, receiving a solicitation wave signal composed of a plurality of passes and suppressing interference wave signals; and weight control error synthesis means synthesizing a plurality of weight control

74790-29

8a

errors by combinations of given users and passes and generating synthesis weight control error signals, wherein said adaptive receiving block forms said directivity pattern based on said synthesis weight control error signal.

5

BRIEF DESCRIPTION OF THE DRAWINGS

This and other objects, features and advantages of the present invention will become more apparent upon a reading of the following detailed description and drawings, in which: Fig. 1 is a block diagram showing the embodiment of an adaptive

receiving device according to the present invention,

Fig. 2 is a block diagram showing the k-th user adaptive receiving block of an adaptive receiving device according to the present invention,

5 Fig. 3 is a block diagram showing the m-th path adaptive receiving sub-block of an adaptive receiving device for a CDMA according to the present invention,

Fig. 4 is a block diagram showing a general form of weight control error synthesis circuit of an adaptive receiving
10 device for a CDMA according to the present invention.

Fig. 5 is a block diagram showing the other example of weight control error synthesis circuit of an adaptive receiving device for a CDMA according to the present invention,

Fig. 6 is a block diagram showing the other example of weight
15 control error synthesis circuit of an adaptive receiving device for a CDMA according to the present invention,

Fig. 7 is a block diagram showing an example of a conventional adaptive receiving device for a CDMA, and

Fig. 8 is a block diagram showing the m-th path adaptive
20 receiving sub-block of a conventional adaptive receiving device for a CDMA.

DESCRIPTION OF THE EMBODIMENTS

Fig. 1 is a block showing the embodiment of an adaptive receiving device according to the present invention. In Fig.
25 1, that signals multiplexed are code division multiplex

signals, and an adaptive receiving device (adaptive receiving device for a CDMA) which is provided for N (N is an integer of more than 1) of the number of receiving antenna, K (K is an integer of more than 1) of the number of users and M (M is a integer of more than 1) of the number of multi-paths, are shown.

Referring to Fig. 1, an adaptive receiving device is composed of receiving antenna $1_1 \sim 1_N$, adaptive receiving block $2_1 \sim 2_K$ for the first \sim the K -th user and the weight control error synthesis circuit 3. N pieces of receiving antenna $1_1 \sim 1_N$ receive solicitation wave signals and a plurality of interference wave signals which are code-multiplexed respectively. Receiving antenna $1_1 \sim 1_N$ are arranged being nearby each other so that each receiving signal has the correlation relation with each other.

Fig. 2 is a block diagram showing adaptive receiving block 2_k for the k -th user. Each of k pieces of adaptive receiving block $2_1 \sim 2_K$ for the first \sim the K -th user as shown in Fig. 2, is composed of adaptive receiving sub-block $4_1 \sim 4_M$ for the first \sim the M -th pass, the first adder 5 and the decision circuit 6.

The first adder 5 of adaptive receiving block 2_k for the k -th user adds outputs of adaptive receiving sub-block $4_1 \sim 4_M$, and outputs the k -th user demodulation signal. The decision circuit 6 performs harden decision for an output of the first adder 5, and outputs the k -th user decision symbol.

Fig. 3 is a block diagram showing adaptive receiving

sub-block 4_m for the m -th pass of adaptive receiving block 2_k for the k -th user according to the present invention. Each of adaptive receiving sub-block $4_1 \sim 4_M$ for the first \sim the M -th pass as shown in Fig. 3, is composed of the weighted synthesis circuit 7, the first delay circuit 10, the de-spreading circuit 11, the demodulation circuit 12, the third complex multiplier 15, the error detection circuit 16, the fourth complex multiplier 17, the second delay circuit 18, the third delay circuit 19 and the antenna weight control circuit 20. Adaptive receiving sub-block 4_m for the m -th pass for the sake of the k -th user inputs antenna receiving signal 1 \sim antenna receiving signal N , the k -th user decision symbol and synthesis weight control error signal $e_{k1} \sim e_{kM}$.

The weighted synthesis circuit 7 is composed of the first complex multiplier $8_1 \sim 8_N$ and the second adder 9, by multiplying antenna receiving signal 1 \sim antenna receiving signal N by antenna weight $W_{m1} \sim W_{mN}$ and by adding them, a signal received by the m -th pass inherent antenna directivity pattern is generated. The first delay circuit 10 based on pass delay of solicitation wave signal which separately required an output of the weighted synthesis circuit 7, performs delaying in accordance with multi-path.

The de-spreading circuit 11 performs the correlation calculation between an output of the first delay circuit 10 and a spread code C_k of the k -user. Assuming that a spread code

C_k is a complex code composed of a code C_{kI} and C_{kQ} which are in an orthogonal relationship of the two (2) affiliations, the de-spreading circuit 11 can be realized with one complex multiplier and the averaging circuit over a symbol interval.

5 Moreover, the de-spreading circuit 11 can be also realized with transversal filter composition making C_k a tap weight.

The demodulation circuit 12 is composed of the transmission estimate circuit 13 and the second complex multiplier 14, an output which is multiplied an output of the de-spreading circuit 11 by a complex conjugate of transmission path estimate output becomes an output of the adaptive receiving sub-block 10 4m for the m-th pass.

The third complex multiplier 15 multiplies the k-th user decision symbol and a transmission path estimate output 15 outputted from the transmission path estimate circuit 13 together. It should be noted that as a transmission path estimate output which is complex-multiplied by decision symbol in the complex multiplier 15, only component concerning with phase outputted from the transmission path estimate circuit 20 13 is multiplied, and as for an amplitude, an amplitude which is required by other separate means, for example, an amplitude which is obtained in a functional block searching for a level and a timing of multi-path of receiving signal can be also multiplied. The error detection circuit 16 computes a 25 difference between an output of the third complex multiplier

15 and an output of the de-spreading circuit 11, and detects decision errors.

The fourth complex multiplier 17 multiplies a decision error by a spread code C_k of the k-th user.

5 The second delay circuit 18 performs delaying on the basis of pass delay of the foregoing solicitation wave signal required separately so that the effect of the first delay circuit 10 is cancelled out by an output of the fourth complex multiplier 17, and outputs a weight control error signal. The third delay
10 circuit 19 delays antenna receiving signal 1 ~ antenna receiving signal N in accordance with the processing time of the weighted synthesis circuit 7, the de-spreading circuit 11, the demodulation circuit 12 and the like.

The antenna weight control circuit 20 inputs an output of
15 synthesis weight control error signal e_{km} and an output of the third delay circuit 19, and computes antenna weight $W_{m1} \sim W_{mN}$. Here, antenna weight $W_{m1} \sim W_{mN}$ are adaptively controlled by the MMSE standard so that the square-average value of e_{km} becomes the minimum value. In the case where LMS algorithm is employed
20 as an update algorithm for a small amount of calculation, antenna weight $W_{m1} \sim W_{mN}$ are expressed by,

$$W_m(i+1) = W_m(i) + \mu r(i - D_{dem}) e_{km}^* (i) \quad (1)$$

where $W_m(i)$ (column vector having factors of N pieces) is antenna weight of the i-chip-th in the m-th pass, $r(i)$ (column
25 vector having factors of N pieces) is antenna receiving signal,

μ is step size, D_{dem} is a delay time given by the third delay circuit 19. Besides these, $*$ represents a complex conjugate.

Expression (1) shows that the updating of antenna weight $W_{m1} \sim W_{mN}$ is performed in a chip period. Since the detection of decision error of each pass is performed by every symbol, by the product of integrating $r(i - D_{dem})$ and $e_{km}^*(i)$ by one-symbol fraction, an update can be reduced by every symbol. Moreover, a step size μ which is a coefficient of varying amount when antenna weight $W_{m1} \sim W_{mN}$ are updated is characterized in that in the case where its value is large, although the convergence to antenna weight $W_{m1} \sim W_{mN}$ for the purpose of the optimal directivity pattern formation is accelerated, but the accuracy and the stability of the adaptation are deteriorated, and on the other hand, in the case where its value is small, although the accuracy and the stability of the adaptation are good, but the convergence is delayed. That sufficient convergence rate, the accuracy and the stability of the adaptation are obtained by varying step size adaptively is also included in the present invention. Moreover, in the convergence process, the known symbol previously sent from the transmitting side also can be used in stead of the decision symbol.

Fig. 4 is a block diagram showing a general form of the weight control error synthesis circuit 3. Referring to Fig. 4, the weight control error synthesis circuit 3 is composed of the first switching matrix 21 and the third adder $22_{11} \sim 22_{KM}$. The

first switching matrix 21 receives weight control error $e'_{11} \sim e'_{KM}$ of each pass of all users and solicitation wave signal pass arrival angle information of all users separately required as inputs, and outputs given combinations of weight control error $e'_{11} \sim e'_{KM}$ on the basis of this solicitation wave signal pass arrival angle information. The third adder $22_{11} \sim 22_{KM}$ adds outputs of the first switching matrix 21 and generates synthesis weight control error $e_{11} \sim e_{KM}$.

Fig. 4 shows a general form of the weight control error synthesis circuit 3, synthesis of weight control error signal can be synthesized by given combinations selected from all passes of all users. In the present invention, methods of synthesizing weight control error are not limited, naturally, it is necessary to determine the manner of synthesis on the basis of a certain standard.

Fig. 5 is a block diagram showing another example of the weight control error synthesis circuit 3. The weight control error synthesis circuit 3 of Fig. 5 is composed of the second switching matrix $23_1 \sim 23_K$ and the third adder $22_{11} \sim 22_{KM}$. The second switching matrix $23_1 \sim 23_K$ outputs given combinations utilizing only weight control error of M pieces of each user. The third adder $22_{11} \sim 22_{KM}$ adds outputs of the second switching matrix $23_1 \sim 23_K$ and generates synthesis weight control error $e_{11} \sim e_{KM}$.

In the weight control error synthesis circuit 3 of Fig. 5,

by optionally synthesizing weight control error for each user independently, for example, close arrival waves in a unit can be received by one directivity pattern. The information of adaptive control is increased approximately by several-fold
5 of the number of passes synthesized, and the characteristics of the convergence and the follow-up are excellent.

Fig. 6 is a block diagram showing further the other example of the weight control error synthesis circuit 3. The weight control error synthesis circuit 3 of Fig. 6 is composed of the
10 fourth adder $24_1 \sim 24_K$, the third switching matrix 25 and the fifth adder $26_1 \sim 26_K$. The fourth adder $24_1 \sim 24_K$ adds weight control errors of M pieces for each user. The third switching matrix 25 outputs given combinations utilizing weight control errors of K pieces which are outputs of the fourth adder 24_1
15 $\sim 24_K$. The fifth adder $26_1 \sim 26_K$ adds outputs of the third switching matrix 25 and generates synthesis weight control error $e_{11} \sim e_{KM}$.

In the weight control error synthesis circuit 3 of Fig. 6, at first, for each user, after one synthesis weight control
20 error is made, since directivity pattern (multi-user-beam) which receives signals of a plurality of users in a unit can be formed by performing synthesis of weight control errors of a plurality of users in the third switching matrix 25, if the weight control error synthesis circuit 3 could be employed,
25 a multi-user receiving can be easily realized.

It should be noted that the weight control error synthesis circuit 3 can be considered in other compositions rather than in compositions shown in Fig. 5 and 6, but all is included in the weight control error synthesis circuit 3 of Fig. 4.

5 It is desirable that the processes of the present invention are performed digitally in a base band. For the sake of that, it is necessary to convert a receiving signal of each antenna from a wireless band frequency to a base band frequency and perform analogue/digital conversion of it. In Fig. 1 through
10 Fig. 8, those functions are omitted.

Moreover, in the embodiment of the present invention, a code length of a spread code C_k , that is to say, spread rate is not limited. The adaptive receiving device according to the present invention is also applicable to signals which are
15 multiplexed by other methods rather than by code division multiplex access (CDMA) method and whose spread rate is 1.

Furthermore, as for receiving antenna in the present invention, the number N , the manner of arrangement (circular arrangement, linear arrangement and the like) the interval of
20 arrangement ($1/2$ of carrier wave and the like) or directivity characteristic in a single equipment of antenna (omni-antenna, selector antenna and the like) is not limited, and can be executed in appropriate embodiments. Furthermore, K of the number of users which are received simultaneously and M of the
25 number of multi-paths of each user also can be set optionally.

According to the present invention, since information available for adaptive control is increased by synthesizing a weight control error signal with respect to passes whose arrival directions of multi-path of each user are close each other and performing a control without synthesizing weight control errors with respect to passes whose arrival directions are apart each other, adaptive control characteristic and interference suppression ability are excellent under circumstances where a large number of passes arrive from various angles.

Moreover, since the present invention performs a control synthesizing weight control error signals of a plurality of users, a multi-user receiving can be easily realized.

CLAIMS:

1 An adaptive receiving device comprising:

receiving antennas of N-pieces (N is an integer of more than
1) receiving signals multiplexed by a plurality of signals
5 of users;

adaptive receiving block of K-pieces corresponding to K-
pieces users (K is an integer of more than 1) forming
directivity pattern having a gain for given directions with
respect to receiving signals of said receiving antennas,
10 receiving a solicitation wave signal composed of a plurality
of passes and suppressing interference wave signals; and

weight control error synthesis means synthesizing a
plurality of weight control errors by combinations of given
users and passes and generating synthesis weight control error
15 signals,

wherein said adaptive receiving block forms said directivity
pattern based on said synthesis weight control error signal.

2 An adaptive receiving device of claim 1, each of said
adaptive receiving block of K-pieces comprising:

20 adaptive receiving sub-blocks of M-pieces receiving
received signals from said receiving antennas of N-pieces and
said synthesis weight control error signals as inputs, forming
a directivity pattern having a gain for given directions with
respect to a multi-path of M-pieces (M-is an integer of more
25 than 1), suppressing interference wave signals, receiving

solicitation wave signals and demodulating said solicitation wave signals;

adders adding demodulating signals of said adaptive receiving sub-blocks of M-pieces; and

5 decision means for hard deciding said output of said adders and outputting decision symbols.

3 An adaptive receiving device of claim 2, wherein said multiplexed signals are code division multiplex signals, and said each adaptive receiving sub-block receives receiving
10 signals from said receiving antennas of N-pieces, said decision symbols and said synthesis weight control error signals as inputs,

said each adaptive receiving sub-block of M-pieces comprising:

15 weighted synthesis means for forming directivity pattern of received signals from said receiving antennas of N-pieces;

delay means for delaying an output of said weighted synthesis means for each multi-path based on pass delay of solicitation wave signal;

20 de-spreading means for de-spreading an output of said delay means utilizing a spread code of said solicitation wave signal;

demodulation means for estimating a transmission path estimate of output of said de-spreading means;

multiplier for multiplying said decision symbol and complex
25 transmission path estimate value which is an output of said

demodulation means and canceling out a phase change made by carrier wave phase synchronization;

error detection means for taking each output of said de-spreading means from an output of said multiplier and detecting
5 determination errors;

multiplier for multiplying said determination error by a spread code of said solicitation wave signal and generating a weight control error signal;

delay means for delay-supplementing said weight control
10 error signal so as to cancel out an effect of said delay means;

delay means for assigning delays corresponding to processing time in said weighted synthesis means, said de-spreading means, said demodulation means and said weight control error synthesis means to receiving signals from said receiving
15 antennas of N-pieces; and

antenna weight control means for calculating antenna weight of N-pieces based on said delayed receiving signals of N-pieces and said synthesis weight control error signal and outputting said antenna weight signal to said weighted synthesis means.

4. An adaptive receiving device of claim 1, wherein said weight control error synthesis means has a switching matrix receiving weight control error signals of pieces of a number of multiplying K and M together which are outputs of said adaptive receiving sub-blocks and pass arrival angle information of
25 K-pieces users as inputs and outputting said synthesis weight

control error signals synthesized by given combinations of more than one said weight control error signal.

5 An adaptive receiving device of claim 1, wherein said weight control error synthesis means comprises a switching
5 matrix which is controlled so as to receive weight control error signals of pieces of a number of multiplying K and M together which are outputs of said adaptive receiving sub-blocks and pass arrival angle information of K-pieces users as inputs, synthesize all of said weight control error signals of each
10 pass of an identical user upon synthesizing said weight control error signal, output one synthesis weight control error signal per one user and form one directivity pattern per one user.

6 An adaptive receiving device of claim 1, wherein said weight control error synthesis means comprises a switching
15 matrix which is controlled so as to receive weight control error signals of pieces of a number of multiplying K and M together which are outputs of said adaptive receiving sub-blocks and pass arrival angle information of K-pieces users as inputs and synthesize only said weight control error signals of close
20 arrival direction passes of an identical user upon synthesizing said weight control error signals.

7 An adaptive receiving device of claim 1, wherein said weight control error synthesis means comprises a switching
matrix which is controlled so as to receive weight control error
25 synthesis signals of pieces of a number of multiplying K and

M together which are outputs of said adaptive receiving sub-blocks and pass arrival angle information of K-pieces users as inputs, synthesize all of said weight control error signals of each pass of an identical user upon synthesizing
5 said weight control error signals, and after synthesizing one weight control error signal per one user, further synthesize said weight control error signals of users of close arrival directions.

8 An adaptive receiving device of claim 1, wherein said
10 weight control error synthesis means comprises a switching matrix which is controlled so as to receive weight control error signals of pieces of a number of multiplying K and M together which are outputs of said adaptive receiving sub-blocks and pass arrival angle information of K-pieces users as inputs and
15 synthesize said weight control error signals of close arrival direction passes regardless of whether said close arrival direction passes are of any identical user or not.

9 An adaptive receiving device of claim 3, wherein said
20 weighted synthesis means receives receiving signals from said receiving antennas of N-pieces and antennas weight of N-pieces as inputs and comprise complex multipliers of N-pieces multiplying said receiving signals of N-pieces by said antennas weight of N-pieces respectively and an adder synthesizing each output of said complex multipliers of N-
25 pieces.

74790-29

- 24 -

10. An adaptive receiving device of claim 3, said demodulation means comprising:

transmission path estimate means for receiving an
5 output of said de-spreading means as an input and estimating an amplitude and a phase of a carrier wave;

complex conjugate operation means for requiring
complex conjugate of a complex transmission path estimate value
10 which is an output of said transmission path estimate means;
and multiplier for multiplying an output of said inverse spread means by an output of said complex conjugate operation means,
performing carrier wave phase synchronization and
simultaneously performing weighted operation for maximum rate
15 combination.

11. An adaptive receiving device of claim 2, in said adaptive receiving sub-block of said adaptive receiving device, wherein a known symbol is used instead of a decision symbol in
20 a convergence process.

12. An adaptive receiving device of claim 2, in said adaptive receiving sub-block of said adaptive receiving device, wherein when a decision symbol is multiplied by transmission
25 path estimate values of each pass, a decision symbol is multiplied by only components concerning with phase of estimate value, and as for an amplitude, a determination signal is multiplied by an amplitude required by a separate means.

30 13. An adaptive receiving device of claim 3, in said antenna

weight control means of said adaptive receiving device, wherein an adaptive control antenna weight is performed by least mean square error standard so that average power of a synthesis weight control error signal is the minimum value.

5 14 An adaptive receiving device of claim 3, in said antenna weight control means of said adaptive receiving device, wherein least mean square (LMS) algorithm is utilized upon performing an adaptive control of an antenna weight with least mean square error standard.

Grant & Egan
Ottawa, Canada
Patent Agents

FIG.1

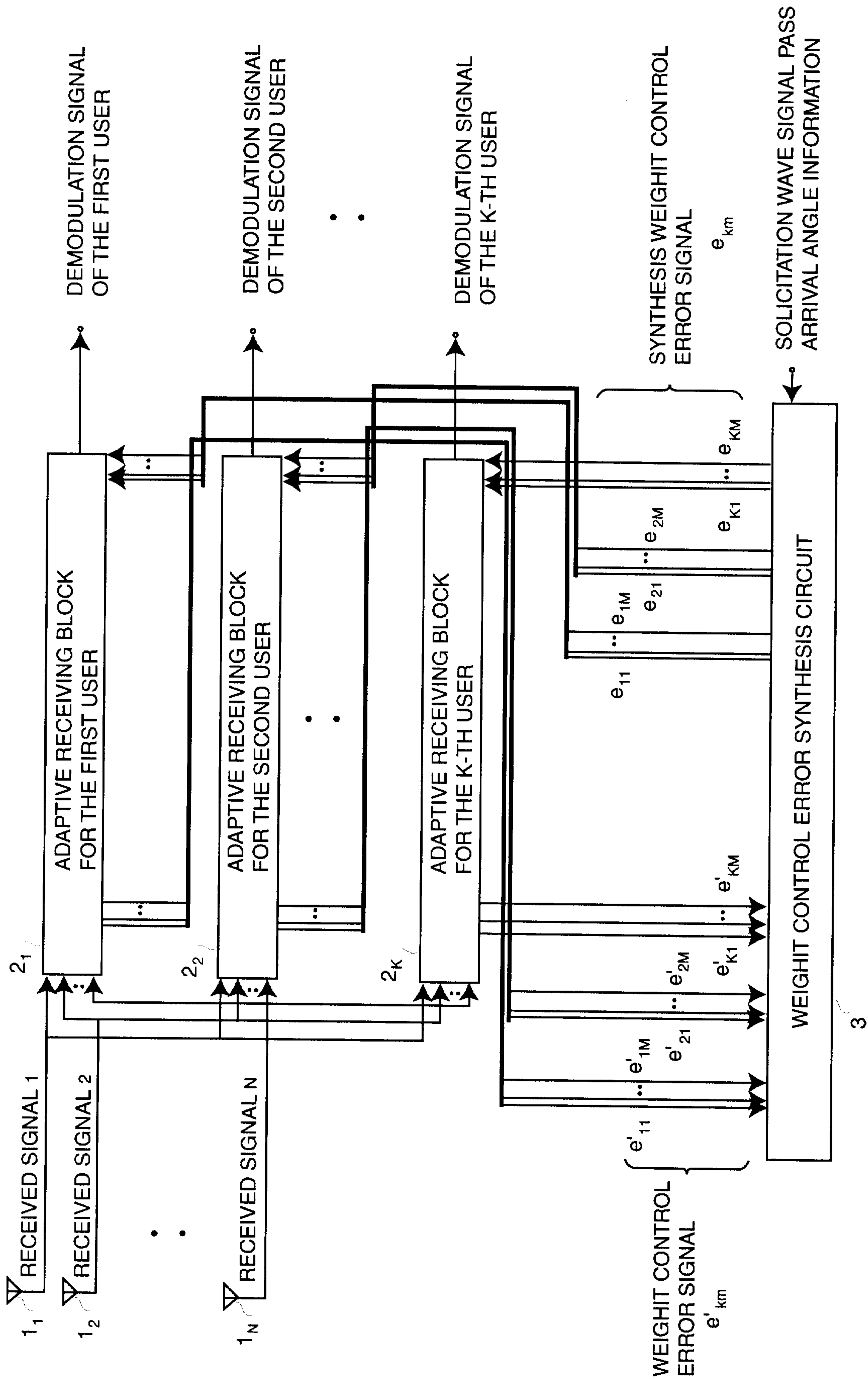

FIG.2

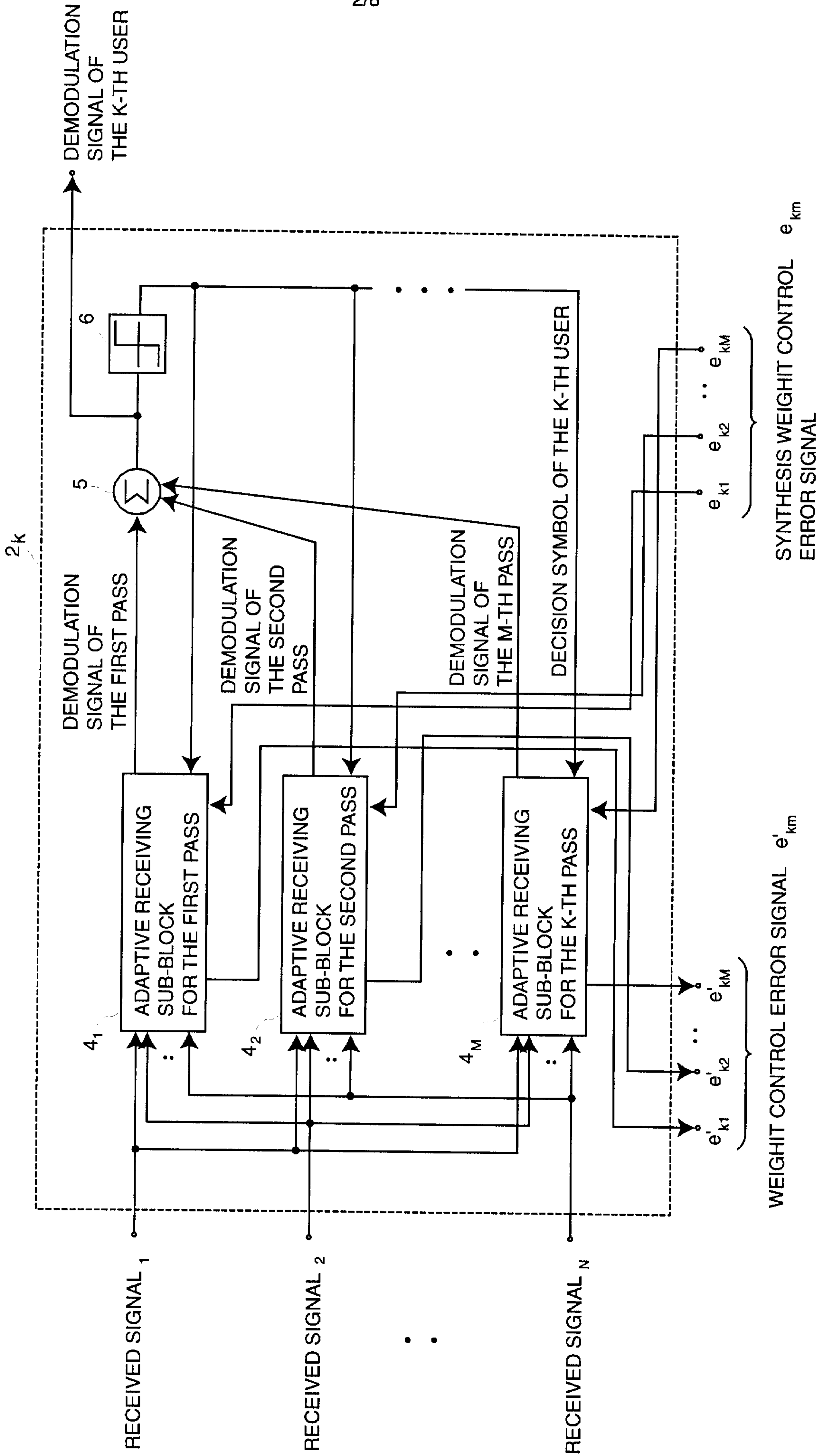

FIG.3

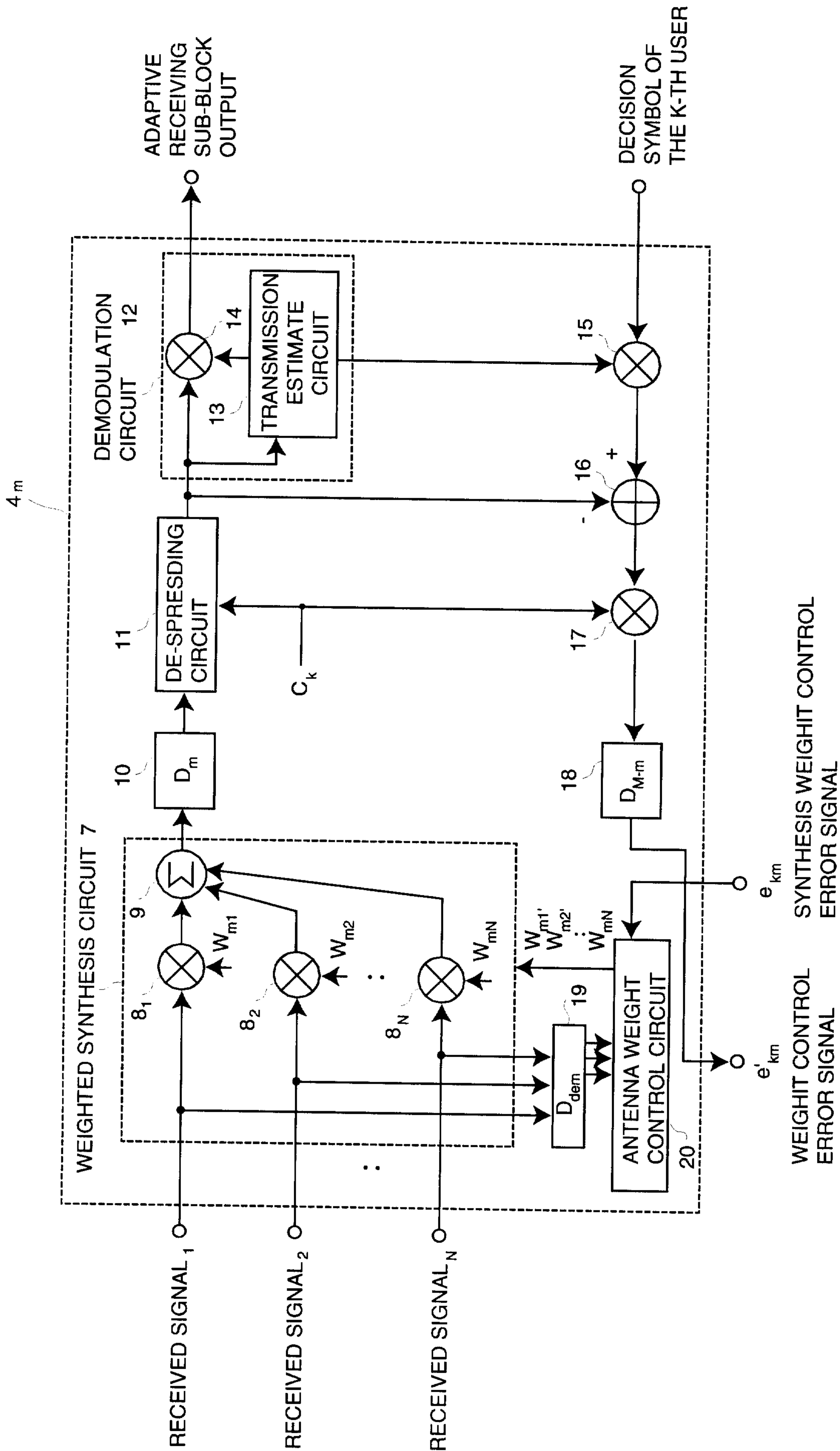

FIG.4

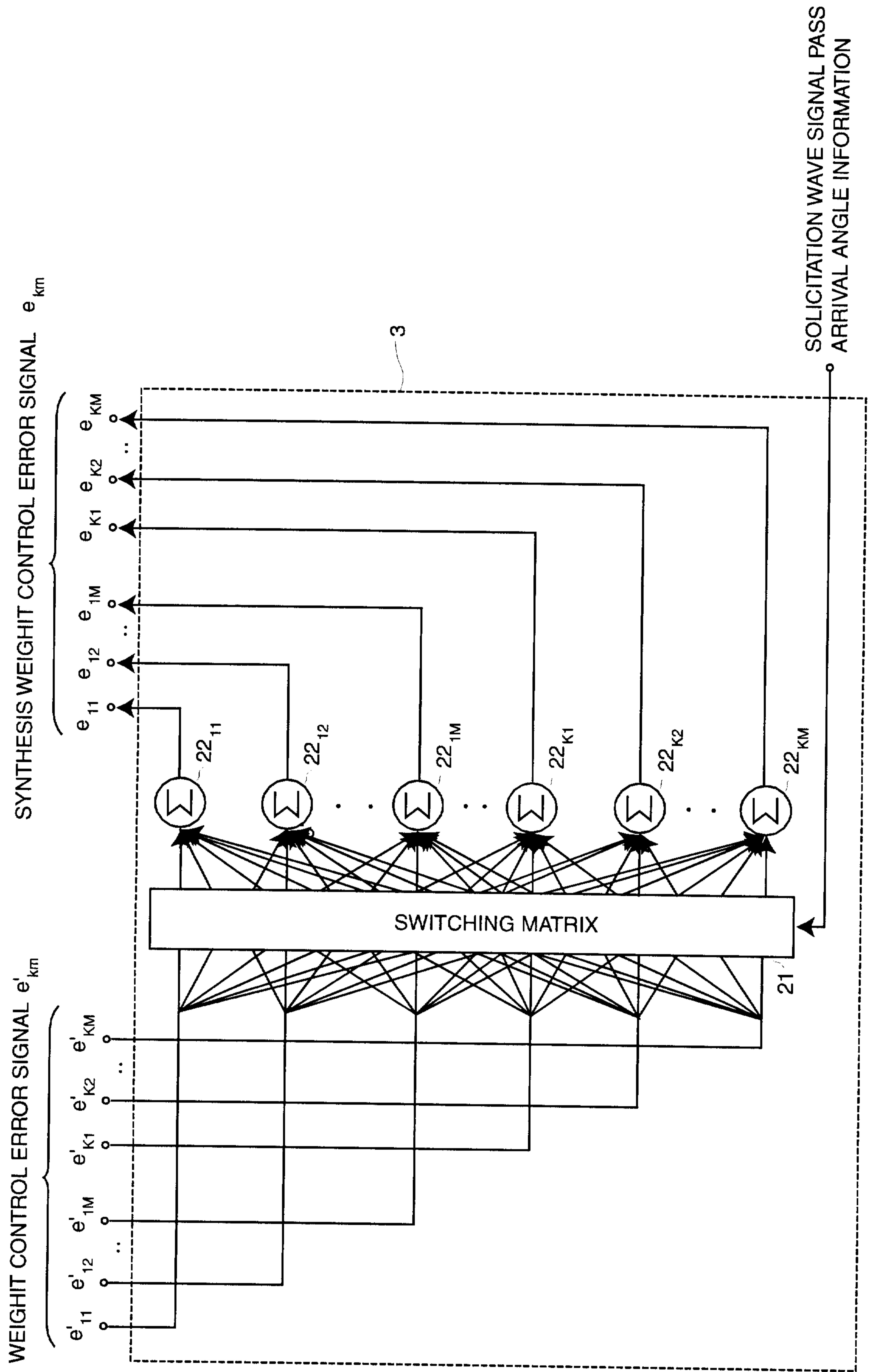

FIG.5

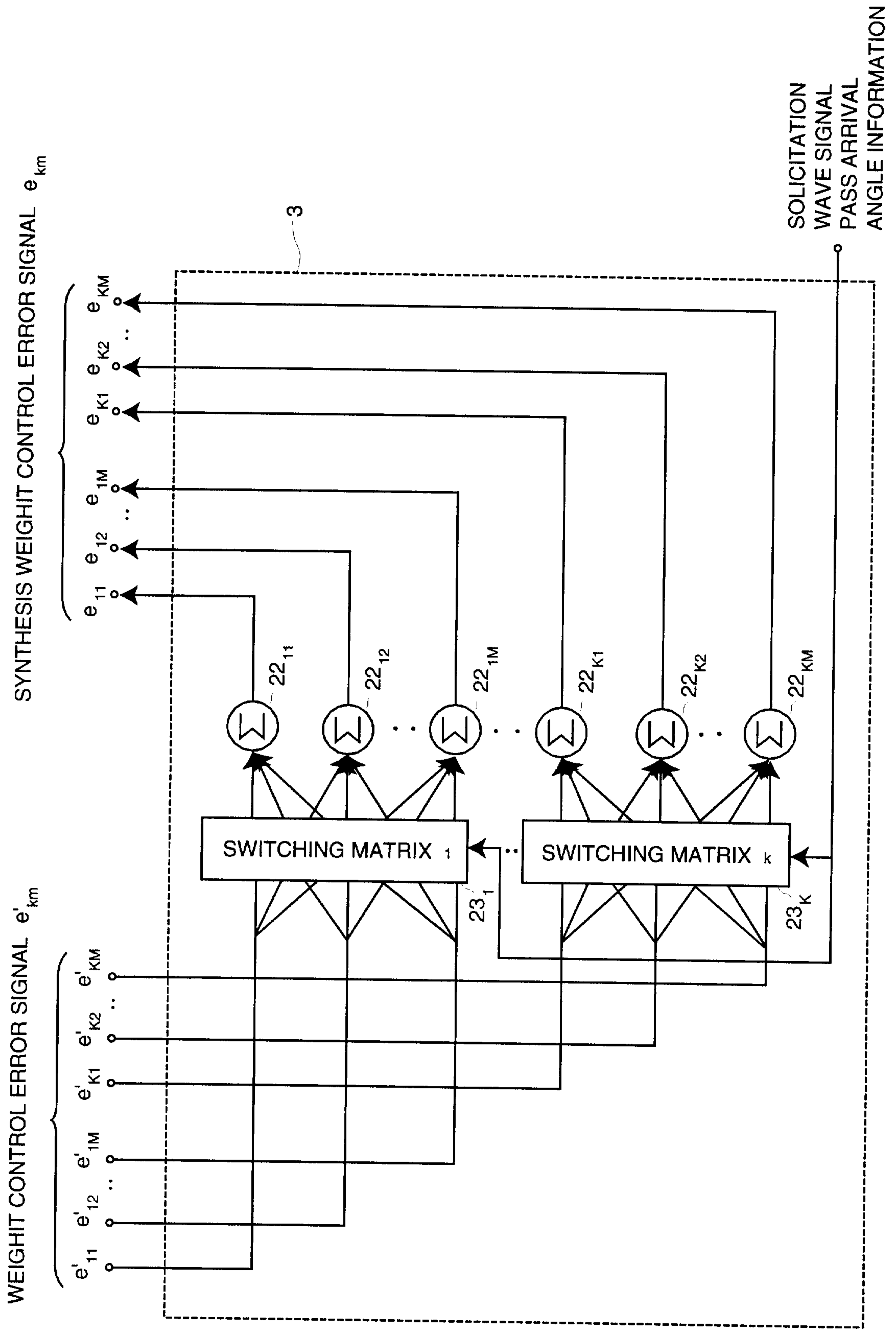

FIG.6

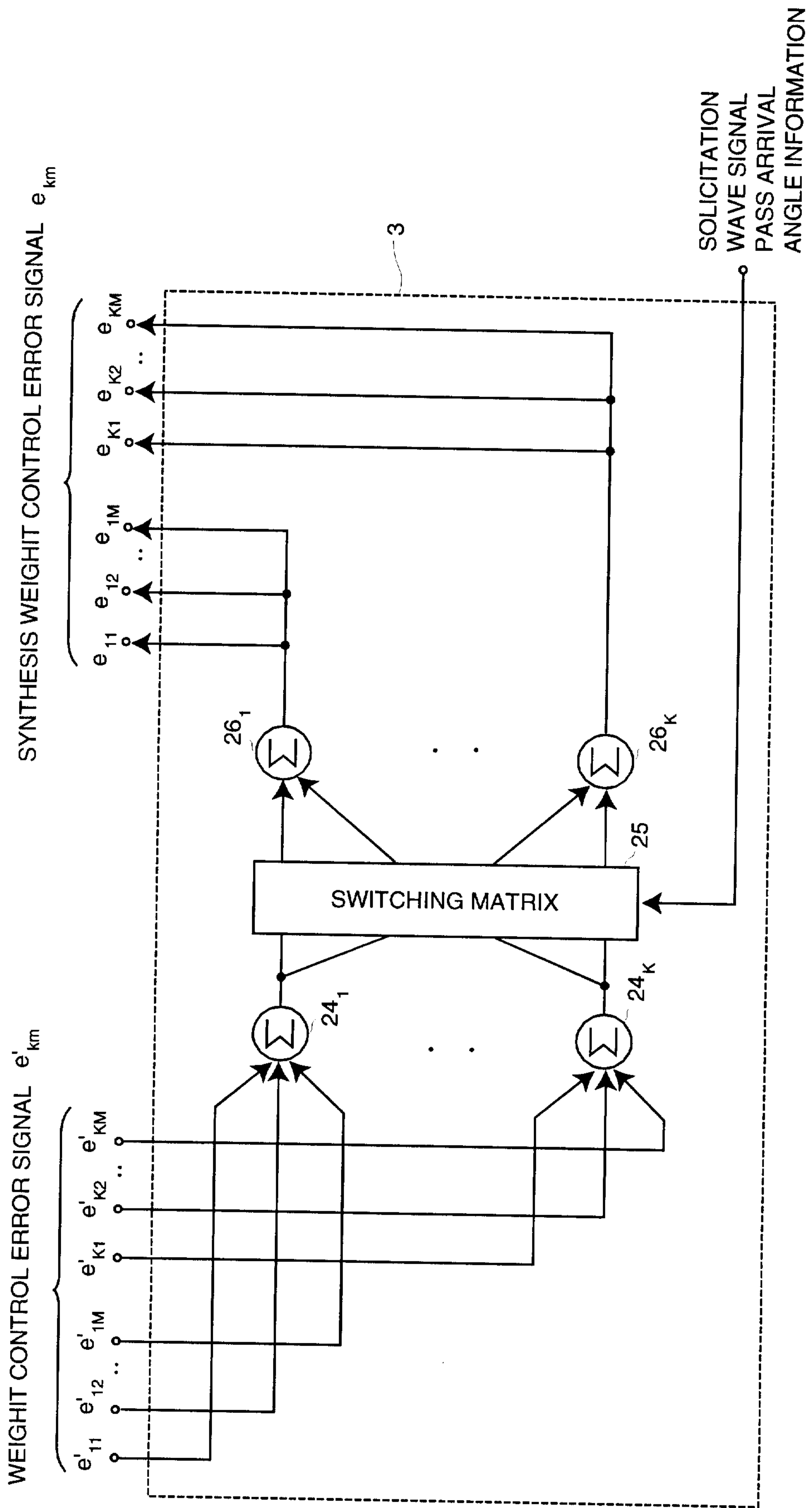

FIG.7

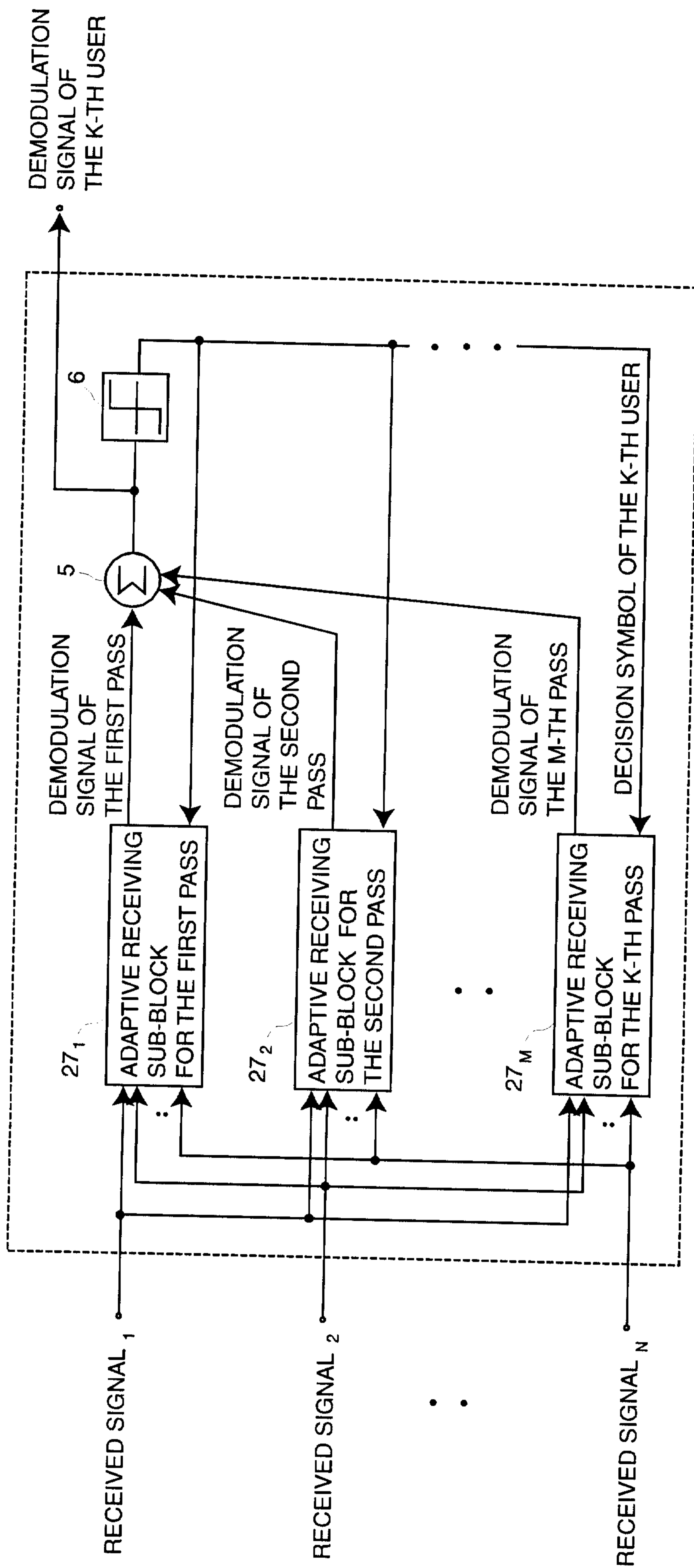

FIG.8

