

W. O. HILLS.
Burglar Alarm.

No. 52,999.

Patented March 6, 1866.

Fig. 2

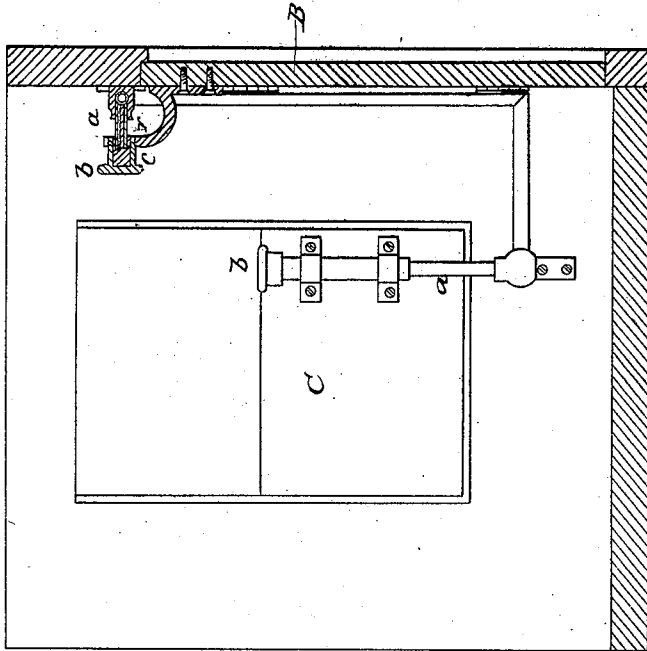
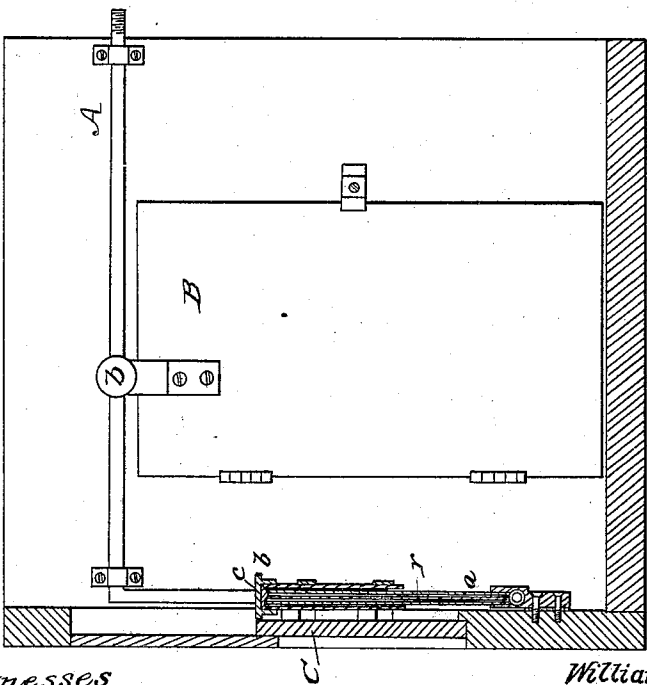

Fig. 1



Witnesses
Samuel C. Piper
G. H. Washburn.

Inventor
William O. Hills.
by his attorney
R. H. Ledy

UNITED STATES PATENT OFFICE.

WILLIAM O. HILLS, OF NOTTINGHAM, NEW HAMPSHIRE,

BURGLAR-ALARM.

Specification forming part of Letters Patent No. 52,999, dated March 6, 1866.

To all whom it may concern:

Be it known that I, WILLIAM O. HILLS, of Nottingham, in the county of Rockingham and State of New Hampshire, have made a new and useful improvement or invention having reference to an alarm or apparatus to signalize the attempt of a person to raise the window or open the door of a building; and I do hereby declare the same to be fully described in the following specification and represented in the accompanying drawings, of which—

Figure 1 denotes a vertical section of my apparatus as applied to a window, and also its application to the door of a room. Fig. 2 is a vertical section of that part of it which is applied to the door.

On the 31st day of August, A. D. 1858, Letters Patent No. 21,339 were granted to me for a prison-alarm, the purpose of such being to sound an alarm should an attempt be made by a prisoner to saw, cut, or break asunder one of the bars of the window or door gratings of his cell. For this purpose the said grating was composed of tubes and had connected with it an ordinary clock-alarm mechanism and a separate cylinder and piston to be operated by an air-pump.

My present invention consists in a mechanism by which an alarm and its air-cylinder and piston and an air-pump, substantially as described in the specification of the said patent, may be so applied to the window or door of an ordinary dwelling-house that an attempt to move the sash of the window or to open the door will cause the alarm apparatus to be set in operation so as to sound an alarm.

In the drawings, A denotes a tube to extend along over a door, B, and to have a branch, a, erected on it vertically near the window-sash C, (see Fig. 1;) or it may have such a branch tube extended from it horizontally over the door, as shown in Fig. 2.

A valve tube or cap, b, carrying an elastic stopper, c, to close down upon and estop the open end of the branch tube, is applied to the sash or to the door.

When the window-sash or door is closed, the branch tube a extends into the valve-tube b,

and also against the stopper c, which may be a piece of vulcanized caoutchouc.

The tube A is to be connected and so as to communicate with the air-conduit leading to the air-cylinder of the alarm apparatus.

If, by means of air forced into the cylinder, we suppose the piston of the said cylinder to be raised, so as to prevent the alarm-hammer from sounding the bell while the door or sash is closed, an attempt to open either the sash or the door will cause the valve-stopper of such door or sash to be moved off the branch pipe so as to allow the air from the cylinder to escape, in which case the piston will be depressed so as to set free the alarm and enable it to sound and give warning of the attempt to raise the sash or to open the door.

In order to prevent a burglar, on opening the sash or door, from suddenly compressing the branch pipe so as to prevent the escape of air therefrom, there may be placed within the pipe a rod, r, having a diameter less than that of the bore of the pipe, or such a shape in cross-section as will render it difficult for a compression of the pipe to prevent the escape of air from it.

The invention may be applied to the upper sash of the window, in which case the branch pipe should stand with its mouth downward and the valve-stopper be so arranged as to be drawn away from the open end of the branch tube.

If desirable, a pressure-gage may be applied to the conduit A to indicate the amount of pressure of the air.

What I claim as my invention is—

1. The combination of the branch a and the valve-stopper c, or the equivalents thereof, with a sash or door and the air-pipe A of an alarm apparatus of the kind to which reference has been hereinbefore made.

2. The combination of the rod r, or its equivalent, with the branch tube a, when used substantially as and for the purpose specified.

WILLIAM O. HILLS.

Witnesses:

A. J. HOYT,
WARREN HOYT.