

(12) **United States Patent**  
**Nichols**

(10) **Patent No.:** **US 11,430,350 B2**  
(45) **Date of Patent:** **Aug. 30, 2022**

(54) **MULTI-PURPOSE SIGNAGE ASSEMBLY**  
(71) Applicant: **James W. Nichols**, Lewis Center, OH (US)  
(72) Inventor: **James W. Nichols**, Lewis Center, OH (US)  
(\* ) Notice: Subject to any disclaimer, the term of this patent is extended or adjusted under 35 U.S.C. 154(b) by 0 days.  
(21) Appl. No.: **17/328,361**

4,613,847 A \* 9/1986 Scolari ..... B60Q 7/00  
362/418  
4,751,494 A \* 6/1988 Crotwell ..... B60Q 1/50  
40/592  
7,296,373 B1 \* 11/2007 Hahn ..... G09F 15/0012  
40/658  
7,591,095 B2 \* 9/2009 Kollmann ..... B60Q 7/02  
40/607.04  
7,631,467 B2 \* 12/2009 Clarke ..... F16B 12/00  
52/285.3  
7,992,333 B1 \* 8/2011 McGuinness ..... G09F 21/04  
116/28 R  
8,146,279 B2 \* 4/2012 Elmer ..... G09F 21/04  
40/592

(22) Filed: **May 24, 2021**

(Continued)

(65) **Prior Publication Data**

US 2021/0375162 A1 Dec. 2, 2021

*Primary Examiner* — David R Dunn

*Assistant Examiner* — Christopher E Veraa

(74) *Attorney, Agent, or Firm* — C. Fred Charpie, III;  
Ward Law Office LLC

**Related U.S. Application Data**

(60) Provisional application No. 63/030,125, filed on May 26, 2020.

(57) **ABSTRACT**

A multi-purpose signage assembly is provided. The multi-purpose signage assembly including a framework having a plurality of edges. The edges bounding opposing first and second panels. A first screen received by the first panel and a second screen received by the second panel. One of the plurality of edges having a plurality of slot assemblies. Another of the plurality of edges having a plurality of slot assemblies. A plurality of opposing magnets positioned in the plurality of slot assemblies of one of the edges or the slot assemblies of the other edge. The plurality of opposing magnets configured to attract each other in a manner such as to retain the opposing magnets in the slot assemblies. The plurality of opposing magnets further configured to attach the multi-purpose signage assembly to a ferrous surface with sufficient magnetic force to maintain the multi-purpose signage assembly in place.

(51) **Int. Cl.**  
**G09F 7/18** (2006.01)

(52) **U.S. Cl.**  
CPC ..... **G09F 7/18** (2013.01); **G09F 2007/1843** (2013.01); **G09F 2007/1852** (2013.01); **G09F 2007/1865** (2013.01)

(58) **Field of Classification Search**  
None  
See application file for complete search history.

(56) **References Cited**

U.S. PATENT DOCUMENTS

3,762,360 A \* 10/1973 Hawes ..... B60Q 7/005  
116/28 R  
4,609,133 A \* 9/1986 Anderson ..... B60Q 1/50  
224/317

**18 Claims, 11 Drawing Sheets**

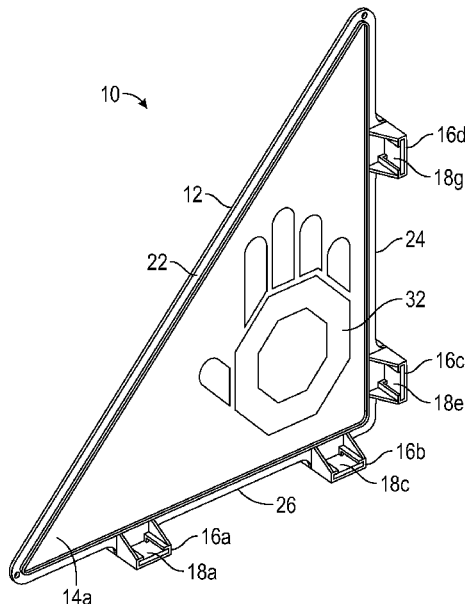

(56)

**References Cited**

U.S. PATENT DOCUMENTS

8,742,917 B2\* 6/2014 Ho ..... B60Q 7/00  
116/63 P  
2006/0021267 A1\* 2/2006 Matsuda ..... G02B 6/0053  
40/546  
2010/0290212 A1\* 11/2010 Francis ..... G09F 7/04  
362/97.3  
2013/0160336 A1\* 6/2013 Harman, Jr. .... G09F 13/00  
40/591  
2017/0053574 A1\* 2/2017 Byrd ..... G09F 21/04  
2019/0232860 A1\* 8/2019 Ferrone ..... B60Q 1/2615

\* cited by examiner

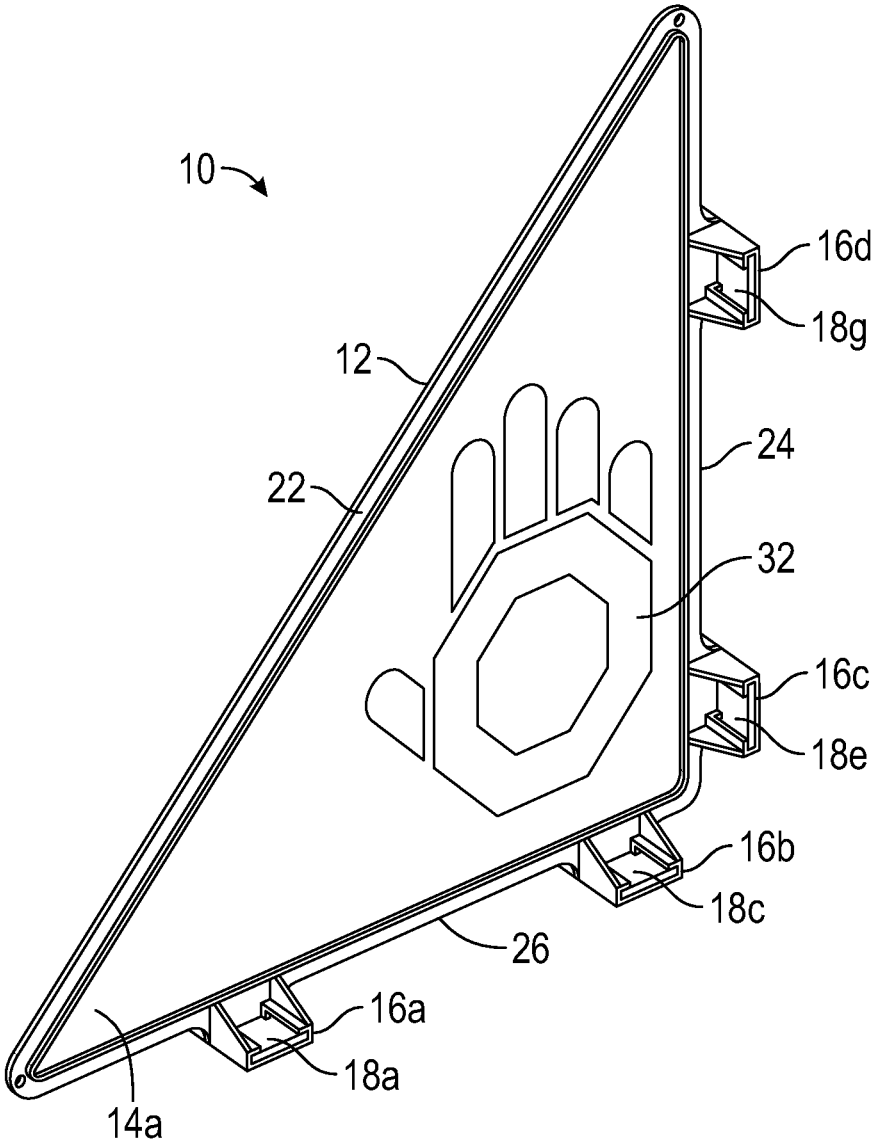

FIG. 1

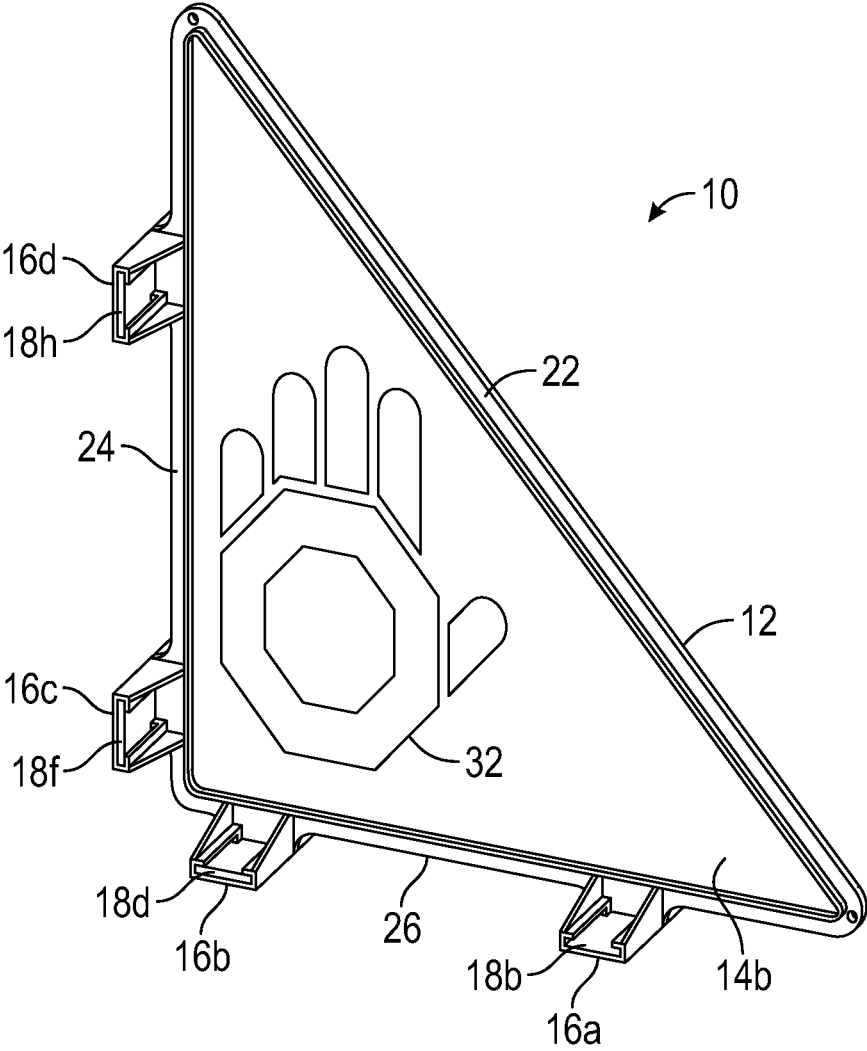

FIG. 2

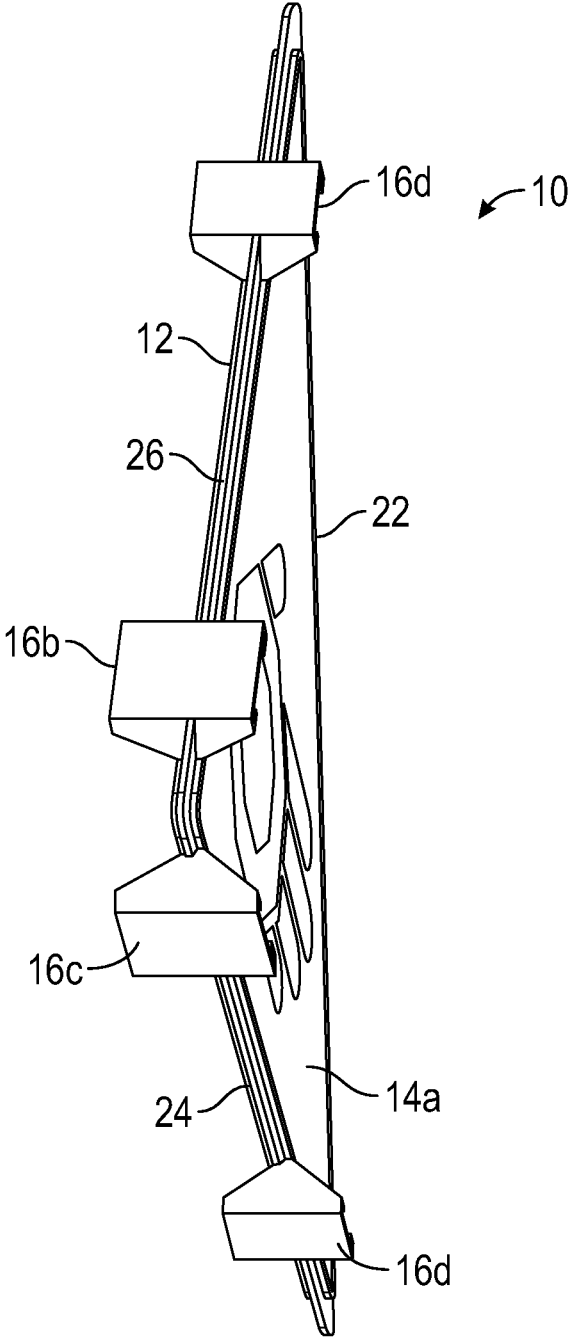

FIG. 3

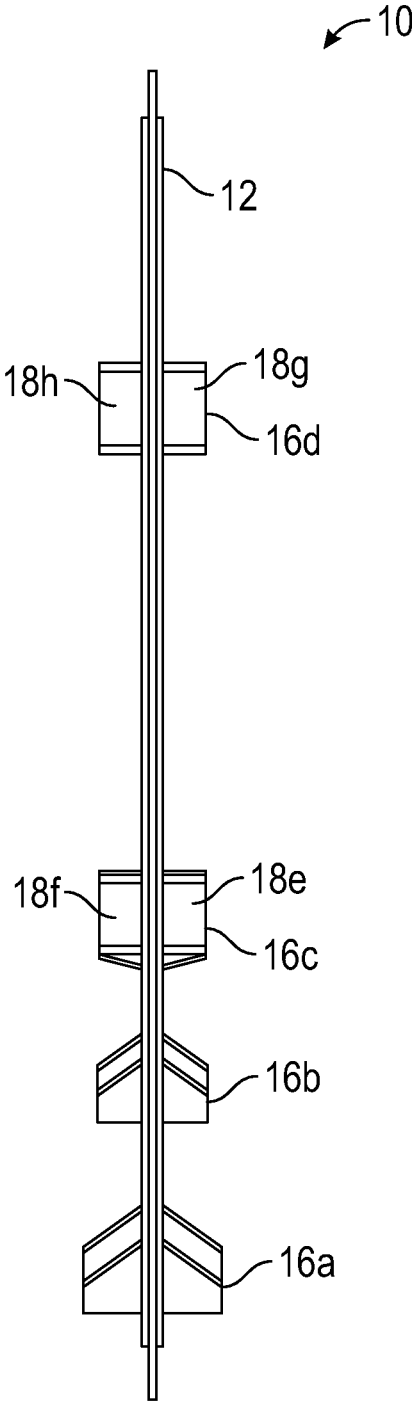

FIG. 4

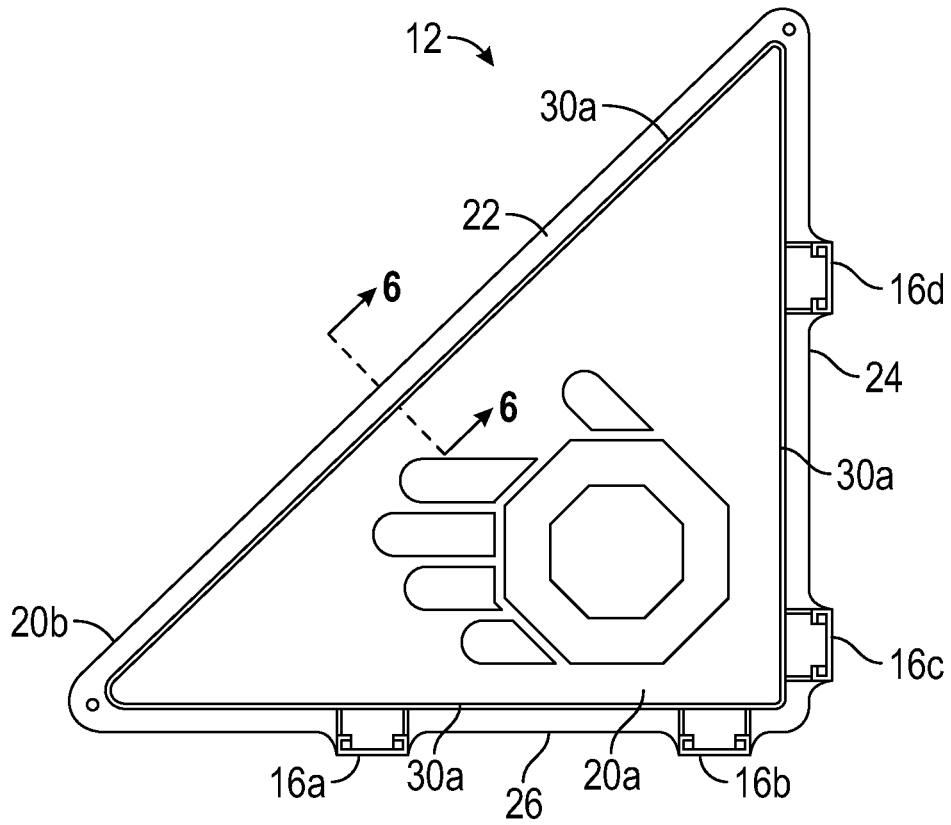

FIG. 5

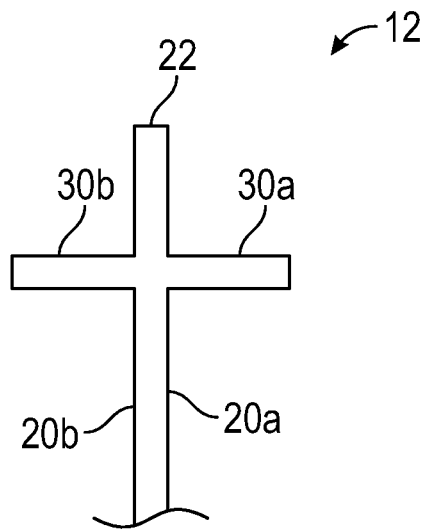

FIG. 6

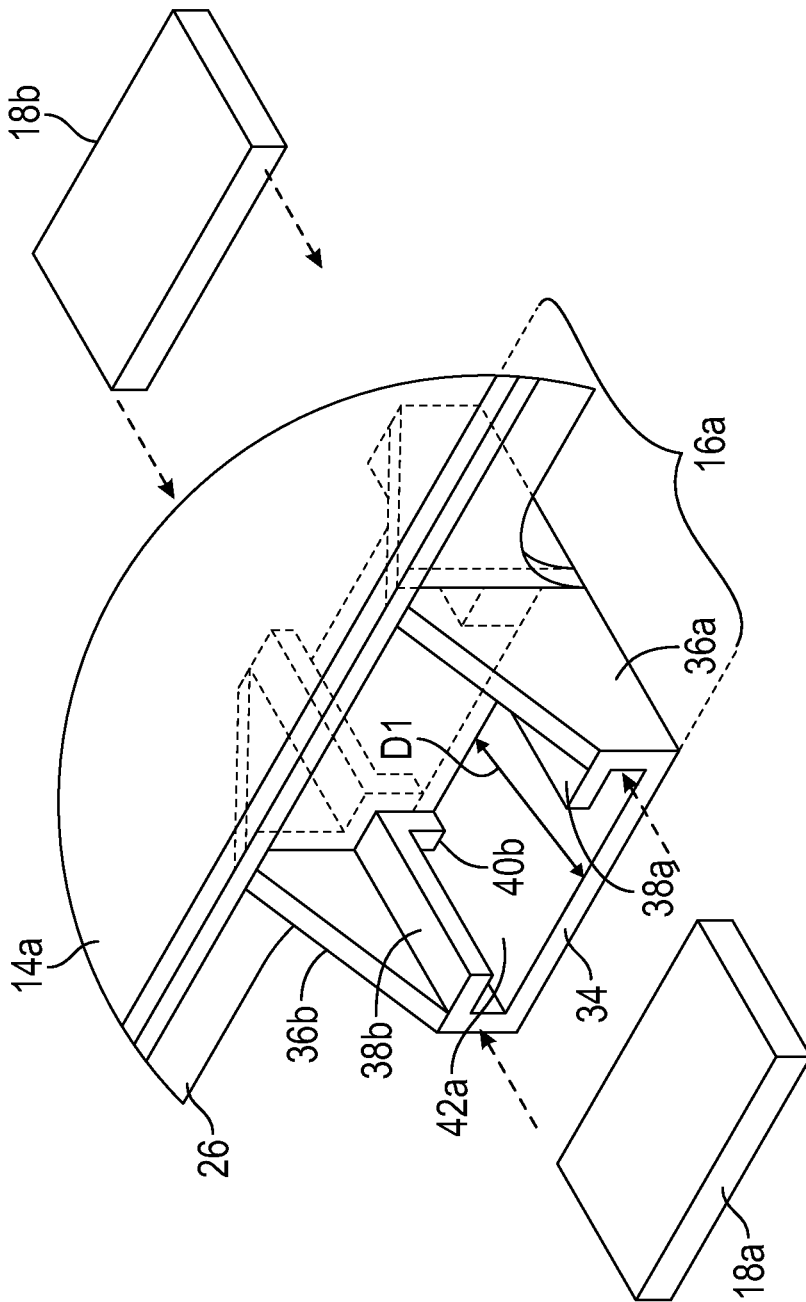

FIG. 7

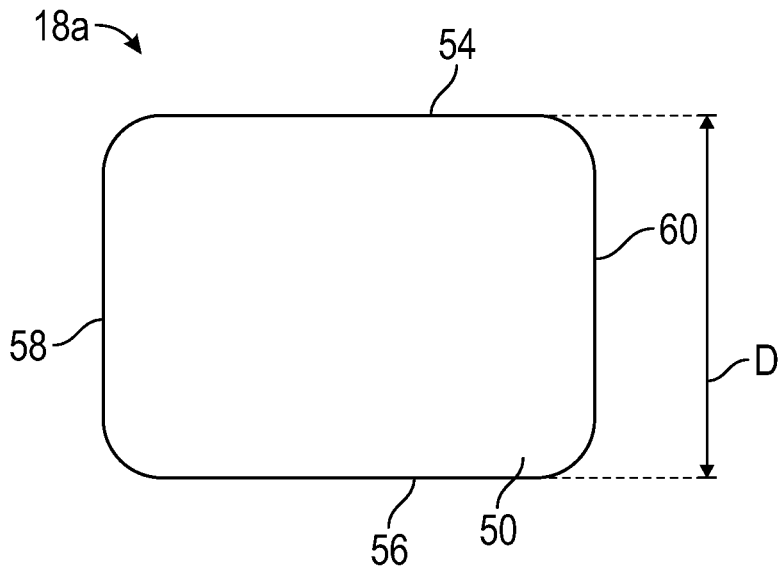

FIG. 8A

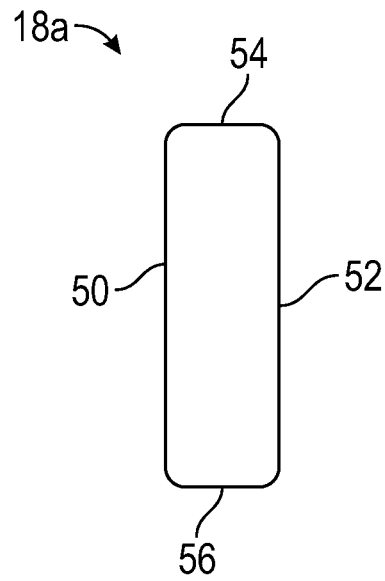

FIG. 8B

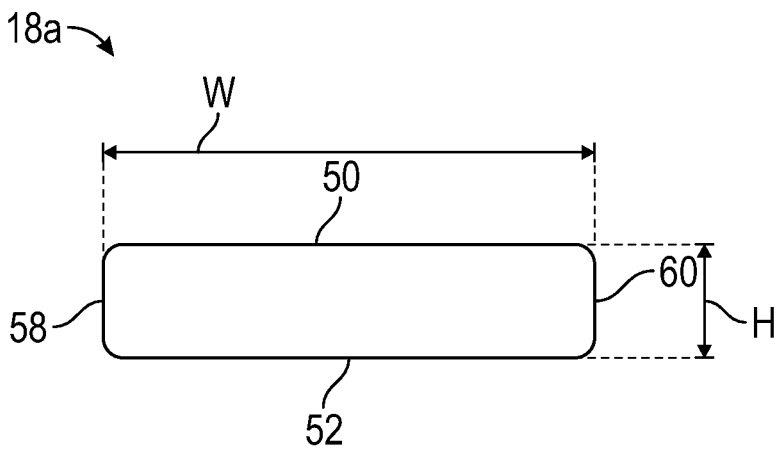

FIG. 8C

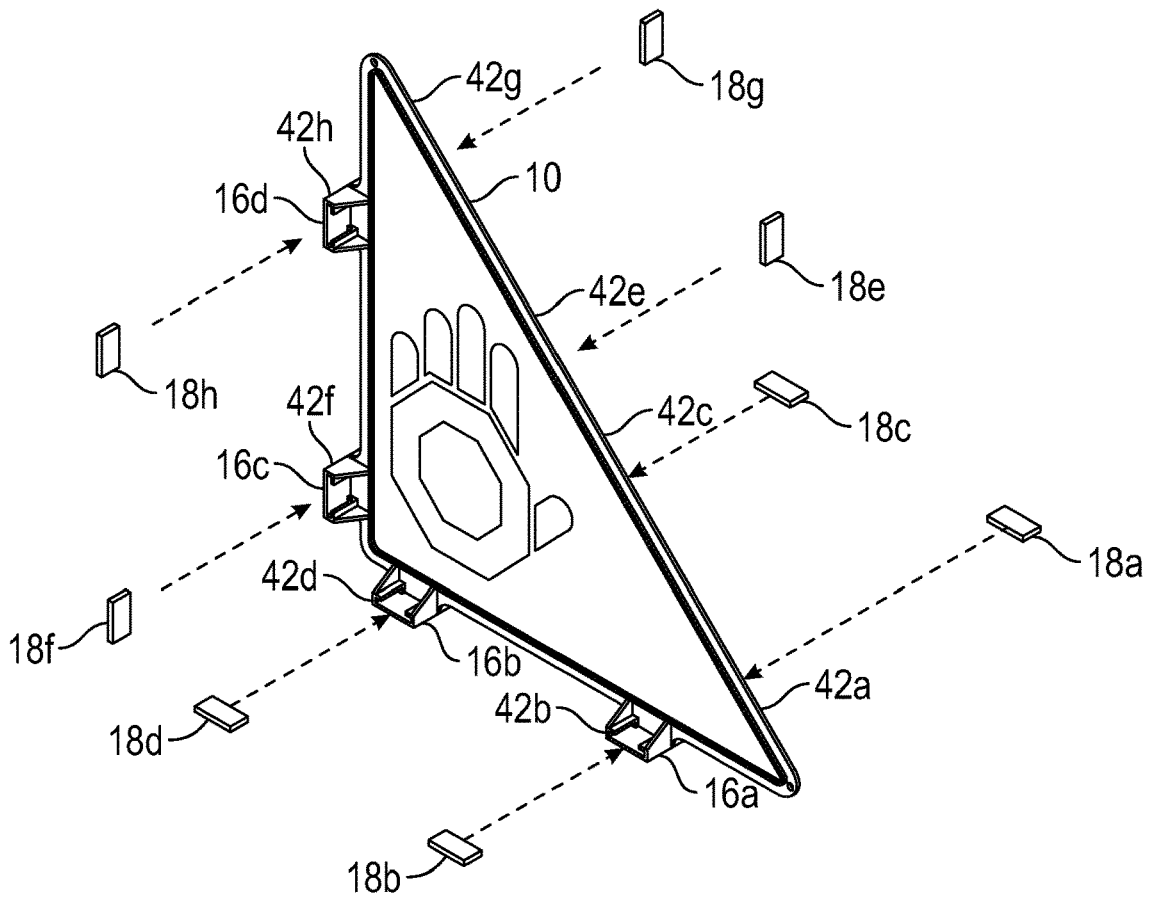

FIG. 9

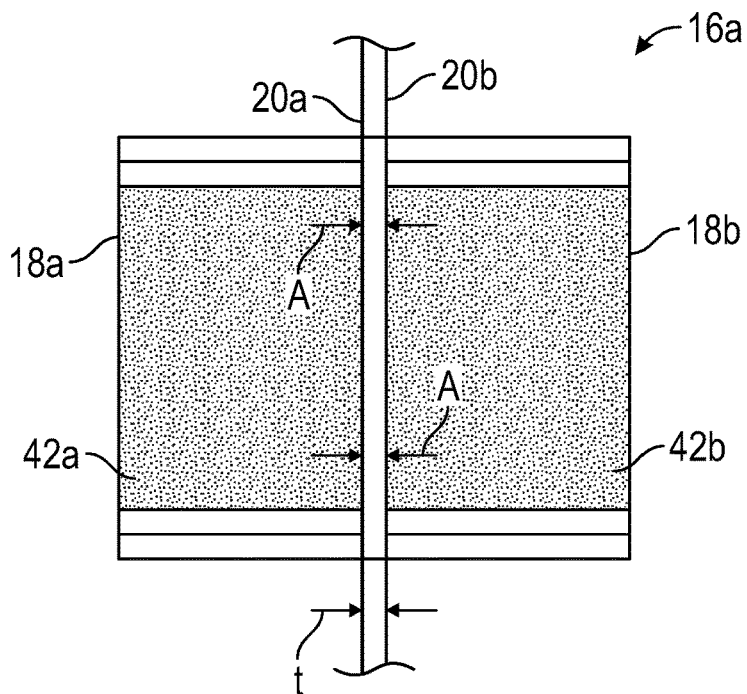

FIG. 10

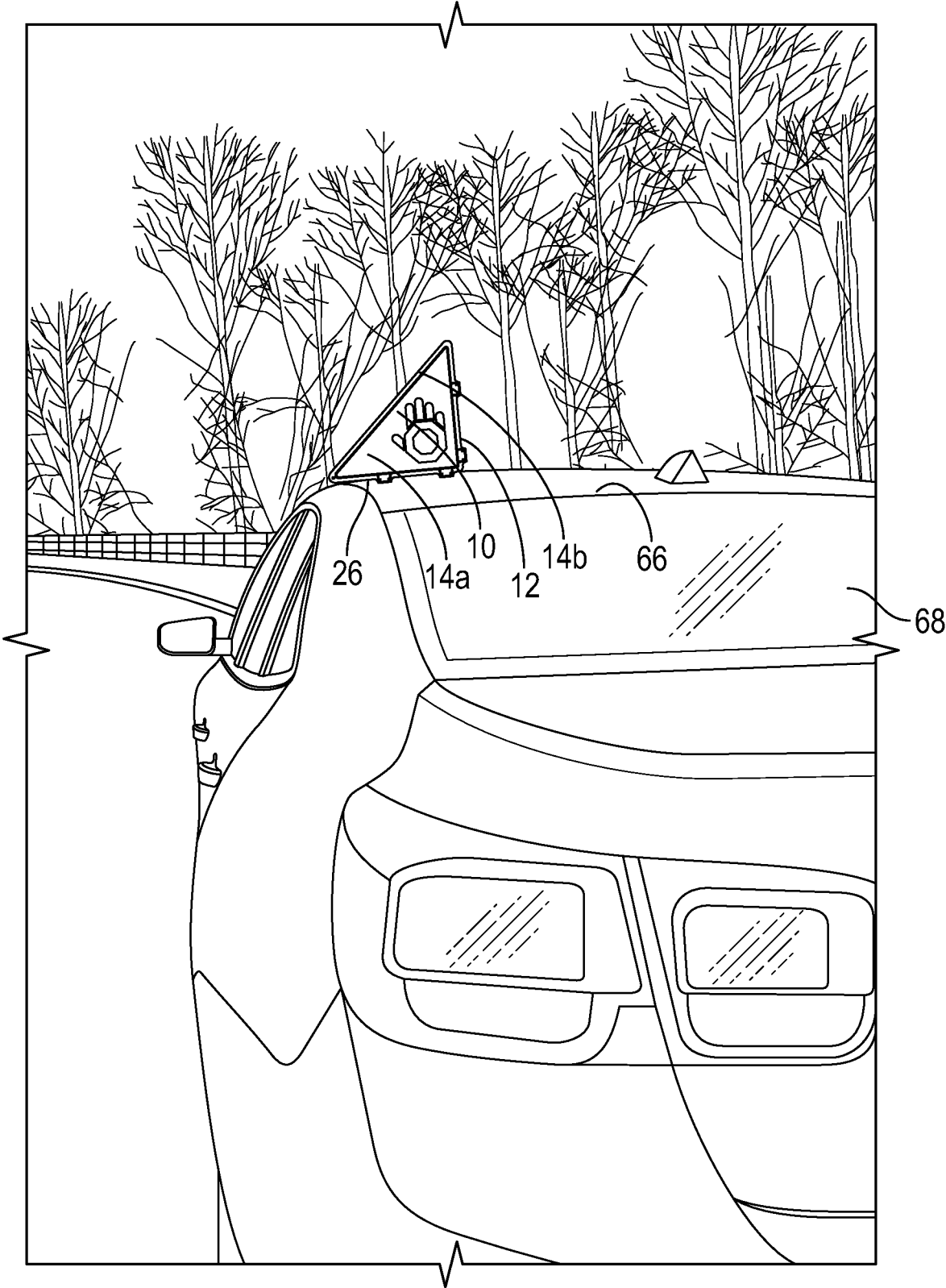

FIG. 11

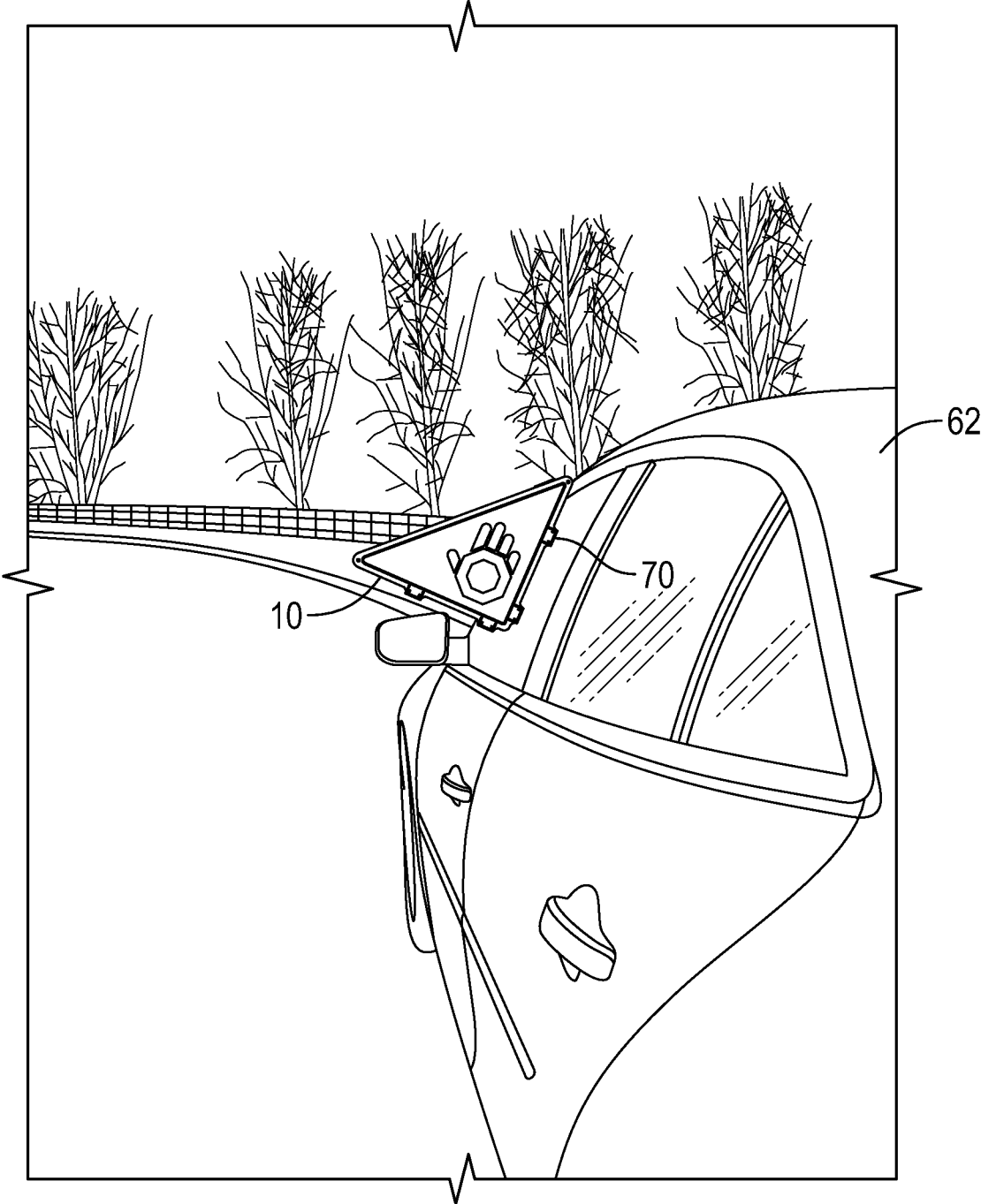

FIG. 12

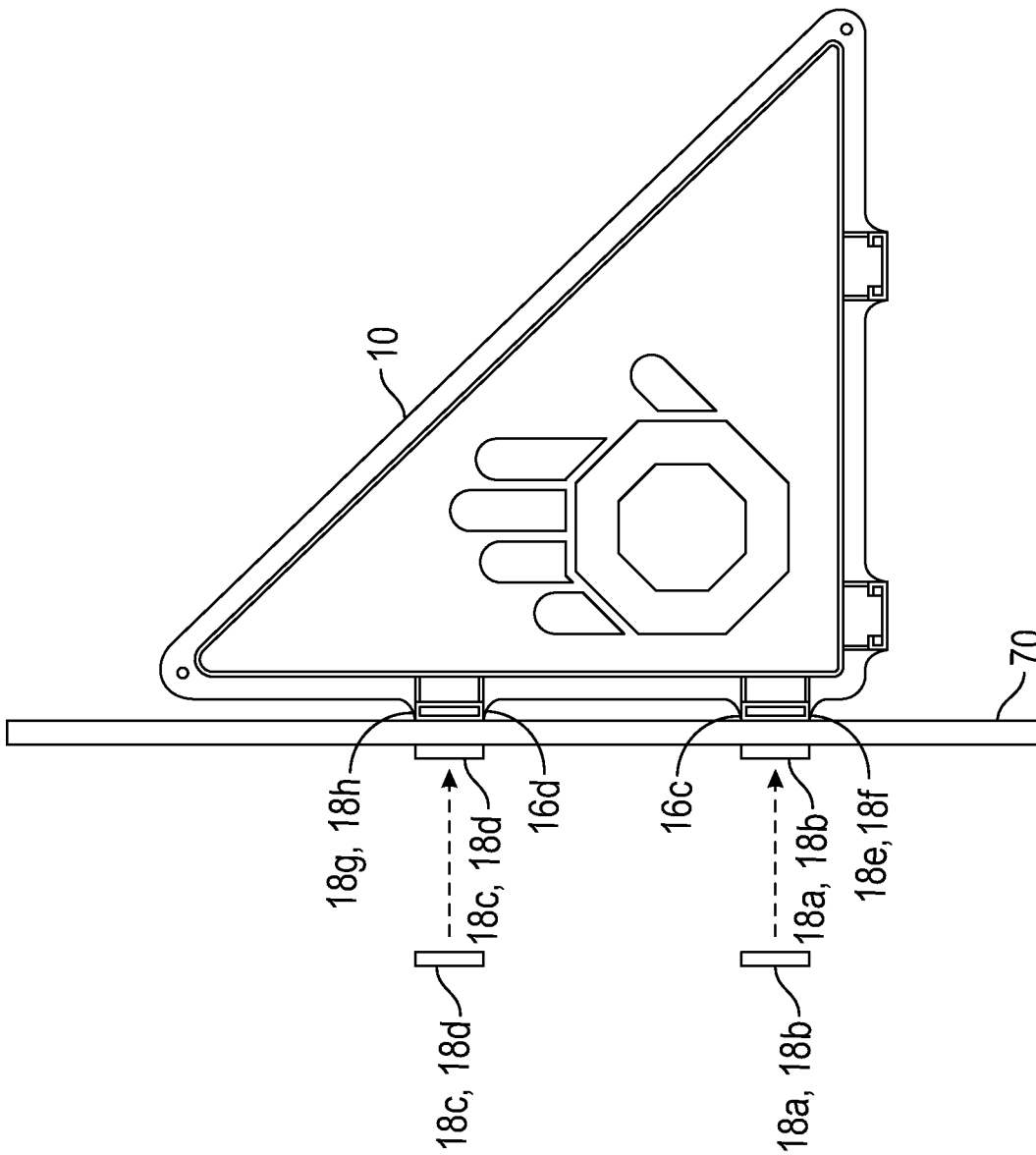

FIG.13

**MULTI-PURPOSE SIGNAGE ASSEMBLY**

## RELATED APPLICATIONS

This application claims the benefit of pending U.S. Provisional Patent Application No. 63/030,125, filed May 26, 2020, the disclosure of which is incorporated herein by reference in its entirety

## BACKGROUND

In certain situations, a person may require assistance. The need for assistance can stem from a variety of situations including the non-limiting examples of a stalled vehicle, medical emergencies, losing direction during a hike in the woods, accidents and the like. In these instances, it can be desirable to alert other persons of the need for assistance.

Signage and signage assemblies can be used to alert others as to the need for assistance. Certain issues are noted in the structure, construction and use of prior art signage. The issues include the non-limiting examples of a lack of visibility, difficulties in the attachment and/or removal of the signage from the attachment location and difficulties in application to non-ferrous surfaces.

It would be advantageous if signage assemblies could be improved for use in multiple applications.

## SUMMARY

It should be appreciated that this Summary is provided to introduce a selection of concepts in a simplified form, the concepts being further described below in the Detailed Description. This Summary is not intended to identify key features or essential features of this disclosure, nor it is intended to limit the scope of the multi-purpose signage assembly.

The above objects as well as other objects not specifically enumerated are achieved by a multi-purpose signage assembly. The multi-purpose signage assembly including a framework having a plurality of edges. The edges bounding opposing first and second panels. A first screen received by the first panel and a second screen received by the second panel. One of the plurality of edges having a plurality of slot assemblies. Another of the plurality of edges having a plurality of slot assemblies. A plurality of opposing magnets positioned in the plurality of slot assemblies of one of the edges or the slot assemblies of the other edge. The plurality of opposing magnets configured to attract each other in a manner such as to retain the opposing magnets in the slot assemblies. The plurality of opposing magnets further configured to attach the multi-purpose signage assembly to a ferrous surface with sufficient magnetic force to maintain the multi-purpose signage assembly in place.

The above objects as well as other objects not specifically enumerated are also achieved by a multi-purpose signage assembly. The multi-purpose signage assembly includes a framework having a plurality of edge. The edges bounding opposing first and second panels. The framework positioned on one side of a non-ferrous material. A first screen received by the first panel and a second screen received by the second panel. One of the plurality of edges having a plurality of slot assemblies. Another of the plurality of edges having a plurality of slot assemblies. A first plurality of opposing magnets positioned in the plurality of slot assemblies of one of the edges or the slot assemblies of the other edge. The first plurality of opposing magnets configured to attract each other in a manner such as to retain the opposing magnets in

the slot assemblies. A second plurality of opposing magnets positioned on an opposing side of the non-ferrous material and configured to attract to the first plurality of opposing magnets with sufficient magnetic force to maintain the multi-purpose signage assembly in place against the non-ferrous material.

Various objects and advantages of the multi-purpose signage assembly will become apparent to those skilled in the art from the following Detailed Description, when read in light of the accompanying drawings.

## BRIEF DESCRIPTION OF THE DRAWINGS

FIG. 1 is a left side perspective view of a multi-purpose signage assembly in accordance with the invention.

FIG. 2 is a right side perspective view of the multi-purpose signage assembly of FIG. 1.

FIG. 3 is a rear perspective view of the multi-purpose signage assembly of FIG. 1.

FIG. 4 is a front view of the multi-purpose signage assembly of FIG. 1.

FIG. 5 is a side perspective view of a framework of the multi-purpose signage assembly of FIG. 1.

FIG. 6 is a cross-sectional view of a portion of a first edge of the framework of FIG. 5.

FIG. 7 is a perspective view of opposing slot assemblies of the multi-purpose signage assembly of FIG. 1.

FIG. 8A is a plan view of a magnet of the multi-purpose signage assembly of FIG. 1.

FIG. 8B is a side view of the magnet of FIG. 8A.

FIG. 8C is a front view of the magnet of FIG. 8A.

FIG. 9 is a perspective view of a framework of the multi-purpose signage assembly of FIG. 1, illustrating insertion of a plurality of magnets of FIGS. 8A-8C.

FIG. 10 is a plan view of the opposing slot assemblies of FIG. 7 showing opposing magnets in an installed arrangement.

FIG. 11 is a perspective view of a first installation arrangement of the multi-purpose signage assembly of FIG. 1.

FIG. 12 is a perspective view of a second installation arrangement of the multi-purpose signage assembly of FIG. 1.

FIG. 13 is a side view of the second installation arrangement of the multi-purpose signage assembly of FIG. 1.

## DETAILED DESCRIPTION

The multi-purpose signage assembly will now be described with occasional reference to specific embodiments. The multi-purpose signage assembly may, however, be embodied in different forms and should not be construed as limited to the embodiments set forth herein. Rather, these embodiments are provided so that this disclosure will be thorough and complete, and will fully convey the scope of the multi-purpose signage assembly to those skilled in the art.

Unless otherwise defined, all technical and scientific terms used herein have the same meaning as commonly understood by one of ordinary skill in the art to which the multi-purpose signage assembly belongs. The terminology used in the description of the multi-purpose signage assembly herein is for describing particular embodiments only and is not intended to be limiting of the multi-purpose signage assembly. As used in the description of the multi-purpose signage assembly and the appended claims, the singular

forms “a,” “an,” and “the” are intended to include the plural forms as well, unless the context clearly indicates otherwise.

Unless otherwise indicated, all numbers expressing quantities of dimensions such as length, width, height, and so forth as used in the specification and claims are to be understood as being modified in all instances by the term “about.” Accordingly, unless otherwise indicated, the numerical properties set forth in the specification and claims are approximations that may vary depending on the desired properties sought to be obtained in embodiments of the multi-purpose signage assembly. Notwithstanding that the numerical ranges and parameters setting forth the broad scope of the multi-purpose signage assembly are approximations, the numerical values set forth in the specific examples are reported as precisely as possible. Any numerical values, however, inherently contain certain errors necessarily resulting from error found in their respective measurements.

Referring now to FIG. 1-4, a multi-purpose signage assembly (hereafter “signage assembly”) is illustrated generally at 10. The signage assembly 10 is configured for several functions. First, the signage assembly 10 is configured to alert a person of the need for assistance. Second, the signage assembly 10 is configured for attachment to a variety of surfaces, in a variety of positions and orientations, with a novel attachment system. Finally, the signage assembly 10 is configured to draw attention from afar, with highly visible screens formed from one or more reflective materials. The signage assembly 10 includes a framework 12, a plurality of opposing first and second screens 14a, 14b, a plurality of spaced apart slot assemblies 16a-16d and a plurality of magnets 18a-18h.

Referring now to FIG. 5, the framework 12 is illustrated. The framework 12 includes a first panel 20a and an opposing second panel 20b. The first panel 20a is configured to receive the first screen 14a and the second panel 20b is configured to receive the second screen 14b. The first and second panels 20a, 20b are bounded by a first edge 22, a second edge 24 and a third edge 26. The edges 22, 24, 26 cooperate to form a triangular shape with the first edge forming a hypotenuse 22. In the embodiment shown in FIG. 5, the edges 22, 24, 26 cooperate to form an isosceles right triangle. However, in other embodiments, the edges 22, 24, 26 can cooperate to form other triangular shapes. While the embodiment illustrated in FIGS. 1-5 shows the framework 12 as having the form of a triangle, it should be appreciated that in other embodiments, other desired shapes can be used, such as the non-limiting examples of square shapes, rectangular shapes, octagonal shapes and the like.

Referring now to FIG. 6, a portion of the first edge 22, first panel 20a and second panel 20b of the framework 12 is illustrated in cross-section. The cross-section of the first edge 22 is representative of the cross-sections of the second and third edges 24, 26. A first rib 30a, positioned proximate the first edge 22, extends in a substantially perpendicular direction from the first panel 20a. Similarly, an opposing second rib 30b, positioned proximate the first edge 22 extends in a substantially perpendicular direction from the second panel 20b.

Referring again to FIG. 5, the first rib 30a and the second rib (not shown) extend along and proximate to the first, second and third edges 22, 24, 26. The first rib 30a and the second rib are configured to provide structural support to the framework 12. In the embodiment illustrated in FIG. 5, the first rib 30a positioned proximate the first, second and third edges 22, 24, 26 forms a continuous circumferential structure. In a similar manner, the second rib positioned proximate

the first, second and third edges 22, 24, 26 forms a continuous circumferential structure. The continuous structures formed by each of the first and second ribs 30a, 30b is configured to provide structural support to the framework 12. However, it should be appreciated that in other embodiments, each of the first and second ribs 30a, 30b can form discontinuous structures, sufficient to provide structural support to the framework 12.

Referring now to the embodiment illustrated in FIG. 6, the first and second ribs 30a, 30b each have an identical rectangular cross-sectional shape. In alternate embodiments, it is contemplated the first and second ribs and have other cross-sectional shapes and the cross-sectional shapes of the first and second ribs 30a, 30b can be different from each other, sufficient to provide structural support to the framework 12.

Referring again to the embodiment shown in FIG. 5, the framework 12 includes the plurality of slot assemblies 16a-16d. The slot assemblies 16a-16d will be discussed in more detail below. The framework 12, including the plurality of slot assemblies 16a-16d, is formed as a unitary, one-piece assembly. The unitary, one piece assembly advantageously provides structural support to the signage assembly 10. However, in other embodiments, the framework 12 can be configured from discrete elements that are assembled together.

Referring again to FIG. 5, the framework 12 is formed from a polymeric material, such as the non-limiting example of high-density polyethylene, configured to provide resistance against environmental elements and further configured to provide structural support to the framework 12. In alternate embodiments, the framework 12 can be formed from other suitable materials, sufficient to provide resistance against environmental elements and further configured to provide structural support to the framework 12.

Referring again to FIGS. 1 and 2, the reflective material forming the first screen 14a is applied to the first panel 20a and the reflective material forming the second screen 14b is applied to the panel 20b. In the illustrated embodiment, the first and second screens 14a, 14b are mirror images of each other, although such is not necessary for operation of the signage assembly 10. The reflective material forming the first and second screens 14a, 14b can be applied to the first and second panels 20a, 20b in any desired manner, including the non-limiting example of self-sticking adhesives.

Referring now to FIGS. 1 and 2, each of the first and second screens 14a, 14b has an outward face formed with a highly reflective and visible material. The highly reflective and visible material is configured to draw attention from afar. In the illustrated embodiment, the highly reflective and visible material is formed with full-cube prismatic technology, such as for example 3M™ Diamond Grade™ Reflective Sheeting, manufactured and marketed by 3M Corporation, headquartered in St. Paul, Minn. However, in other embodiments, other highly reflective and visible material can be used sufficient to draw attention from afar.

Referring again to FIGS. 1 and 2, optionally indicia 32 can be added to the outward faces of the first and second screens 14a, 14b. The indicia 32 can represent any desired symbol or message, such as the non-limiting examples of warnings messages and/or messages configured to draw attention and/or summon help.

Referring now to FIGS. 1-4, the spaced apart slot assemblies 16a and 16b extend from a portion of the third edge 26 and radially from the first and second panels 20a, 20b of the framework 12. In a similar manner, the spaced apart slot assemblies 16c and 16d extend from a portion of the second

edge **24** and extend radially from the first and second panels **20a**, **20b** of the framework **12**. While the illustrated embodiment shows a quantity of two slot assemblies forming a portion of each of the first and second edges **24**, **26**, in other embodiments, more or less than two slot assemblies can form a portion of each of the first and second edges **24**, **26** of the framework **12**.

Referring now to FIG. 7, the first screen **14a**, slot assemblies **16a**, **16b**, and third edge **26** are illustrated. The slot assembly **16a** is representative of the slot assemblies **16b-16d**. Generally, the slot assembly **16a** is configured to receive and position a magnet **18a** in a desired alignment with a magnet **18b** inserted into the slot assembly **16b**. The slot assembly **16a** includes a base wall **34**, opposing first and second side walls **36a**, **36b** extending from the base wall **34** and retaining walls **38a**, **38b** extending from the opposing first and second side walls **36a**, **36b**. Opposing first and second retaining walls **38a**, **38b** extend from the opposing first and second side walls **36a**, **36b** in a direction toward each other. A first back wall (not shown for purposes of clarity) is positioned adjacent the third edge **26** and extends from the first retaining wall **38a** to the base wall **34**. In a similar manner, a second back wall **40b** is positioned adjacent the third edge **26** and extends from the second retaining wall **38b** to the base wall **34**.

Referring again to FIG. 7, taken together, the base wall **34**, first and second side walls **36a**, **36b**, first and second retaining walls **38a**, **38b** and the first and second back walls **40a**, **40b** define a magnet cavity **42a**. The magnet cavity **42a** has a rectangular cross-sectional shape that approximates a rectangular cross-sectional shape of the magnet **18a**. The magnet cavity **42a** extends inward in a direction toward the third edge **26** of framework **12** a distance **D1**. The distance **D1** is limited by a thickness of the first and second back walls **40a**, **40b**.

Referring again to FIG. 7, an opposing magnet cavity **42b** is formed in the opposing slot assembly **16b**. The opposing magnet cavity **42b** in slot assembly **16b** is aligned with the magnet cavity **42a** in the slot assembly **16a** and extends inward in a direction toward the third edge **26** of framework **12**.

Referring now to FIGS. **8A-8C**, the magnet **18a** is illustrated. The magnet **18a** is representative of the magnets **18b-18h**. The magnet **18a** has a rectangular cross-sectional shape and size with first and second major faces **50**, **52**, first and second longitudinal edges **54**, **56** and first and second lateral edges **58**, **60**. It should be appreciated that the magnets **18a-18h** can have other shapes and sizes sufficient for the purposes described herein. The magnet **18a** has a width **W**, a depth **D** and a height **H**. In the illustrated embodiment, the width **W** is about 1.000 inches, the depth **D** is about 0.500 inches and the height **H** is about 0.125 inches. In other embodiments, the width **W** can be more or less than about 1.000 inches, the depth **D** can be more or less than about 0.500 inches and the height **H** can be more or less than about 0.125 inches, sufficient for the purposes described herein. Advantageously, the magnets **18a-18h** and their associated magnet cavities **42a-42h** are sized in a manner such that the magnets **18a-18h** freely slip into the cavities **42a-42h** without interference and without the need for special installation tools.

Referring again to FIGS. **8A-8C**, the magnet **18a** is a rare earth permanent magnet and is formed from a metal alloy material or combination of metal alloy materials having extremely high magnetic properties. Acceptable metal alloy materials include neodymium iron boron (Nd—Fe—B), samarium cobalt (SmCo<sub>5</sub> or Sm<sub>2</sub>Co<sub>17</sub>) and aluminum

nickel cobalt (AlNiCo), although other metal alloys can be used. In the illustrated embodiment, the magnet **18a** has a pull force in a range of from about 5.0 lbs to about 15.0 lbs and a surface field in a range of from about 4,000 Gauss to about 8,000 Gauss. However, in other embodiments, the magnet **18a** can have a pull force less than about 5.0 lbs or more than about 15.0 lbs and a surface field less than about 4,000 Gauss or more than about 8,000 Gauss, sufficient for the functions described herein. One non-limiting example of a suitable magnet **18a** is the neodymium block magnet model number BX028, marketed by K&J Magnetics Inc., headquartered in Pipersville, Pa., although other magnets can be used.

Referring again to FIGS. **1** and **2**, while the illustrated embodiment shows a lone magnet **18a-18h** seated in the respective cavities of the slot assemblies **16a-16d**, it should be appreciated that in other embodiments, a plurality of magnets can be seated in the respective cavities of the slot assemblies **16a-16d**.

Referring now to FIG. **9**, the magnets **18a-18d** are shown in a generally horizontal orientation prior to insertion into the magnet cavities **42a-42d** formed in the respective slot assemblies **16a** and **16b**. The magnets **18e-18h** are shown in a generally vertical orientation prior to insertion into the magnet cavities **42e-42h** formed in the respective slot assemblies **16c** and **16d**. Advantageously, insertion of the magnets **18a-18h** into their respective magnet cavities **42a-42h** and removal of the magnets **18a-18h** from their respective magnet cavities **42a-42h** can be accomplished manually and without the need for special tools, tooling, mechanisms or apparatus.

Referring now to FIG. **10**, the slot assembly **16a** is illustrated with each of the opposing magnets **18a**, **18b** in a seated position within their respective magnet cavities **42a**, **42b**. When installed in the magnet cavities **42a**, **42b**, the opposing magnets **18a**, **18b** are separated by a thickness **t** of the framework **12** forming the first and second panels **20a**, **20b**. Further when installed in the magnet cavities **42a**, **42b**, the opposing magnets **18a**, **18b** are configured with sufficient magnetic strength that they attract each other in a manner (schematically shown by magnetic attraction arrows **A**) such that additional retention structures, mechanisms and devices are unnecessary to maintain the magnets **18a**, **18b** in their respective cavities. As should be appreciated, the thickness **t** and the magnetic strength of the opposing magnets **18a**, **18b** can be adjusted in a manner such that additional retention structures, mechanisms and devices are unnecessary to maintain the magnets **18a**, **18b** in their respective cavities.

Referring now to FIG. **11**, the signage assembly **10** is shown in a first installation arrangement. In this arrangement, the side **26** of the framework **12** is positioned adjacent a ferrous surface **66** of an automobile **68**. In this position, the magnets **18a-18d** positioned in the slot assemblies **16a**, **16b** are attracted to the ferrous surface **66** with sufficient magnetic force to maintain the signage assembly **10** in place. Accordingly, it should be appreciated that each of the opposing pairs of magnets provided the dual functions of attraction to each other to maintain the magnets in their respective cavities and also attraction of the signage assembly **10** to the ferrous surface **66** with sufficient magnetic force to maintain the signage assembly **10** in place. It should be noted that in the first installation arrangement, the signage assembly **10** is orientated with the first and second screens **14a**, **14b** arranged to be substantially perpendicular to a longitudinal axis of the automobile **68**, thereby providing maximum visibility to engaging traffic. In other embodi-

ments, the first and second screens **14a**, **14b** can have other arrangements to maximize visibility.

Referring now to FIGS. **12** and **13**, the signage assembly **10** is shown in a second installation arrangement. In this arrangement, the signage assembly **10** is equipped with a quantity of eight (8) magnets **18a-18h** and the signage assembly **10** is fixed against a non-ferrous surface, such as the non-limiting example of glass window **70** of the automobile **62**. In this position, the magnets **18e**, **18f**, **18g** and **18h** are positioned in the slot assemblies **16c**, **16d** and the slot assemblies **16c**, **16d** are positioned against one surface of the window **70**. Two pairs of opposing magnets **18a**, **18b**, **18c** and **18d** are positioned on the opposite side of the window **70**. The four pairs of magnets: **18a** and **18b**, **18c** and **18d**, **18e** and **18f** and **18g** and **18h** are aligned with each other such that the magnets on opposing sides of the window **70** are attracted to each other with sufficient magnetic force to maintain the signage assembly **10** in place.

While the multi-purpose signage assembly is described above and shown in FIGS. **1-3** and **11-13** as having one or more highly reflective and visible screens **14a**, **14b**, it is contemplated that the multi-purpose signage assembly could incorporate screens configured to be highly visible with other structures, features, mechanisms and devices, such as the non-limiting examples of one or more screens that illuminate or glow.

In accordance with the provisions of the patent statutes, the principle and mode of operation of the multi-purpose signage assembly have been explained and illustrated in certain embodiments. However, it must be understood that the multi-purpose signage assembly may be practiced otherwise than as specifically explained and illustrated without departing from its spirit or scope.

What is claimed is:

1. A multi-purpose signage assembly comprising:
  - a framework having a plurality of edges, the edges bounding opposing first and second panels;
  - a first screen received by the first panel;
  - a second screen received by the second panel;
  - one of the plurality of edges having a plurality of slot assemblies;
  - another of the plurality of edges having a plurality of slot assemblies, wherein one of the slot assemblies has a cavity defined by a base wall, opposing first and second side walls, first and second retaining walls and first and second back walls;
  - a plurality of opposing magnets positioned in the plurality of slot assemblies of one of the edges or the slot assemblies of the other edge, wherein the plurality of opposing magnets are configured to attract each other in a manner such as to retain the opposing magnets in the slot assemblies, the plurality of opposing magnets further configured to attach the multi-purpose signage assembly to a ferrous surface with sufficient magnetic force to maintain the multi-purpose signage assembly in place.
2. The multi-purpose signage assembly of claim 1, wherein the framework has a quantity of three edges and forms a triangular shape.
3. The multi-purpose signage assembly of claim 1, wherein the cavity has a rectangular cross-sectional shape.
4. The multi-purpose signage assembly of claim 3, wherein all of the slot assemblies have the same structure.
5. The multi-purpose signage assembly of claim 1, wherein the opposing magnets in a slot assembly are separated from each other by a portion of the framework.

6. The multi-purpose signage assembly of claim 1, wherein the framework includes a circumferential rib positioned proximate each of the edges.

7. The multi-purpose signage assembly of claim 1, wherein the first and second screens each have the form of a reflective panel incorporating full-cube prismatic technology.

8. The multi-purpose signage assembly of claim 1, wherein the magnets are configured for manual insertion into their respective slot assemblies and removal from their respective slot assemblies without the need for special tools, tooling, mechanisms or apparatus.

9. The multi-purpose signage assembly of claim 1, wherein each of the magnets has the form of a rare earth permanent magnet.

10. A multi-purpose signage assembly comprising:
  - a framework having a plurality of edges, the edges bounding opposing first and second panels, the framework positioned on one side of a non-ferrous material;
  - a first screen received by the first panel;
  - a second screen received by the second panel;
  - one of the plurality of edges having a plurality of slot assemblies;
  - another of the plurality of edges having a plurality of slot assemblies, wherein one of the slot assemblies has a cavity defined by a base wall, opposing first and second side walls, first and second retaining walls and first and second back walls;
  - a first plurality of opposing magnets positioned in the plurality of slot assemblies of one of the edges or the slot assemblies of the other edge, the first plurality of opposing magnets configured to attract each other in a manner such as to retain the opposing magnets in the slot assemblies;
  - a second plurality of opposing magnets positioned on an opposing side of the non-ferrous material and configured to attract to the first plurality of opposing magnets with sufficient magnetic force to maintain the multi-purpose signage assembly in place against the non-ferrous material.

11. The multi-purpose signage assembly of claim 10, wherein the framework has a quantity of three edges and forms a triangular shape.

12. The multi-purpose signage assembly of claim 10, wherein the cavity has a rectangular cross-sectional shape.

13. The multi-purpose signage assembly of claim 10, wherein all of the slot assemblies have the same structure.

14. The multi-purpose signage assembly of claim 10, wherein the opposing magnets in a slot assembly are separated from each other by a portion of the framework.

15. The multi-purpose signage assembly of claim 10, wherein the framework includes a circumferential rib positioned proximate each of the edges.

16. The multi-purpose signage assembly of claim 10, wherein the first and second screens each have the form of a reflective panel incorporating full-cube prismatic technology.

17. The multi-purpose signage assembly of claim 10, wherein the magnets are configured for manual insertion into their respective slot assemblies and removal from their respective slot assemblies without the need for special tools, tooling, mechanisms or apparatus.

18. The multi-purpose signage assembly of claim 10, wherein each of the magnets has the form of a rare earth permanent magnet.