

*S. Cram,
Cotton Press.*

N^o 3,464.

Patented Mar. 9, 1844.

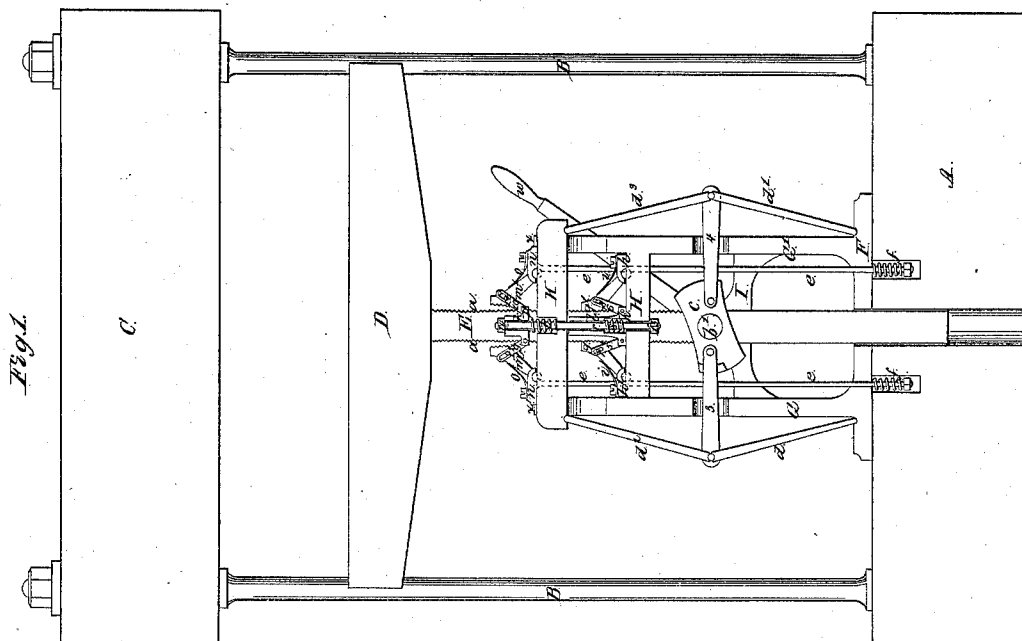
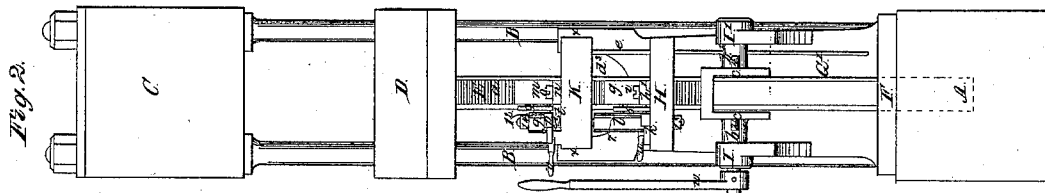
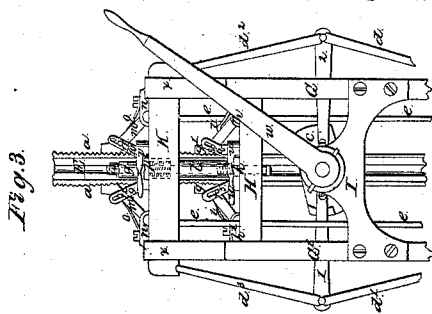

*Witnesses.
W. S. S. S. S.
Joseph Francis*

*Inventor.
Smith Cram*

UNITED STATES PATENT OFFICE.

SMITH CRAM, OF NEW YORK, N. Y.

IMPROVEMENT IN MACHINES FOR PRESSING AND RAISING WEIGHTS.

Specification forming part of Letters Patent No. 3,464, dated March 9, 1844.

To all whom it may concern:

Be it known that I, SMITH CRAM, of the city, county, and State of New York, engineer, have invented and made and applied to use certain new and useful Improvements on the Machine for Lifting Heavy Weights and Pressing Substances, for which a patent of the United States was granted to George Kilburn on the 23d day of August, 1838, and improvements added thereon by said Kilburn the 5th day of September, 1838, by an indorsement recorded the 31st day of December, 1838, the intent of my said improvements being to render the machine described and patented by said Kilburn more effective as a press for various purposes, and more readily controlled when either acting direct or when reversed in the motions, for which improvements I seek Letters Patent of the United States; and I do hereby declare that the said improvements and the mode of attaching the same to the original machine and using and working the same are fully and substantially set forth and shown in the following description and in the drawings annexed to and making part of this specification, wherein—

Figure 1 represents a front vertical and sectional elevation of the parts as I have arranged them. Fig. 2 is a similar sectional elevation of the parts seen endwise, the same letters and numbers referring to the same parts in both figures.

A are the foundation-sleepers; B B, the tie and guide rods; C, the head-block or lintel; D, the follower or platen, on the top of the metal vertical lifting and pressing shaft E, which is fitted with ratchet-teeth *a a*, and works at the lower end through the sleepers A, and through a metal bed-plate, F, which is fitted to receive two strong vertical standards, G G', finishing upward, each in a pair of strong cheek-pieces, as seen at *x*, Fig. 2.

Between the standards and below the cheeks *x* is a strong plate, forming both a cross-tie and bed-piece, H, and above this is a lifter-bed, K, sliding in and steadied between the cheeks *x*, on each side the standards G G'. The upper end of the vertical shaft E, passing through the plates H and K, receives at the top end the platen D. A pair of cross-brackets, I I', form the bearings for a two-part shaft, *b b'*, which, with the two-armed crank *c c*, formed by broad flanges, and, with the lever *w*, forms

a rock-shaft, through which the power employed is to actuate the working parts, as follows:

1 2 3 4 are pitmen or connecting rods, one end of each secured eccentrically to the crank-flanges *c c*, the other end jointed in, to form a knuckle or toggle joint with the vertical arm *d d'*, stepped at bottom, in any convenient way, on the bed-plate F and the arms *d'' d'''*, the upper ends of which fit into guide-grooves in the under side of the lifter-bed K, which is fitted with a pair of rods, *e e*, one on each side, going through the bed-plates F and H, and acting with a steady pull downward by expansive spiral springs *f f* beneath the plate F. These rods and springs are shown herein, as needful for small presses; but in larger presses the weight of the lifter-bed K will probably be enough to insure a downward motion—without these rods and springs.

On the plate H a pair of retaining-pawls, *g g'*, are fitted in joint-blocks *h h'*, the pawl-heads having teeth fitted to gear into the ratchet-teeth *a* on the shaft E.

The pawl-springs *i i* shown in the drawings may not be needed in presses of large size, as the pawls will be heavy enough to act without them.

The cylinder *l* between the plates H and K is fitted with a three-part foot-flange, *k*, two parts lying lengthwise on the plate H, and thicker than the one which lies across it. On the inside of the two thicker parts two governing-links, 5 and 6, are jointed by pins at the lower ends. The upper ends are slotted to allow a limited motion on pins 7 and 8 on this side of the pawls *g g'*. The short lever *u* has a fulcrum on the plate H, (see Fig. 3,) and the part next within the fulcrum is to overlie and hold down the third foot, or smaller flange on the lower part of the cylinder *l*, or to release the flange and cylinder if thrown back.

On the lifting bed-plate K a pair of lifting or lowering pawls, *m m'*, are fitted in joint-blocks *n*, with pawl-springs *o o*. (Shown in the drawings as behind the pawls.) These may not be needed in presses of large size. The short cylinder *q* has a three-part foot-flange, *p*, similar to that described on the cylinder *l*, the two largest parts of which are connected to the pawls *m m'* by slotted links *j* 10 taking pins 11 12 on the pawls *m m'*. The short lever *v* has a fulcrum on the lifting-bed K,

and the part next within the fulcrum is made to overlie and hold down the third foot-flange on the cylinder *g*, or release the flange and cylinder if thrown back. A single rod serving as a governor-rod, *r*, goes upward through the upper bed-piece, *H*, lower cylinder, *l*, lifting-bed *K*, and upper cylinder, *g*, with an adjusting-nut, 13, on the lower end, and a second nut, 14, on the top. This rod serves to govern the cylinders *l* and *g* and keep them in line with each other, and the nuts 13 14 time the motions of the machine by allowing the rod *r* a limited vertical motion with the cylinder *g*, which is controlled by the adjustment of the nuts above and below. The cylinders are at top only large enough to pass the rod *r*, but each is enlarged within at the bottom, so that the lower cylinder, *l*, has within it an expansive spiral spring, *s*, footing on the bed-piece *H*, and the upper cylinder, *g*, has within or beneath it a similar expansive spring, *t*, footing on the lifting bed-plate *K*. Both these springs *s* and *t* tend to keep the cylinders *l* and *g* upward and to lift the pawls *g g'* and *m m'*. This machine, thus fitted, is to be used as follows:

The articles to be pressed or reduced are to be placed between the follower or platen *D* and the lintel *C*. In this situation the levers *v* and *u* are to be placed across the smaller foot-flanges of the cylinders *l* and *g*, as shown in the detached Fig. 3, and the lever *w* is to be forced downward by any competent power. This will draw the joints connecting the pitmen 1 2 3 4 on the flanges *c c* nearly into a vertical line by forcing the pitmen 1 2 3 4 inward to the center of the machine, and thereby bringing the toggle-joint arms *d d' d'' d'''* into straight lines will lift the bed *K* and the short lifting-cylinder *g* and links 9 10, holding in the pawls *m m'*. The teeth of these, working into the teeth *a a* on each side of the vertical shaft *E*, rise with the bed *K* and force the shaft upward and with it the follower *D*. By an intermittent motion of one or two teeth, in space, at each descent of the lever *u* in this motion, the pawls *g g'* on *H*, allow the teeth *a* to slip past them in the upward motion, and then closing in retain all that the pawls *m m'* have gained. On reversing the motion of the lever *w* the bed *K*, cylinder *g*, and pawls *m m'* descend, the teeth on the pawls slipping down past the teeth *a*, and the toggle-arms spreading at the joint, and taking the position shown in the drawings, Fig. 1, and by following these motions the space between the follower *D* and lintel *C* will be decreased and any article within that space be compressed accordingly.

By placing the lever *v*, as shown in Fig. 2, across the machine, the cylinder *g'* is lifted by the spring *t* and is disconnected from the lifting-bed *K*, and on lifting the bed *K* the links 9 10 do not allow the pawls to fall in contact or onto the shaft *E* as the bed *K* rises, but only do so at the end of the motion, thus having no influence on the shaft *E*, that remains unlifted. The lever *u* remaining in action

on the smaller foot-flange of the cylinder *l*, the spring *s* cannot lift either that cylinder or the pawls *g g'*. In this situation the power applied on the lever *w* becomes inoperative, and the follower *D* remains stationary. By removing both the levers *v* and *w* to the situation shown in the drawings, Fig. 2, the operations are reversed, and the platen descends in the following manner: The cylinder *g'* being detached from the lever *v* and bed *K*, the spring *t* forces the cylinder *g* upward, so that the lower ends of the slots in the links 9 10 sustain the pawls *m m'* clear of the shaft *E*. In this situation, on the descent of the lever *w*, lifting the bed *K*, the spring *s* forces the cylinder *l* to follow it, lifting the pawls *g g'* by the links 5 6, and disengaging the pawls from the shaft *E* at the same time that the lifting-bed *K*, ascending without removing the now detached cylinder *g*, has raised the pawls *m m'* so much that the links 9 10 do not support them, and the pawls fall into gear with the teeth *a a* and support the shaft *E* in place of the pawls *g g'*. On reversing the motion of the lever *u* the descent of the bed *K* forces the cylinder *l* downward with it, and the slots in the links 5 6 cease to support the pawls *g g'*, so that these fall into gear with the teeth *a a* at the same time that the lower ends of the slots in the links 9 10 take the pins 11 12 and lift the pawls *m m'* out of gear with the teeth *a a*, and by continuing these motions the descent of the platen *D* will be effected and controlled as desired.

I do not claim to have invented any one of the parts herein described, nor do I claim to have invented, or to have in any way originally employed, any of the parts or arrangements covered or protected by the herein referred to patent and improvements of the said George Kilburn, my claims for improvements being hereby limited as follows:

1. The mode described and shown of governing the motions of the vertical bar *E* and follower *D* by the applying or withdrawing the action of the levers *v* and *u* on the foot-flanges *k* and *p* of the cylinders *l* and *g*, and the combination with these parts of the springs *s* and *t* and slotted lines 5 and 6 and 9 and 10, to operate by the pins 7 and 8 and 11 and 12 on the two pairs of pawls, so as that the bar *E* and follower *D* are sustained, raised or lowered, substantially in the manner and with the effects described.

2. The mode described of adjusting and timing the motions of the machine by the rod *r* and nuts 13 14 operating on the cylinder *g*, substantially as described and shown.

In witness whereof I have hereunto set my hand and seal, in the city of New York, this 27th day of November, 1843, in the presence of the witnesses subscribing hereto.

SMITH. CRAM. [L. S.]

Witnesses:

JOSEPH FRANCIS,
W. SERRELL.