



(19) **United States**

(12) **Patent Application Publication**
CONSTANS et al.

(10) **Pub. No.: US 2017/0305571 A1**

(43) **Pub. Date: Oct. 26, 2017**

(54) **HUMAN MACHINE INTERFACE FOR
DISPLAYING INFORMATION RELATIVE TO
THE ENERGY OF AN AIRCRAFT**

(57) **ABSTRACT**

(71) Applicant: **Airbus Operations (S.A.S.)**, Toulouse (FR)

(72) Inventors: **Florian CONSTANS**, Pibrac (FR);
Mathieu DEROO, Tournefeuille (FR);
Benjamin MAZOIN, L'Union (FR)

(21) Appl. No.: **15/137,891**

(22) Filed: **Apr. 25, 2016**

Publication Classification

(51) **Int. Cl.**

B64D 43/00 (2006.01)

B64D 31/06 (2006.01)

B64D 31/04 (2006.01)

(52) **U.S. Cl.**

CPC **B64D 43/00** (2013.01); **B64D 31/04**
(2013.01); **B64D 31/06** (2013.01)

A human machine interface linked to the throttle lever of an aircraft used to control the energy of an aircraft is disclosed. The HMI has upper part, which corresponds to the forward stroke of the lever, and a lower part, which corresponds to the rearward stroke of the lever. An upper shutter is positioned over the upper part, and a lower shutter is positioned over the lower part. A "cursor" acts as a visual representation in the HMI of the lever and its handle. The cursor moves forward or backward as the pilot acts on the lever/handle. The cursor indicates an ordered release of more or less aircraft energy, depending on its position on the display. The upper and lower shutters also indicate the ordered release of more or less aircraft energy, depending on the respective lengths of the two shutters. The HMI also includes a column in the display having a length symbolizing a current value in actual aircraft push or braking, depending on whether an aircraft push or braking has been ordered by releasing of more or less aircraft energy. The column changes in length as the actual aircraft push or braking changes. The cursor is further depicted in the HMI display as containing a memorizing button on the handle and a Go-Lever button on the lever below the handle.

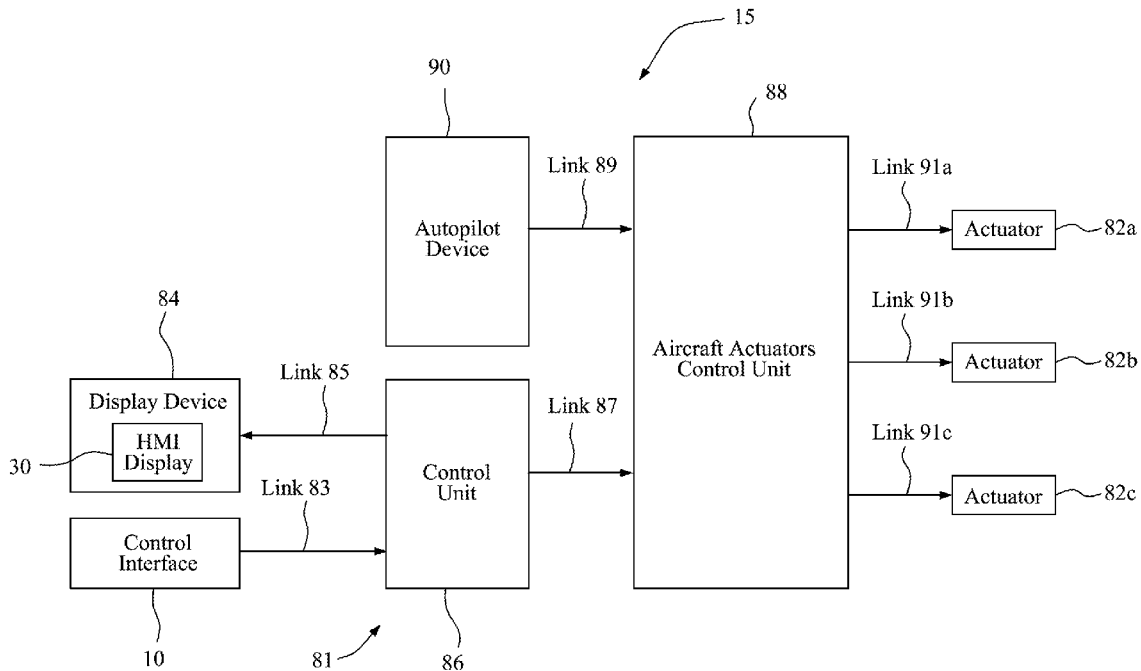

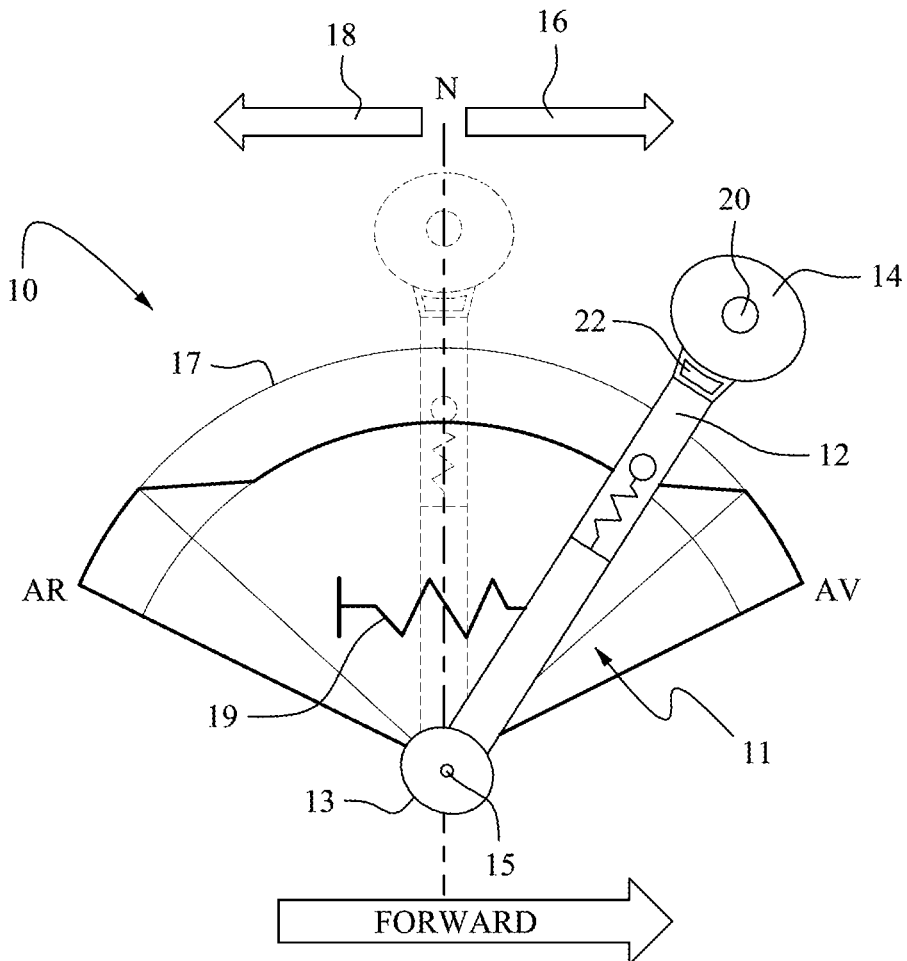

FIG. 1

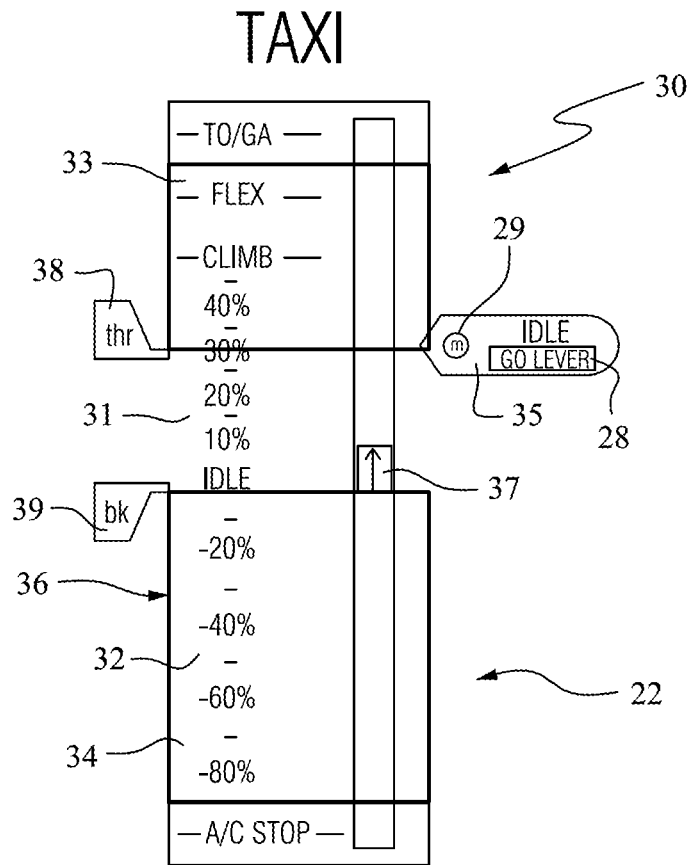

FIG. 2

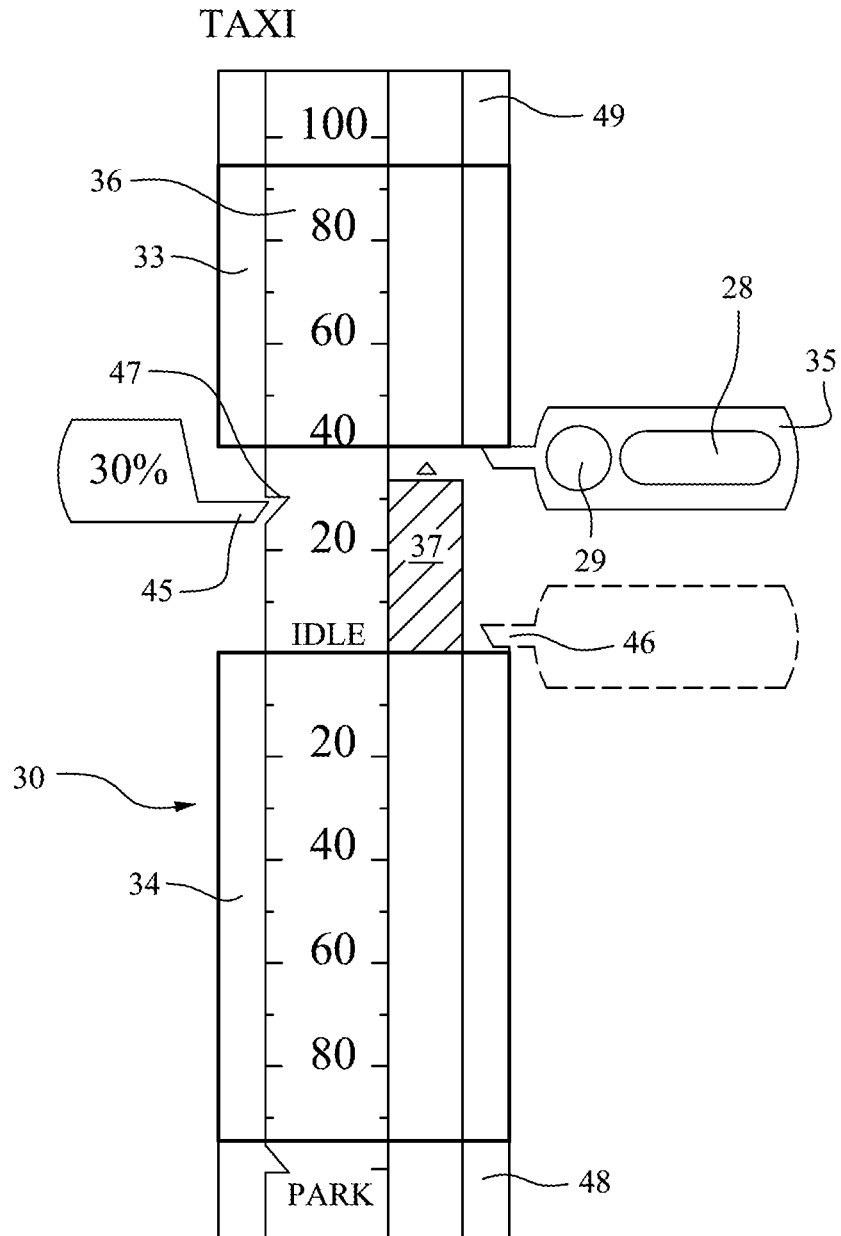

FIG. 3

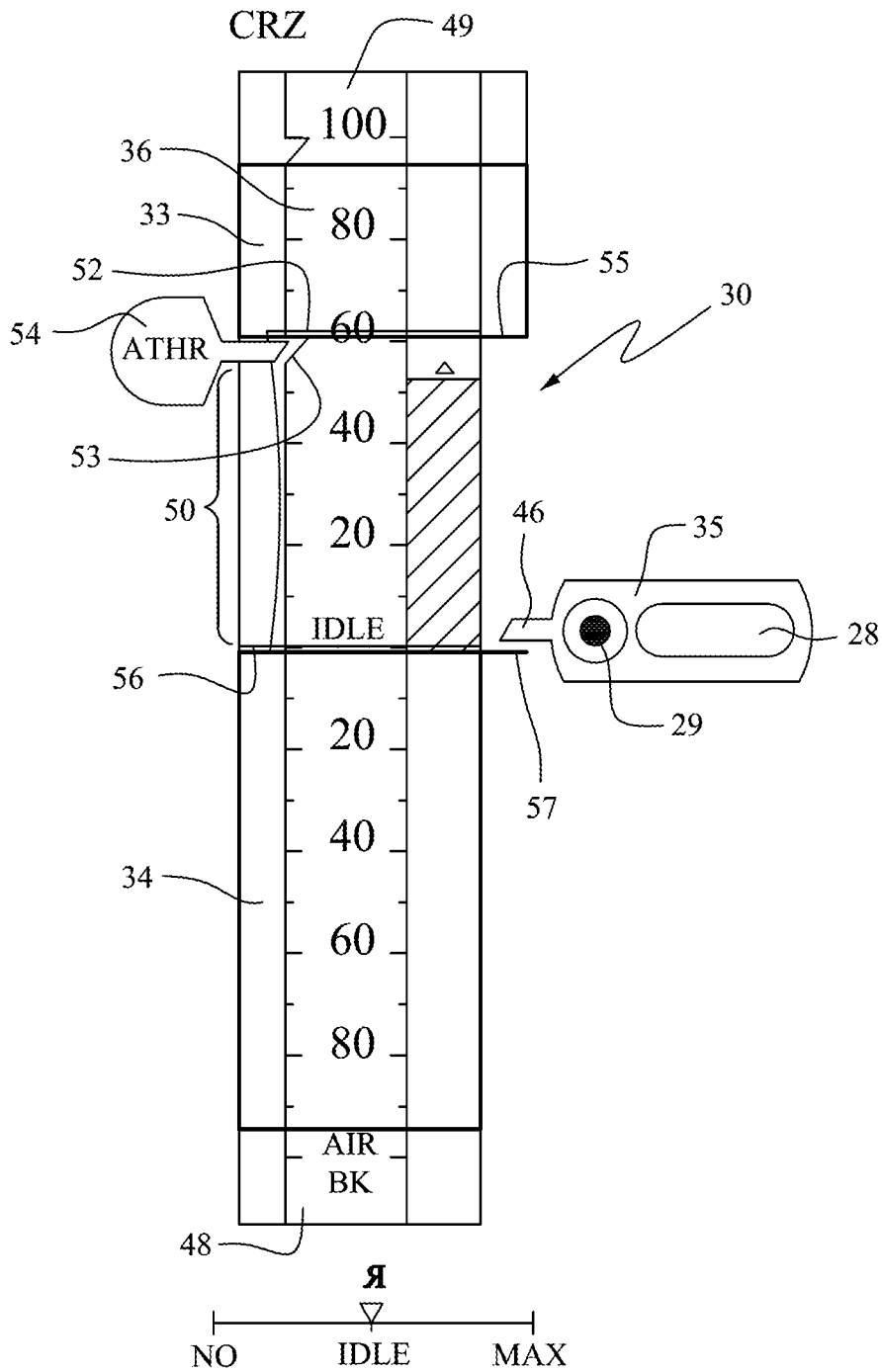

FIG. 4

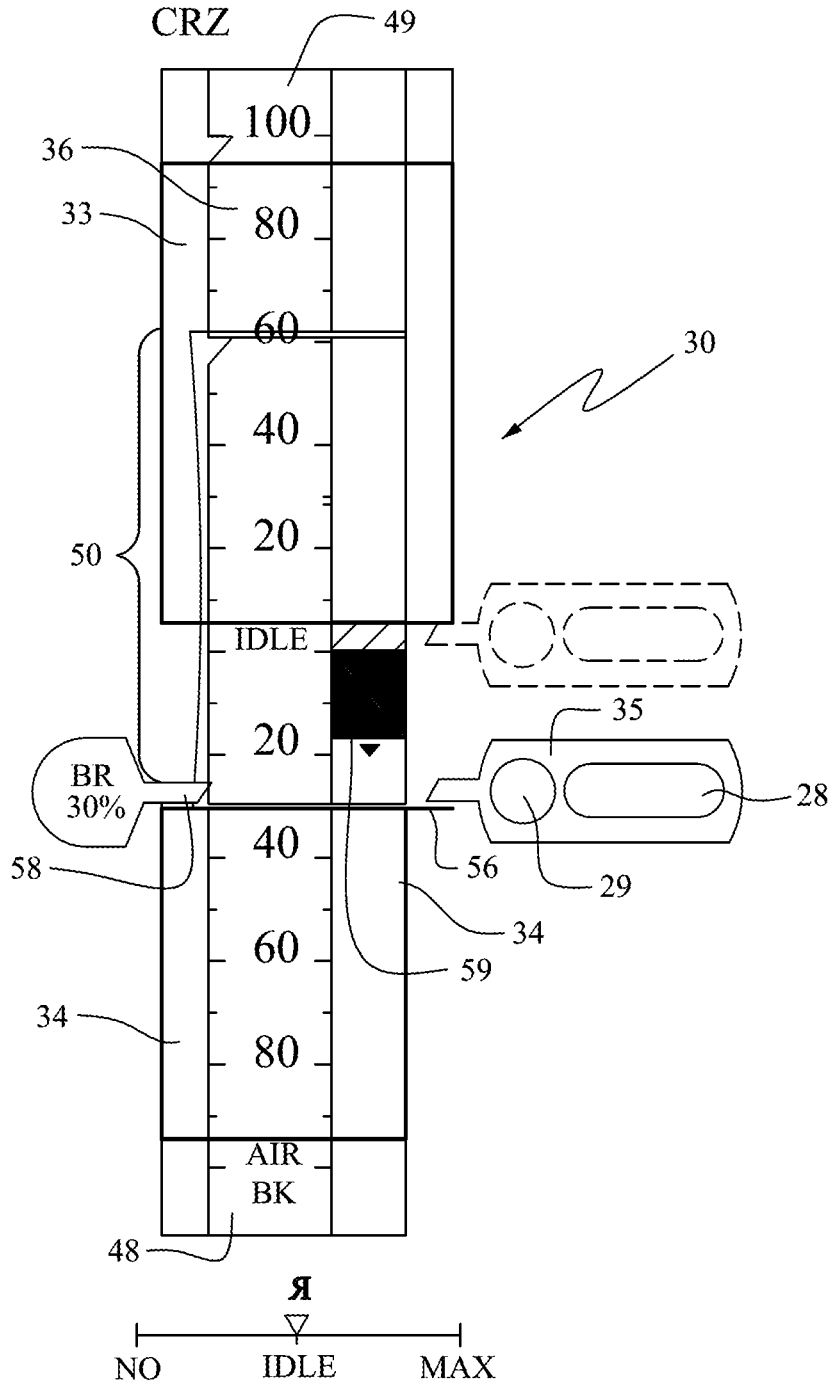

FIG. 5

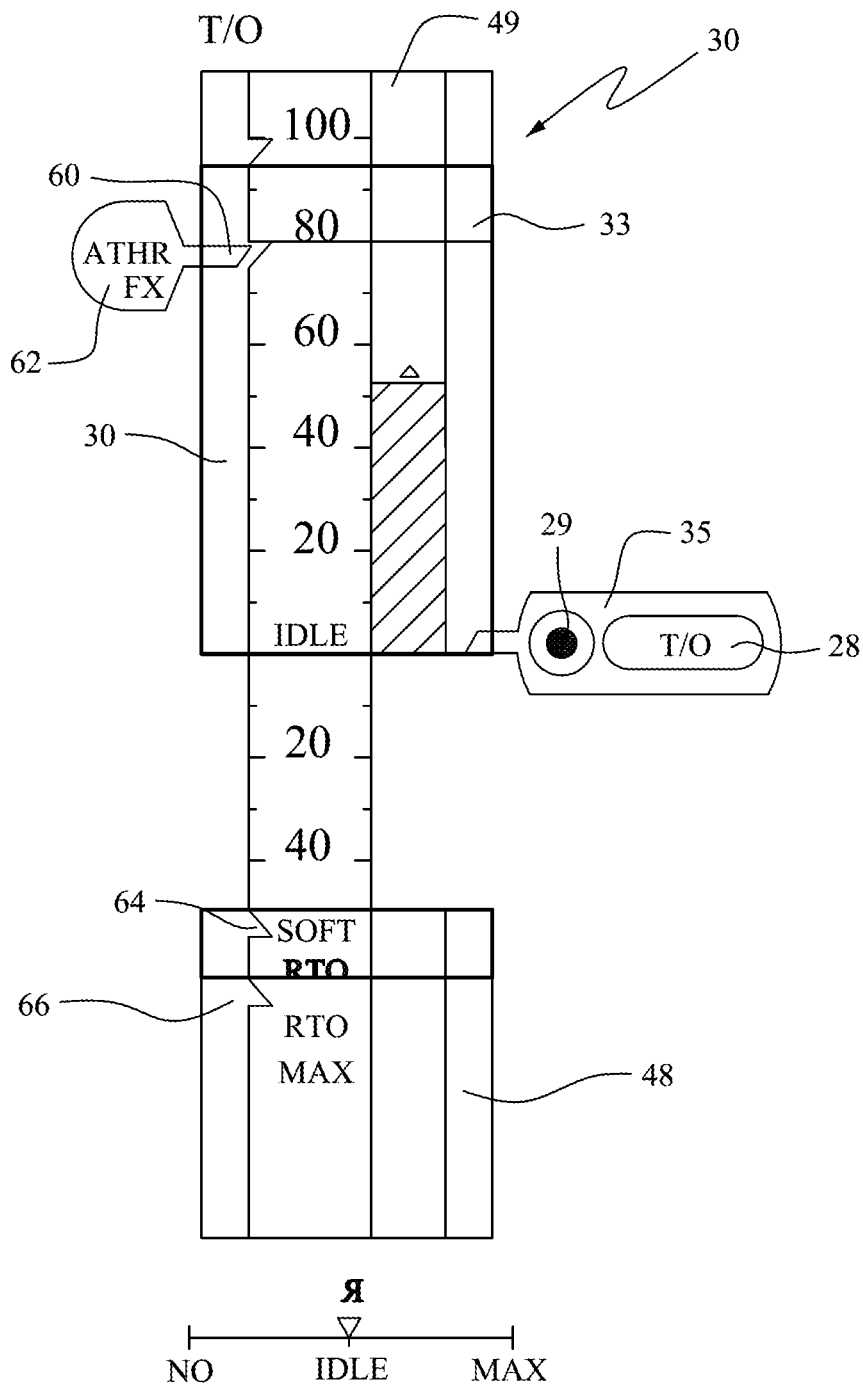

FIG. 6

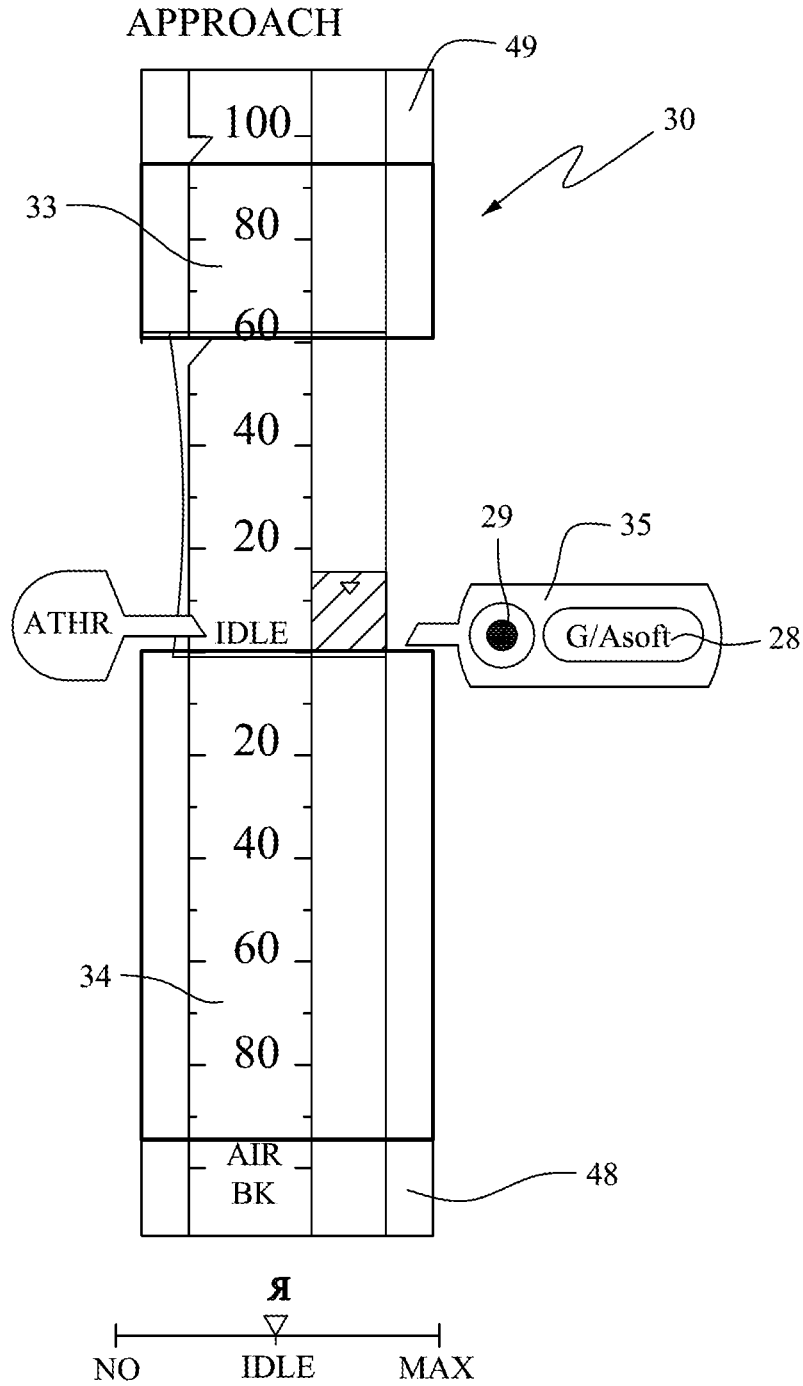

FIG. 7

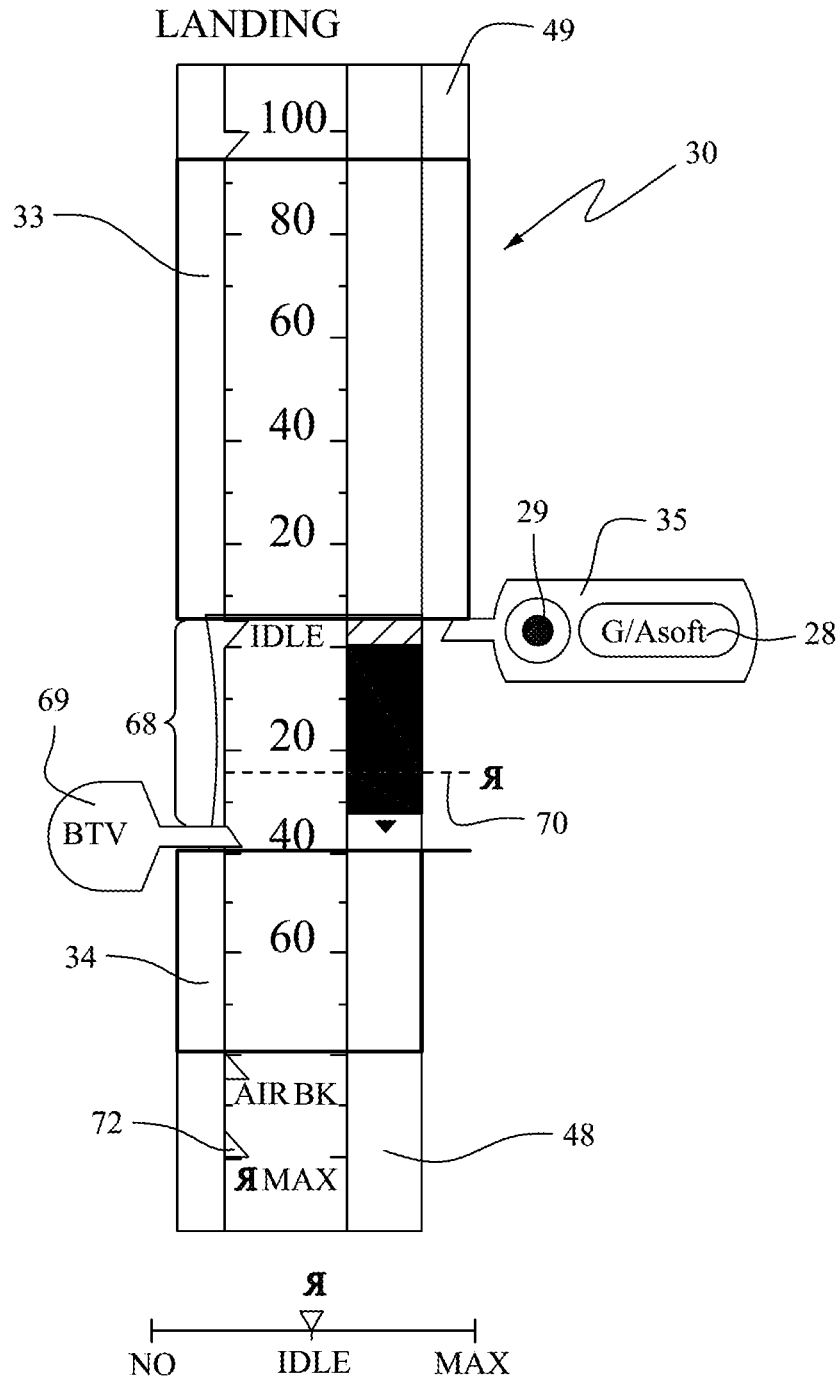

FIG. 8

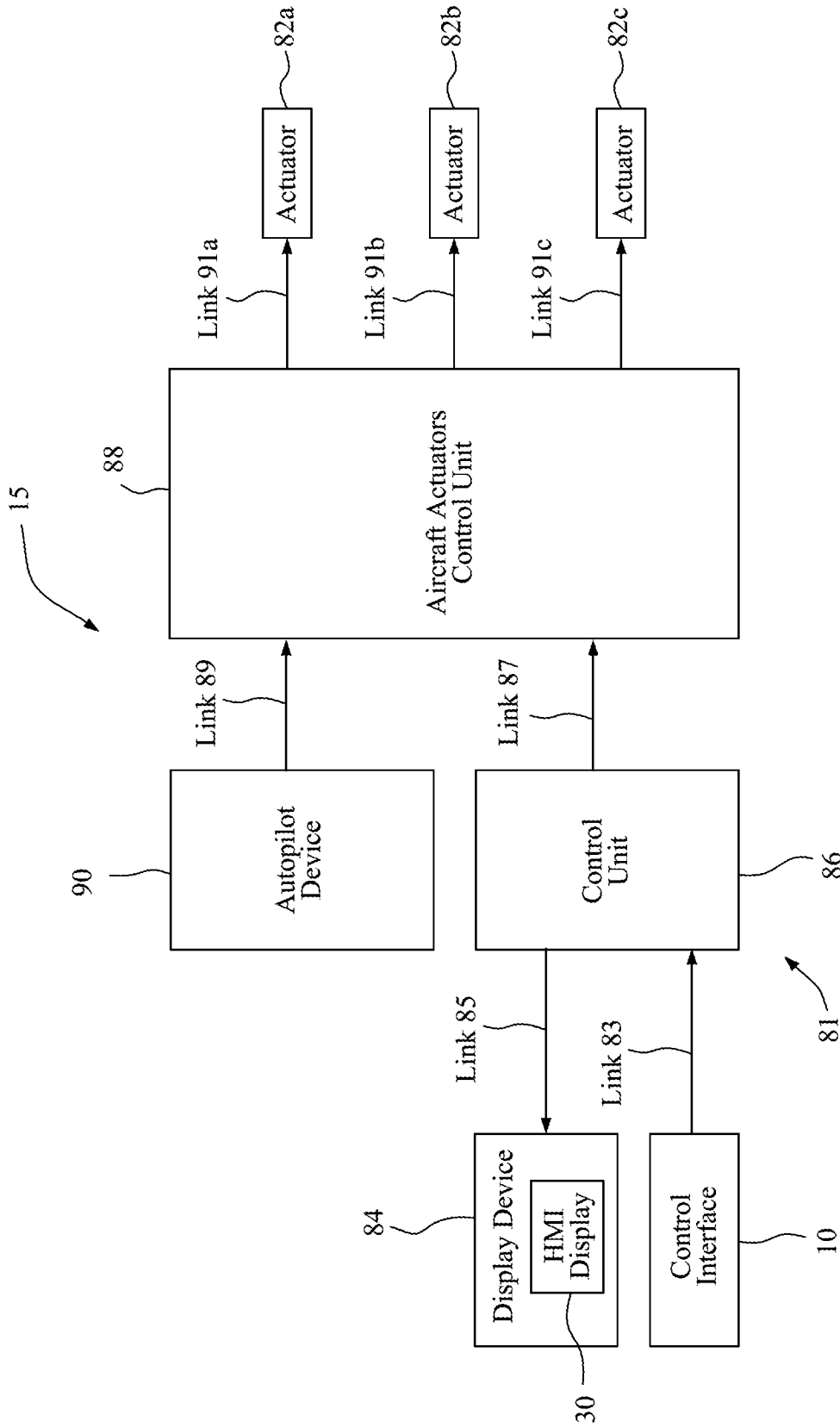

FIG. 9

HUMAN MACHINE INTERFACE FOR DISPLAYING INFORMATION RELATIVE TO THE ENERGY OF AN AIRCRAFT

[0001] The present invention relates to a system for controlling an aircraft, and more particularly to a human machine interface linked to the throttle lever of an aircraft used to control the aircraft.

BACKGROUND OF THE INVENTION

[0002] Today, aircraft typically include a flight control system which allows automatic control of the aircraft for improved aircraft handling. In this regard, flight control systems generally seek to achieve control of an aircraft's velocity, attitude and position by controlling the aircraft aerodynamic control surfaces and/or the thrust provided by the aircraft's engines. Flight control systems typically include flight, navigation, engine and system displays for pilot information, control devices for pilot interaction, computer systems for flight management and control, including flight guidance using autopilot (AP) and autothrottle (ATHR), sensors for measuring aircraft states, and actuators for executing commands. Typically, a flight control system allows a pilot to fly an aircraft in a manual mode, where the pilot uses a stick or yoke and pedals to control the aircraft, in a managed mode, where a pre-programmed flight plan is used to control the aircraft, and in an automatic mode, where a flight control unit controls the aircraft, and in which the autopilot/autothrottle calculates control signals which are executed by the flight control unit.

[0003] One of a pilot's tasks is to monitor and control the energy level of an aircraft to maintain the aircraft at an appropriate energy level throughout the flight phase to keep the aircraft's flight path, speed, thrust and configuration, or to recover the aircraft from a low energy or high energy situation, i.e., from being too slow and/or too low, or being too fast and/or too high. The level of energy that an aircraft has is a function of various flight parameters and their rate of change, including airspeed and speed trend, altitude and vertical speed (or flight path angle), aircraft configuration (i.e., drag caused by speed brakes, slats/flaps and/or landing gear), and thrust level. Controlling the aircraft energy level requires continuously controlling the flight controls. Autopilot and flight director modes, aircraft instruments, warnings and protections are designed to assist the pilot in controlling an aircraft's energy level.

[0004] The phrase "energy of an aircraft" is understood herein to mean the total energy of an aircraft, i.e., the sum of the kinetic energy and the potential energy of an aircraft. The principal devices for controlling and modulating the energy of an aircraft are the aircraft's engines (push and pull back), controlling aircraft surfaces, such as the air-brakes (spoilers), and the aircraft's wheel brakes (for ground phases). The solution provided by the present invention relates to all phases of the operation of an aircraft, i.e., on the ground (i.e., taxiing, takeoff and landing) and in flight (i.e., climbing, cruising, descending and approaching landing). Information related to the control of an aircraft's kinetic energy is typically distributed in the aircraft cockpit in the following way: (i) a throttle lever for controlling engine thrust; (ii) a lever for deploying the air-brakes or any element for controlling the drag on an aircraft; (iii) a lever for controlling an aircraft's wheel brakes; (iv) levers for thrust reversers for each engine; (v) switches and/or buttons

for selecting various push modes; and (vi) switches and/or buttons for the activation of the ATHR (i.e., the autothrottle for aircraft thrust).

[0005] U.S. Patent Application Publication No. US 2014/0346280, the entire contents of which is incorporated herein by reference, discloses a system for controlling an aircraft control parameter, such as one which is a function of aircraft energy. The system includes a control interface with a mobile element configured to move on a travel, of which at least two portions are separated by a neutral position, a return element for returning the mobile element back to the neutral position when it is not actuated, an interaction element, and a control unit configured to memorize an item of information corresponding to a first position of the mobile element at an instant of activation of the interaction element. The control unit is also configured to generate a set point of the aircraft control parameter, as a function of a control associated with the first position of the mobile element for which the information has been memorized, or a current position of the mobile element, when this current position is situated on the same portion of travel as the first position and is more remote than the latter from the neutral position.

BRIEF SUMMARY OF THE INVENTION

[0006] The present invention relates to controlling the energy of an aircraft, and more particularly to a human machine interface (HMI) linked to the throttle lever of an aircraft used to control the energy of an aircraft. The HMI is divided into two parts, that is, a first or upper part, which corresponds to the forward stroke of the lever, and a second, or lower part, which corresponds to the rearward stroke of the lever. Two shutters are placed on the two parts, that is, a first or upper shutter positioned over the first or upper part, and a second or lower shutter positioned over the second or lower part. Alongside the two shutters is a "cursor", which is a visual representation in the HMI of the lever/handle on which the pilot acts to control an aircraft. The cursor moves forward or backward as the pilot acts on the lever/handle. The HMI also includes a scale, which is a numerical percentage indication of a release of more or less aircraft energy. The cursor indicates an ordered release of more or less aircraft energy, depending on its position on the scale. The upper and lower shutters also indicate the ordered release of more or less aircraft energy, depending on the respective lengths of the two shutters. The lengths of the two shutters on the scale are determined by the positions of the ends of such shutters on the scale, which, in turn, can be delineated by two flag like indicators, respectively, bearing the acronyms "THR" for throttle and "BK" for brake. The HMI also includes a column in the display having a length or height symbolizing a current value in actual aircraft thrust or braking, depending on whether an aircraft push or braking has been ordered by the releasing of more or less aircraft energy. The column changes in length or height as the actual aircraft thrust or braking changes, and the length of the upper shutter or the lower shutter changes in response to the ordered value in an increase or a decrease in the energy of the aircraft. Finally, the cursor is further depicted in the HMI display as containing representations of switches depicted as a memorizing button on the handle and the memorizing button's activation position and as a Go-Lever button on the lever below the handle and the Go-Lever button's activation position.

BRIEF DESCRIPTION OF THE DRAWINGS

[0007] FIG. 1 is an exemplary embodiment of a control interface which is part of a system for controlling the energy of an aircraft.

[0008] FIG. 2 generally depicts the HMI of the present application.

[0009] FIG. 3 depicts the HMI of the present application in manual mode.

[0010] FIG. 4 depicts the HMI of the present application with the automatic mode (ATHR) activated.

[0011] FIG. 5 depicts the HMI of the present application with the exit of the air-brakes mode activated.

[0012] FIG. 6 depicts the HMI of the present application in phase of RTO.

[0013] FIG. 7 depicts the HMI of the present application in phase of approach.

[0014] FIG. 8 depicts the HMI of the present application at the time of the exit of the reverses.

[0015] FIG. 9 is a simplified schematic of a system for controlling the control interface used to control the energy of an aircraft.

DETAILED DESCRIPTION OF THE INVENTION

[0016] FIG. 1 depicts an exemplary embodiment of a control interface 10 which is part of a system for controlling the energy of an aircraft. The control interface 10 is similar to the control interface disclosed in U.S. Application Publication No. US 2014/0346280. The control interface 10 includes a mobile element 11 including a lever 12 equipped at its free end with a handle 14. Another end 13 of the lever 12 is rotatable around an axis 15 orthogonal to the plane of FIG. 1. This rotation enables movement by the handle 12 along a travel 17 between an extreme reverse position (AR) and an extreme forward position (AV). Thus, the handle 12 has two directions of travel, i.e., forward 16 and backward 18, which are separated by a neutral position N. An element 19, such as a spring, urges the handle 12 to return to the neutral position N when the pilot is no longer holding the handle 12, so that the handle 12 is not being actuated.

[0017] The handle 12 shown in FIG. 1 has several functional modes of operation, i.e., a manual operation mode, an automatic operation mode, a memorizing function mode and a release of operations mode.

[0018] The manual operation mode is mainly used when an airplane is taxiing on the ground because the pilot must be able to make the airplane accelerate (lever forward) or decelerate (lever backward) when the plane is taxiing. Thus, when the pilot wishes to increase the aircraft energy so as to accelerate the airplane, he can initiate a thrust order by displacing the lever 12 in the forward travel direction 16, with which a control of the aircraft's engine thrust is associated. When the pilot wishes to decrease the aircraft energy so as to decelerate the aircraft, he can initiate a braking of the aircraft by displacing the lever 12 in the reverse travel direction 18, with which is associated a control of the aircraft's wheel brakes and/or airbrakes when the aircraft is on the ground. When the aircraft is in flight, this control corresponds to a control of the aircraft's air-brakes.

[0019] In the automatic operation mode, a pushing monitoring system manages the push in a pre-allocated range of authority. The pilot can increase this range forwards by

forcing a maximum push called TOGA (for Take-Off/Go-Around thrust) or increase the range of authority backwards (authorization to deploy the air-brakes).

[0020] The function for the release of operations makes it possible to activate certain specific operations during flight (activation of takeoff, activation of a go-around, etc.). The interface for this is a "Go-Lever" button 22 which is arranged on the lever 12 just below the handle 14 for triggering the TO/GA functions corresponding to the maximum thrust of the aircraft engines associated with the activation of certain specific aircraft operations during flight, such as the activation of takeoff or the activation of a go-around, which may occur on an approach to land.

[0021] The memorizing function makes it possible to memorize a particular position of the handle. The lever 12 also includes a memorization button 20 arranged on the handle 14 of the lever 12 for holding thrust or deceleration settings. Once a storage interface is activated, the order to push, drag (spoiler) or brake using corresponding wheel brakes is stored by the flight control system and continues to be applied even if the handle 14 and lever 12 are then released by the pilot.

[0022] The present invention is directed to an extension of the foregoing functions through the use of a human machine interface (HMI) which is coupled with the lever 12 and handle 14 shown in FIG. 1, and which integrates the various methods for controlling the energy of the aircraft, i.e., (i) engine thrust (all of the engines), (ii) the aerodynamic braking surface for generating drag: e.g., air-brakes (spoilers) or any other element, (iii) the braking carried out by the brakes available on the aircraft landing gear, and (iv) thrust reversers for each engine, with a single lever and handle, like the lever 12/handle 14 shown in FIG. 1. The presentation of all of the information concerning the control of aircraft energy is currently not adapted to the concept of a unique handle, like the lever 12/handle 14 shown in FIG. 1, since this does not correspond to the global concept of this kind of handle. Indeed, the objective of the present invention is to make transparent to the pilot all the means of controlling aircraft energy by providing a single HMI that performs this function.

[0023] The HMI described herein consists of a display for transmitting to a pilot the information relevant to controlling aircraft energy, either through visual or haptic (sense of touch) feedback. This control is done either manually or automatically via an automatic control (i.e., the autothrottle ATHR). The following information is provided visually by the HMI to make the device suitable for representing the physical device in the interface. This information includes:

[0024] The presentation of the maximum limits (acceleration) and minimum limits (in deceleration) of the lever race.

[0025] The representation of the position of the handle within these acceleration and deceleration limits.

[0026] The representation of associated buttons, including: (1) a memory button: (i) of a push/deceleration ordered value (in manual), and (ii) of a range of authority (in ATHR); (2) and a Go-Lever which enables automatic triggering of a flight phase change, including: (i) takeoff when the plane is aligned, and (ii) go-around in an approach phase.

[0027] The representation of the current value of: (1) forward (thrust), and (2) backward (deceleration or braking).

[0028] The representation of the controlled value, including: (1) for the pilot (manual mode): (i) forward (thrust), and

(ii) backward (deceleration or braking); (2) for automation (ATHR): (i) forward (thrust), and (ii) backward (deceleration or braking).

[0029] The representation of the range of authority allocated to the control system: (1) forward the front (maximum thrust), and (2) backward (maximum deceleration).

[0030] Related information, including: (1) activated modes (Flex, Climb, TOGA, Auto-delay Brake To Vacate): (i) TOGA: automatic mode of application of the maximum thrust (TOGA thrust); (ii) Flex automatic mode using a reduced thrust during takeoff or during go-around compared to the maximum thrust (TOGA); (iii) Climb: automatic mode using a reduced thrust for the climbing phase compared to the maximum thrust (TOGA); (iv) Self-delay: Automatic mode to reduce the thrust toward the IDLE level during the flare-out phase on landing; (v) Brake-To-Vacate (BTV): automatic braking mode to reach an exit ramp at an adequate speed while optimizing runway occupation time and brake wear; (vi) Max rejected takeoff (RTO) braking mode using all the aircraft's braking capacity following cancellation of take-off; and (vii) (Soft RTO: optimized braking mode following the take-off cancellation (no systematic application of full deceleration, if conditions allow).

[0031] (2) Some specific information is transmitted to the pilot haptically: (i) the presentation of the maximum limits (acceleration) and minimum limits (deceleration) of the handle race; (ii) the representation of the position of the handle in these limits; (iii) the representation of the activation position memorization button; and (iv) the representation of the activation position of the "Go-Lever" button.

[0032] To display all of the foregoing information, the HMI of the present invention is dedicated to the lever/handle used by the pilot to control the aircraft. For the HMI to be effective, it addresses the lack of homogeneity between the gesture to perform and visual feedbacks. To do so, it reproduces the elasticity effect associated with the functioning of the lever used by the pilot to control the aircraft. This results in a preferred HMI in which: (i) the HMI is vertically presented; (ii) the kinetic energy of an aircraft is integrally presented; and (iii) the physics associated with a return to the neutral position of the lever as soon as the pilot releases the lever are reproduced in the display.

[0033] A preferred, vertical embodiment of a human machine interface (HMI) display **30** according to the present invention is shown in FIG. 2. The display can be, by way of example, a tactile pad external to the cockpit screens, or a display screen of the cockpit. The display can also be interactive (touch activated functions) or passive, or both. The interface **30** is divided into two parts: (1) a first or upper part **31**, which corresponds to the forward stroke of the lever **12**, and (2) a second, or lower part **32**, which corresponds to the rearward stroke of the lever **12**. Two "shutters" are placed on the two parts, that is, a first or upper shutter **33** positioned over the upper part **31**, and a second or lower shutter **34** positioned over the lower part **32**. The shutters **33** and **34** are shown in FIG. 2 as square or rectangular shapes delineated using bold black lines. However, in an actual HMI display, the shutters can be "highlighted" through the use of different colors or different shades of a color for the shutters **33** and **34** versus the portions of the upper and lower parts **31** and **32** of the display **30** not covered by the shutters.

[0034] Alongside the two shutters is a "cursor" **35**, which is a visual representation in the interface **30** of the lever/handle **12** on which the pilot acts to control an aircraft: The

cursor **35** moves forward or backward as the pilot acts on the lever/handle **14**. The interface display also includes a scale, which is a numerical percentage or other relative or absolute indication of a release of more or less aircraft energy. The cursor **35** indicates an ordered release of more or less aircraft energy, depending on its position on the scale **36**. The upper and lower shutters **33** and **34** also indicate the ordered release of more or less aircraft energy, depending on the respective lengths of the two shutters. The lengths of the two shutters on the scale **36** are determined by the positions of the ends of such shutters on the scale **36**, which, in turn, can be delineated by two flag like indicators **38** and **39**, respectively, bearing the acronyms "THR" for throttle and "BK" for brake in FIG. 2.

[0035] The shutters **33** and **34** used in the interface display **30** can be analogized to the principle of a water lock, wherein, depending on the extent the door of the water lock is opened, more or less water escapes from the lock. In this analogy, the aircraft energy is associated with the current of the escaping water. The commanded value for increasing or decreasing aircraft energy is represented by one of the shutters **33** and **34**, which are symbolized by the door of the lock, which can be raised or lowered.

[0036] The interface **30** also includes a column **37** having a length or height symbolizing a current value in actual aircraft push or braking, depending on whether an aircraft push or braking has been ordered. The column **37** changes in length or height and direction as the actual aircraft push or braking changes, and the length of either the upper shutter **33** or the lower shutter **34** changes in response to the ordered value in the increase or decrease in the energy of the aircraft. Finally, the cursor **35** is further depicted in the interface display **30** as containing representations of a memorizing button **29** corresponding to the actual memorizing button **14** on the handle **14** and the memorizing button's activation position (i.e., ON or OFF) and a Go-Lever button **28** corresponding to the actual memorizing button **22** on the lever **12** below the handle **14** and the Go-Lever button's activation position (i.e., ON or OFF).

[0037] FIG. 9 is a simplified schematic of a system **81** for controlling the control interface **10** shown in FIG. 1 of this application, which is used to control the energy of an aircraft. The system is similar to the system **1** for controlling an aircraft control parameter depicted in FIG. 1 of U.S. Patent Application Publication No. US 2014/0346280. The system **81** includes a control unit **86** and a display device **84**, which includes the HMI display **30**. The control interface **10** is linked to the control unit **86** by a link **83** and the control unit **86** is linked to the display device **84** by a link **85**. An aircraft autopilot device **90** and the control system **81** are linked to a unit **88** for controlling aircraft actuators by respective links **89** and **87**. The actuator control unit **88** controls a set of actuators **82a**, **82b**, **82c** by links **91a**, **91b** and **91c**, respectively, for various aircraft functions, including flight control. The actuators may be electrical, hydraulic and/or pneumatic in nature.

[0038] FIG. 3 depicts the HMI display **30** of the present invention in manual mode. In FIG. 3, the shutters **33** and **34** represent the ordered values of the release of more or less aircraft energy, and the column **37** represents the actual push **45** provided by the aircraft engines. The lever/handle **14** is symbolized by the cursor **35** containing the two buttons, that is, the memorizing button **29** and the Go-lever button **28**.

[0039] The symbolized lever or cursor **35** follows the stroke of the lever **12**/handle **14** handled by the pilot. This following is achieved using sensors on the actual handle **12** which are feed into the control unit **86**, which is a computer, and which drives the display device **84**, and thus the interface display **30**. The control unit **86** is preferably a computer. With the “effect of gravity” (elasticity), when the pilot releases the lever **12**/handle **14**, the symbolized lever/handle depicted as cursor **35** and the shutter **33** fall down towards the neutral or IDLE position **46**, unless the memorization button **29** was pressed so as to have left a mark **47** on the scale **36**. In this case, the cursor **35** falls down to the neutral position **46** from the memorization position **45**, but the shutter **33** remains “blocked” by the memorization mark **47**.

[0040] At the two ends of the main shutters **33** and **34**, two small “shutters” **48** and **49**, which indicate the extreme values that will be automatically memorized when the position of the cursor **35** reaches these values. The values which can be memorized automatically correspond to automatic modes suggested according to the conditions of rolling or flying, depending on the situation of an aircraft. The small shutters **48** and **49** are shown in FIGS. 2-9 as square or rectangular shapes, which are not delineated using bold black lines so as to distinguish them from the main shutters **33** and **34**. Here again, in an actual HMI display, the shutters **48** and **49** can be “highlighted” through the use of different colors from the colors used for the shutters **33** and **34** or different shades of a color used for all of the shutters **33**, **34**, **48** and **49** versus the portions of the upper and lower parts **31** and **32** of the display **30** not covered by any of these shutters.

[0041] In the automatic mode (ATHR) of operation, after takeoff, which is detected by the use of the Go-Lever button while the aircraft is still on the ground, a range indicator **50** appears automatically in the interface display **30**, as shown in FIG. 4. The range **50** includes an upper bar **55** and a lower bar **56**, which corresponds to where the value **52** ordered by the ATHR is located. A mark **53** is also added to the scale **36** in the upper part **33** of the display **30**, which symbolizes the ordered value **52** in the increase in the energy of the aircraft, with the mark serving to block the upper shutter when the lever **12** is released and the cursor **35** returns to the neutral position **46**. The display **30** also includes a flag-like symbol **54** with the acronym ATHR indicating the value in the increase in the energy of the aircraft ordered by the automatic mode. The lower shutter **34** is then reduced in width in the interface display **30**, so that it becomes impossible for the cursor **35** move down into the lower part **34** of the display **30** to thereby order an air-brake value corresponding to a reduction in aircraft energy.

[0042] As shown in FIG. 5, when the state of the memorization button **29** appears “hollow”, this confirms the impossibility of engaging it. If the push/increase in aircraft energy ordered by the automatic mode (ATHR) goes back to the IDLE, as evidenced by the cursor **35** being at the IDLE position **46**, as shown in FIG. 4, the memorization button **29** appears “full”, as depicted by the black circle shown in the memorization button **29**. In addition, the lower bar **56** of the range **50** widens until the limit **57** of the interface **30**. This increase in the width of the lower bar **56** of the range **50** means that the pilot can increase the range **50** backwards into the lower part **34**, thus making it possible for the automatic push to order an air-brake value **58**, as shown in FIG. 5. The ordered value is shown as being 30% of the minimum in aircraft energy shown by shutter **48**, which includes the acronym AIR BK shown in FIG. 5 within shutter **48**. In this case, the aircraft energy is reduced with

some inertia as the actual value **59** of air-brake is increased, which actual value **59** is depicted by the black column shown FIG. 5.

[0043] Descriptions of particular cases of use of the HMI are described below.

[0044] Referring to FIG. 6, during the takeoff phase on the ground, the Go-Lever button **28** shown in the display **30** on cursor **35** is labeled with the acronym “T/O”. The pilot presses the “T/O” labeled button **22** on the lever **12** shown in FIG. 1. The automatic mode (ATHR) push appears with the value **60** corresponding to the automatic mode “FLEX”. The display **30** again includes a flag-like symbol **62** with the acronym ATHR FX located at the value in the increase in the energy of the aircraft ordered by the automatic mode ATHR FX. The higher shutter **33** is automatically placed at this ordered value **60**. The back shutters **48** and **49** change configurations; they present the positions to be reached to activate the rejected takeoff RTO “software” and the rejected takeoff RTO “MAX”. The notches **64** and **66** present the exact positions to activate the RTO “software” and the RTO “MAX”.

[0045] Referring to FIG. 7, during the approach phase, evidenced by the acronym APPROACH appearing at the top of display **30**, the oval button **28** inside the cursor **35**, which is the visual representation of the lever **12**, is labeled with the acronym G/A SOFT. By pressing the oval button **28**, the pilot engages a go-around.

[0046] Referring to FIG. 8, during the landing phase, the range **68** of the automatic mode (ATHR) push moves automatically backwards into the lower part **32**, in order to become a range of authority for automatic braking. The principle remains the same one as that describing the range of authority for a positive push, as shown in FIG. 4. If the automatic mode of braking BTV is engaged, label “ABK” (for AutoBrake) becomes “BTV” in flag label **69**. Depending on to the engaged mode (NO/IDLE/MAX), the thrust reversers are presented in the HMI in two different ways: (i) a highest rate of braking before using the thrust reversers, which appears in the form of a limit **70**, and (ii) a highest rate of deceleration of the plane using the brakes at a maximum and the thrust reversers, which appears in the form of a second limit **72**, placed in the second, lower shutter **48**.

[0047] While the invention has been described in connection with what is presently considered to be the most practical and preferred embodiment, it is to be understood that the invention is not to be limited to the disclosed embodiment, but on the contrary, is intended to cover various modifications and equivalent arrangements included within the spirit and scope of the appended claims.

What is claimed is:

1. An interface for displaying information relative to the energy of an aircraft, the interface being a display comprising:

- a cursor symbolizing and corresponding to a lever handled by a pilot to control the energy of the aircraft,
- a first part corresponding to a first direction in which the lever is moved to increase the energy of the aircraft,
- a second part corresponding to a second direction in which the lever is moved to decrease the energy of the aircraft,
- a neutral position located between the first and second parts,
- the cursor being movable so as to follow actual strokes of the lever to increase or decrease the energy of the aircraft, and to return to the neutral position in the race when the lever is not being handled,
- a first shutter positioned over the first part of the display which changes in length as the cursor moves in the first

- part of the display, the length of the first shutter symbolizing an ordered value in the increase in the energy of the aircraft,
- a second shutter positioned over the second part of the display which changes in length as the cursor moves in the second part of the display, the length of the second shutter symbolizing an ordered value in the decrease in the energy of the aircraft,
 - a first column having a length symbolizing a current value in actual aircraft push, the first column changing in length as the actual aircraft push changes and the length of the first shutter changes in response to the ordered value in the increase in the energy of the aircraft,
 - a second column having a length symbolizing a current value in actual aircraft braking, the second column changing in length as the actual aircraft braking changes and the length of the second shutter changes in response to the ordered value in the decrease in the energy of the aircraft, and
 - a plurality of switches, including one for memorizing a selected aircraft push or aircraft deceleration when the lever is operated in a manual mode, and for setting a range of authority when the lever is operated in an automatic mode, and one which enables automatic triggering of a flight phase change when the lever is operated in an automatic mode.
2. The interface according to claim 1, wherein the first part includes a first scale to provide measures of ordered and actual values in the increase in the energy of the aircraft, and wherein the second part includes a second scale to provide measures of ordered and actual values in the decrease in the energy of the aircraft.
3. The interface according to claim 2, wherein the first scale depicts ordered values in the increase in the energy of the aircraft and actual values of aircraft push as percentages of a maximum limit in aircraft energy, and wherein the second scale depicts ordered values in the decrease in the energy of the aircraft and actual values of aircraft braking as percentages of a minimum limit in aircraft energy.
4. The interface according to claim 3, wherein the display further comprises third and fourth shutters which indicate maximum and minimum limits in aircraft energy.
5. The interface according to claim 1, wherein the plurality of switches are a memorizing button on a handle at an end of the lever for initiating a memorizing function in which an ordered increase or decrease in the energy of the aircraft is memorized when the lever is operated in a manual mode, or the range of authority is set in which the energy of the aircraft can increase or decrease when the lever is operated in an automatic mode, and a Go-Lever button on the lever which enables the automatic triggering of the flight phase change when the lever is operated in the automatic mode, and wherein the memorizing button is depicted in an ON position when a memorizing function is activated.
6. The interface according to claim 5, wherein the interface display further comprises a mark that is added to the first or second part of the display which symbolizes the ordered increase or decrease, respectively, in the energy of the aircraft corresponding to the position of the lever when the lever is operated in the manual mode, the mark serving to block the first or second shutter, respectively, when the lever is released and the cursor return to the neutral position, and wherein the interface display further comprises a range indicator that is added to the first and/or second part of the display which symbolizes the range of authority in which the energy of the aircraft can increase or decrease, respectively, when the lever is operated in the automatic mode.
7. The interface according to claim 1, wherein the neutral position is identified on the display with an IDLE label.

8. The interface according to claim 6, wherein when a selected automatic mode (ATHR) of operation of the aircraft is selected, the memorizing button is depicted in an OFF position and the Go-Lever button is depicted as including an acronym associated with a mode of aircraft operation, wherein the range display is depicted with first and second bars added to the first or second part of the display with one bar at the neutral position and the other bar at the value ordered by the automatic mode in the increase or decrease, respectively, in the energy of the aircraft, and wherein the range display further includes a flag symbol indicating the value in the increase or decrease in the energy of the aircraft ordered by the automatic mode, and either a reduction in width of the second shutter to prevent the cursor from ordering a brake value where the automatic mode has ordered an increase in aircraft energy or of the first shutter to prevent the cursor from ordering a push value where the automatic mode has ordered a decrease in aircraft energy.

9. The interface according to claim 8, wherein when during a selected automatic mode of operation the cursor goes back to the neutral position, the memorizing button is depicted in an ON position, and the second bar of the range display widens until either a limit of the second shutter is reached where the cursor is positioned in the first part of the display so as to have ordered an increase in aircraft power, thereby making it possible for the pilot to extend the range of the automatic mode such that the second bar of the range is positioned in the second part of the display.

10. The interface according to claim 8, wherein when during takeoff the pilot presses a takeoff (T/O) button on the lever, the acronym depicted on the Go-Lever button is take off (T/O) and a symbol associated with an automatic push mode is displayed in the first part to indicate the value ordered by the automatic push mode to increase aircraft energy to a level corresponding to a mode "FLEX", the first shutter is reduced in length so as to be automatically placed at the value ordered by the automatic push mode, the second and fourth shutters are changed in length so as to be placed respectively at positions to be reached to activate RTO "software" and RTO "MAX" modes of operation, and notches are placed on the second part of the display to present exact positions for activation of the RTO "software" and RTO "MAX" modes of operation.

11. The interface according to claim 8, wherein the display includes a second acronym indicating a mode of operation of the aircraft when the lever is operated in automatic mode.

12. The interface according to claim 4, wherein all of the shutters are delineated in the interface display through the use of different colors for each of the shutters or different shades of a color for each of the shutters versus portions of the first and second parts of the display not covered by the shutters.

13. An human machine interface (HMI) for displaying information relative to the energy of an aircraft, the interface being a vertical display comprising:

- a cursor symbolizing a lever handled by a pilot to control the energy of the aircraft,
- a race including
 - an upper part corresponding to a forward direction in which the lever is moved to increase the energy of the aircraft,

- a lower part corresponding to a reverse direction in which the lever is moved to decrease the energy of the aircraft, and
- an idle position located between the upper and lower parts,
- the cursor being movable so as to follow actual strokes of the lever to increase or decrease the energy of the aircraft, and to return to the idle position in the race when the lever is not being handled,
- an upper shutter positioned over the upper part of the race which changes in length as the cursor moves in the upper part of the race, the length of the upper shutter symbolizing an ordered value in the increase in the energy of the aircraft,
- a lower shutter positioned over the lower part of the race which changes in length as the cursor moves in the lower part of the race, the length of the lower shutter symbolizing an ordered value in the decrease in the energy of the aircraft,
- an upper column having a height symbolizing a current value in actual aircraft push, the upper column changing in height as the actual aircraft push changes and the length of the upper shutter changes in response to the ordered value in the increase in the energy of the aircraft,
- a lower column having a height symbolizing a current value in actual aircraft braking, the lower column changing in height as the actual aircraft braking changes and the height of the lower shutter changes in response to the ordered value in the decrease in the energy of the aircraft, and
- a memory button for a selected aircraft push or aircraft deceleration when the lever is operated in a manual mode, and for a range of authority when the lever is operated in an automatic mode, and a Go-Lever button which enables automatic triggering of a flight phase change.

14. The HMI according to claim **13**, wherein the vertical display includes a scale to provide measures of ordered and actual values in the increase and decrease in the energy of the aircraft.

15. The HMI according to claim **14**, wherein the scale depicts ordered values in the increase and decrease in the energy of the aircraft and actual values of aircraft push as percentages of a maximum limit in aircraft energy, and actual values of aircraft braking as percentages of a minimum limit in aircraft energy.

16. The HMI according to claim **13**, wherein the display further comprises second upper and lower shutters which indicate respectively the maximum and minimum limits in aircraft energy.

17. A human machine interface (HMI) for displaying information relative to the energy of an aircraft, the interface being a display comprising:

- a depiction of a lever handled by a pilot to control the energy of the aircraft,
- a depiction of a race within which the lever moves as the lever handled by the pilot is moved,
- indications of a maximum limit of aircraft acceleration and of a minimum limit of aircraft deceleration of the race within which the lever moves,
- a depiction of a plurality of buttons, including (1) a memory button for (i) a selected aircraft push or aircraft deceleration when the lever is operated in a manual

- mode, and (ii) for a range of authority when the lever is operated in an automatic mode, and (2) and a Go Lever which enables automatic triggering of a flight phase change, including: (i) takeoff when the aircraft is aligned for doing so, and (ii) a go-around when the aircraft is in a landing approach phase,
- indications of a current, actual value of aircraft forward thrust and a current, actual value of aircraft backward air deceleration or ground braking,
- an indication of controlled values, when the lever is operated in a manual mode, of aircraft forward thrust and of aircraft backward air deceleration or ground braking, and when the lever is operated in automatic mode, of aircraft forward thrust and of aircraft backward air deceleration or ground braking,
- an indication of a range of authority allocated to forward maximum thrust and backward maximum deceleration, and
- an indication of activated automatic modes.

18. The HMI according to claim **17**, wherein the activated automatic modes are selected from TOGA, Flex, Climb, Self-delay, Brake-To-Vacate (BTV), Max rejected takeoff (RTO) braking, and Soft RTO optimized braking.

19. The HMI according to claim **18**, wherein (i) TOGA is an automatic mode of application of maximum thrust (TOGA thrust); (ii) Flex is an automatic mode using a reduced thrust during takeoff or during go-around compared to the maximum thrust (TOGA); (iii) Climb is an automatic mode using a reduced thrust for the climbing phase compared to the maximum thrust (TOGA); (iv) Self-delay is an automatic mode to reduce the thrust toward the IDLE level during the flare-out phase on landing; (v) Brake-To-Vacate (BTV) is an automatic braking mode to reach an exit ramp at an adequate speed while optimizing runway occupation time and brake wear; (vi) Max rejected takeoff (RTO) braking is a mode which uses all the aircraft's braking capacity following cancellation of take-off; and (vii) Soft RTO optimized braking is a mode following a take-off cancellation

20. A system for displaying information relative to the energy of an aircraft, the system comprising:

- a control unit,
- a control interface linked to the control unit by a first link, the control interface being connected to a lever by which a pilot increases and decreases aircraft energy by a plurality of sensors,
- a display device linked to the control unit by a second link, the display device including a display comprising:
 - a cursor symbolizing a lever handled by a pilot to control the energy of the aircraft,
 - a race including
 - an upper part corresponding to a forward direction in which the lever is moved to increase the energy of the aircraft,
 - a lower part corresponding to a reverse direction in which the lever is moved to decrease the energy of the aircraft, and
 - an idle position located between the upper and lower parts,
 - the cursor being movable so as to follow actual strokes of the lever to increase or decrease the energy of the aircraft and to return to the idle position in the race when the lever is not being handled,

an upper shutter positioned over the upper part of the race which changes in length as the cursor moves in the upper part of the race, the length of the upper shutter symbolizing an ordered value in the increase in the energy of the aircraft,

a lower shutter positioned over the lower part of the race which changes in length as the cursor moves in the lower part of the race, the length of the lower shutter symbolizing an ordered value in the decrease in the energy of the aircraft,

an upper column having a height symbolizing a current value in actual aircraft push, the upper column changing in height as the actual aircraft push changes and the length of the upper shutter changes in response to the ordered value in the increase in the energy of the aircraft,

a lower column having a height symbolizing a current value in actual aircraft braking, the lower column changing in height as the actual aircraft braking changes and the height of the lower shutter changes in response to the ordered value in the decrease in the energy of the aircraft, and

a memory button for a selected aircraft push or aircraft deceleration when the lever is operated in a manual mode, and for a range of authority when the lever is operated in an automatic mode, and a Go-Lever button which enables automatic triggering of a flight phase change.

21. The system according to claim **20**, wherein the display further includes a scale to provide measures of ordered and actual values in the increase and decrease in the energy of the aircraft.

22. The system according to claim **21**, wherein the scale depicts ordered values in the increase and decrease in the energy of the aircraft and actual values of aircraft push as percentages of a maximum limit in aircraft energy, and actual values of aircraft braking as percentages of a minimum limit in aircraft energy.

23. The system according to claim **22**, wherein the display further comprises second upper and lower shutters which indicate respectively the maximum and minimum limits in aircraft energy.

* * * * *