

(19)



(11)

**EP 4 273 055 B1**

(12)

**EUROPEAN PATENT SPECIFICATION**

(45) Date of publication and mention of the grant of the patent:  
**29.01.2025 Bulletin 2025/05**

(51) International Patent Classification (IPC):  
**B65B 11/02<sup>(2006.01)</sup>**

(21) Application number: **23163543.4**

(52) Cooperative Patent Classification (CPC):  
**B65B 11/025; B65B 2210/20**

(22) Date of filing: **22.03.2023**

**(54) STRUCTURE FOR WRAPPING MACHINE**

STRUKTUR FÜR EINE VERPACKUNGSMASCHINE

STRUCTURE POUR MACHINE D'EMBALLAGE

(84) Designated Contracting States:  
**AL AT BE BG CH CY CZ DE DK EE ES FI FR GB GR HR HU IE IS IT LI LT LU LV MC ME MK MT NL NO PL PT RO RS SE SI SK SM TR**

- **Bereber Goiricelaya, Roberto**  
**46410 Sueca (ES)**
- **López Carrillo, Luis Miguel**  
**46021 Valencia (ES)**

(30) Priority: **24.03.2022 ES 202230500 U**

(74) Representative: **Soler Lerma, Santiago**  
**Vitoria de Lerma Asociados**  
**International Department**  
**C/Poeta Querol nº 1 pta 10**  
**46002 Valencia (ES)**

(43) Date of publication of application:  
**08.11.2023 Bulletin 2023/45**

(73) Proprietor: **Aranguren Comercial del Embalaje, S.L.U.**  
**46130 Massamagrell Valencia (ES)**

(56) References cited:  
**EP-A1- 2 258 652 EP-A1- 3 081 526**  
**ES-A1- 2 341 209 US-A- 5 423 163**

(72) Inventors:  
• **Rubio Casalta, Valentín**  
**46019 Valencia (ES)**

**EP 4 273 055 B1**

Note: Within nine months of the publication of the mention of the grant of the European patent in the European Patent Bulletin, any person may give notice to the European Patent Office of opposition to that patent, in accordance with the Implementing Regulations. Notice of opposition shall not be deemed to have been filed until the opposition fee has been paid. (Art. 99(1) European Patent Convention).

**Description**

**[0001]** The invention as its name indicates relates to a structure for a rotating-arm wrapping machine that, being light, is reinforced in such a way as to allow supporting film reels of greater weight and size, thus minimising the machine's downtimes due to reel change.

**[0002]** The structure comprises a series of elements arranged and joined together in such a way as to keep the assembly stabilised and prevent torsion and bending when the inertial forces present during wrapping, especially due to the movement of the reel, act on it.

**[0003]** The technical field to which the invention belongs is that of transportable and wrapping machinery.

**BACKGROUND OF THE INVENTION**

**[0004]** There is currently a wide variety of wrapping machines that have a moving arm that supports a reel carriage, said carriage supplies the packaging film material by means of the movement of the moving arm around the load to be packaged.

**[0005]** The applicant's own patent ES2341209 relates to a wrapping machine that incorporates a reel carriage that has a system for supplying and tensioning the packaging material comprising a device that integrates an adherent-surface roller engaged to an adjustable brake, both elements being arranged on a plate fixed to the reel carriage.

**[0006]** The applicant's own patent EP2258652 relates to a pallet truck machine that travels moved by the force of an electric motor, which has been provided with additional feeding elements that, together with other means that are incorporated, improve its stability in such a way that the improvement of stability and the addition of feeding elements make it possible to join thereto, through the appropriate anchorings, functional elements that require electric power such as a wrapping device.

**[0007]** Utility model ES1013952U relates to a rotating-arm wrapping machine and fixed structure with an inverted L-shape wherein the rotating arm has at one end thereof a reel carriage and wherein the carriage drive motor is arranged at the base of the fixed structure.

**[0008]** An apparatus for wrapping loads on a pallet with a film is known from US 5423163 A.

**[0009]** These types of wrapping machines have been gradually automated, ensuring that each and every one of the operations of a wrapping cycle are performed without the need for human intervention.

**[0010]** However, no suitable solution has been found for the operation of replacing an already finished film reel with a new one, at least in mobile wrapping machines.

**[0011]** To space out the reel change operations, an attempt is made to load reels of greater length, however, as the length of the film reel increases, its weight and size increases, so that when the moving arm orbits the load to be wrapped, the inertial force increases, destabilising the assembly.

**DESCRIPTION OF THE INVENTION**

**[0012]** To resolve the aforementioned problems, the invention relates to a light structure for a wrapping machine of those comprising a rotating arm, which allows the reel carriage to support reels of film of greater capacity, i.e. of greater film length and, therefore, of greater weight and volume.

**[0013]** It should be noted that the inertial force generated by the rotating arm of a wrapping machine during its rotational movement increases with the weight of the reel that it supports so that heavier the reels the greater the forces that the structure must withstand. The risk of torsion is usually greater the lighter the structure, however, through the structure that is recommended, the aim is to reduce that risk.

**[0014]** The invention is preferably applied to mobile wrapping machines, of those arranged on pallet trucks, since in these the greatest advantage supposes a light structure and, moreover, those that have greater stability requirements so that the reduction of the torque results in greater stability.

**[0015]** To do this, the structure comprises:

- A base with means for anchoring to a support surface, preferably a pallet truck, but it may be another surface.
- An inverted L-shaped outer branch projecting upwards from the base and comprising a series of interconnected reticular elements. This external branch in turn comprises:
  - o At least two ascending columns, preferably vertical, joined with at least two horizontal beams. The ascending and horizontal columns have an elbow-shaped joint through a bracket.
  - o At least one tensioner between the ascending columns that provides rigidity to the structure preventing torsion.
  - o A closing piece that joins the beams, this piece being arranged at the outer end of the beams, wherein the shaft that communicates the outer branch with an inner branch is supported.
- An inner branch in the shape of a rotating inverted L-shape. It has a horizontal and a vertical section. At one end of the horizontal section there is the axis of rotation and, at the other end of this horizontal section, there is the joint with the vertical section.
- At least one tie rod arranged on the rear part of the structure that joins the base with the outer branch exerting a compressive force that stiffens the assembly.
- A reel carriage arranged on the vertical section of the inner branch.

**[0016]** In a possible embodiment, the structure comprises a series of reticular elements interconnectable

with each other and with other elements such as tensioners, closing pieces, or shafts among others. These reticular elements, suitable for the formation of structures, are known in the sector as "truss", which will be used herein in the indicated sense. In a preferred embodiment, the structure has two tie rods that join the base of the structure with the outer branch.

**[0017]** The tie rods form an angle with respect to the columns, so that the vertical component pre-compresses the columns to reduce the tensile stresses, and the horizontal component to reduce the bending stress forward (with the arm extended) and to a lesser extent rearward, since the torsion is a composition of traction and bending.

**[0018]** Likewise, the tensioners that are solidly joined to the ascending columns, prevent the lateral torsion of the outer branch especially during the wrapping cycle by orbiting the reel carriage projecting laterally and generating a strong inertial tension.

#### DESCRIPTION OF THE FIGURES

##### **[0019]**

FIGURE 1 shows in a lateral plane the structure object of the invention where we can see the base (1) suitable for anchoring to the ground or to a pallet truck, the outer branch (10) comprising the ascending columns (2) which in this case only one of them is seen and the beams (3), the inner branch (11) comprising the horizontal section (4) and the vertical section (5) and the reel carriage (6), the closing piece (7) joining the outer and inner branches unifying the ends of the beams and supporting the shaft (8) whereon the inner L rotates, the tie rods (9) between the base and the outer branch.

FIGURE 2 shows, from another perspective, the structure wherein the ascending columns (2) and the beams (3), the closing piece (7) and a tensioner (12) between the ascending columns are clearly seen.

FIGURE 3 shows in detail and in explosion the beams (3), the closing piece (7) and the joining bracket (14) between the ascending columns (not shown here) and the beams. The closing part has the bushing (13) for the shaft that joins the outer and inner branches.

#### DESCRIPTION OF AN EMBODIMENT

**[0020]** A form that is not unique but merely explanatory of the invention is described below.

**[0021]** The invention relates to a light structure suitable for anchoring to a pallet truck. This structure resolves the problem of being able to increase the capacity of the film reels in a wrapping machine in such a way as to decrease

the downtimes of the machine and the requirements of human intervention due to reel replacement.

**[0022]** The structure must be light so as not to overload the pallet truck that transports it but at the same time must be able to resist without torsion the inertial forces generated by the rotating arm of the wrapping machine during its rotational movement, both laterally and anteroposteriorly, taking into account the increase in weight of the reel as its load increases.

**[0023]** For this purpose, the structure comprises:

1. A suitable base for anchoring to the body of a pallet truck.

2. A fixed, inverted L-shaped outer branch (10) with:

a. Two parallel vertical ascending columns (2) arranged in a plane perpendicular to that of the movement of the pallet truck.

b. Two horizontal beams (3) joined at one of their ends to the columns through a bracket (14) forming an elbow with the columns. The beams are convergent forming a triangle having the apex distant from the columns, the beams being joined at that apex by a closing piece (7) comprising a bushing (13) for housing the shaft that communicates the outer branch with the inner and whereon the inner rotates.

c. A tensioner (12) between the ascending columns.

3. An inverted L-shaped inner branch (11) smaller in size than the outer branch with:

a. A horizontal section (4) that is attached at one of its ends to a shaft housed in a bushing (13) of the closure piece (7). The lower branch rotates on said shaft.

b. A vertical section (5) descending from the vertical section where to it is joined at one of its ends.

c. A reel carriage (6) arranged in the vertical section.

4. Two tie rods (9) between the base and the outer branch.

**[0024]** Once the wrapping cycle has started, the inner branch (11), loaded with the film reel, rotates on the shaft housed in the bushing (13) generating high inertial forces that must be supported by the structure of the machine, especially by the outer branch.

**[0025]** In order to assume these inertial forces and for the machine to have an optimal behaviour, without antero-frontal or lateral torsion of the outer branch, it has been provided with a light structure in such a way that the transport machine whereon it is mounted is not overloaded and so that the weight of the structure itself, especially the internal branch that rotates, does not con-

tribute to increasing the inertial forces.

[0026] The pre-compression tie rods (9) are arranged at an angle to the columns and exert a vertical pre-compression force on them to reduce the tensile stresses and a horizontal force to reduce the forward bending stress, especially when the rotating inner branch is fully deployed.

[0027] On the other hand, the vertical columns, parallel to each other, generate a solid block avoiding lateral torsion at the times of inertia wherein the reel is in its travel by one of the sides of the machine. To improve this block behaviour, a tensioner (12) is incorporated between the ascending columns in such a way that both columns are stiffened with a common behaviour.

[0028] The bracket (14) also acts as a tensioner between the columns and, moreover, as a joining element between the columns (2) and the beams (3).

[0029] The beams are fixed to the bracket and, together with this, form a triangle whose vertex is a closing piece (7) that joins the beams at their end opposite the bracket. This closing piece houses the shaft that communicates the outer and the inner branch.

[0030] The triangle shape formed by the beams, the bracket and the closing piece is resistant and the torsion that the inertial force can cause are avoided.

[0031] In the proposed embodiment, the outer branch, with the exception of the bracket and the closing piece, is made of trusses, assembled with each other and fixed by screws.

[0032] They are standard elements in the industry so their repair or replacement in case of breakage is simple and fast.

## Claims

1. STRUCTURE FOR WRAPPING MACHINE comprising a fixed inverted L-shaped outer branch (10) and an also inverted L-shaped inner branch (11) that rotates on a shaft and that supports a reel carriage **characterised in that** the outer branch comprises ascending columns (2) with tensioners (12) arranged between them, these columns are joined at their upper part to beams (3) through a bracket (14), the beams are joined to the columns at one of their ends while at their other end they are solidly joined by a closing piece (7) that supports the bushing (13) of the shaft whereon the inner branch (11) will rotate and between the outer branch and the base there is at least one pre-compression tie rod (9).
2. STRUCTURE FOR WRAPPING MACHINE according to claim 1, **characterised in that** the columns (2) are vertical and parallel to one another.
3. STRUCTURE FOR WRAPPING MACHINE according to claim 1, **characterised in that** the beams (3) are convergent and together with the bracket (14)

and the closing piece (7) form a triangle whose vertex is the closing piece.

4. STRUCTURE FOR WRAPPING MACHINE according to claim 1, **characterised in that** the at least one pre-compression tie rod (9) is arranged at an angle with respect to the columns and exerts a pre-compression vertical force thereon.
5. STRUCTURE FOR WRAPPING MACHINE according to claim 1, **characterised in that** the outer branch comprises a plurality of reticular elements.
6. STRUCTURE FOR WRAPPING MACHINE according to claim 5, **characterised in that** the reticular elements are trusses.

## Patentansprüche

1. STRUKTUR FÜR UMWICKLUNGSMASCHINE, die einen festen inversen L-förmigen äußeren Zweig (10) und einen ebenfalls inversen L-förmigen inneren Zweig (11) umfasst, der sich auf einer Welle dreht und einen Rollenwagen trägt, **dadurch gekennzeichnet, dass** der äußere Zweig aufsteigende Säulen (2) mit Spannvorrichtungen (12) umfasst, die zwischen ihnen angeordnet sind, wobei diese Säulen an ihrem oberen Teil mit Trägern (3) über eine Halterung (14) verbunden sind, wobei die Träger an einem ihrer Enden mit den Säulen verbunden sind, während sie an ihrem anderen Ende durch ein Verschlussstück (7) fest verbunden sind, das die Buchse (13) der Welle trägt, auf der sich der innere Zweig (11) dreht, und wobei sich zwischen dem äußeren Zweig und der Basis mindestens eine Vorkompressions-Spurstange (9) befindet.
2. STRUKTUR FÜR UMWICKLUNGSMASCHINE nach Anspruch 1, **dadurch gekennzeichnet, dass** die Säulen (2) vertikal und parallel zueinander sind.
3. STRUKTUR FÜR UMWICKLUNGSMASCHINE nach Anspruch 1, **dadurch gekennzeichnet, dass** die Balken (3) konvergent sind und zusammen mit der Halterung (14) und dem Verschlussstück (7) ein Dreieck bilden, dessen Spitze das Verschlussstück ist.
4. STRUKTUR FÜR UMWICKLUNGSMASCHINE nach Anspruch 1, **dadurch gekennzeichnet, dass** die mindestens eine Vorkompressions-Zugstange (9) in einem Winkel zu den Säulen angeordnet ist und eine vertikale Vorkompressionskraft auf diese ausübt.
5. STRUKTUR FÜR UMWICKLUNGSMASCHINE nach Anspruch 1, **dadurch gekennzeichnet, dass**

der äußere Zweig eine Vielzahl von netzartigen Elementen umfasst.

6. STRUKTUR FÜR UMWICKLUNGSMASCHINE nach Anspruch 5, **dadurch gekennzeichnet, dass** die netzartigen Elemente Streben sind. 5

### Revendications

- 10
1. STRUCTURE POUR MACHINE D'EMBALLAGE comprenant une branche extérieure fixe en forme de L inversé (10) et une branche intérieure également en forme de L inversé (11) qui tourne sur un arbre et qui supporte un chariot de bobine, **caractérisée en ce que** la branche extérieure comprend des colonnes ascendantes (2) avec des tendeurs (12) disposés entre elles, ces colonnes sont jointes au niveau de leur partie supérieure à des poutres (3) par l'intermédiaire d'un support (14), les poutres sont jointes aux colonnes au niveau d'une de leurs extrémités tandis qu'au niveau de leur autre extrémité elles sont solidement jointes par une pièce de fermeture (7) qui supporte la douille (13) de l'arbre sur laquelle la branche intérieure (11) tournera, et entre la branche extérieure et la base se trouve au moins un tirant de précompression (9). 15 20 25
2. STRUCTURE POUR MACHINE D'EMBALLAGE selon la revendication 1, **caractérisée en ce que** les colonnes (2) sont verticales et parallèles les unes aux autres. 30
3. STRUCTURE POUR MACHINE D'EMBALLAGE selon la revendication 1, **caractérisée en ce que** les poutres (3) sont convergentes et forment avec le support (14) et la pièce de fermeture (7) un triangle dont le sommet est la pièce de fermeture. 35
4. STRUCTURE POUR MACHINE D'EMBALLAGE selon la revendication 1, **caractérisée en ce que** l'au moins un tirant de précompression (9) est agencé selon un certain angle par rapport aux colonnes et exerce une force verticale de précompression sur celles-ci. 40 45
5. STRUCTURE POUR MACHINE D'EMBALLAGE selon la revendication 1, **caractérisée en ce que** la branche extérieure comprend une pluralité d'éléments réticulaires. 50
6. STRUCTURE POUR MACHINE D'EMBALLAGE selon la revendication 5, **caractérisée en ce que** les éléments réticulaires sont des fermes. 55

Fig.1

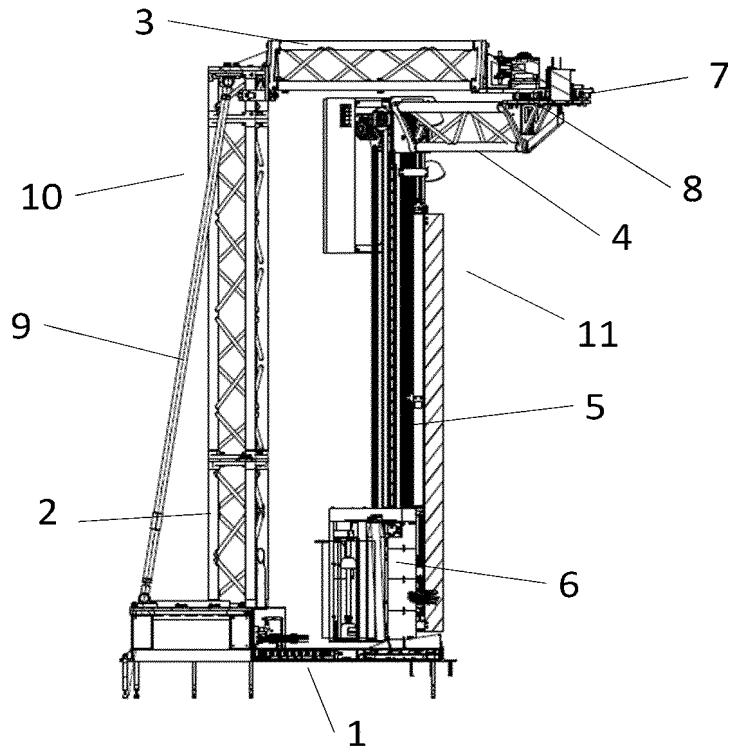

2/3

Fig.2

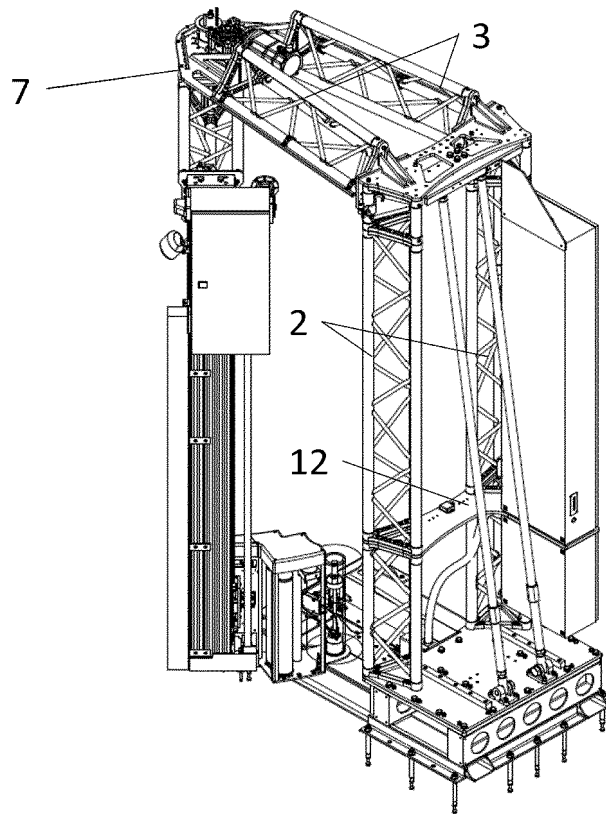
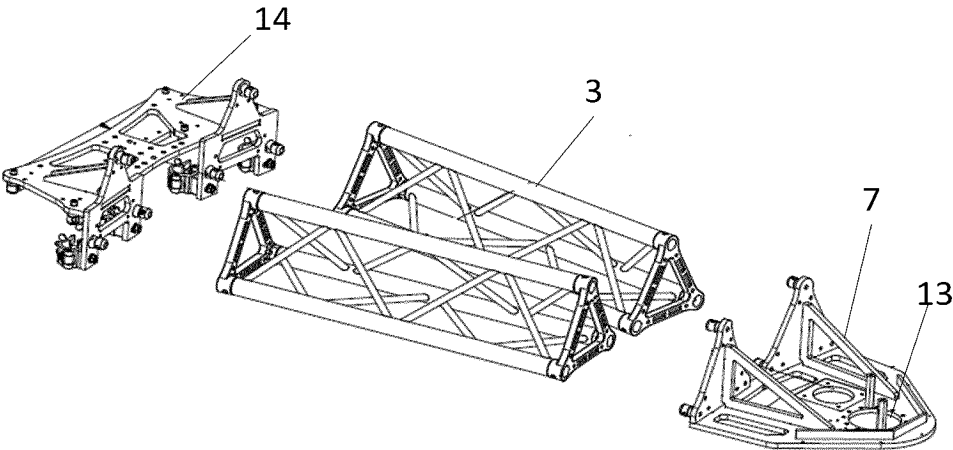

Fig.3



**REFERENCES CITED IN THE DESCRIPTION**

*This list of references cited by the applicant is for the reader's convenience only. It does not form part of the European patent document. Even though great care has been taken in compiling the references, errors or omissions cannot be excluded and the EPO disclaims all liability in this regard.*

**Patent documents cited in the description**

- ES 2341209 [0005]
- EP 2258652 A [0006]
- ES 1013952 U [0007]
- US 5423163 A [0008]