

No. 856,679.

PATENTED JUNE 11, 1907.

H. & A. J. BUCKLAND.
ADJUSTABLE STAND.
APPLICATION FILED OCT. 30, 1905.

2 SHEETS—SHEET 1.

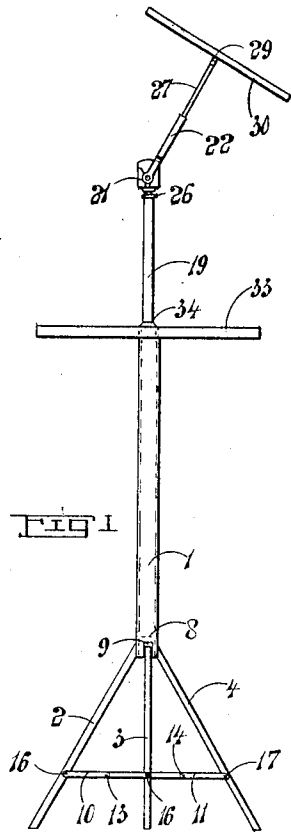

FIG 1

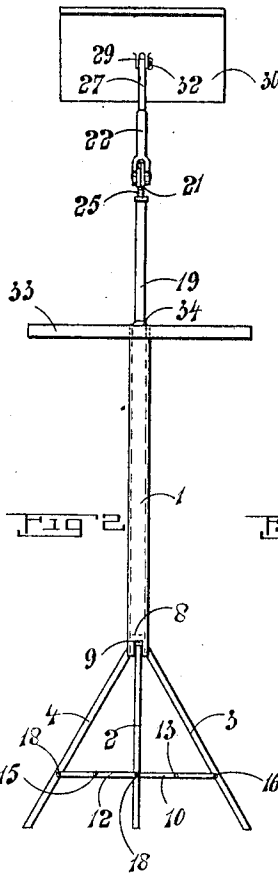

FIG 2

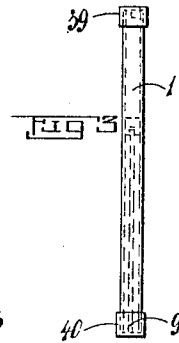

FIG 3

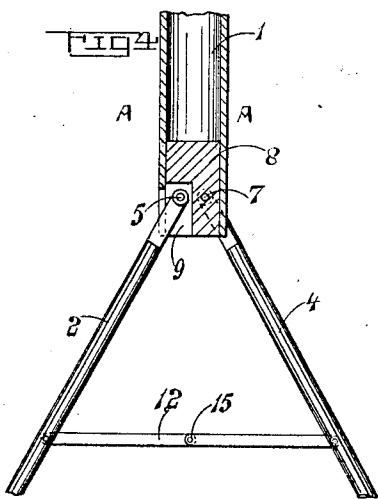

FIG 4

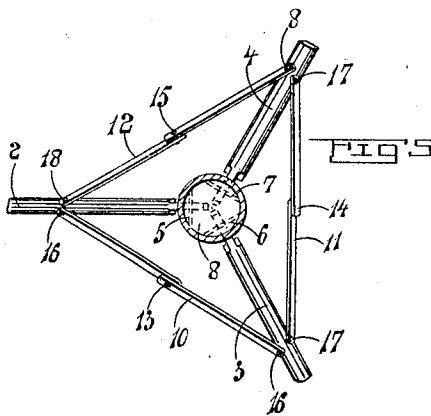

FIG 5

Witnesses
Ed. Baldwin
J. Stratton

Inventors
Henry Buckland
Annie Jane Buckland
By Lewis H. Hayward
Attorney.

No. 856,679.

PATENTED JUNE 11, 1907.

H. & A. J. BUCKLAND.
ADJUSTABLE STAND.

APPLICATION FILED OCT. 30, 1905.

2 SHEETS—SHEET 2.

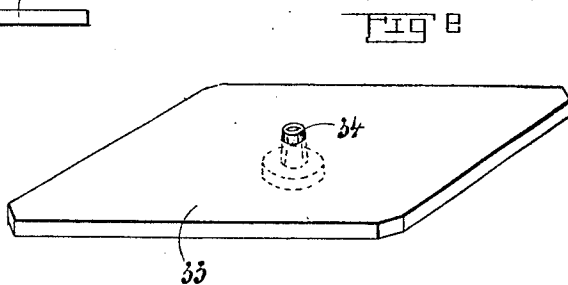
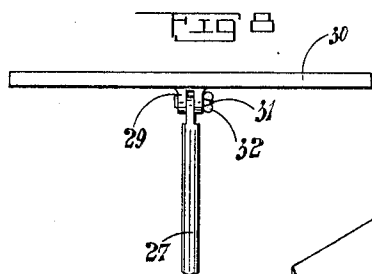
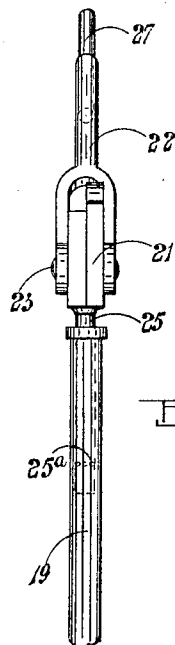
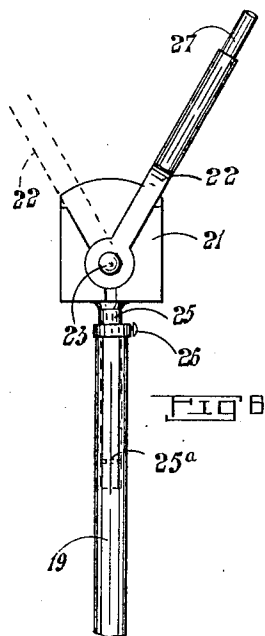

FIG. 10

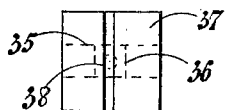
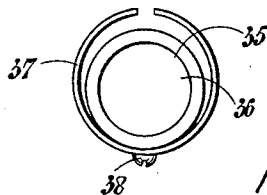

FIG. 11



Witnesses
Ed. Baldwin
J. Matern

INVENTORS
Henry Buckland
Amie Jane Buckland
By *Alfred Stegward*
Attorney

UNITED STATES PATENT OFFICE.

HENRY BUCKLAND AND ANNIE JANE BUCKLAND, OF KIATOA,
WAIKOUAITI, NEW ZEALAND.

ADJUSTABLE STAND.

No. 856,679.

Specification of Letters Patent.

Patented June 11, 1907.

Application filed October 30, 1905. Serial No. 284,946.

To all whom it may concern:

Be it known that we, HENRY BUCKLAND and ANNIE JANE BUCKLAND, subjects of His Majesty the King of Great Britain and Ireland, residing at Kiatoa, Waikouaiti, in the Provincial District of Otago, in the Colony of New Zealand, have invented certain new and useful Improvements in Portable Adjustable Stands, to be used for supporting a table and a mirror or other articles of the same nature, of which the following is a specification.

Our invention relates to improvements in stands in which a tubular pillar has a slidable block, whereto are pivoted legs united together by jointed stay rods, which legs and stay rods are adapted to be packed inside the tubular pillar. A tube fits telescopically into the top of the tubular pillar and is provided with a quadrant bracket, to which an oscillating arm is pivoted. The upper part of this arm telescopes into the lower part and is pivoted to a mirror, which is thus adjustable as desired. A table top has a cap piece adapted to fit the top of the pillar. Caps are provided for closing the pillar after the various parts have been packed inside the pillar. The rod, tube and pillar are secured by thumb screws or a clamp of special construction.

Our invention is illustrated in the accompanying drawings in which:—

Figure 1. is a side elevation. Fig. 2. a rear elevation of the invention. Fig. 3. is an elevation of a pillar. Fig. 4. is a sectional elevation of the lower part of the pillar. Fig. 5 is a sectional plan on line A—A of Fig. 4. Fig. 6. is a side elevation. Fig. 7. is a rear elevation of the upper part of the pillar. Fig. 8. is a side elevation. Fig. 9. a perspective view of the table top. Fig. 10. is a side view and Fig. 11. a plan of a clamp.

Referring to the drawings:—The tubular pillar 1, is provided with extending legs 2, 3 and 4, which are pivoted upon pins 5, 6 and 7, passing through a block 8, fitted slidably within the pillar and having slots 9 to receive the ends of the said legs.

The legs are connected together by stay rods 10, 11 and 12, jointed together at their middle part by pins 13, 14 and 15, and pivoted at their ends to the legs by pins 16, 17 and 18.

A table top clearly shown in Fig. 9 is secured to the top of the pillar 1 by means of a cap piece 34 secured into the table top 33 and fitting upon the end of the pillar 1.

A tube 19 fits telescopically within the pillar 1, and is screwed into a hole 36 of a block 35, to which is secured a circular spring 37. By a screw 38 the spring and block are passed into the pillar 1 and support the tube 19. By the friction of the spring against the interior of the tube the upper end of the tube is provided for a quadrant bracket 21, upon which is pivoted an oscillating arm 22.

A stem 25 integral with quadrant bracket 21 is secured thereto by a thumb screw 26, which passes through a collar formed upon the top of the tube 19 and fits into a groove 25^a formed in the stem 25 whereby the tube is revoluble in the pillar 19.

An arm 22 is in two parts the upper part 27 fitting telescopically within the other part, and being secured thereto by a semi-circular spring secured to the part 27 similar to the spring 37. The upper end of the arm is connected to a bracket 29 upon the back or edge of the mirror 30 which is fixed in position by a bolt 31 and thumb nut 32, clearly shown in Fig. 8.

When not in use the legs 2, 3 and 4 are folded and pushed into the pillar 1, which is then closed at both ends by caps 39 and 40 which fit tightly upon the ends of the pillar.

What we do claim and desire to secure by Letters Patent of the United States is:—

1. A stand for the purpose indicated comprising a tubular pillar, a block having slots and slidable within the pillar, legs pivoted to the block, stay rods connecting the legs together and jointed at their middle part, a tube telescoping into the pillar, a thumb screw securing the tube within the pillar, a quadrant bracket having a stem fitting into the top of the tube, a thumb screw securing the stem to the tube, a tubular arm pivoted to the quadrant bracket the upper part of the arm telescoping into the lower part, a pin fitting holes provided in the quadrant and a hole in the arm, a mirror, a bracket upon the back of the mirror, and a pin by which the mirror is pivoted to the oscillating arm, substantially as set forth.

2. A stand for the purpose indicated comprising a tubular pillar, a block having slots and slidable within the pillar, legs pivoted to the block, stay rods connecting the legs together and jointed at their middle part caps
5 fitting the ends of the pillar, a tube telescoping into the pillar, a thumb screw securing the tube within the pillar, a quadrant bracket having a stem fitting into the top of
10 the tube, a thumb screw securing the stem to the tube, a tubular arm pivoted to the quadrant bracket the upper part of the arm telescoping into the lower part, a pin fitting holes provided in the quadrant and a hole in

the arm, a mirror, a bracket upon the back of
15 the mirror, a pin by which the mirror is pivoted to the oscillating arm, a table top, a cap piece screwed into the table top and having a hole to fit upon the end of the pillar, substantially as set forth. 20

In testimony whereof we have signed our names to this specification in the presence of two witnesses.

HENRY BUCKLAND.
ANNIE JANE BUCKLAND.

Witnesses:

JOHN HACKISACK,
S. F. MIRAM.