

*Hydraulic Engineering
Harbors,
Fortifications & defenses, Turrets.*

(No Model.)

5 Sheets—Sheet 1.

J. B. G. A. CANET.
ARMORED TURRET.

No. 453,545.

Patented June 2, 1891.

Fig. 1.

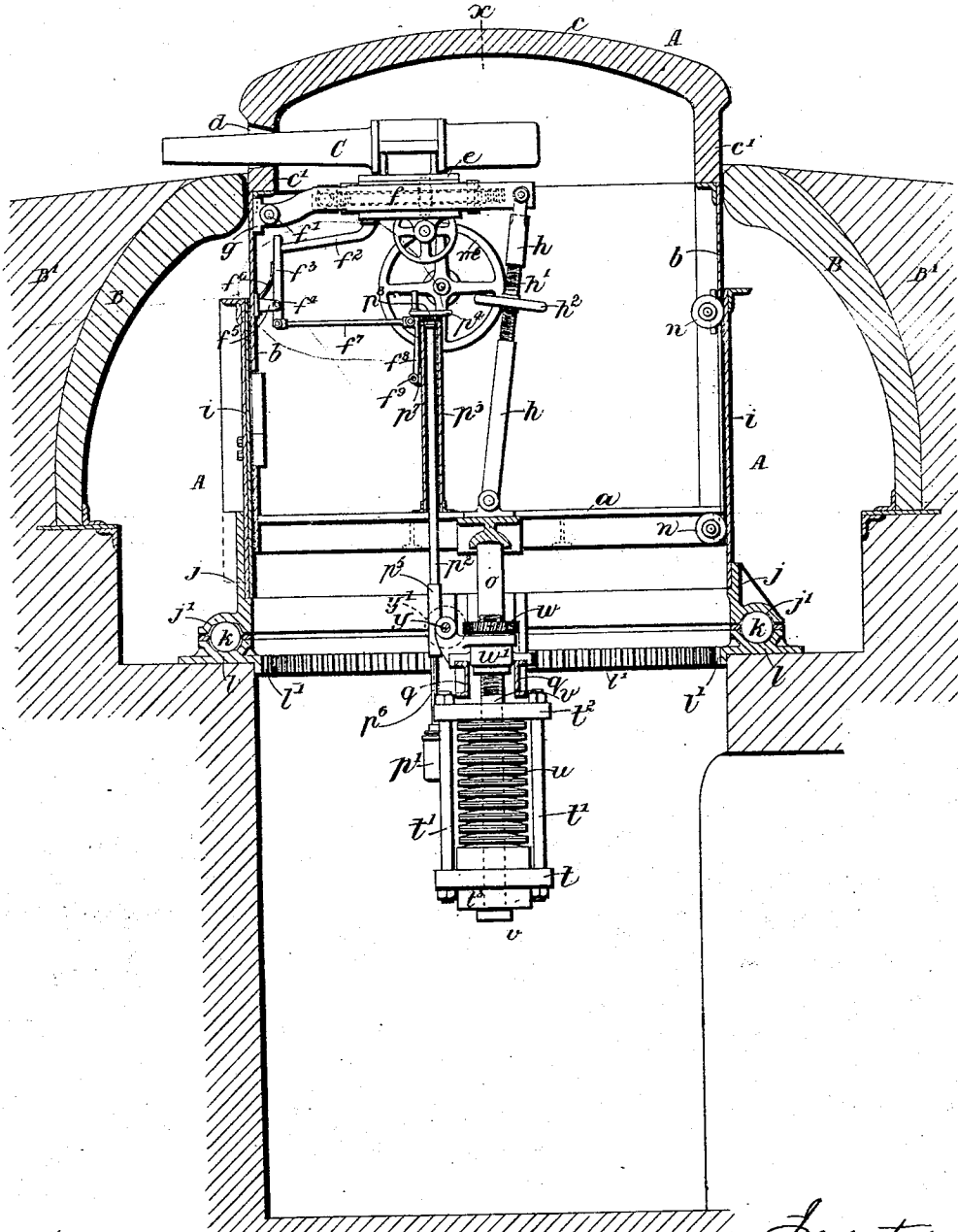

Witnesses:
J. A. Rutherford
Chas. B. Silden

Inventor:
Jean B. G. A. Canet.
By James L. Norris, atty.

(No Model.)

J. B. G. A. CANET.
ARMORED TURRET.

No. 453,545.

Patented June 2, 1891.

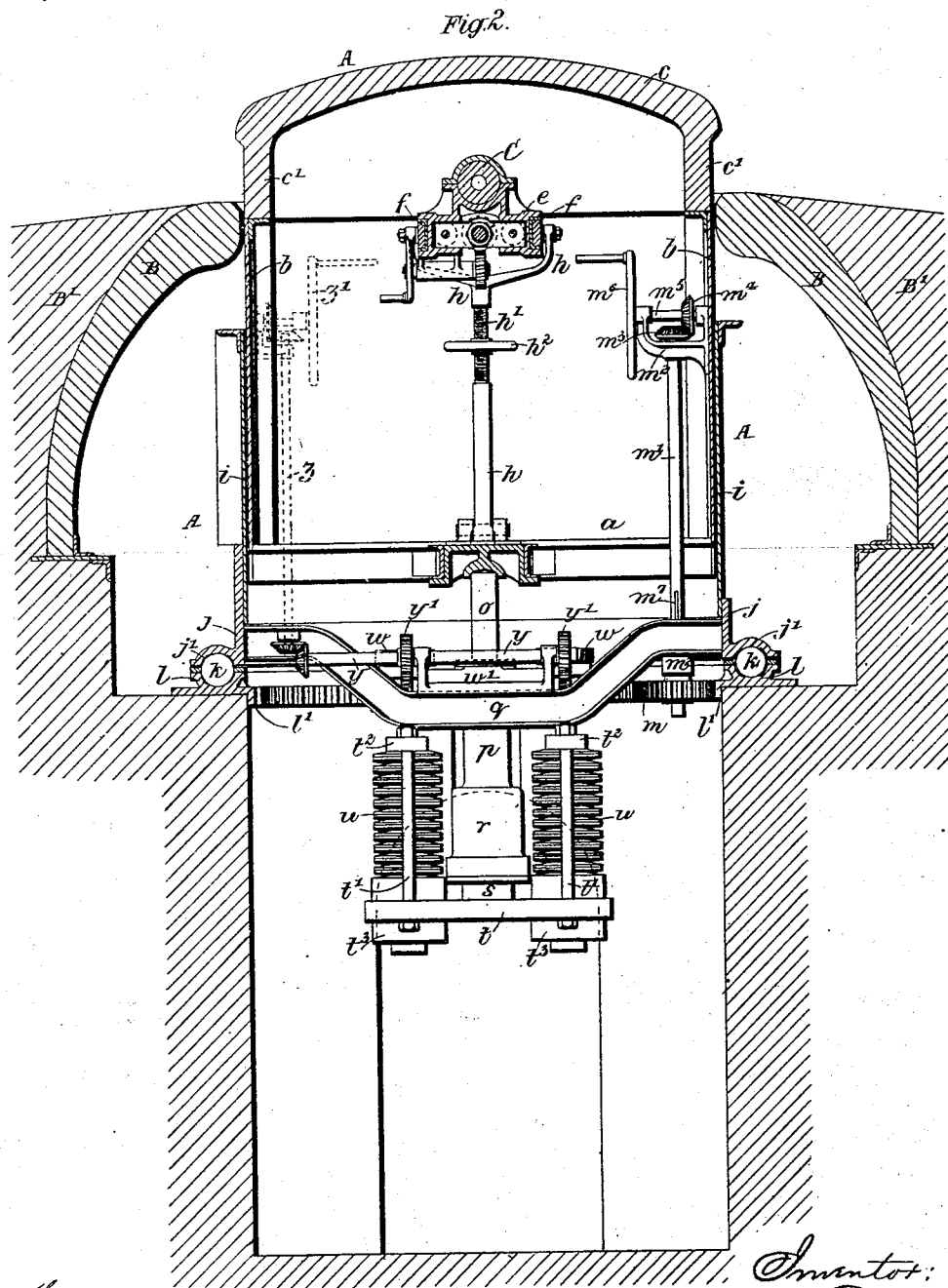

Witness:
J. A. Rutherford.
Chas. D. Stout

Inventor:
Jean B. G. A. Canet.
By James L. Norris.

(No Model.)

5 Sheets—Sheet 3.

J. B. G. A. CANET.
ARMORED TURRET.

No. 453,545.

Patented June 2, 1891.

Fig. 3.

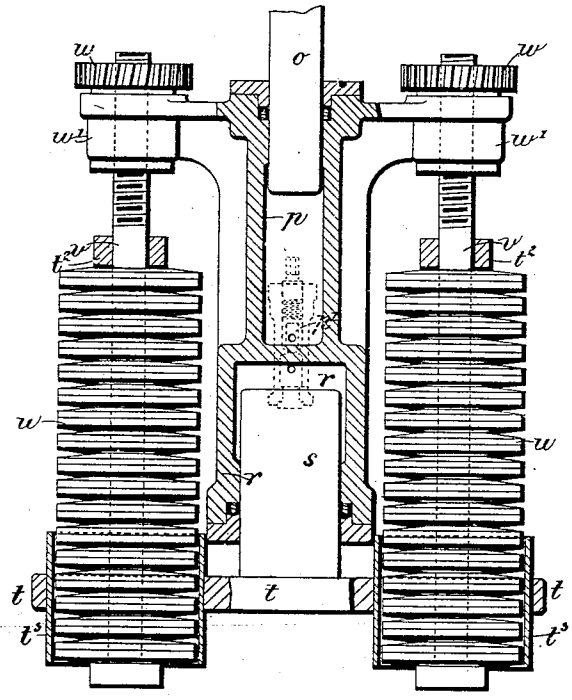
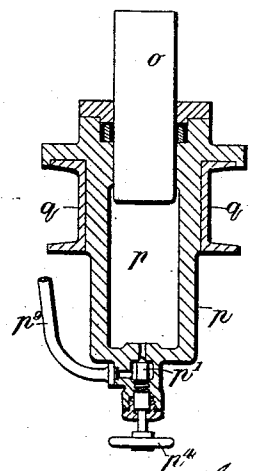

Fig. 6.



Witnesses:
J. A. Rutherford
Chas. B. Kiser

Inventor:
Jean B. G. A. Canet
By James L. Norris,
att'y.

(No Model.)

5 Sheets—Sheet 4.

J. B. G. A. CANET.
ARMORED TURRET.

No. 453,545.

Patented June 2, 1891.

Fig. 4.

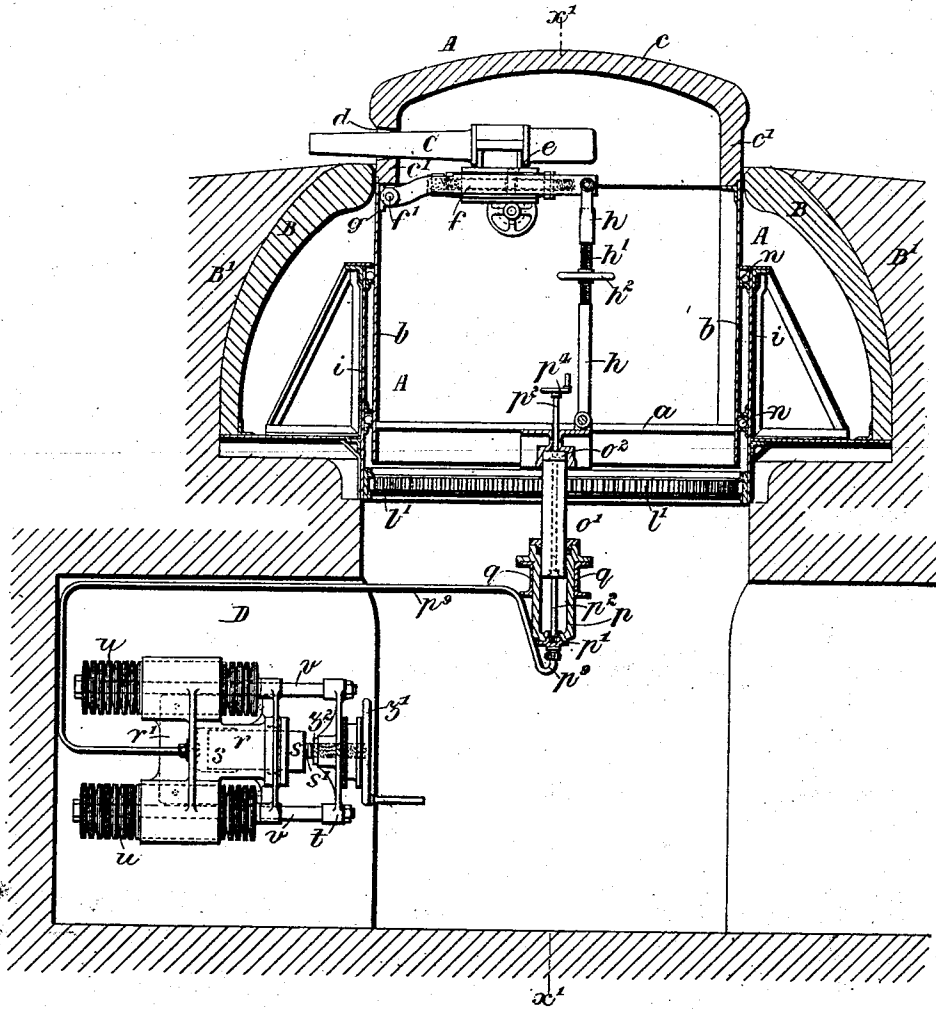

Witnesses:
J. A. Rutherford
Chas. B. Tilden

Inventor:
Jean B. G. A. Canet
By James L. Norris
att'y.

8. OMDNANCE,
Mounts,
8 Disappearing Gun.

61. - Hydraulic Engineering
Harbors
Fortifications & defenses
Turrets

EXAMINED

(No Model.)

5 Sheets—Sheet 5

J. B. G. A. CANET.
ARMORED TURRET.

No. 453,545.

Patented June 2, 1891.

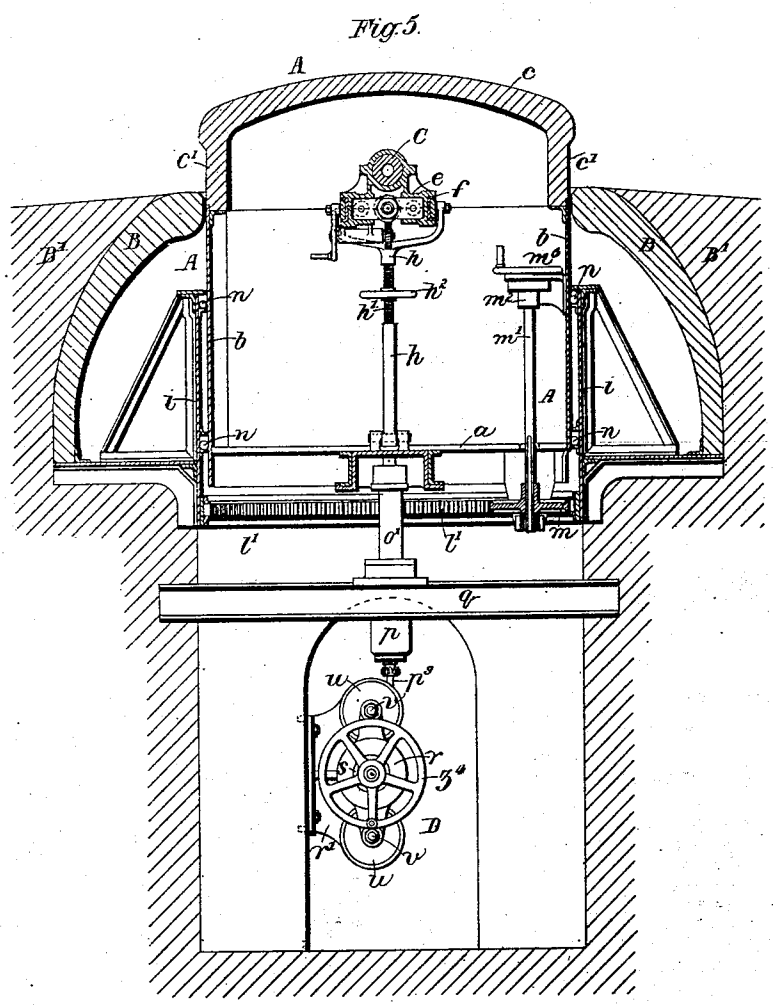

Witnesses:
J. A. Rutherford
Chas. B. Fildner

Inventor:
Jean B. G. A. Canet
James L. Norris
attor.

UNITED STATES PATENT OFFICE.

JEAN BAPTISTE GUSTAVE ADOLPHE CANET, OF PARIS, FRANCE, ASSIGNOR
OF ONE-HALF TO SIR JOSEPH WHITWORTH & COMPANY, LIMITED, OF
OPENSHAW, ENGLAND.

ARMORED TURRET.

SPECIFICATION forming part of Letters Patent No. 453,545, dated June 2, 1891.

Application filed June 11, 1889. Serial No. 313,876. (No model.) Patented in France February 25, 1888, No. 188,964.

To all whom it may concern:

Be it known that I, JEAN BAPTISTE GUSTAVE ADOLPHE CANET, civil engineer, a citizen of the Republic of France, and a resident of Paris, France, have invented new and useful Improvements in Disappearing Armored Turrets, (for which I have obtained Letters Patent in France, No. 188,964, dated February 25, 1888,) of which the following is a specification, reference being had to the accompanying drawings.

My invention relates to disappearing armored turrets.

My said invention comprises the combination of two hydraulic cylinders which may be placed in communication with each other, the ram or plunger of one of the said cylinders supporting the weight of the turret, and the ram or plunger of the other cylinder being loaded by springs provided with means for adjusting the same to regulate their initial compression. By this arrangement the turret may, after the firing of the gun mounted therein, be allowed to disappear slowly or quickly, as desired.

My said invention also comprises means for raising the turret after its disappearance to permit the firing of the gun over the wall or parapet, and my said invention comprises further improvements hereinafter set forth.

In the accompanying drawings I have shown how my said invention may be conveniently and advantageously carried into practice.

Figure 1 is a vertical central section of one form of my improved disappearing turret, the gun and other parts being shown in side elevation. Fig. 2 is a vertical central section on the line $x x$, Fig. 1, some of the parts being shown in rear elevation. Fig. 3 is a rear elevation, partly in vertical central section, drawn to an enlarged scale, showing details of construction. Fig. 4 is a vertical central section of another form or modification of my improved turret, the gun and other parts being shown in side elevation. Fig. 5 is a section on the line $x' x'$, Fig. 4, some of the parts being shown in rear elevation. Fig. 6 is a vertical central section, drawn to an enlarged

scale, showing a further slight modification of my invention.

Like letters indicate corresponding parts throughout the drawings.

A is the turret, which is sunk in a pit, and is protected by an armored shield B, surrounded by a thick course B' of stone-work or concrete.

C is the gun.

The turret comprises a vertically-movable and rotating portion and another portion which, though it rotates therewith, does not participate in the up-and-down movement thereof. The said vertically-movable portion comprises a platform a , upon which is mounted the cylindrical casing or wall b . This casing or wall supports an armored spherical roof or cupola c , having a cylindrical portion c' . In this cylindrical portion is formed the port-hole or embrasure d , through which the gun is fired.

The gun is mounted in a cradle or top carriage e , arranged to recoil upon a chassis, slide, or beam f , pivoted at f' to a bracket g , secured to the wall b of the turret. The said chassis, slide, or beam is supported at its rear end by a forked rod h , formed in three parts or pieces, the central portion h' having right and left hand screw-threads, which fit into correspondingly-screw-threaded holes in the upper and lower parts of the said rod h . The part h' is, moreover, provided with a hand-wheel h^2 for rotating or adjusting the same to elevate or depress the gun by turning the chassis, slide, or beam about its pivot f' . The gun may, however, be mounted in any other suitable form of carriage that will permit of its withdrawal into the turret.

The vertically-movable portion of the turret, comprising the platform a , casing b , and cupola c , can be lowered until the said cupola rests upon the shield B. The lowering or disappearing of the turret is controlled by means of a special arrangement of hydraulic cylinders and springs hereinafter described.

The vertically-movable part of the turret is surrounded by a casing i , of sheet metal, which is carried by a ring or annular piece j and forms therewith the other portion of the turret, which is capable of rotation, but has

no vertical movement. The ring j is formed with an annular groove or channel j' , and is supported through the medium of spherical rollers or balls k upon a racer or roller path l , attached to the masonry or wall of the pit. The racer l is provided with an internally-toothed ring l' , with which is geared a toothed wheel m , mounted on a vertical spindle m' , carried in suitable bearings m^2 . The shaft m' has fixed thereon a miter-wheel m^3 , which is geared with another miter-wheel m^4 , fixed upon a horizontal spindle m^5 , carried in suitable bearings and provided with a hand-wheel m^6 . By rotating the said hand-wheel the turret may be turned about its axis to train the gun. To insure the turning of the wheel m with its shaft, notwithstanding the vertical movement of the parts $a b c$ of the turret, the said shaft m' is so arranged that it can move up and down in the boss of the toothed wheel m , and is provided with a long groove or keyway m^7 , in which fits a corresponding key or feather in the said boss, so that the said shaft, while free to slide in the said toothed wheel, is rotatively connected therewith; or the spindle m' may be provided with a long key or feather fitting into a corresponding keyway in the boss of the toothed wheel m .

The vertically-movable portion of the turret is guided within the casing i by means of rollers n , and is supported by the ram o of a hydraulic cylinder p . This cylinder is carried by two girders q , forming part of or firmly attached to the ring or annular piece j , and the said cylinder communicates with a second cylinder r , of larger diameter, in which works a ram s . The communication between the cylinders $p r$ is regulated or controlled by means of a valve p' , which is operated by means of a rod or stem p^2 , carried by a bracket or standard p^3 and provided with a hand-wheel p^4 . The ram s is firmly connected with a cross-piece t , which is suspended by side rods t' from other cross-pieces t^2 , resting upon springs u , mounted on rods v . The said ram acts through the said cross-pieces $t t^2$ and rods t' upon the said springs u . The cross-piece t is guided by sleeves t^3 , passing freely over the springs u .

The rods v are provided at their upper extremities with screw-threaded portions which extend through correspondingly-screw-threaded holes in toothed or worm wheels w . These toothed or worm wheels are supported by a cross-piece w' , formed on the cylinder p or firmly attached to the girders q .

The toothed or worm wheels w are operated by means of a horizontal shaft y , having fixed thereon toothed or worm wheels y' , geared with the wheels w . The shaft y is driven by a vertical shaft z , carried in suitable bearings and connected by bevel-pinions with the said shaft y and with a hand-wheel z' , situated within reach of the gunner. Any other suitable means may, however, be employed for increasing or diminishing the compression of the springs u .

The rod or stem p^2 for operating the communication-valve p' is formed in two parts, one of which is provided with a socket p^5 , in which slides the other part p^6 , so that the two parts will be connected notwithstanding the up-and-down movement of the vertically-movable portion of the turret. To insure the turning of the two parts of the said rod together, the lower part p^6 is provided with a suitable key or feather adapted to fit in a corresponding groove or keyway in the said socket p^5 , or the said lower part p^6 is made square or of other suitable form in transverse section and arranged to slide in a correspondingly-shaped socket on the upper part.

To prevent the descent of the vertically-movable portion of the turret before the gun is completely within the same, I provide an arm or projection f^2 on the forward end of the top carriage e . This arm bears against a lever f^3 , pivoted at f^4 to lugs f^5 , attached to the wall of the turret. Against the lever f^3 bears a spring f^6 , and the said lever is connected by means of a rod or link f^7 to a lever f^8 , pivoted at f^9 to lugs p^7 upon the bracket or standard p^3 . The upper extremity of the lever f^8 serves as a stop-pawl and is adapted to engage with the teeth of a ratchet-wheel p^8 , fixed upon the rod or stem p^2 , (whereby the valve p' is opened or closed,) and thus prevent the operation of the said rod. When the gun, after firing, is withdrawn into the turret by the recoil or otherwise, the arm or projection f^2 being moved away from the lever f^3 allows the spring f^6 to move the said lever, the connecting-rod f^7 , and the lever f^8 , so as to disengage the pawl from the ratchet-wheel p^8 , and thus permit the opening of the valve p' by means of the hand-wheel p^4 .

The operation of the apparatus above described is as follows—that is, to say: When the gun is fired it recoils with the top-carriage e along the beam f until the whole of the gun is within the turret. Communication may then be established between the cylinders p and r by opening the valve p' . When the said cylinders are thus put in communication with each other, the weight of the vertically-movable portion of the turret causes the same to descend, the ram o forcing the liquid from the cylinder p into the cylinder r . The ram s and cross-piece t are thus forced downward and through the medium of the rods t' and cross-pieces t^2 compress the springs u . When it is desired to raise the turret, the toothed wheels w are rotated by means of the hand-gear above described in the proper direction to raise the rods or stems v , and thus cause the same to act through the medium of the springs u , the cross-pieces $t t^2$, and the rods t' upon the ram s . This ram rising in the cylinder r forces the liquid back into the cylinder p , and thus raises the turret. The valve p' is then closed, and the springs u are slackened or their initial compression diminished by rotating the wheels w in the reverse direction, so as to permit the disappearance or

descent of the turret when the said valve is again opened. If the springs *u* are slackened previous to the opening of the valve *p'* for communication between the cylinders *p* and *r*, but slight resistance will be offered to the descent of the turret, which will consequently disappear suddenly. If, on the contrary, the said springs have more or less initial compression the turret will meet with increased resistance, and will descend or disappear more slowly, according to the degree of such initial compression. The turret can, moreover, be caused to rise or appear slowly or suddenly, as may be desired, the speed of rotation of the hand-wheel *z'* being varied as may be required for this purpose.

Figs. 4 and 5 illustrate a modification of my invention, wherein the casing *i*, of plate or sheet metal, which surrounds the vertically-movable part of the turret, is secured to the pit-wall. Between the casing *i* and the part *b* are placed spherical rollers or balls *n*. The turret is supported upon a ram formed in two parts *o'* *o''*. The part *o''* rotates with the turret; but the part *o'* does not rotate. The cylinder *p* is supported by beams or girders *q*, which are in this case fixed in the pit-wall instead of being attached to the revolving portion of the turret, as in the arrangement hereinbefore described. From the said cylinder *p* extends a pipe *p''*, which is provided with a valve *p'* and which affords communication between the said cylinder and the cylinder *r*, the said cylinder *r* being in this case formed on or attached to a bracket *r'*, fixed in a base-chamber or lateral gallery *D* of the pit. As in the arrangement hereinbefore described, the liquid forced out of the cylinder *p* by the ram *o'* enters the cylinder *r* and forces out the ram *s* and acts through the said ram *s* upon a cross-piece *t*, thus compressing the springs *u*. By means of a hand-wheel *z'* and a screw-threaded extension *s'* of the ram *s*, working in a nut *z''*, which forms part of the said hand-wheel and is fitted to rotate in the cross-piece *t*, the ram *s* can be forced inward and the turret returned to its fighting position. This arrangement also admits of the turret being lowered or disappearing suddenly or gradually by adjusting the initial compression of the springs in the manner hereinbefore described. The rods *v* are in this case connected directly to the cross-piece *t*. The valve *p'* for controlling the communication between the cylinders *p* and *r* is worked by means of a stem or rod *p''*, passing through the center of the ram *o'* *o''* and arranged to be operated from the platform *a* by means of the hand-wheel *p''*.

I sometimes provide for operating the valve *p'* from below by means of a hand-wheel *p''*, as shown in Fig. 6. A safety device similar to that hereinbefore described or of other suitable construction is, moreover, provided for preventing the lowering of the vertically-movable portion of the turret before the gun is drawn into the same. The vertically-mov-

able portion of the turret is rotated by means of the hand-wheel *m''*, spindle *m'*, toothed wheel *m*, and toothed ring *l'*, substantially as hereinbefore described.

Suitable gearing should be provided for moving the top carriage *e* on the slide *f* by hand, so that the gun may, if desired, be drawn into the turret without firing it.

What I claim is—

1. The combination, with a disappearing turret, of turret-elevating mechanism acting to raise the said turret from the loading to the firing position, a turret-upholding device acting to retain the said turret in the firing position when thus raised, an adjustable spring for supporting the turret, located between the said mechanism and the turret, whereby the descent of the said turret is regulated, and connecting devices between the said spring and the turret-elevating mechanism, whereby the said mechanism when operated in one direction will, through the medium of the said spring, raise the turret, and when operated in the reverse direction while the turret is upheld will diminish the compression of the said spring, so as to permit the more or less rapid descent of the turret when released, substantially as described.

2. The combination, with a disappearing turret, of a turret-supporting spring, whereby the descent of the said turret is regulated, turret-elevating mechanism comprising a screw and nut, one of which is capable of and the other of which is restrained from endwise or longitudinal movement, connecting devices between the longitudinally-movable part of the said mechanism and the said turret-supporting spring, whereby when the said mechanism is operated in one direction it will, through the medium of the said spring, raise the turret, and a turret-upholding device whereby the turret when raised is held up to permit the operation of the said mechanism in the reverse direction to adjust the said spring and thus regulate the descent of the turret, for the purpose above specified.

3. The combination, with a disappearing turret, of elevating mechanism therefor, comprising a spring for regulating the descent of the turret, hydraulic cylinders which are in communication with each other through a pipe or passage and the ram of one of which supports the turret, the ram of the other being connected with the said spring, and a valve or its equivalent whereby the said pipe or passage may be closed for the purpose of holding up the turret while the elevating mechanism is operated to permit the reaction of the said spring to a greater or less extent, for the purposes above specified.

4. The combination, with a disappearing turret, of a hydraulic cylinder the ram of which supports the said turret, another hydraulic cylinder communicating with the first by means of a pipe or passage, a valve for controlling the flow of liquid through the said pipe or passage, screw-gearing for elevating

the said turret by the movement of the ram of the second hydraulic cylinder, and an elastic or spring connection between the said ram and the screw-gearing, substantially as and for the purposes set forth.

5. The combination, with a disappearing turret, of two hydraulic cylinders in communication with each other, the ram of one of the said cylinders supporting the said turret, a spring whereby the ram of the other cylinder is loaded, a valve for controlling the flow of liquid from one to the other of the said cylinders, and means, substantially such as above described, for varying the compression of the said spring, substantially as and for the purposes set forth.

6. The combination, with a disappearing turret having a port-hole or embrasure, of a gun adapted to protrude through the said embrasure, a slide carried by the turret and upon which the gun is run in and out, and a retaining device which holds up the turret when elevated and the operation of which to release the turret is prevented by the gun when run out, for the purpose above specified.

7. The combination, with a disappearing turret having a port-hole or embrasure, of a beam or slide which is pivoted to the turret beneath the said embrasure and upon which the gun is run in and out, elevating-gear connected with the said slide for turning the same about its pivot, and a retaining device which holds up the turret when elevated and the operation of which to release the turret is prevented by the gun when run out, substantially as and for the purposes set forth.

8. The combination, with a disappearing turret having a port-hole or embrasure, of a beam or slide which is pivoted to the turret beneath the said embrasure and upon which the gun is run in and out, elevating-gear connected with the said slide for turning the same about its pivot, and elevating mechanism for raising and lowering the turret and compris-

ing hydraulic cylinders communicating with each other and a valve which controls such communication and which is kept closed by the gun when run out, substantially as and for the purposes set forth.

9. The combination, with the vertically-movable portion of the turret and the elevating mechanism therefor, of a metal casing surrounding the same, a fixed roller-path on which the said casing is supported through the medium of rollers, anti-friction rollers situated between the said casing and the periphery of the said vertically-movable portion, a circular rack formed or fixed on the said roller-path, a pinion geared with the said rack, turning mechanism carried by the said vertically-movable portion, and a device which rotatively connects the said mechanism with the pinion while permitting it to move up and down relatively thereto, substantially as and for the purposes set forth.

10. The combination, with the disappearing turret, of the hydraulic cylinder *p*, the ram *o* of which supports the turret, the hydraulic cylinder *r*, the cross-piece *t*, connected with the ram *s* thereof, the springs *u*, connected with the said cross-head *t*, screw-threaded rods *v*, extending through the said springs, means, substantially such as above described, for imparting movement to the said ram *s* through the said cross-head *t*, springs *u*, and rods *v*, a pipe or passage connecting the said hydraulic cylinders, and valve mechanism for controlling the flow of liquid through the said pipe or passage, substantially as and for the purposes set forth.

In testimony whereof I have hereunto signed my name in the presence of two subscribing witnesses.

JEAN BAPTISTE GUSTAVE ADOLPHE CANET.

Witnesses:

J. L. RATHBONE,
R. J. PRESTON.