

(19) World Intellectual Property Organization
International Bureau



(43) International Publication Date
25 February 2010 (25.02.2010)

(10) International Publication Number
WO 2010/020951 A1

(51) International Patent Classification:

B25C 1/02 (2006.01) *F16B 15/00* (2006.01)
B25C 5/02 (2006.01) *F16B 15/02* (2006.01)

(21) International Application Number:

PCT/IB2009/053654

(22) International Filing Date:

19 August 2009 (19.08.2009)

(25) Filing Language:

English

(26) Publication Language:

English

(30) Priority Data:

61/136,222 19 August 2008 (19.08.2008) US

(71) Applicant and

(72) Inventor: **DAVIDOVITCH, Yaakov Zvi** [IL/IL]; 5 Aba Achimeir Str., 52587 Ramat-Gan (IL).

(74) Agents: **Dr. D. GRAESER LTD.** et al.; 13 HaSadna St., P.O.Box 2496, 43650 Raanana (IL).

(81) Designated States (unless otherwise indicated, for every kind of national protection available): AE, AG, AL, AM, AO, AT, AU, AZ, BA, BB, BG, BH, BR, BW, BY, BZ, CA, CH, CL, CN, CO, CR, CU, CZ, DE, DK, DM, DO,

DZ, EC, EE, EG, ES, FI, GB, GD, GE, GH, GM, GT, HN, HR, HU, ID, IL, IN, IS, JP, KE, KG, KM, KN, KP, KR, KZ, LA, LC, LK, LR, LS, LT, LU, LY, MA, MD, ME, MG, MK, MN, MW, MX, MY, MZ, NA, NG, NI, NO, NZ, OM, PE, PG, PH, PL, PT, RO, RS, RU, SC, SD, SE, SG, SK, SL, SM, ST, SV, SY, TJ, TM, TN, TR, TT, TZ, UA, UG, US, UZ, VC, VN, ZA, ZM, ZW.

(84) Designated States (unless otherwise indicated, for every kind of regional protection available): ARIPO (BW, GH, GM, KE, LS, MW, MZ, NA, SD, SL, SZ, TZ, UG, ZM, ZW), Eurasian (AM, AZ, BY, KG, KZ, MD, RU, TJ, TM), European (AT, BE, BG, CH, CY, CZ, DE, DK, EE, ES, FI, FR, GB, GR, HR, HU, IE, IS, IT, LT, LU, LV, MC, MK, MT, NL, NO, PL, PT, RO, SE, SI, SK, SM, TR), OAPI (BF, BJ, CF, CG, CI, CM, GA, GN, GQ, GW, ML, MR, NE, SN, TD, TG).

Published:

- with international search report (Art. 21(3))
- before the expiration of the time limit for amending the claims and to be republished in the event of receipt of amendments (Rule 48.2(h))

(54) Title: A MULTIPLE LEGGED NAIL AND MULTIPLE LEGGED NAIL INSERTION DEVICE

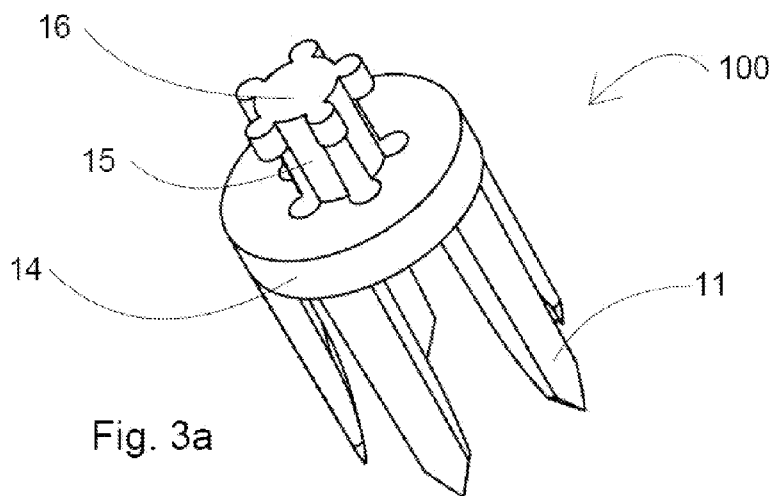

Fig. 3a

(57) Abstract: A multiple legged nail (100) whose legs (11) are shaped with slopes (13) which ensure that when inserted into a panel, such as a wood or plaster panel, the legs (11) will bend outwards in order to achieve good grip of the panel, while keeping the head (16) of the nail at the desired angle with the panel, and a multiple legged nail insertion device (200), which includes a handle (24), a cylindrical guide (23), and an internal hammer, and which enables the insertion of multiple legged nail (100), with ease and precision, and without incurring any damage to it. Optionally the multiple legged nail (100) has a shoulder disc (14) having two planes to which the legs are attached on the first plane, in which the shoulder disc (14) is conical on the second plane. A plurality of such nails may optionally support a plate (1000), for example by being inserted through holes in said plate.



WO 2010/020951 A1

A Multiple Legged Nail and Multiple Legged Nail Insertion Device

FIELD OF THE INVENTION

The present invention relates to nails, more particularly, to a multiple legged nail
5 and to a multiple legged nail insertion device.

BACKGROUND OF THE INVENTION

Panels made of various materials such as wood or plaster, (AKA drywall) are commonly used for various purposes such as building structures. Often such panels
10 need to be connected to each other, and one of the common ways of doing this is by means of nails. Furthermore, there is also a need to hang various objects such as pictures, cabinets, and shelves and to connect various items to such panels, for example paper notes. Other than nails, thumbtacks and screws, screwed into dowel anchors inserted into drill holes in walls, also serve for these purposes.

15 The internal structure of plaster panels and panels that are not uniform in structure, such as fibrous wood panels, often cause nails to shift from the desired direction when being inserted.

Figure 1a of the prior art is a side view schematic illustration of the standard practice of inserting a nail into a wood panel, with the nail held in one hand and a
20 hammer to hit the head of the nail held in the other hand. Figure 1b of the prior art depicts how a regular nail might bend due to a slight deviation of the axis of force from the hit by the hammer with regard to the nail's axis.

When the material into which the nail is inserted is too soft, e.g. chipboard or plaster, the nail's grip in that material is very loose. This may be the case also when a
25 screw is screwed into a soft material. Dowel anchors may solve this problem in case of plaster, for example, but on the expense of higher handling complexity. It also does not provide a complete, strong solution.

When a nail is inserted into a plate bundle the plates tend to detach over time. When such plates are connected by means of a screw the screw length is selected such
30 that its tip would be within the last plate. An insufficiently long screw wouldn't attach to the last layer, as depicted in Figure 1c, while a screw that is too long protrudes out from the last layer, as depicted in Figure 1d.

There is thus a widely recognized need for, and it would be highly advantageous to have a new nail and an insertion device to replace nails, screws and

thumbtacks that are presently in use without requiring any special skills of the user, and without facing the above list of drawbacks.

The prior art does not teach or suggest such a solution.

5 SUMMARY OF THE INVENTION

 A multiple legged nail and multiple legged nail system according to at least some embodiments of the present invention includes a multiple legged nail, with the shape of the legs ensuring that when inserted into a panel such as a wood or plaster panel, in which the legs optionally bend outwards, inwards, or a combination of
10 inwards and outwards.

 A good grip of the board is thus achieved while keeping the nail at the desired angle relative to the panel.

 The multiple legged nail insertion device enables insertion of the multiple legged nail with ease and precision, and without incurring damage to the nail.

15 The nail and insertion device ensure perpendicular insertion of the multiple legged nail insertion to a plate without bending of the nail before and during the insertion. A tight grip is ensured even if the plate or wall is made of a soft material or of multiple layers. The nail's length is not critical even in case of a plate bundle because any excess length can be easily bent backward toward the back side of the
20 last plate, an operation that would also enhance the grip strength of the nail.

 Additional details and advantages of the invention will be set forth in part in the description which follows and, in part, will be obvious from the description, or may be learned by practice of the invention.

25 BRIEF DESCRIPTION OF THE DRAWINGS

 The invention is herein described, by way of example only, with reference to the accompanying drawings, wherein:

 Figure 1a of the prior art is a side view schematic illustration of the standard practice of inserting a nail into a wood panel.

30 Figure 1b of the prior art depicts how a regular nail might bend due to a slight deviation of the axis of force from the hit by the hammer with regard to the nail's axis.

 Figure 1c of the prior art depicts a case of a multiple layer plate or board where the last layer is not attached to the other layers when the screw length is too short.

Figure 1d of the prior art depicts a case of a multiple layer plate or board where a screw that is too long protrudes from the last layer.

Figure 2a is a lower isometric view illustration of an illustrative, exemplary embodiment of a multiple legged nail and multiple legged nail insertion device
5 system, according to the present invention

Figure 2b is an upper isometric view illustration of an illustrative, exemplary embodiment of a multiple legged nail and multiple legged nail insertion device system, according to the present invention upon which the section plane 7a-7a is marked.

10 Figure 3a is an upper isometric view illustration of an illustrative, exemplary embodiment of a multiple legged nail, according to the present invention.

Figure 3b is a bottom view illustration of an illustrative, exemplary embodiment of a multiple legged nail, according to the present invention.

15 Figure 3c is a side view illustration of an illustrative, exemplary embodiment of a multiple legged nail, according to the present invention.

Figure 3d is a top view illustration of an illustrative, exemplary embodiment of a multiple legged nail, according to the present invention.

Figure 3e is a side view illustration of an illustrative, exemplary embodiment of two legs, according to the present invention.

20 Figure 4a is a bottom view illustration of an illustrative, exemplary embodiment of a handle, according to the present invention.

Figure 4b is a part of cross sectional view 7a-7a illustration of an illustrative, exemplary embodiment of the handle, according to the present invention.

25 Figure 5a is a bottom view illustration of an illustrative, exemplary embodiment of a cylindrical guide, according to the present invention.

Figure 5b is a part of cross sectional view 7a-7a illustration of an illustrative, exemplary embodiment of the cylindrical guide, according to the present invention.

Figure 5c is an upper isometric view illustration of an illustrative, exemplary embodiment of the cylindrical guide, according to the present invention.

30 Figure 6a is a bottom view illustration of an illustrative, exemplary embodiment of an internal hammer, according to the present invention.

Figure 6b is a part of cross sectional view 7a-7a illustration of an illustrative, exemplary embodiment of the internal hammer, according to the present invention.

Figure 6c is an upper isometric view illustration of an illustrative, exemplary embodiment of the internal hammer, according to the present invention.

Figure 7a is a cross sectional view 7a-7a illustration of an illustrative, exemplary embodiment of a multiple legged nail and multiple legged nail insertion device system, according to the present invention, upon which detail A is marked in a circle, and detail B is marked in an oval.

Figure 8 illustrates an option for bending the protruding leg tips of multiple legged nail back.

Figure 9 illustrates another optional embodiment of a multiple legged nail according to the present invention for use with a plate or other support.

Figure 10 shows the nail of Figure 9 in an exemplary, illustrative use thereof.

Figure 11 shows a cross-section of the nail of Figure 9 in an exemplary, illustrative use thereof.

15 DETAILED DESCRIPTION OF EMBODIMENTS

The principles and operation of a multiple legged nail and of a multiple legged nail system according to the present invention may be better understood with reference to the drawings and the accompanying description.

Before explaining at least one embodiment of the invention in detail, it is to be understood that the invention is not limited in its application to the details of construction and the arrangement of the components set forth in the following description or illustrated in the drawings.

Unless otherwise defined, all technical and scientific terms used herein have the same meaning as commonly understood by one of ordinary skill in the art to which this invention belongs. The materials, dimensions, methods, and examples provided herein are illustrative only and are not intended to be limiting.

The following list is a legend of the numbering of the application illustrations:

11	leg
11o	leg outer side
30 11i	leg inner side
12	leg tip
13	leg slope
14	shoulder disc

	14a	cut cone
	15	neck
	16	head
	17	hole
5	18	jag
	22	internal hammer
	22a	peripheral gradation
	22b	outer flexible cylinder
	22c	peripheral teeth
10	23	cylindrical guide
	24	handle
	24a	first peripheral niche
	24b	second peripheral niche
	25	auxiliary rigid shim
15	30	plate
	100	multiple legged nail
	200	multiple legged nail insertion device
	300	multiple legged nail and multiple legged nail insertion device system

Referring now to the drawings, Figure 2a is a lower isometric view illustration of an illustrative, exemplary embodiment of a multiple legged nail and multiple legged nail insertion device system **300**, according to the present invention.

The present illustration shows a multiple legged nail **100**, shown partially within a multiple legged nail insertion device **200**.

Figure 2b is an upper isometric view illustration of an illustrative, exemplary embodiment of a multiple legged nail and multiple legged nail insertion device system **300**, according to the present invention, upon which the section plane 7a-7a is marked.

The present illustration shows a multiple legged nail **100**, which is partially within a multiple legged nail insertion device **200**.

Figure 3a is an upper isometric view illustration of an illustrative, exemplary embodiment of a multiple legged nail **100**, according to the present invention.

The multiple legged nail **100** can be a single unit composed of materials such as plastic, soft metal, or a combination thereof, or any other material which enables leg **11** to bend when being inserted into a board, as will be described in the following

description of Figure 3e. Legs **11** may optionally be finished with any type of finishing surface and/or material, including but not limited to polished, roughened, knurled or any suitable coating.

5 All the legs **11** protrude from one side of a shoulder disc **14**. On the other side of the shoulder disc **14**, as shown in the present illustration, is optional neck **15** at the end of which is optional head **16**, a structure which enables hanging a load upon the multiple legged nail **100**. The multiple legged nail **100** also has the ability to withstand pulling forces, for example, it can hold a rectangle that has a cantilever beam sticking out from it.

10 The shoulder disc **14** also serves as the part of the multiple legged nail **100** which is hit by hammer (22) when performing insertion. When the purpose of multiple legged nail **100** is to connect panels or any such similar purpose, and when there is no need to hang a load upon it, a multiple legged nail **100** without neck **15** and head **16** can be used.

15 Head **16** can conform in shape and dimensions to a certain purpose, for example, head **16** can be smaller than a certain triangle that is often found in the back of pictures for hanging.

Figure 3b is a bottom view illustration of an illustrative, exemplary embodiment of a multiple legged nail **100**, according to the present invention. The present illustration shows a multiple legged nail **100** with five legs **11** all disposed upon the same circle, upon which they are equally distributed. This illustration does not in any way limit the present invention to a multiple legged nail **100** of necessarily five legs, as various numbers of legs are optionally used as long as at least a plurality of legs is used. For example, optionally at least two, preferably at least three, more preferably at least four and most preferably at least five legs are present.

20 The present illustration shows five holes **17**. These holes are meant to simplify the mold used in the manufacturing process of multiple legged nail **100**, since the extraction from the mold is only in two opposite directions and there are no undercuts, thus no need for a third and fourth direction of extraction of the mold. In cases in which multiple legged nail **100** is manufactured using a different method, there may be no holes **17**, or a different number of holes **17** for example according to the number of legs

30 Figure 3c is a side view illustration of an illustrative, exemplary embodiment of a multiple legged nail **100**, according to the present invention. Each leg **11** has a

pointed leg tip **12** which enables easy penetration into panels, and an adjacent leg slope **13** on the leg's inner side **11i**. Shoulder disc **14** has a thickness dimension marked in the present illustration as d_3 .

5 Figure 3d is a top view illustration of an illustrative, exemplary embodiment of a multiple legged nail **100**, according to the present invention.

The present illustration shows five jags **18**, on the perimeter of head **16**. Jags **18** are designated to hold something so it will not slip off (for example the rope in the back of a picture). Jags **18**, in their shape and quantity, are one possible embodiment of many for the shape of the perimeter of head **16**.

10 Figure 3e is a side view illustration of an illustrative, exemplary embodiment of legs **11**, according to the present invention. The upper part of the illustration shows leg **11** in its original form prior to being inserted into the board, while the middle part of the illustration shows leg **11** which has been deformed when inserted into the board. The deformation is bending towards the leg's outer side **11o**. This is a desired bend achieved as a result of a force component activated on the leg's inner side **11i** in
15 the area of leg slope **13** by plate **30**.

The lower part of the illustration shows leg **11** of a multiple legged nail **100** in its final bending state after being inserted into plate **30** (not shown in this part of the illustration).

20 Bending of leg **11** can be achieved in other directions, and particularly inwards, by manufacturing it with other suitable slopes.

Figure 4a is a bottom view illustration of an illustrative, exemplary embodiment of handle **24**, according to the present invention.

25 Figure 4b is a part of cross sectional view 7a-7a illustration of an illustrative, exemplary embodiment of the handle **24**, according to the present invention.

Handle **24** has an external shape designed for convenient holding in a person's hand. In the case described in the present illustration, the shape resembles that of a mushroom, which helps to prevent the user's fingers from being hit by the internal hammer (**22**).

30 Handle **24** optionally and preferably comprises an external cylinder of the multiple legged nail insertion device **200**, and it includes first peripheral niche **24a** which corresponds in shape and dimensions to the shape and dimensions of the cylindrical guide (**23**), not shown in the present illustration. In addition, handle **24** also includes a second peripheral niche **24b**, whose length is d_5 .

Figure 5a is a bottom view illustration of an illustrative, exemplary embodiment of cylindrical guide **23**, according to the present invention.

Figure 5b is a part of cross sectional view 7a-7a illustration of an illustrative, exemplary embodiment of cylindrical guide **23**, according to the present invention.

5 The overall length of cylindrical guide **23** is d_1 and its external shape and dimensions preferably correspond to the shape and dimensions of the handle **24**.

Figure 5c is an upper isometric view illustration of an illustrative, exemplary embodiment of the cylindrical guide **23**, according to the present invention.

10 Figure 6a is a bottom view illustration of an illustrative, exemplary embodiment of internal hammer **22**, according to the present invention.

Figure 6b is a part of cross sectional view 7a-7a illustration of an illustrative, exemplary embodiment of the internal hammer **22**, according to the present invention. Its right hand part, as shown in the present illustration, preferably has a constant external radius for its entire length, from the right end to the peripheral gradation **22a**.
15 Its length is d_2 , and it serves during the insertion of multiple legged nail **100** to conduct the necessary force from the shoulder disc (**14**) of the multiple legged nail **100**. On the other side, the left hand side as shown in the present illustration, of the internal hammer **22**, is outer cylinder **22b**, at whose right end, as shown in the present illustration, is a peripheral tooth **22c**, to engage with the second peripheral niche
20 (**24b**), and thus enable the limited linear movement of the internal hammer (**22**) relative to handle **24** whose length is equal to d_5 .

Figure 6c is a upper isometric view illustration of an illustrative, exemplary embodiment of the internal hammer **22**, according to the present invention.

25 Figure 7a is a cross sectional view 7a-7a illustration of an illustrative, exemplary embodiment of a multiple legged nail and multiple legged nail insertion device system **300**, according to the present invention.

The illustration marks detail A in a circle, which is magnified in the circle on figure 7b, and detail B in an oval, which is magnified in the circle on figure 7c, according to at least some embodiments of the present invention.

30 The present illustration shows a multiple legged nail **100**, partially within a multiple legged nail insertion device **200**, while its legs **11** protrude from the multiple legged nail insertion device **200**.

Multiple legged nail insertion device **200** also includes handle **24**, which is preferably cylindrical and comprises an external casing, in which is the internal

hammer **22**, which is partially within cylindrical guide **23** and which can move within in linear movement.

The view shown in the present illustration shows that the internal hammer **22** is preferably limited in movement to the right by the contact of its peripheral gradation **22a** at the end of cylindrical guide **23**.

The handle **24** can be made of soft material, such as rubber, while the cylindrical guide **23** and the internal hammer **22** are made of rigid materials, and are inserted in to handle **24** with force.

Figure 7b is a magnified detail A in a circle, according to at least some embodiments of the present invention. The formal structure and particularly the dimension ratios of the handle **24**, the cylindrical guide **23**, and the internal hammer **22** ensure that the right end, as shown in the view of the present illustration, of the internal hammer **22** cannot be in close proximity to the right end, as shown in the present illustration, of the handle **24**, as its diameter is smaller than d_3 , thus ensuring that the internal hammer **22** will not crush the shoulder disc **14** of the multiple legged nail **100** when there is contact between the shoulder disc **14** and the board into which it is inserted, at the end of the insertion process.

Figure 7c is a magnified detail B in an oval, according to at least some embodiments of the present invention. The present illustration shows one possible structure of various possibilities for the formal structure of the shoulder disc **14**. In this case, its right part, as shown in the present illustration, has a niche in the shape of cut cone **14a**.

The purpose of the cut cone **14a** is to conceal any gap between the nail and the wall that may have been formed in cases such as insertion at a slight angle or the wall is not completely straight.

Figure 8 illustrates a case where nail legs **11** are longer than the thickness of plate **30** into which multiple legged nail **100** is inserted. Multiple plates are depicted in the drawing as a general case. The protruding leg tips can be easily bent backward toward the rear surface of the plate bundle by either directly hitting them with a standard hammer or by using an auxiliary rigid shim **25** as a mediator between the hammer and the leg tips. This bending of the leg tips obviates the need for an accurate matching of the leg length and the plate thickness. The described bending also increase the strength of the resulting connection between the plates.

Rigid shim 25 may optionally have for example a square or a round shape, is optionally and preferably approximately a few mm in thickness and is optionally made of any rigid material - for example and without limitation, metal, wood or plastic.

5 Figure 9 illustrates another optional embodiment of a multiple legged nail according to the present invention with a conical head (shoulder disc). As shown, a multiple legged nail 900 optionally and preferably features a shoulder disc 902, to which a plurality of legs 11 are attached as previously described. Shoulder disc 902 preferably features a supporting surface 904, for example for being inserted through a
10 plate or other support. Shoulder disc 902 may optionally be conical as shown.

Figure 10 shows the nail of Figure 9 in an exemplary, illustrative use thereof. As shown a plurality of multiple legged nails 900 are preferably inserted through a plate 1000. Although four such multiple legged nails 900 are shown as being inserted through plate 1000, optionally any number of such nails 900 may be so inserted (ie 1,
15 2, 3, 4, 5, 6, 7 or 8, or more and so forth, optionally and preferably according to the load to be supported). Nails 900 are inserted through plate 1000 into a wall 1002 as previously described. Plate 1000 is shown in this non-limiting example as preferably supporting a bracket 1004, which in turn may optionally support any type of heavy load 1006.

20 Figure 11 shows a cross-section of the nail of Figure 9 in an exemplary, illustrative use thereof. As shown, a plurality of nails 900 are inserted through plate 1000 into wall 1002 as previously described. An arrow 1100 shows the direction of the load force.

25 Although the invention has been described in conjunction with specific embodiments thereof, it is evident that many alternatives, modifications and variations will be apparent to those skilled in the art. Accordingly, it is intended to embrace all such alternatives, modifications and variations that fall within the spirit and broad
30 scope of the appended claims.

It is specifically noteworthy that the shape and dimensions of the various components of the multiple legged nail (**100**) can be made to conform specifically for various designations, such as varying weights to be supported, composing materials, and the width of plate (**30**), into which it is supposed to be inserted. Thus, the number

of legs (**11**), their length, and the shapes and dimensions of the neck (**15**) and the head (**16**) can be changed as necessary.

WHAT IS CLAIMED IS:

1. A multiple legged nail comprising:
 - (a) a shoulder disc, having a first plane and a second plane; and
 - (b) at least two legs disposed on said first plane of said shoulder disc.
2. The multiple legged nail of claim 1, wherein each one of said at least two legs has a leg tip and a leg slope, said leg tip adapted for penetrating a material.
3. The multiple legged nail of claim 2, wherein said leg comprises a flexible material for enabling said leg to bend.
4. The multiple legged nail of claim 3, wherein said flexible material comprises one or more of plastic or metal, or a combination thereof.
5. The multiple legged nail of claim 4, wherein said leg is finished with a suitable finishing surface and/or material.
6. The multiple legged nail of claim 5, wherein said finishing surface is polished, knurled or roughened, or coated with a suitable coating.
7. The multiple legged nail of claim 2, wherein said legs are distributed equidistantly on said first plane of said shoulder disc.
8. The multiple legged nail of claim 7, further comprising at least one hook disposed on said second plane of said shoulder disc.
9. The multiple legged nail of claim 8, wherein said shoulder disc further comprises a cut cone.
10. The multiple legged nail of claim 2 further comprising:
 - (c) a neck disposed on said second plane of said shoulder disc.

11. The multiple legged nail of claim 10 further comprising:
- (d) a head disposed on said neck.
12. The multiple legged nail of claim 11, further comprising at least one jag on said head.
13. The multiple legged nail of claim 12, wherein said at least one jag comprises a plurality of jags.
14. The multiple legged nail of claim 1, wherein said second plane has a conical shape.
15. A multiple legged nail system comprising the multiple legged nail of claim 11 and further comprising a multiple legged nail insertion device comprising a static part for gripping said head and a movable part that is connected to said static part, wherein both said static and movable parts are centered around a longitudinal axis of said multiple legged nail, and wherein said movable part is adapted for applying force on said head along said common longitudinal axis.
16. The multiple legged nail system of claim 15 wherein said insertion device further comprises:
- (a) a cylindrical handle, said handle having a first peripheral niche and a second peripheral niche;
- (b) a cylindrical guide mounted partially inside said first peripheral niche of said handle; and
- (c) an internal hammer mounted partially inside said handle and partially inside said cylindrical guide.
17. The multiple legged nail system of claim 16, wherein said internal hammer has a peripheral gradation, and wherein said cylindrical guide, limits linear movement of said internal hammer inside said handle, when said peripheral gradation of said internal hammer comes in contact with said cylindrical guide.

18. A multiple legged nail support system, comprising a plurality of multiple legged nails according to any of claims 1-14; and a support for a load, said support comprising a plate, said plate comprising a plurality of holes for receiving said plurality of multiple legged nails.

19. A multiple legged nail insertion system for a standard hammer, comprising said multiple legged nail of claim 2 and an auxiliary rigid shim, said shim being adapted for use as a mediator between said standard hammer and the leg tips of said multiple legged nail, wherein said standard hammer is used for bending said tips backward toward a plate or a plate bundle into which said multiple legged nail has been inserted.

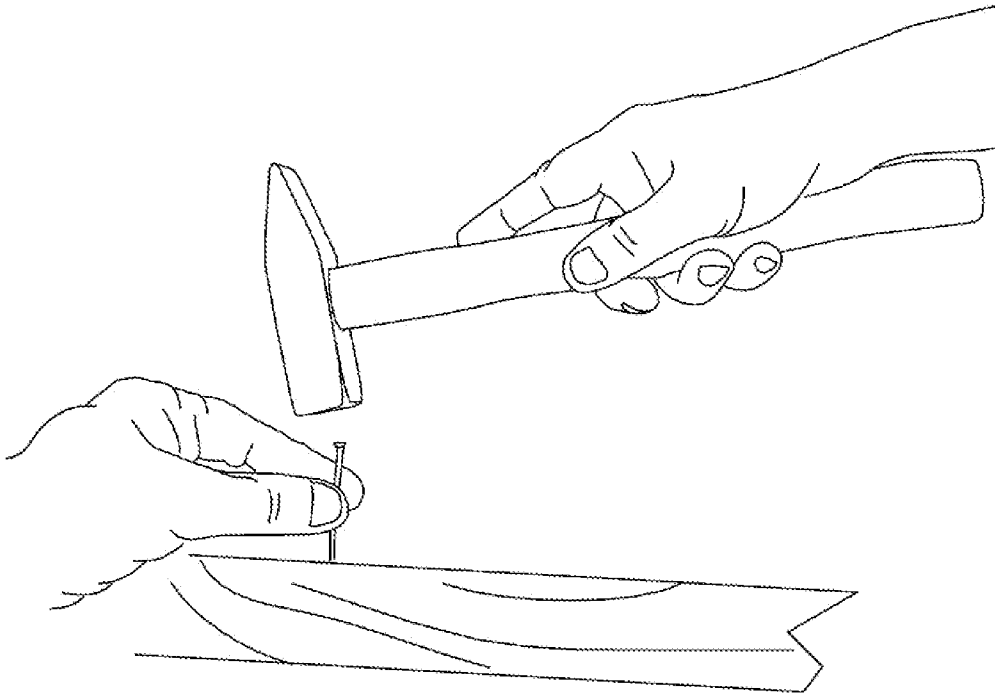

Figure 1a: PRIOR ART

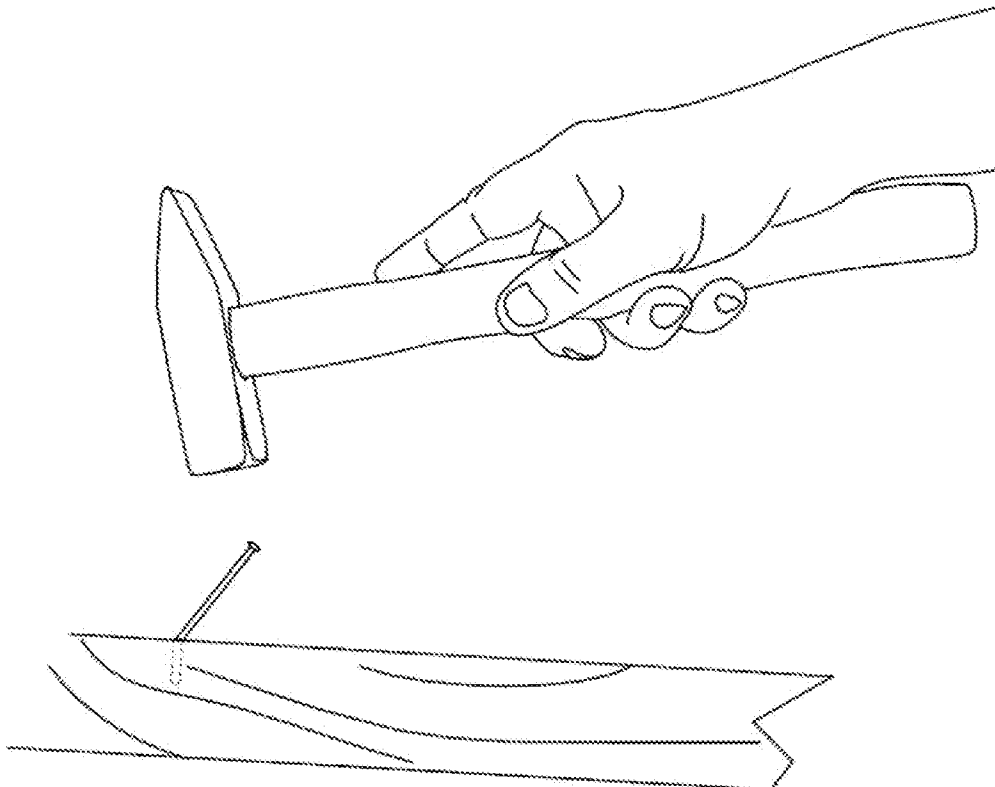

Fig 1b

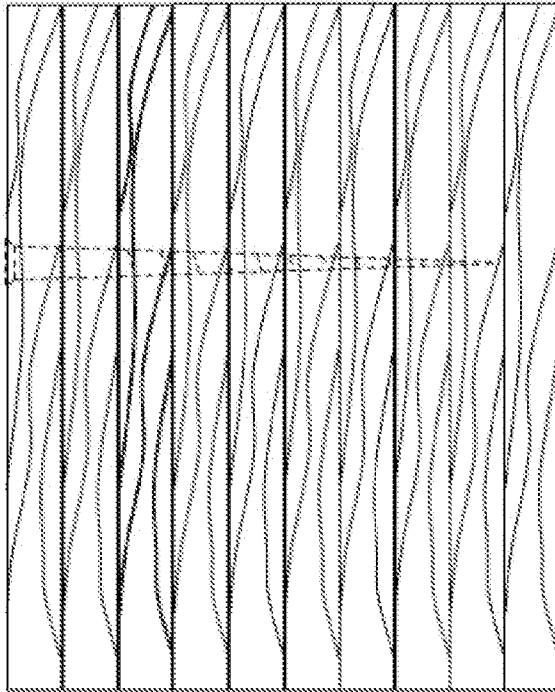

Fig. 1c

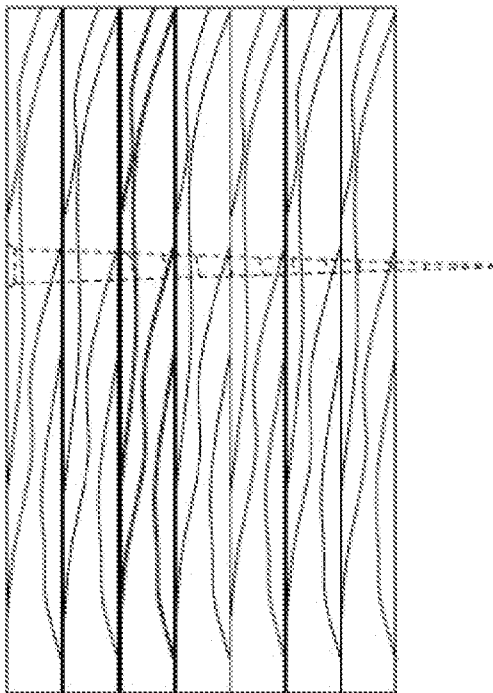

Fig 1d

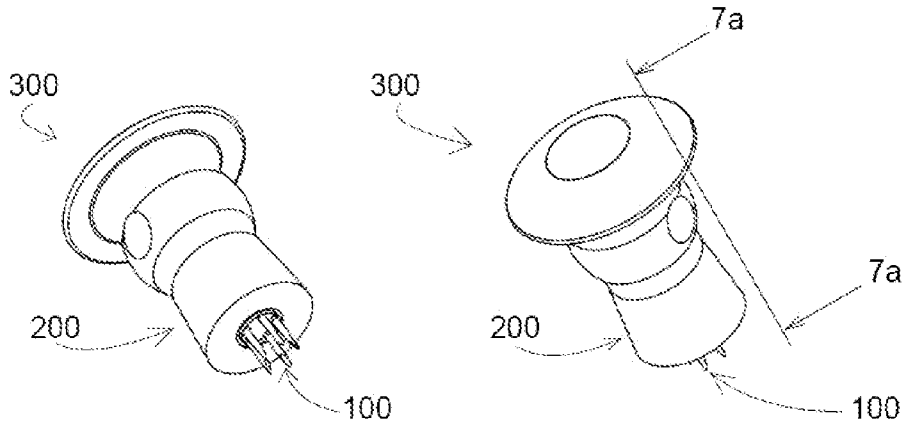

Fig. 2a

Fig. 2b

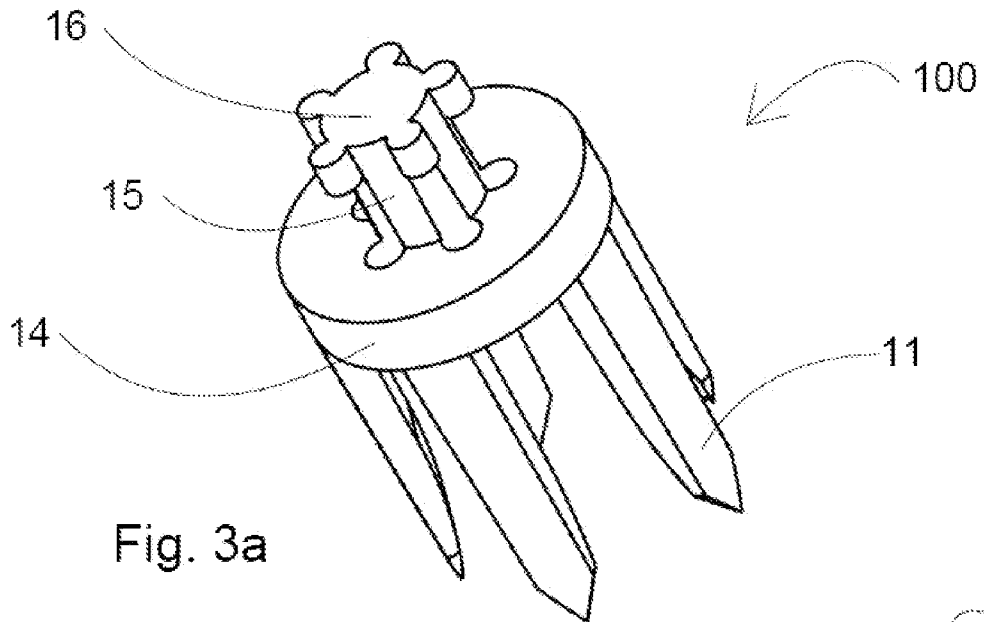

Fig. 3a

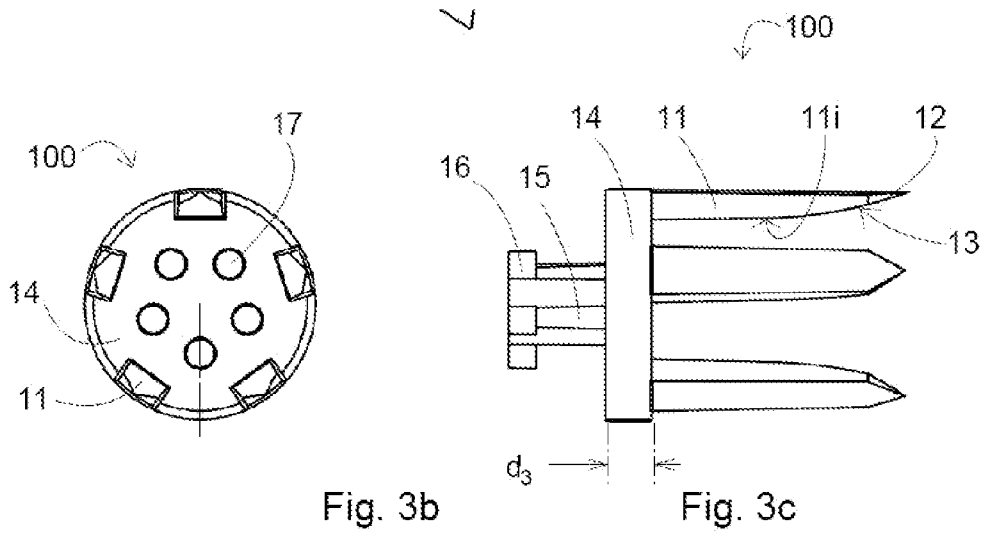

Fig. 3b

Fig. 3c

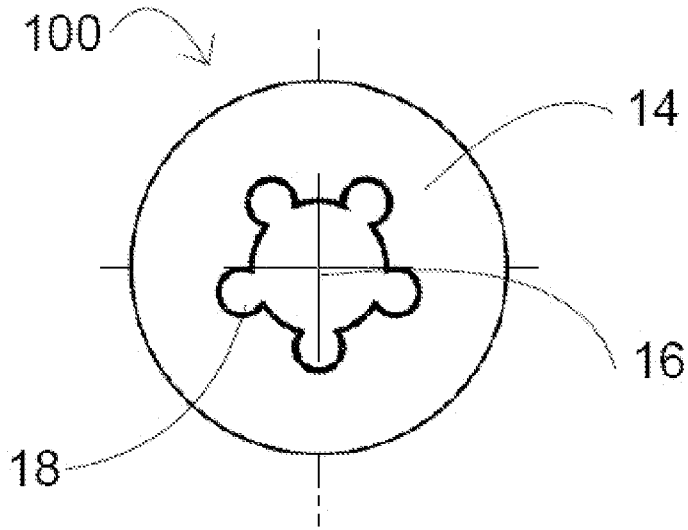

Fig. 3d

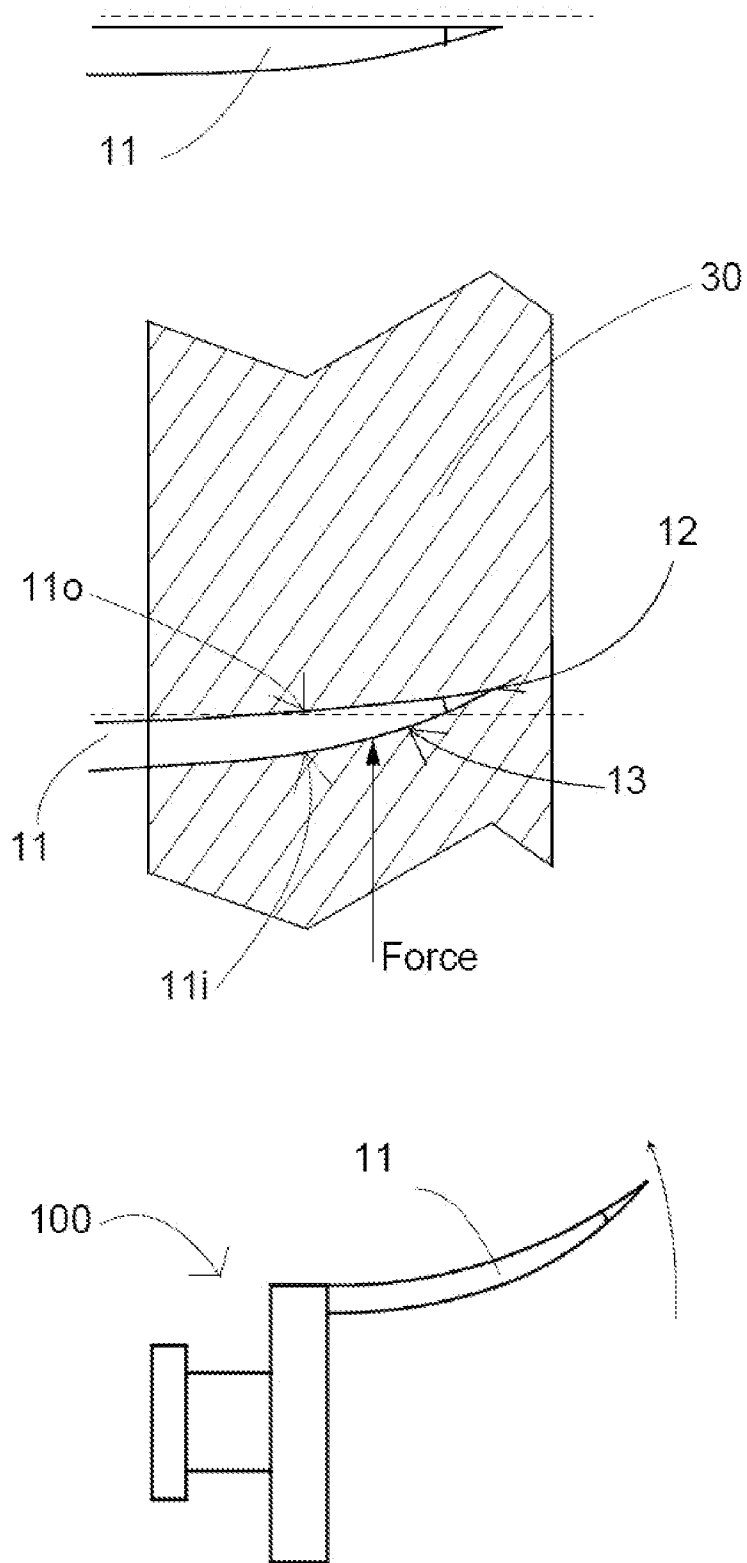

Fig. 3e

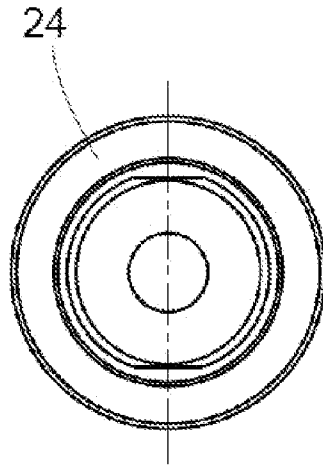

Fig. 4a

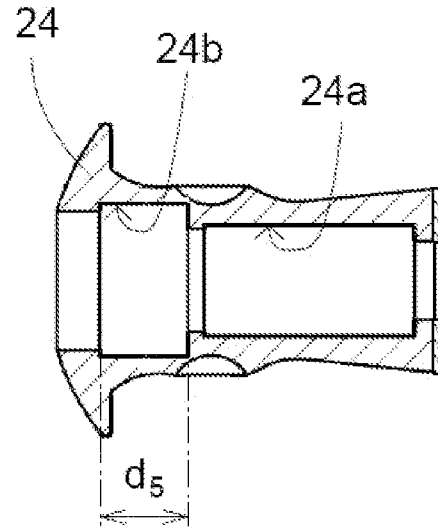

Fig. 4b

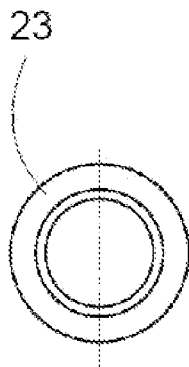

Fig. 5a

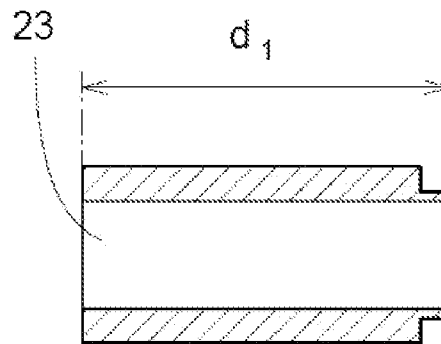

Fig. 5b

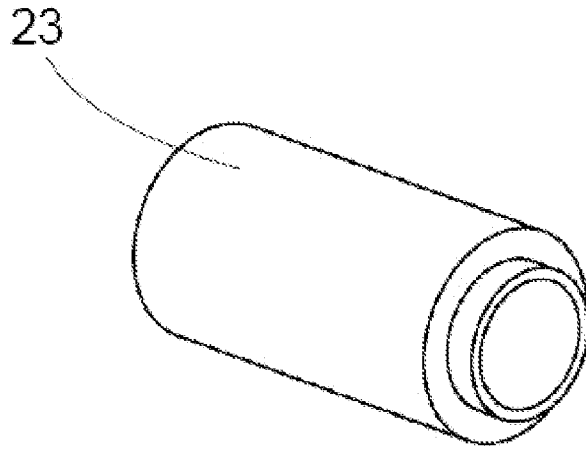

Fig. 5c

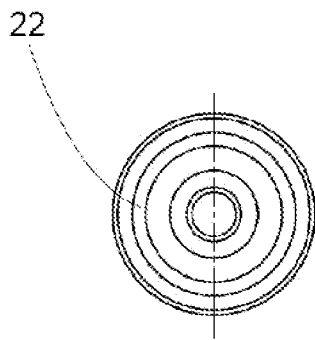

Fig. 6a

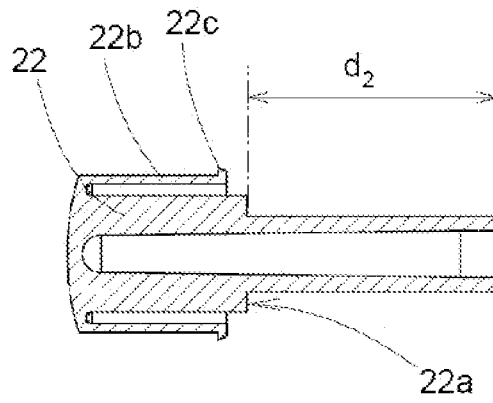

Fig. 6b

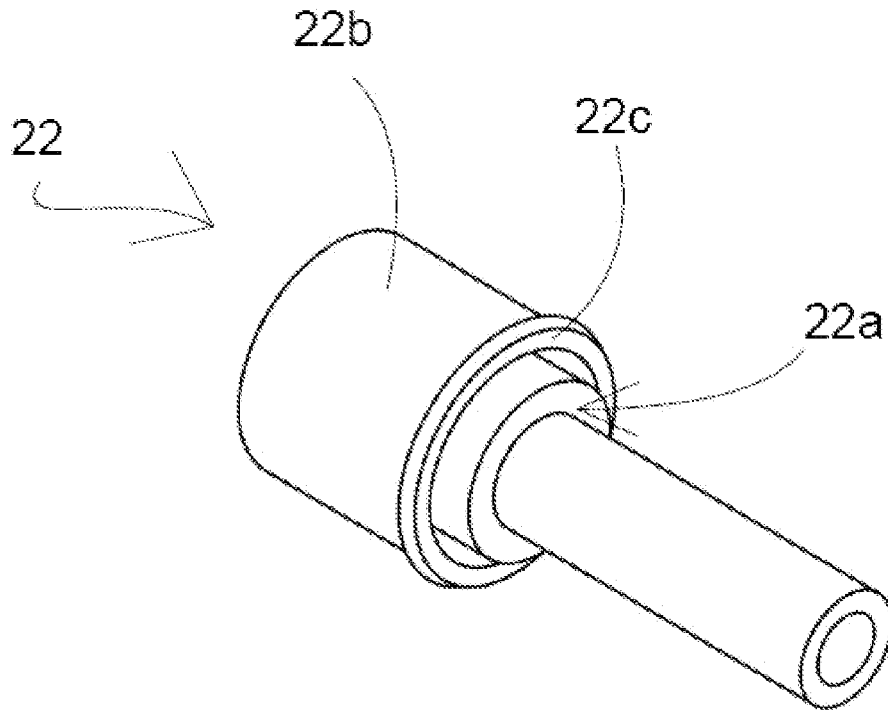

Fig. 6c

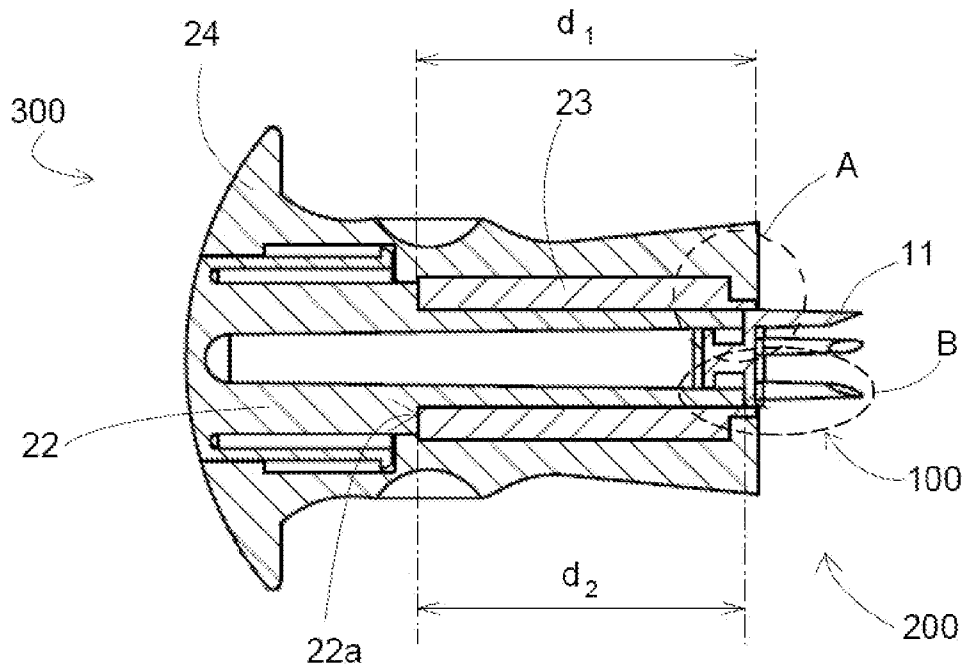

Fig. 7a

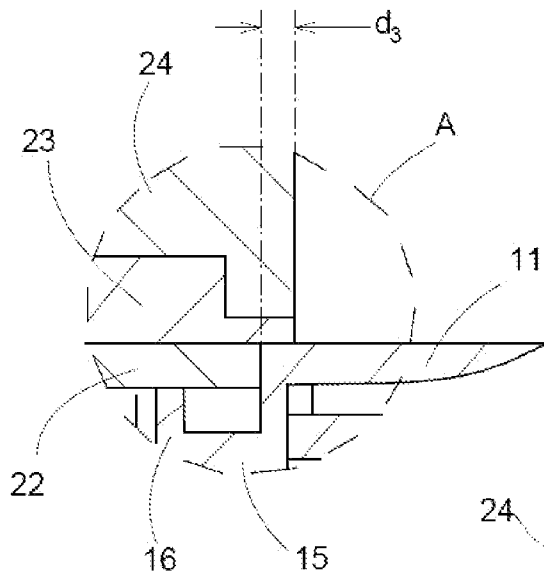

Fig. 7b

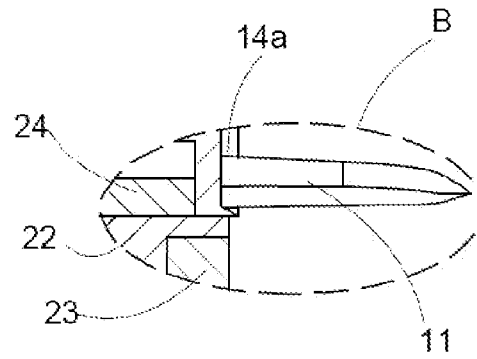

Fig. 7c

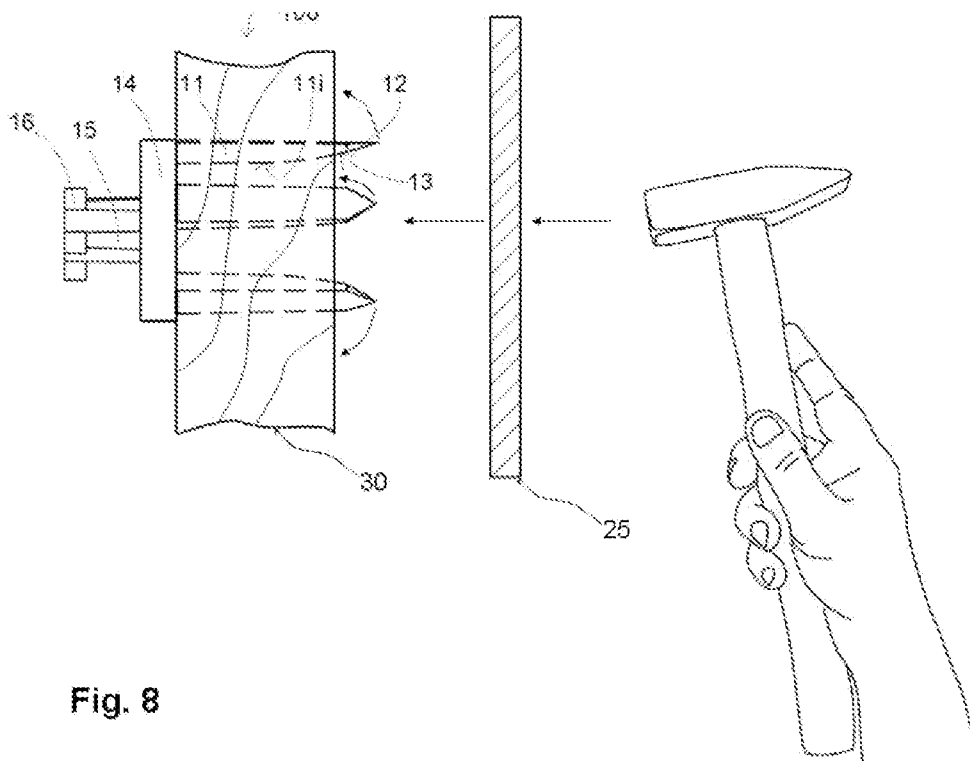

Fig. 8

Figure 9

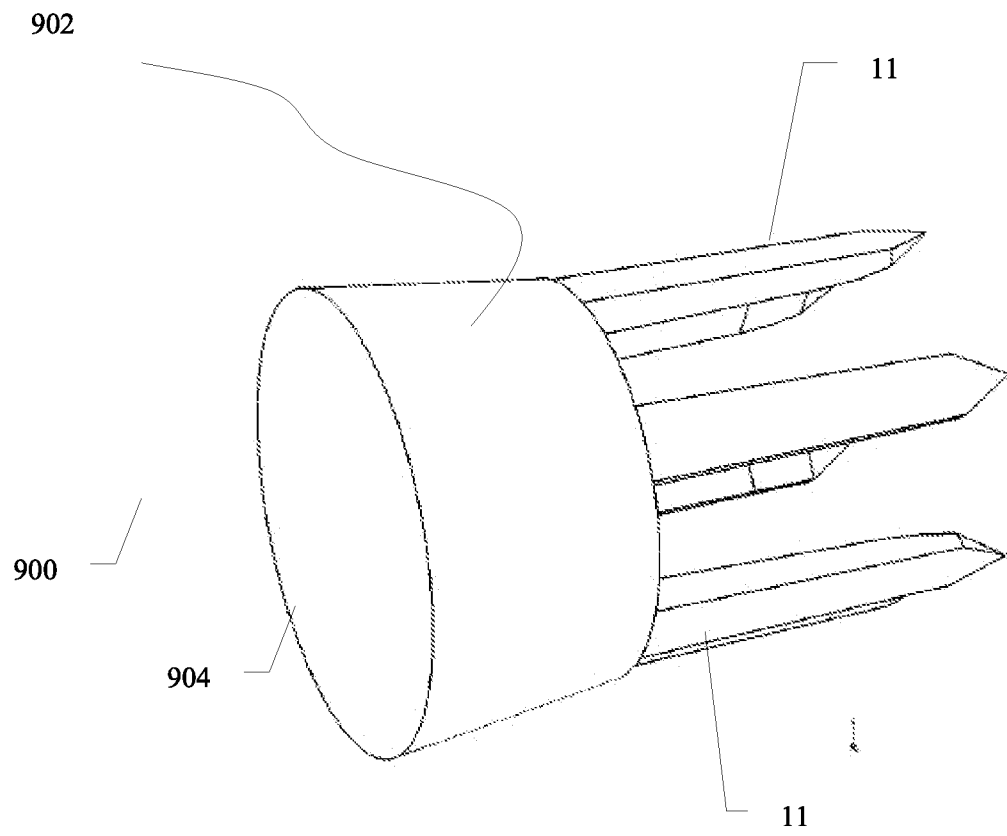

Figure 10

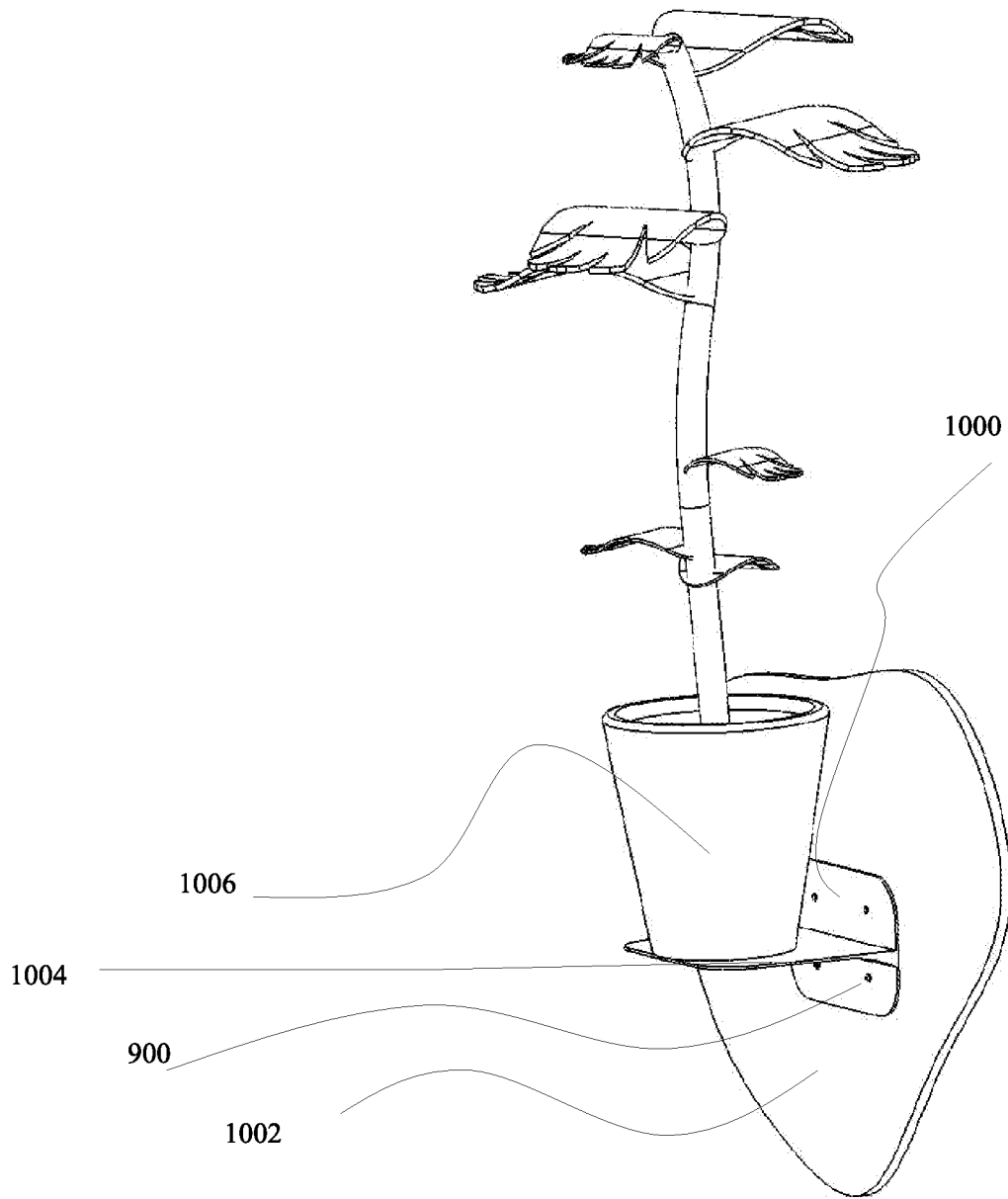
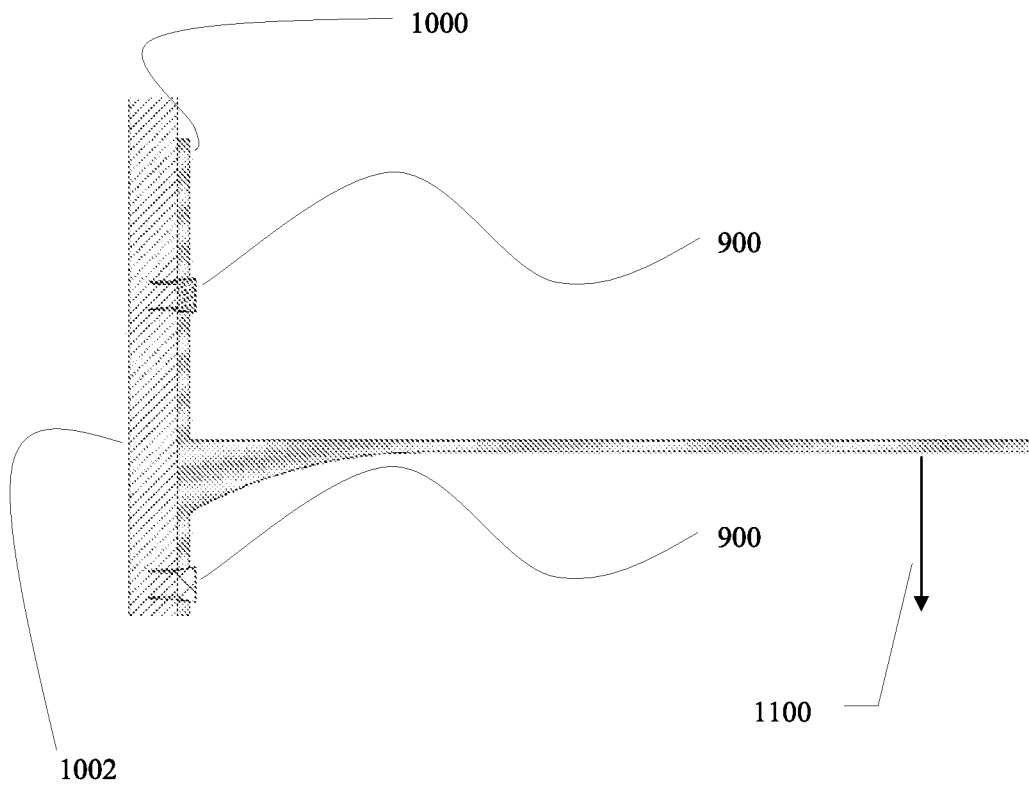

Figure 11



INTERNATIONAL SEARCH REPORT

International application No
PCT/IB2009/053654

A. CLASSIFICATION OF SUBJECT MATTER
INV. B25C1/02 B25C5/02 F16B15/00 F16B15/02

According to International Patent Classification (IPC) or to both national classification and IPC

B. FIELDS SEARCHED

Minimum documentation searched (classification system followed by classification symbols)
B25C F16B

Documentation searched other than minimum documentation to the extent that such documents are included in the fields searched

Electronic data base consulted during the international search (name of data base and, where practical, search terms used)

EPO-Internal

C. DOCUMENTS CONSIDERED TO BE RELEVANT

Category*	Citation of document, with indication, where appropriate, of the relevant passages	Relevant to claim No.
X	DE 91 14 769 U1 (TUMALSKI) 6 February 1992 (1992-02-06)	1-7, 10-13
Y	claims 4,6; figures 1-4,9	8-9,14, 18
X	EP 0 558 459 A1 (IMPORTOREX SRL [IT]) 1 September 1993 (1993-09-01) abstract; figure 2	1,5-6
Y	US 1 466 533 A (STANLISOUS KOSIENSKI) 28 August 1923 (1923-08-28) figure 4	8
Y	GB 2 268 992 A (SEAC LIMITED [GB]) 26 January 1994 (1994-01-26) abstract; figures	9,14
	-/--	

Further documents are listed in the continuation of Box C.

See patent family annex.

* Special categories of cited documents :

- "A" document defining the general state of the art which is not considered to be of particular relevance
- "E" earlier document but published on or after the international filing date
- "L" document which may throw doubts on priority claim(s) or which is cited to establish the publication date of another citation or other special reason (as specified)
- "O" document referring to an oral disclosure, use, exhibition or other means
- "P" document published prior to the international filing date but later than the priority date claimed

- "T" later document published after the international filing date or priority date and not in conflict with the application but cited to understand the principle or theory underlying the invention
- "X" document of particular relevance; the claimed invention cannot be considered novel or cannot be considered to involve an inventive step when the document is taken alone
- "Y" document of particular relevance; the claimed invention cannot be considered to involve an inventive step when the document is combined with one or more other such documents, such combination being obvious to a person skilled in the art.
- "&" document member of the same patent family

Date of the actual completion of the international search

11 January 2010

Date of mailing of the international search report

20/01/2010

Name and mailing address of the ISA/

European Patent Office, P.B. 5818 Patentlaan 2
NL - 2280 HV Rijswijk
Tel. (+31-70) 340-2040,
Fax: (+31-70) 340-3016

Authorized officer

Matzdorf, Udo

INTERNATIONAL SEARCH REPORT

International application No
PCT/IB2009/053654

C(Continuation). DOCUMENTS CONSIDERED TO BE RELEVANT		
Category*	Citation of document, with indication, where appropriate, of the relevant passages	Relevant to claim No.
X	US 3 900 143 A (GALLMAN OTICE) 19 August 1975 (1975-08-19) figures	1-4,7, 15-17,19
Y	US 2006/191233 A1 (TAMLYN JOHN T [US]) 31 August 2006 (2006-08-31) figure 1	18
X	DE 299 13 185 U1 (SCHAFFELHUBER STEFAN [DE]) 14 October 1999 (1999-10-14) page 8, line 21 - line 23; figures 6,8,9	1-4,7,15
X	DE 299 17 501 U1 (NOIZET ERWIN [DE]) 20 January 2000 (2000-01-20) figure 1	1-4, 10-11
X	US 2 020 389 A (WEST BRENNAN B) 12 November 1935 (1935-11-12) figures	1,15
A	US 3 499 359 A (YRJANAINEN JOHN J) 10 March 1970 (1970-03-10) figures 1-5	8,10-11
A	GB 2 036 226 A (ECK W VAN) 25 June 1980 (1980-06-25) figures	19
A	GB 2 399 400 A (DALTON STEPHEN GEORGE [GB]) 15 September 2004 (2004-09-15) figures	1,10-11
A	BE 673 729 A (HILTI) 1 April 1966 (1966-04-01) figure 1	15-17

INTERNATIONAL SEARCH REPORT

Information on patent family members

International application No

PCT/IB2009/053654

Patent document cited in search report	Publication date	Publication date	Patent family member(s)	Publication date
DE 9114769	U1	06-02-1992	NONE	
EP 0558459	A1	01-09-1993	IT 226291 Z2	02-06-1997
US 1466533	A	28-08-1923	NONE	
GB 2268992	A	26-01-1994	NONE	
US 3900143	A	19-08-1975	NONE	
US 2006191233	A1	31-08-2006	NONE	
DE 29913185	U1	14-10-1999	NONE	
DE 29917501	U1	20-01-2000	NONE	
US 2020389	A	12-11-1935	NONE	
US 3499359	A	10-03-1970	NONE	
GB 2036226	A	25-06-1980	NONE	
GB 2399400	A	15-09-2004	NONE	
BE 673729	A	01-04-1966	AT 263894 B	12-08-1968
			CH 459101 A	30-06-1968
			DE 1478793 A1	27-03-1969
			FR 1457166 A	13-01-1967
			GB 1091099 A	15-11-1967
			NL 6515893 A	20-06-1966
			SE 331971 B	18-01-1971
			US 3391842 A	09-07-1968