



(12) EUROPEAN PATENT APPLICATION

(43) Date of publication:
12.04.2006 Bulletin 2006/15

(51) Int Cl.:
H01R 12/08 (2006.01)

(21) Application number: 05021838.7

(22) Date of filing: 06.10.2005

(84) Designated Contracting States:
AT BE BG CH CY CZ DE DK EE ES FI FR GB GR
HU IE IS IT LI LT LU LV MC NL PL PT RO SE SI
SK TR
Designated Extension States:
AL BA HR MK YU

(72) Inventors:
• Maruishi, Masatoshi
Meguro-ku
Tokyo 152-0002 (JP)
• Aizawa, Hidenori
Meguro-ku
Tokyo 152-0002 (JP)
• Watanabe, Shinji
Meguro-ku
Tokyo 152-0002 (JP)

(30) Priority: 07.10.2004 JP 2004294956

(71) Applicant: HONDA TSUSHIN KOGYO Co., Ltd.
Tokyo 152-0002 (JP)

(74) Representative: Vossius & Partner
Siebertstrasse 4
81675 München (DE)

(54) Cable connector

(57) A cable connector (1) according to the invention includes: contacts (3) connected to core conductors (a) of coaxial cables (2), an insulating member (6) for holding the contacts, a plate-shaped grounding bar (7) put across the coaxial cables and soldered to shielding external conductors of the coaxial cables (2); and substantially flat-plate-shaped metal upper and lower shells (4 and 5) enclosing the insulating member (6) from above and be-

low to be fixed to the insulating member, the grounding bar (7) being electrically conducted to the upper shell (4) and the lower shell (5). Supporting means (4i and/or 5e) abutting against a back end surface of the grounding bar (7) is provided on at least one of flat plate parts (4e, 5a) of the upper and lower shells so as to prevent the grounding bar from being pulled backward in a core direction of the coaxial cable.

Fig. 1

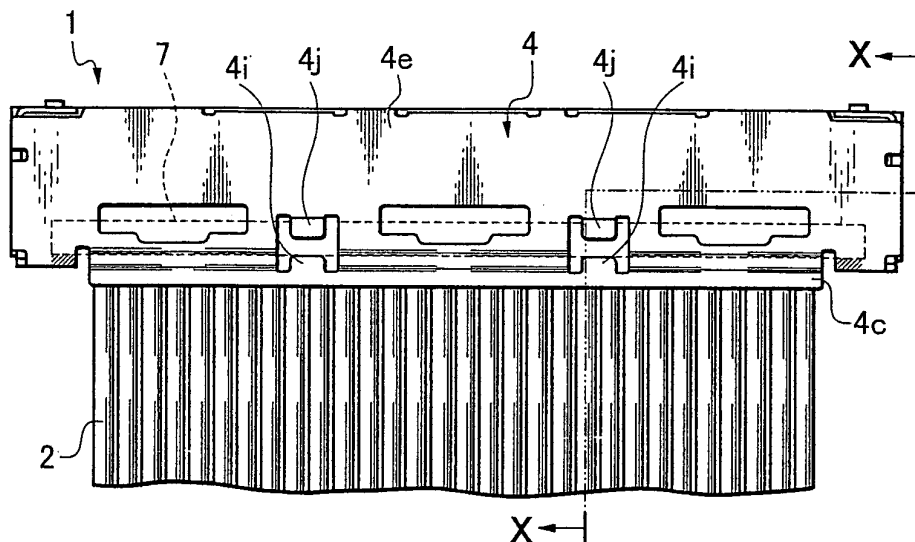

Description

[0001] The present invention relates to a cable connector to connect extra-fine coaxial cables.

[0002] Currently, in electrical equipment such as a cellular phone, for example, as shown in Figs. 7A to 7C, extra-fine coaxial cables 2 are used for connecting circuits on a printed board to electronic components so as to eliminate noise. In this case, multiple coaxial cables 2 are connected to a cable connector 11 while, as shown in Fig. 8, an insulating member 1 a made of synthetic resin is covered with metal upper and lower shells 4 and 5, and an external conductor of the coaxial cable 2 is soldered to the both shells 4 and 5 for shielding.

[0003] Then, as shown in Fig. 9, the external conductor of the coaxial cable 2 is soldered with solder 6 to a plate-shaped grounding bar 7 put across the multiple coaxial cables 2. It is known that the grounding bar 7 is soldered through press strips 4j or the like disposed on a flat plate part 4e of the metal upper shell 4 and forms a soldering part, to be electrically connected (for example, see JP-A-2002-8765).

[0004] However, in the conventional cable connector 11, the grounding bar 7 is abutted against a part of the insulating member 1 a at the right and left end parts thereof, but the center part of the grounding bar 7 is supported by the press strips 4j and 5f of the shells 4 and 5 by soldering. Therefore, when the coaxial cable 2 is pulled in the longitudinal direction thereof, the load bearing capacity of the center part of the grounding bar 7 is weak, and thus it is likely to be bent backward.

[0005] In view of such the conventional problem, an object of the invention is to provide a cable connector reinforced in its fixative force at one place so that even though the coaxial cable is pulled backward in the core direction, a grounding bar will not be moved and deformed.

[0006] Then, the cable connector according to the invention is configured to include contacts connected to core conductors of coaxial cables, an insulating member for holding the contacts, a plate-shaped grounding bar put across the coaxial cables and soldered to shielding external conductors of the coaxial cables, and substantially flat-plate-shaped metal upper and lower shells enclosing the insulating member from above and below to be fixed to the insulating member, the grounding bar being electrically conducted to the upper shell and the lower shell, wherein supporting means abutting against a back end surface of the grounding bar is provided on at least one of flat plate parts of the upper and lower shells so as to prevent the grounding bar from being pulled backward in a core direction of the coaxial cable.

[0007] The cable connector can be configured in such a manner that at least a notch part is formed at a back end part of the flat plate part having the supporting means, a press strip is formed extending and bending from an inner edge of the notch part, and the supporting means is extended from an outer edge of the notch part

opposite to the press strip. The press strip may be soldered to the grounding bar.

[0008] According to the cable connector of the invention, the grounding bar to electrically conduct the external conductor of the coaxial cable to the metal shell is put across and soldered to the external conductors of the multiple coaxial cables, and the supporting means prevents the grounding bar from being moved in the backward direction along the core direction of the coaxial cable and reinforces the fixative force at the place. Therefore, the grounding bar can be prevented from being deformed.

[0009] In addition, the supporting means can be easily formed in cutting the shells by forming in the notch part opposite to the press strips formed in the notch part of the plate part of the shell.

[0010] The invention will be more fully explained hereinafter by means of the following detailed description referring the accompanying drawings, wherein:

Fig. 1 is a plan view showing a cable connector according to an embodiment of the invention;

Fig. 2 is an enlarged cross sectional view taken along a line X-X in Fig. 1;

Figs. 3A, 3B, 3C and 3D are a front view, a bottom view, a rear view, and a right side view showing an upper shell of the cable connector, respectively;

Fig. 4 is an enlarged cross sectional view taken along a line Y-Y in Fig. 3B;

Figs. 5A, 5B and 5C are a plan view, a rear view, and a right side view showing a lower shell of the cable connector, respectively;

Fig. 5D is an enlarged cross sectional view taken along a line Z-Z in Fig. 5A;

Fig. 6 is a perspective view showing the cable connector in use;

Figs. 7A, 7B and 7C are a plan view, a front view, and a right side view showing a conventional cable connector, respectively;

Fig. 8 is an enlarged cross sectional view taken along a line A-A line in Fig. 7A; and

Fig. 9 is an enlarged cross sectional view taken along a line B-B line in Fig. 7A.

[0011] In a cable connector 1 according to the invention (hereinafter, it is simply called as "connector"), as shown in Fig. 1, core conductors of coaxial cables 2, which are extra-fine cables (outer diameter is approximately 0.3mm, for example), are connected to contacts 3 (see Fig. 8 showing a conventional example), and shielding external conductors of the coaxial cables 2 electrically conduct to a metal upper shell 4 and a metal lower shell 5 covering an insulating member from above and below for shielding it.

[0012] In assembling the connector 1, core conductors at the end part of the coaxial cables 2 are soldered to the contacts (see Fig. 8). Then, a metal-plate grounding bar 7 put across the external conductors of the multiple co-

axial cables 2 and soldered thereto is placed on the lower shell 5, soldered, and fixed thereto. After that, the upper shell 4 is mounted on the insulating member 1 a. A part of the upper shell 4 is soldered to a part of the grounding bar 7 to be integrally fixed to each other.

[0013] Here, on the flat plate parts 4e and 5a of the upper and lower shells 4 and 5, flat-plate support strips 4i and 5e are formed as supporting means, respectively, to be abutted against the back end surface of the grounding bar 7, and prevent the grounding bar 7 from being pulled backward in the core direction of the coaxial cable 2.

[0014] The support strips 4i and 5e are disposed on the back end parts of the flat plate parts 4e and 5a at positions corresponding to cable cramping parts 4c and 5g which are lowered by one step than the flat plate parts of the conventional example shown in Fig. 8 and bent so as to cramp the coaxial cable 2. More specifically, in notch parts 4k and 5h formed at the back end parts of the flat plate parts 4e and 5a, press strips 4j and 5f are formed which are bent and extended from the inner edge and are soldered to the grounding bar 7, while the support strips 4i and 5e are formed projecting from the outer edge opposite to the press strips 4j and 5f.

[0015] The support strips 4i and 5e may be formed at the same time when the notch part is formed in association with cutting process of the press strips 4j and 5f, or may be formed in a process subsequent to the cutting process.

[0016] As shown in Figs. 3A to 3D and Fig. 4, the upper shell 4 has sidewall parts 4a and 4b formed at both end parts in the right and left directions which surround the sidewall part of the insulating member 1 a turning to the lower surface. The sidewall parts 4a and 4b have the notch parts respectively and are positioned at their end surfaces 4d and 4d in the longitudinal direction thereof.

[0017] Furthermore, the right and left side wall parts of the insulating member 1 a are surrounded by a bottom plate part 4f extended from the lower end parts of the sidewall parts 4a and 4b of the upper shell 4 and a bottom plate part 4h extended from the lower end part of a back side wall part 4g.

[0018] As shown in Fig. 5A to 5C and 5D, the lower shell 5 has engagement strips 5b stood at the both sidewall parts in the right and left directions of the flat plate part 5a to be press fit into press fit holes of the insulating member 1 a, respectively. Further, the lower shell 5 has engaging-locking parts 5d extended horizontally from stand parts 5c stood at the backside of the both sidewall parts. The engaging-locking part 5d engages with a part of a shell in a board side connector 21 of the counterpart to detachably fit the cable connector 1 at the place so as not to be pulled off from the board side connector (see Fig. 6).

[0019] According to the configuration of the connector 1 of the invention, the upper and lower shells 4 and 5 fixed to the insulating member 1 a fix the grounding bar 7 at the place in the core direction of the coaxial cable 2.

Therefore, as shown in Fig. 6, when the connector 1 is fit into the board side connector 21 for use, the right and left end parts of the grounding bar 7 soldered to the external conductor of the coaxial cable 2 are positioned by the insulating member 1 a even though the coaxial cable 2 is pulled backward. Furthermore, as shown in Fig. 2, an end surface 7a in the backside of the center part in the right and left directions is abutted against the end surfaces of the support strips 4i and 5e of the upper and lower shells 4 and 5. Thus, the load bearing capacity at the center part of the grounding bar 7 is reinforced, and therefore the connector is not bent.

15 Claims

1. A cable connector comprising contacts (3) connected to core conductors (2a) of coaxial cables (2), an insulating member (6) for holding the contacts, a plate-shaped grounding bar (7) put across the coaxial cables and soldered to shielding external conductors of the coaxial cables; and substantially flat-plate-shaped metal upper and lower shells (4 and 5) enclosing the insulating member from above and below to be fixed to the insulating member, the grounding bar (7) being electrically conducted to the upper shell and the lower shell (4 and 5), **characterized in that** supporting means (4i and/or 5e) abutting against a back end surface of the grounding bar (7) is provided on at least one of flat plate parts (4e, 5a) of the upper and lower shells (4 and 5) so as to prevent the grounding bar from being pulled backward in a core direction of the coaxial cable.
2. The cable connector according to claim 1, wherein at least a notch part (4k, 5h) is formed at a back end part of the flat plate part (4e, 5a) having the supporting means (4i and/or 5e), a press strip (4j, 5f) is formed extending and bending from an inner edge of the notch part, and the supporting means (4i, 5e) is extended from an outer edge of the notch part opposite to the press strip.

Fig. 1

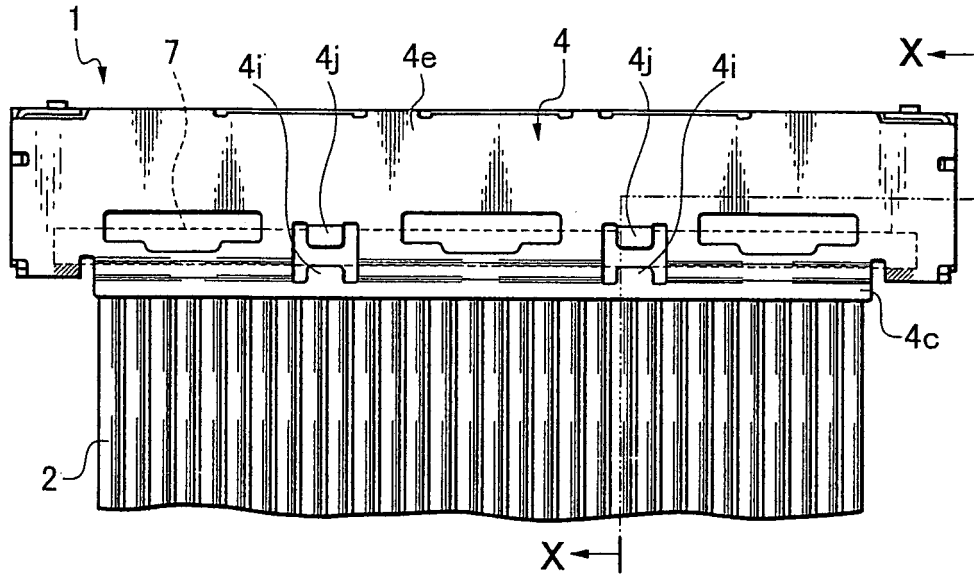

Fig. 2

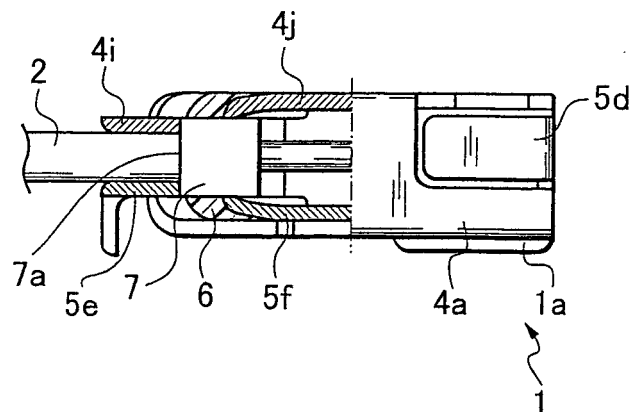

Fig. 3A

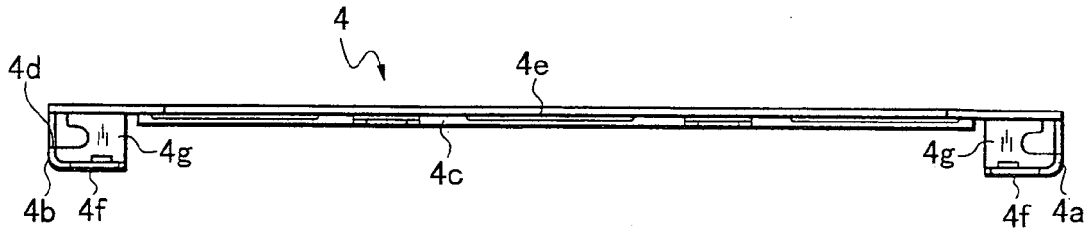

Fig. 3B

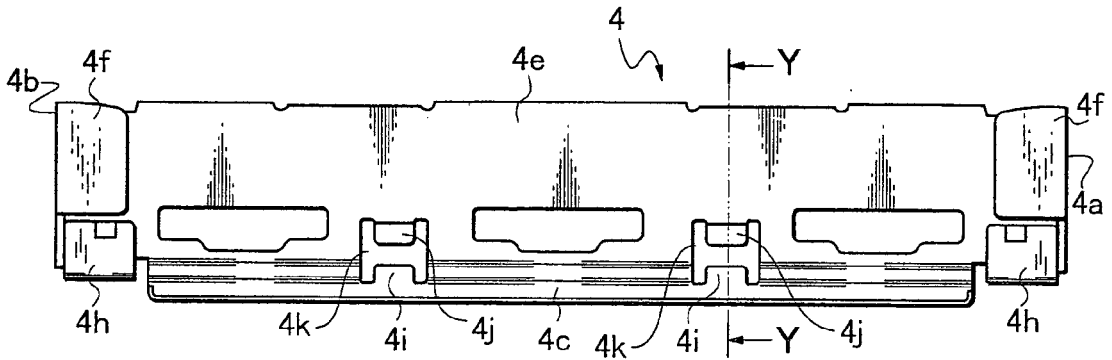

Fig. 3C

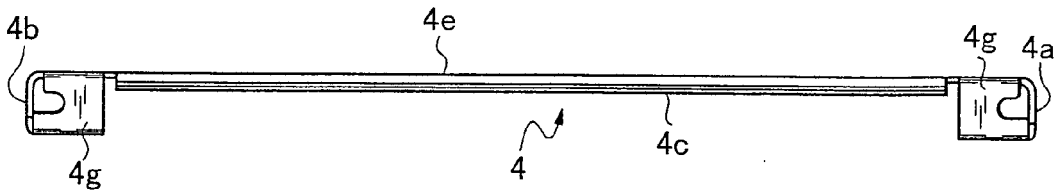

Fig. 3D

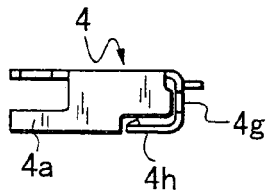

Fig. 4

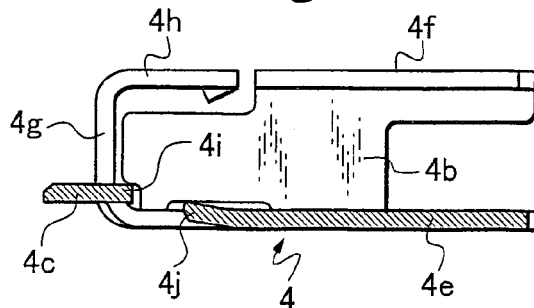

Fig. 5A

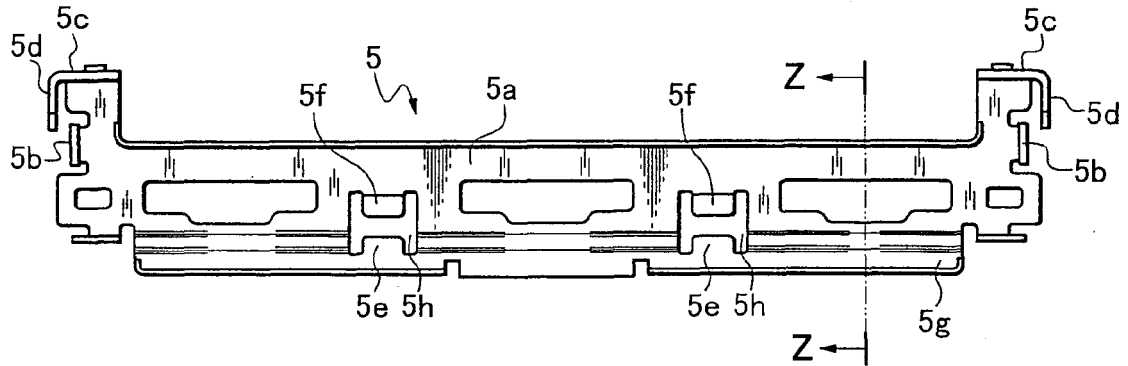

Fig. 5B

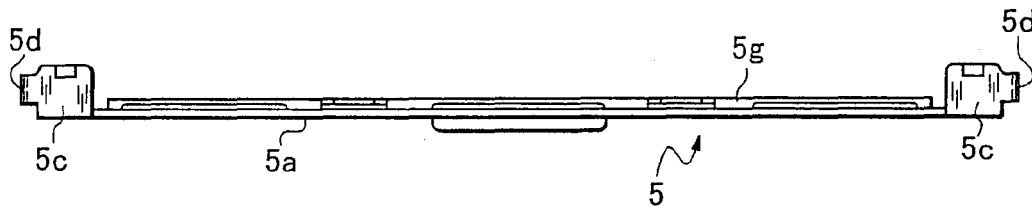

Fig. 5C

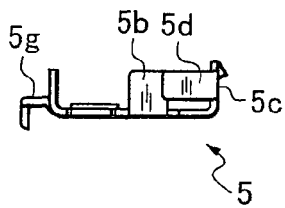

Fig. 5D

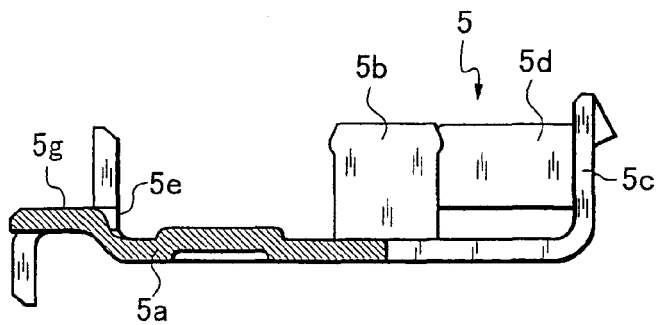

Fig. 6

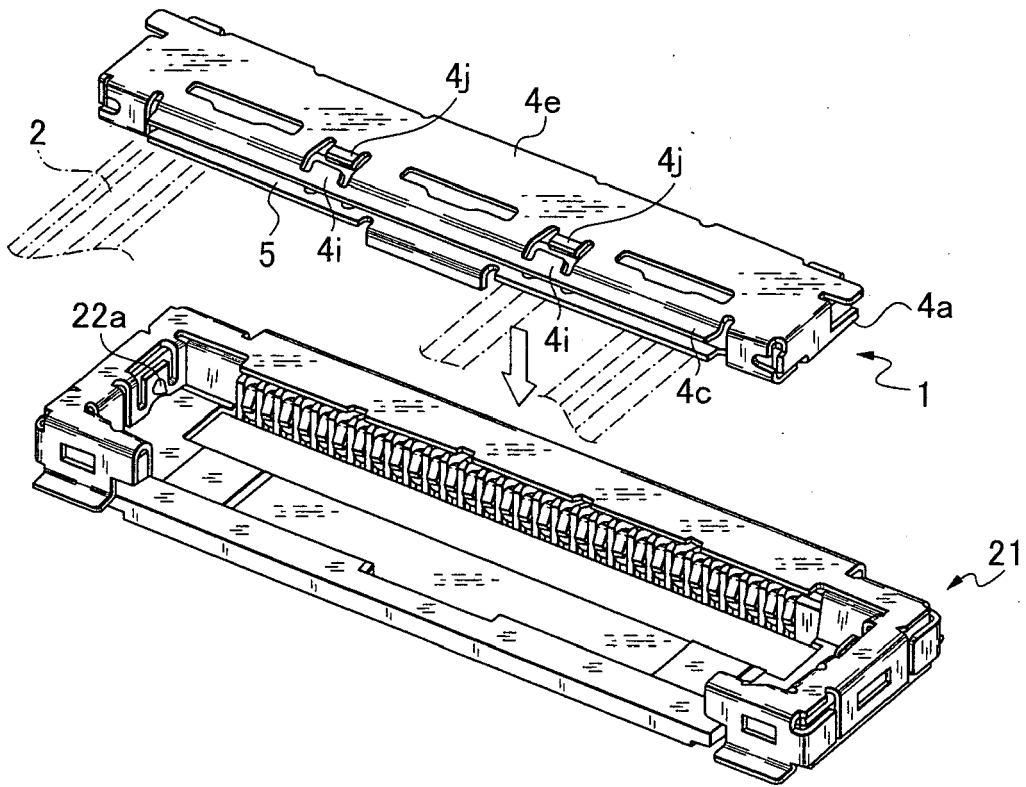

Fig. 7A

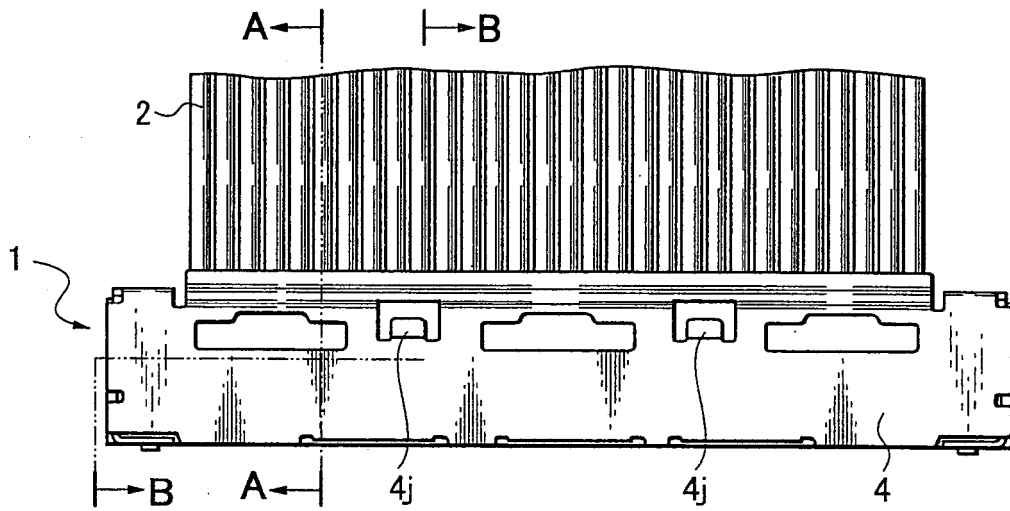

Fig. 7B

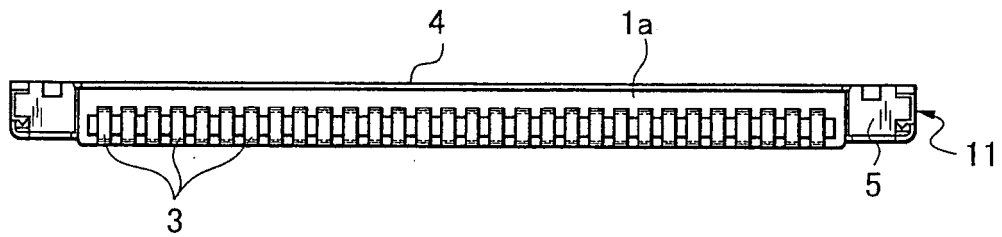

Fig. 7C

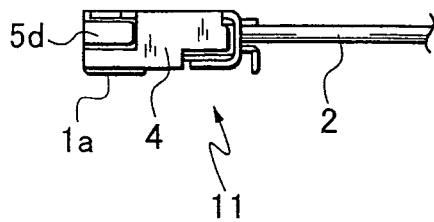

Fig. 8

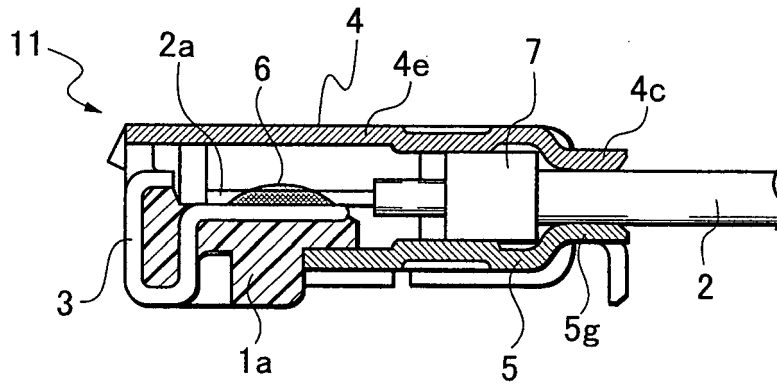

Fig. 9

