

(19) **DANMARK**



Patent- og
Varemærkestyrelsen

(10) **DK/EP 2886492 T3**

(12) **Oversættelse af
europæisk patentskrift**

-
- (51) Int.Cl.: **B 65 F 3/04 (2006.01)** **B 65 F 3/14 (2006.01)**
- (45) Oversættelsen bekendtgjort den: **2016-12-12**
- (80) Dato for Den Europæiske Patentmyndigheds bekendtgørelse om meddelelse af patentet: **2016-10-05**
- (86) Europæisk ansøgning nr.: **14198742.0**
- (86) Europæisk indleveringsdag: **2014-12-18**
- (87) Den europæiske ansøgnings publiceringsdag: **2015-06-24**
- (30) Prioritet: **2013-12-19 FI 20136294**
- (84) Designerede stater: **AL AT BE BG CH CY CZ DE DK EE ES FI FR GB GR HR HU IE IS IT LI LT LU LV MC MK MT NL NO PL PT RO RS SE SI SK SM TR**
- (73) Patenthaver: **Ab Närpes Trä & Metall - Oy Närpiön Puu ja Metall, Kristinestadsvägen 417, 64200 Närpes, Finland**
- (72) Opfinder: **Westberg, Anders, Ab Närpes Trä & Metall - Oy Närpiön Puu ja Metall, Kristinestadsvägen 417, 64200 Närpes, Finland**
- (74) Fuldmægtig i Danmark: **Plougmann Vingtoft A/S, Rued Langgaards Vej 8, 2300 København S, Danmark**
- (54) Benævnelse: **Opsamlingscontainer til en skraldevogn**
- (56) Fremdragne publikationer:
EP-A- 2 133 288
EP-A1- 1 491 464
EP-A1- 1 553 030
WO-A1-96/32346
DE-A1- 4 331 750
DE-U1- 9 407 137
FR-A1- 2 459 768
US-A- 5 123 801

DESCRIPTION

Technical field

[0001] The present invention relates to a collection container of the type presented in the preamble of claim 1.

[0002] This type of collection container is used in emptying refuse bins into a refuse collection vehicle.

Prior art

[0003] The prior art suffers from drawbacks and deficiencies in respect of collecting refuse that has been sorted according to present regulations. The sorting out of household waste according to the present regulations entails the use of several refuse bins that are often of different sizes. Problems occur easily, when the collection container is to be emptied, especially because the different chambers in the container often need to be emptied in very different places. A collection container of a refuse collection vehicle comprising several chambers is presented in the publication EP 1491464, for instance. The emptying process may be simplified by arranging the tailgates at the container to be turnable around a vertical rotation, thereby freeing each chamber for emptying the refuse collected therein. Such a solution is presented in the publication DE 43 31 750, for instance. US-A-5 123 801 discloses a collection container according to the preamble of claim 1.

Presentation of the problem

[0004] The present invention allows the problems of known solutions to be essentially avoided. Thus, the object of the invention is to provide an easy-to-use and versatile collection container. This object is achieved in accordance with the invention by giving the collection container of the invention the characterising features of claim 1. The subsequent dependent claims present appropriate further developments and variations of the invention which further improve its operation.

[0005] In the following description, the terms "up", "down", "above", "below" and the like refer to directions in relation to the collection container or its structural details as shown in the attached figures.

[0006] With the collection container described in the present invention, significant advantages are achieved over the prior art. The invention helps simplify emptying the chambers of the collection container of refuse by opening the tailgates of the collection container in any order.

[0007] Further advantages and details of the invention become apparent from the description below.

Brief description of the figures

[0008] In the following, the invention will be described in greater detail with reference to the drawing, in which

Figure 1 is a schematic view of a collection container of a refuse collection vehicle with a bin lift in the back part of the collection container as seen diagonally from the back with all gripping units in a lower open position, ready to receive a refuse bin,

Figure 2 shows a collection container according to Figure 1 with two outer tailgates open and ready for emptying,

Figure 3 shows a collection container according to Figure 1 with a middle tailgate open and ready for emptying,

Figure 4 shows a bin lift according to Figure 1 with all its gripping units in a lower open position,

Figure 5 shows a gripping unit in detail,

Figure 6 is another detail view of the gripping unit,

Figure 7 shows a bin lift according to Figure 1 with two of its gripping units in an upper closed position,

Figure 8 shows a cross-sectional view of a bin lift along plane A-A of Figure 7,

Figure 9 shows a bin lift and a refuse bin arranged thereto,

Figure 10 shows a cross-sectional view of a bin lift along plane B-B of Figure 9,

Figure 11 shows a bin lift and two refuse bins positioned thereto,

Figure 12 shows the refuse bins of Figure 11 locked by a gripping unit to the bin lift.

Preferred embodiment

[0009] The above figures do not show the collection container in scale but only serve to illustrate the structural solutions and operation of the preferred embodiment. Herein, the respective structural parts shown in the figures and denoted with reference numerals correspond to the structural solutions presented in the description below and which are hereby given their reference numbers.

[0010] The figures show a collection container 1 and its structural element in a refuse collection vehicle, which generally comprises a chassis and driver's cab that are not shown herein. The figures show a collection container or a part thereof, in which collected refuse is transported from a collection site to a processing plant or disposal site. The collection container is in this case divided into three side-by-side chambers 2, 3, and 4 with vertical partition walls 5 and 6 that extend in the longitudinal direction of the refuse collection vehicle. The number and width of the chambers may naturally vary depending on the type of refuse to be transported in the vehicle. The number of chambers is at least three. The tail end of the collection container is open to provide loading and emptying openings for each chamber.

[0011] For loading refuse into the collection container 1, the refuse collection vehicle is at the back of the container provided with tailgates 7, 8, and 9, often called compactors, the number of which corresponds to the number of chambers in the collection container. The present embodiment has three chambers 2, 3, and 4 and three tailgates. Each of the tailgates has a hopper 10, 11, and 12 in front of the chamber in accordance with Figure 4, for instance, for receiving the collected refuse. Each tailgate further has a packer blade 13 known per se and movable by means of a hydraulic device, which moves along the bottom of the hopper and transports refuse to the loading and emptying opening. The packer blade can be seen partially in Figures 8 and 10. Each tailgate is arranged to be turnable around a rotation axis on the edge of the loading and emptying opening. The two outer tailgates 2 and 3 in the present embodiment are turnable around a substantially vertical axis 14 and 15, while the middle one is turnable around a horizontal axis 16.

[0012] Both the collection container and the tailgates have a conventional structure, which is why they are not described in more detail herein.

[0013] So as to load the collection container 1 with refuse, the refuse collection vehicle comprises a bin lift 17, with which refuse bins 18 can be tipped over the hopper 10, 11, and 12 of the tailgate 7, 8, and 9. For this purpose, the bin lift has an essentially U-shaped carrier arm 19 that is preferably pivoted to the collection container of the refuse collection vehicle. See Figures 2 and 8, for example. The carrier arm comprises at least two substantially parallel levers 20 that extend from articulated fasteners 21 in the collection container backward from the back of the collection container. A crossbar 22 is pivoted to the levers and will in the operating position of the refuse collection vehicle be in a substantially vertical position. The crossbar comprises a frame 23 equipped with at least two gripping units 24 that are movable along the frame and arranged to be independently manoeuvred. With these gripping units, the carrier arm is arranged to grip the lifting mountings of a refuse bin 18 brought close to the refuse collection vehicle for lifting and/or swinging the refuse bin in relation to the collection container substantially vertically and for emptying it in the appropriate hopper. The carrier arm is manoeuvred with at least one handling device that is a pneumatic or hydraulic cylinder 25, for example.

[0014] So as to permit the opening of one or several middle tailgates 9, the carrier arm 19 is arranged to be rotatable around a horizontal axis above said tailgate. The collection container according to Figure 3 has at least two parallel swing arms 26 that are at their upper ends fastened to pivots 27 above the middle tailgates and at their lower ends arranged to carry the bin lift. When a middle tailgate is to be opened, the swing arms are rotated to move the bin lift to a position away from the transport track for refuse that is emptied from the chamber. So as to enable the swinging movement of the swing arms, the collection container has a passage between adjacent tailgates. When the bin lift has reached its end position, the middle tailgates can be lifted to enable the emptying of the chambers at the back.

[0015] If the collection container 1 has three tailgates 7, 8, and 9, said swing arms 26 can preferably form part of the middle tailgate and its frame. This way, the tailgate 9 and bin lift 17 will have a common rotation axis and rotate simultaneously to a position above the collection container to enable the emptying of the chamber 4 behind the tailgate.

[0016] The carrier arm 19 of the above-mentioned bin lift 17 has readers 28, see Figures 6 and 8, which sense the position of a refuse bin 18 brought to the bin lift. A reader according to the figures comprises a mechanical latch that works together with an electric controller, but the reader can also be an optical or electronic device. As soon as the refuse bin has acted on the reader, the appropriate gripping unit is moved so as to arrange, in cooperation with a stopper 29 in the crossbar 22, the refuse bin to a substantially stationary position on the carrier arm by pressing the lifting mountings of the refuse bin against the stopper of the crossbar.

[0017] The gripping unit 24 is preferably arranged to the frame 23 of the crossbar 22 with guides 30, for instance, in accordance with Figures 5 and 6. These guides control the movement of the gripping units in a substantially vertical direction. The gripping units are manoeuvred by the handling device 31 that is shown partially in Figures 6 and 7. The handling device comprises pneumatic or hydraulic cylinders, for example, or electric spindle motors that work together with said readers 28 that start the handling device with a control signal. The gripping units preferably have a cam-type structure 32 on their edges facing the stopper 29 of the crossbar 22. This cam-type form facilitates cooperation with refuse bins 18 having different widths.

[0018] Because the gripping units 24 cooperate with said readers 28, a limited number of units are always moved simultaneously to grip a refuse bin 18. Thanks to this characteristic, it is possible to position one or more refuse bins beside each other in the bin lift 17. Once the first refuse bin has been arranged to the crossbar 22, the next refuse bin can be moved against the crossbar, after which the readers control the next gripping units into operation. This way, it is possible to position a refuse bin simultaneously for each chamber in the bin lift and considerably speed up the handling of refuse bins during refuse collection. It is also possible to position refuse bins having different widths and forms beside each other, because the readers activate separately the required number of gripping units for each refuse bin.

[0019] It is even possible to equip the reader 28 with a counter that enables the registration of the number of refuse bins emptied in every hopper during the day. Thus, the number of refuse bins emptied in each chamber can be calculated during the day.

[0020] In a solution of the present embodiment, the collection container 1 has three chambers 2, 3, and 4 with corresponding three tailgates 7, 8, and 9 and hoppers 10, 11, and 12. The carrier arm 19 pivoted to the collection container and its crossbar 22 have three disc-like and rectangular gripping units 24 arranged to the frame 23 of the crossbar through guides 30 arranged in pairs at what is to form the vertical edges of the gripping units. The gripping unit has on its upper edge a cam-type structure 32, while its lower edge has a shock-absorbing arrangement 33.

[0021] Each gripping unit 24 is manoeuvred by the handling device 31 to a movement that coincides essentially with the surface of the crossbar's frame 23. The movement extends from the stopper 29 on the crossbar to a distance of 100 to 150 mm, for example, from it so as to provide enough space to move the lifting mountings of the refuse bin 18 against the frame of the crossbar. Each gripping unit is preferably equipped with said readers 28 so as to react when a refuse bin is moved to its surroundings. The readers that are affected by the positioning of the refuse bin against the crossbar make the corresponding gripping unit move, whereby the refuse bin is pressed against the stopper of the crossbar. The process is illustrated in Figures 9 to 12, for example. This process can then be repeated as long as there is space for a refuse bin in the bin lift, or as long as the contents of the refuse bin correspond to the refuse that is collected in the still free chamber.

[0022] The above description and the related figures are only intended to illustrate the present solution for the construction of a collection container. Thus, the solution is not confined merely to the embodiments described above but a plurality of variations or alternative embodiments is feasible within the idea described in the attached claims.

REFERENCES CITED IN THE DESCRIPTION

This list of references cited by the applicant is for the reader's convenience only. It does not form part of the European patent document. Even though great care has been taken in compiling the references, errors or omissions cannot be excluded and the EPO disclaims all liability in this regard.

Patent documents cited in the description

- EP1491464A [0003]
- DE4331750 [0003]
- US5123801A [0003]

Opsamlingscontainer til en skraldevogn

Patentkrav

1. En opsamlingscontainer (1) til en skraldevogn, opsamlingscontaineren omfattende
5 mindst tre kamre (2, 3, 4) med lige så mange tilsvarende bagklapper (7,8,9) foran disse til opsamling og sammenpresning af affald, hvor bagklapperne er anbragt til at være drejelige omkring en rotationsakse (14, 15, 16) på en kant af en læsnings- og tømningåbning tilvejebragt for hvert kammer ved bagenden af opsamlingscontaineren for at frigøre hvert kammer til at tømme
10 affaldet opsamlet deri, **kendetegnet ved at** opsamlingscontaineren (1) yderligere omfatter en spandelift (17), med hvilken skraldespande (18) er indrettet til at blive tippet over en tragt (10, 11, 12) af en bagklap, og **ved at** to ydre bagklapper (7, 8) er drejelige omkring en i det væsentlige vertikal akse (14, 15), mens midterste bagklapper (9) anbragt mellem de to ydre bagklapper er
15 drejelige omkring en horisontal akse (16).

2. En opsamlingscontainer (1) ifølge krav 1, **kendetegnet ved at** de midterste bagklapper (9) anbragt mellem de to ydre bagklapper (7, 8) er drejelige omkring en fælles horisontal akse (16).
20

3. En opsamlingscontainer (1) ifølge krav 1 eller 2, **kendetegnet ved at** spandeliften (17) har en i alt væsentligt U-formet bæream (19) drejeligt anbragt i forhold til opsamlingscontaineren (1), hvorved bæreamen omfatter mindst to i det væsentlige parallelle løftestænger (20) og en tværstiver (22) anbragt drejeligt
25 til de mindst to løftestænger (20) for at indgribe med en eller flere skraldespande.

4. En opsamlingscontainer (1) ifølge krav 3, **kendetegnet ved at** bæreamen (19) på spandeliften (17) er anbragt til at være drejelig omkring den fælles horisontale akse (16) til en position over opsamlingscontaineren.
30

5. En opsamlingscontainer (1) ifølge krav 3 eller 4, **kendetegnet ved at** opsamlingscontaineren (1) har mindst to parallelle svingarme (26) som ved deres øvre ender er fastgjort til drejetapper (27) over de midterste bagklapper (9) anbragt mellem de to ydre bagklapper (7, 8) og ved deres nedre ender er

anordnet til at bære spandeliftten (17).

6. En opsamlingscontainer (1) ifølge krav 5, **kendetegnet ved at** opsamlingscontaineren (1) har tre kamre (2, 3, 4) med tre tilsvarende af 5 bagklapperne (7, 8, 9) og svingarmene (26) danner en del af den midterste bagklap (9) og en ramme deraf.

DRAWINGS

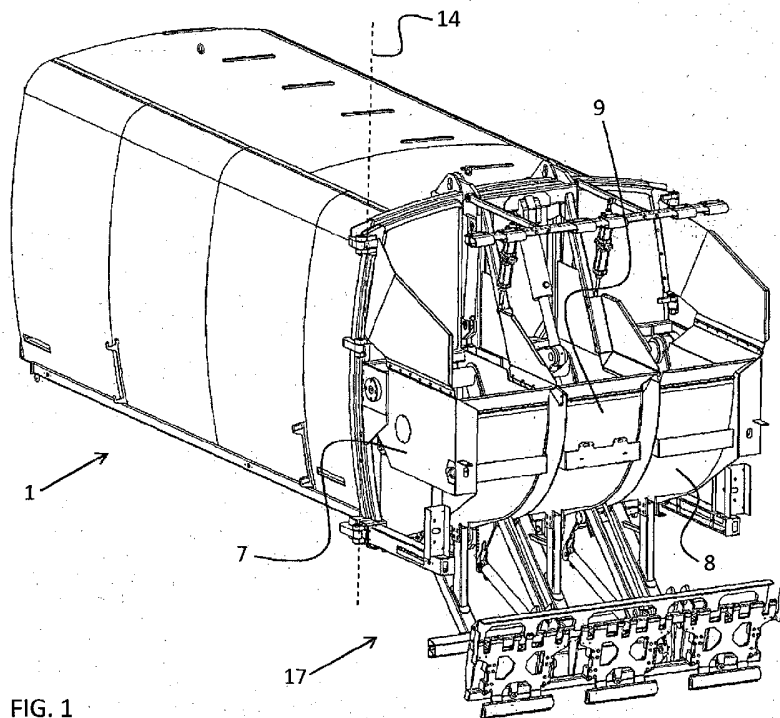
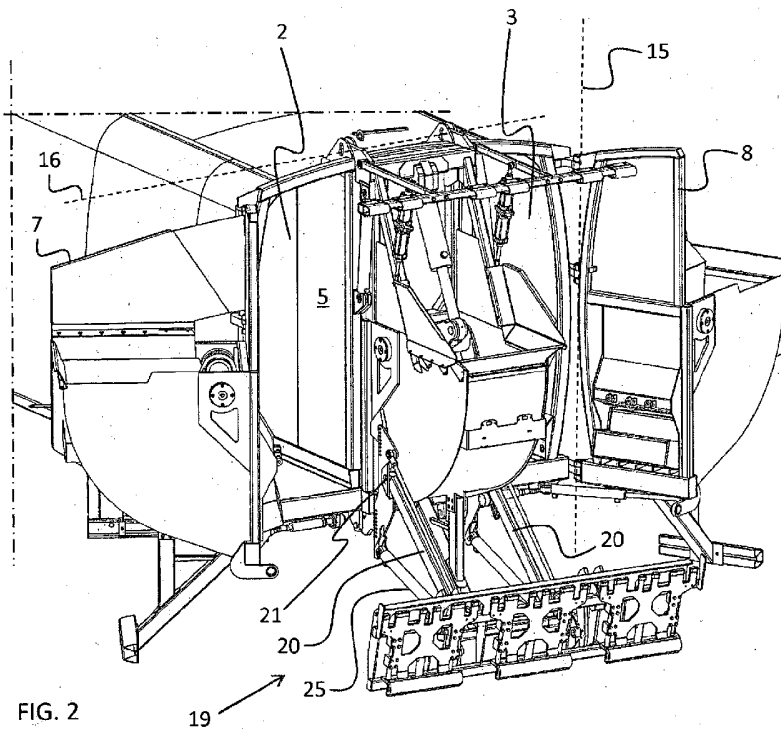

FIG. 1



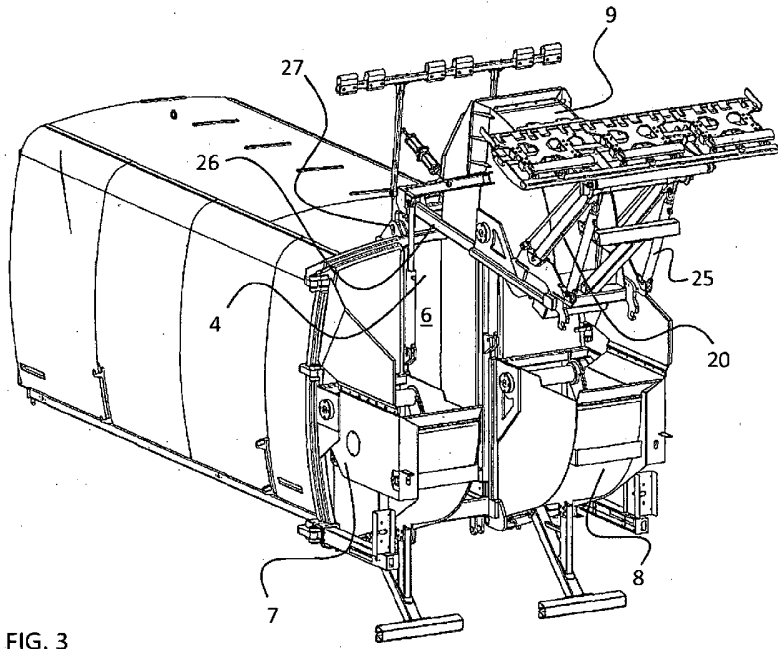

FIG. 3

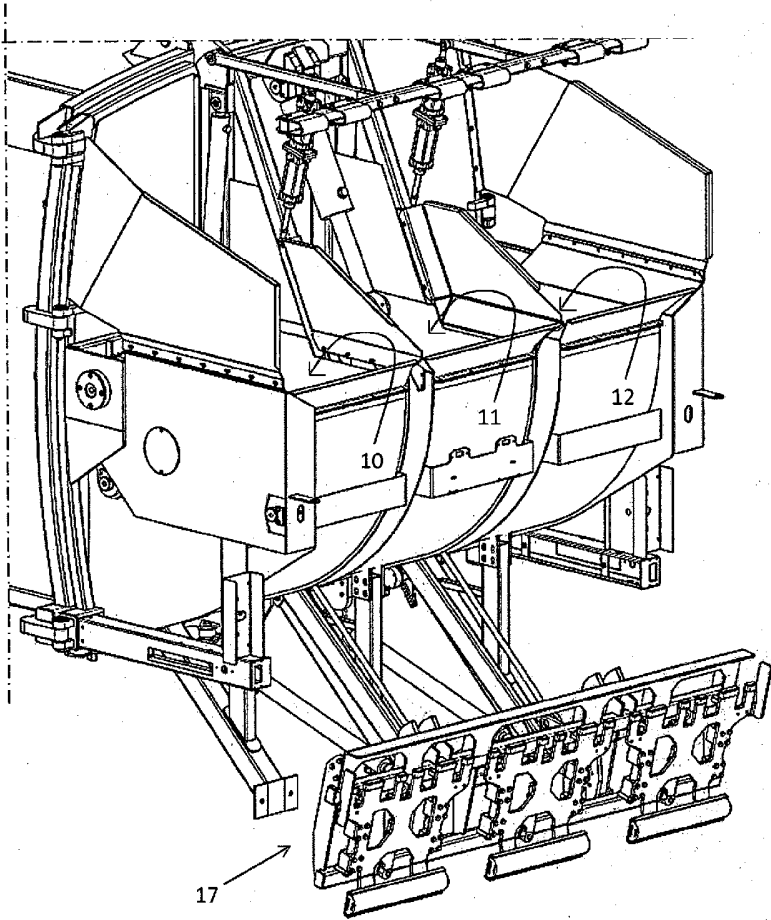
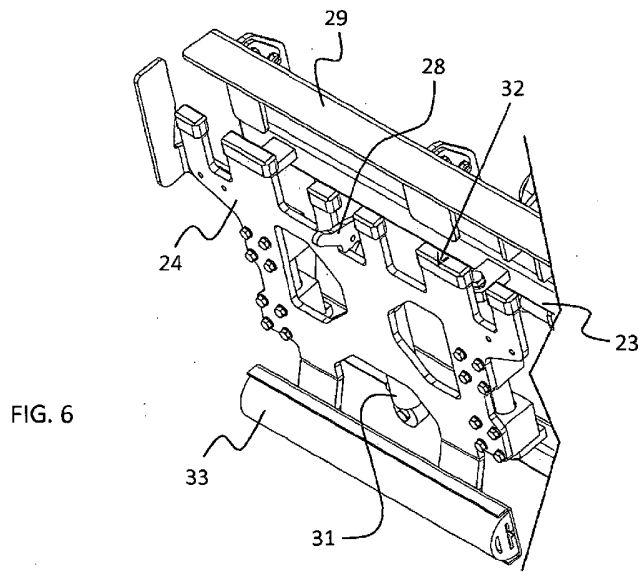
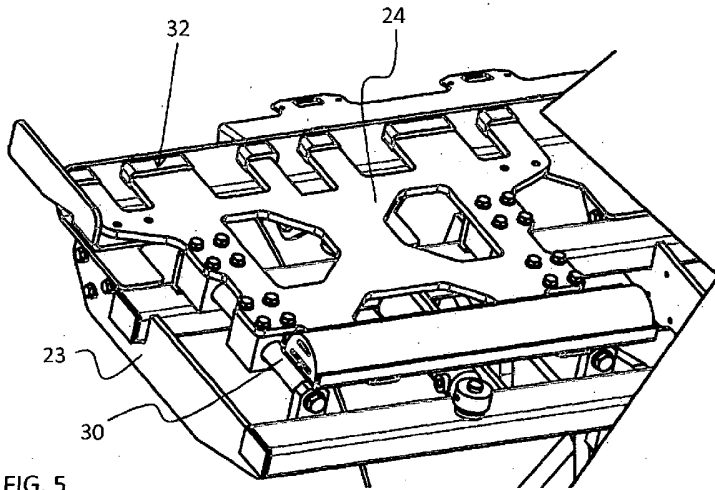

FIG. 4



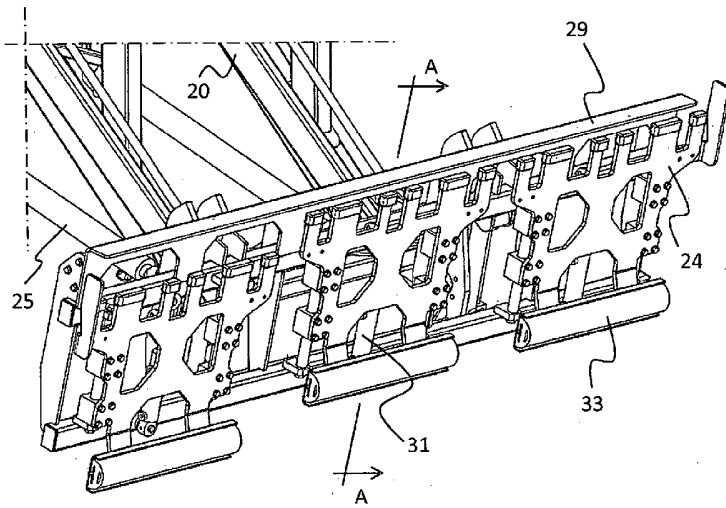

FIG. 7

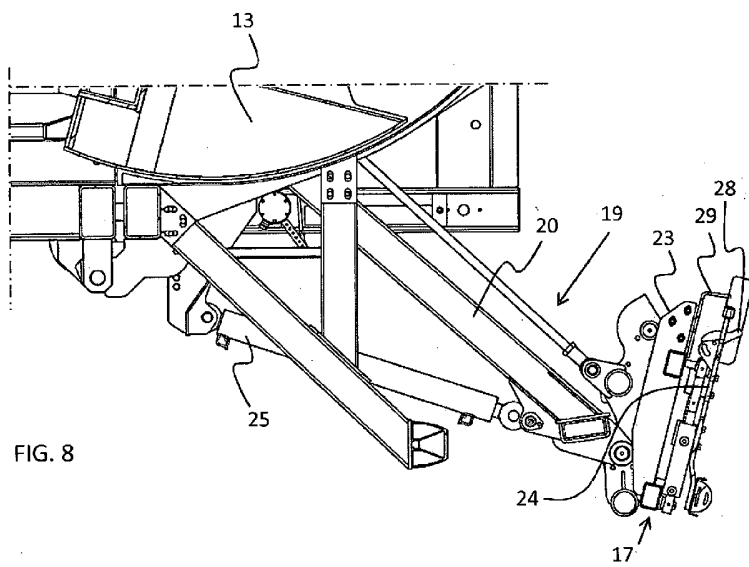
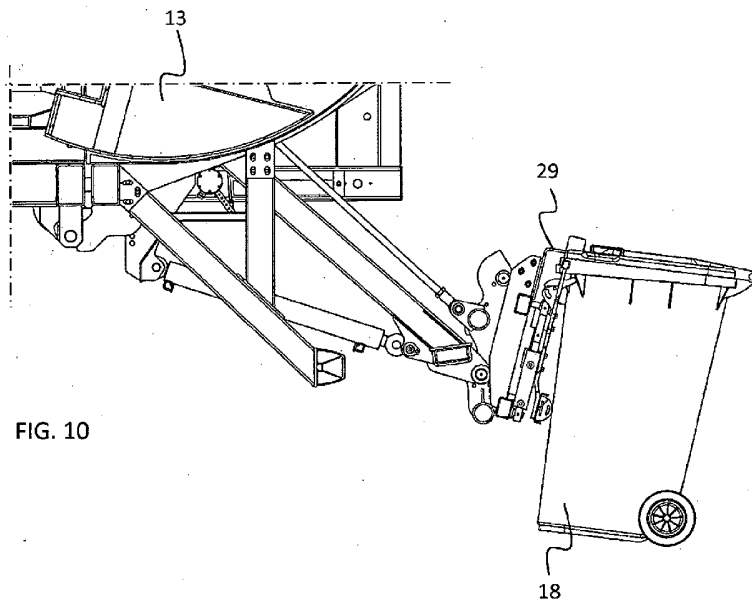
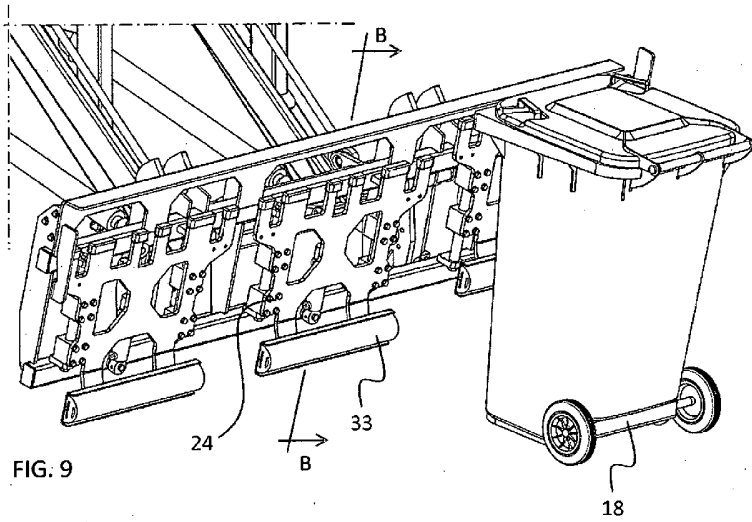

FIG. 8



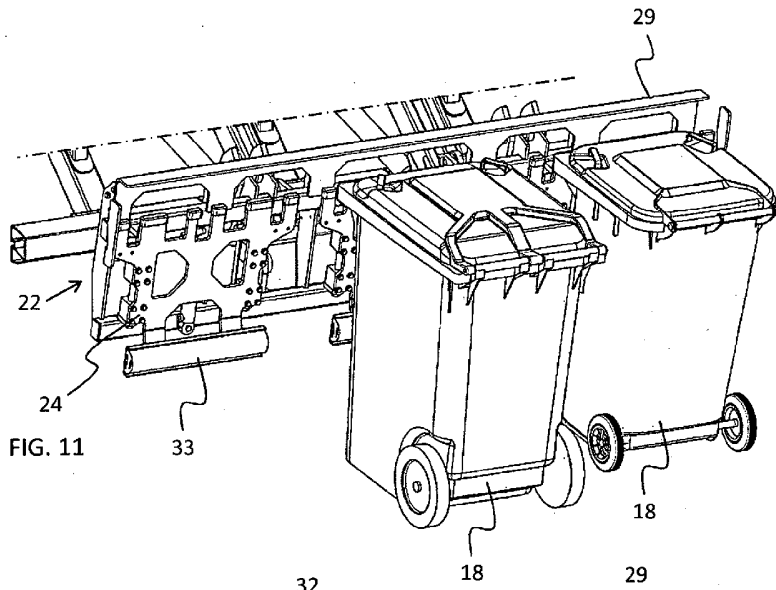

FIG. 11

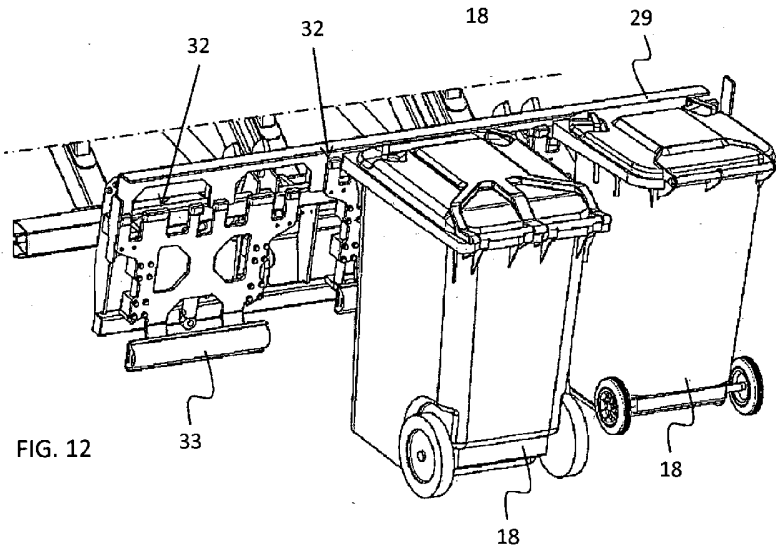

FIG. 12