



- (51) **International Patent Classification:** Not classified
- (21) **International Application Number:** PCT/EP2012/074088
- (22) **International Filing Date:** 30 November 2012 (30.11.2012)
- (25) **Filing Language:** English
- (26) **Publication Language:** English
- (30) **Priority Data:** A 2011/12957 26 December 2011 (26.12.2011) TR
- (71) **Applicant (for all designated States except US):** ARCELIK ANONIM SIRKETI [TR/TR]; E5 Ankara Asfalti Uzeri, Tuzla, 34950 Istanbul (TR).
- (72) **Inventors; and**
- (71) **Applicants (for US only):** CELIK, Kadir Ridvan [TR/TR]; E5 Ankara Asfalti Uzeri, Tuzla, 34950 Istanbul (TR). DEMIREL, Osman Cihan [TR/TR]; E5 Ankara Asfalti Uzeri, Tuzla, 34950 Istanbul (TR).
- (81) **Designated States (unless otherwise indicated, for every kind of national protection available):** AE, AG, AL, AM, AO, AT, AU, AZ, BA, BB, BG, BH, BN, BR, BW, BY,

BZ, CA, CH, CL, CN, CO, CR, CU, CZ, DE, DK, DM, DO, DZ, EC, EE, EG, ES, FI, GB, GD, GE, GH, GM, GT, HN, HR, HU, ID, IL, IN, IS, JP, KE, KG, KM, KN, KP, KR, KZ, LA, LC, LK, LR, LS, LT, LU, LY, MA, MD, ME, MG, MK, MN, MW, MX, MY, MZ, NA, NG, NI, NO, NZ, OM, PA, PE, PG, PH, PL, PT, QA, RO, RS, RU, RW, SC, SD, SE, SG, SK, SL, SM, ST, SV, SY, TH, TJ, TM, TN, TR, TT, TZ, UA, UG, US, UZ, VC, VN, ZA, ZM, ZW.

- (84) **Designated States (unless otherwise indicated, for every kind of regional protection available):** ARIPO (BW, GH, GM, KE, LR, LS, MW, MZ, NA, RW, SD, SL, SZ, TZ, UG, ZM, ZW), Eurasian (AM, AZ, BY, KG, KZ, RU, TJ, TM), European (AL, AT, BE, BG, CH, CY, CZ, DE, DK, EE, ES, FI, FR, GB, GR, HR, HU, IE, IS, IT, LT, LU, LV, MC, MK, MT, NL, NO, PL, PT, RO, RS, SE, SI, SK, SM, TR), OAPI (BF, BJ, CF, CG, CI, CM, GA, GN, GQ, GW, ML, MR, NE, SN, TD, TG).

Published:

- without international search report and to be republished upon receipt of that report (Rule 48.2(g))

- (54) **Title:** A COOLING DEVICE COMPRISING A LOCKING MECHANISM

Figure 1

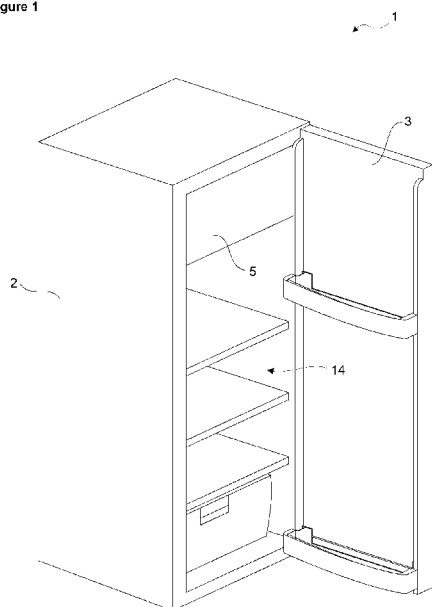

- (57) **Abstract:** The present invention relates to a cooling device (1) comprising a body (2), at least one door (3) providing access into the body (2), at least one compartment (4) disposed inside the body (2) wherein foodstuffs are placed for cooling, a cover (5) providing access into the compartment (4) and a locking mechanism (6) that provides the cover (5) to remain in the locked position by locking, and wherein the cover (5) thereof is used effectively by means of the locking mechanism (6).

Description

A COOLING DEVICE COMPRISING A LOCKING MECHANISM

- [0001] The present invention relates to a cooling device comprising a cover providing access into at least one of the compartments thereof and a locking mechanism providing the cover to remain closed.
- [0002] In cooling devices, particularly in refrigerators, the fresh food compartment and the freezing compartment are provided, that are at different temperatures from each other. In single door refrigerators, the fresh food compartment and the freezing compartment open into the same volume. In this situation, at least one of the compartments is closed by a heat insulated cover so that the airs of the two compartments do not mix with each other. Since the fresh food compartment is used more frequently by users, utilization of the cover in the fresh food compartment is not preferred. The covers, which are generally used for accessing the freezing compartment, are mounted to the body rotatably from one side. Some covers are hinged in prestressed manner to eliminate the probability of being forgotten open or being damaged when the door is closed and when released in the open position, change to the closed position automatically. Difficulty of utilization arises since the covers of this configuration should be held by the user continuously during use of the freezing compartment. In embodiments wherein locking mechanisms are used, the cover cannot be opened easily thereby causing consumer dissatisfaction.
- [0003] In the state of the art German Patent Application No. DE3613439, a single door refrigerator comprising two compartments at different temperatures is described. The fresh food compartment and the freezing compartment are separated by an intermediate shelf and the freezing compartment opening is closed by a cover that can be opened from the top downwards so as to be rotatable around the axis parallel to the ground. In this embodiment, the cover is mounted on the intermediate shelf and closes by itself when released from the open position by means of the spring fitted on the pin providing rotation.
- [0004] In the state of the art German Utility Model No. DE8530507, a compartment cover comprising a locking mechanism is described. In this

embodiment, a protrusion is disposed at the side of the cover and a housing on the side wall of the body so as to clasp the protrusion. When the door is closed, the protrusion enters into the housing and locks the cover. When the cover is pulled, the protrusion is released from the housing and provides the cover to be opened.

- [0005] In the state of the art International Patent Application No. WO03018943, a compartment cover having a locking mechanism is described. In this embodiment, an S shaped latch that can function as a spring is placed into a housing arranged on the side of the cover. While the cover is closed, the latch stretches and crosses over the protrusion disposed on the body and provides the cover to be locked.
- [0006] The aim of the present invention is the realization of a cooling device comprising a cover that can be opened/closed easily and which provides an effective leak-proofing when in the closed position.
- [0007] The cooling device realized in order to attain this aim of the present invention, explicated in the first claim and the respective claims thereof, comprises a cover providing access into a compartment disposed inside the body and a locking mechanism that provides the cover to be locked.
- [0008] The locking mechanism comprises a guide disposed on one of the compartment walls so as to correspond to the side of the cover and a latch mounted rotatably on one of the side walls of the cover and which provides the door to be closed by being seated behind the guide when the cover is closed. The guide is preferably triangular shaped, with the base facing the base of the compartment and the peak point facing the compartment ceiling. The latch is of a structure that suddenly widens just after the rotation point. While the cover is closed, the wide portion of the latch moves over the surface of the guide facing the outside of the compartment and a while later is seated on the surface of the guide facing the inside of the compartment by crossing over the peak point. While the latch is in this position, the cover remains closed as long as there is no intervention from the outside.
- [0009] In an embodiment of the present invention, the corners of the guide and the latch contacting each other are rounded. Thus, the latch moves more

easily over the guide and the cover is opened/closed more easily.

- [0010] In a version of this embodiment, the guide is shaped triangularly with rounded corners. The base of the guide faces the compartment base and the peak point faces the ceiling of the compartment. The latch has a concave portion that is seated on the peak point of the guide when the cover is closed and a head portion that bears against the rear side of the guide from the end of the concave portion when seated on the peak point of the guide. Thus, the cover can be easily closed and opened.
- [0011] In a version of this embodiment, the locking mechanism comprises a biasing means that provides the latch to resume the initial position after the rotational movement thereof. The biasing means, which is preferably a spring, is connected to the cover from one end and to the latch from the other end.
- [0012] In an embodiment of the present invention, a support member is used in order to mount the components of the locking mechanism to the cover more easily. The support member is shaped like a rectangular prism with one surface removed. In this embodiment, the latch and the biasing means are grouped on the support member and mounted to the housing disposed on the cover. The housing is disposed on the side wall of the cover. The housing is configured to be seated into the support member almost without any gaps.
- [0013] In a version of this embodiment, the support member is detachably mounted into the housing. Thus, when any one component of the locking mechanism is damaged, dislodging only the support member instead of the whole cover can be sufficient.
- [0014] In a version of this embodiment, at least one recess is arranged on the housing and at least one detent means on the outer surface of the support member. The detent means is like a triangular prism that extends outwards from the outer surface of the support member. The recess is disposed on the housing so as to be aligned with the detent means when the support member is mounted to the housing. The base cross-section of the detent means is almost the same size as the cross-section of the recess. While the support member is mounted to the housing, the detent

means is placed into the recess and is not dislodged due to the triangular shape of the detent means.

[0015] In an embodiment of the present invention, a protrusion is disposed on the rear side of the guide providing it to be mounted to the body. The protrusion is produced from resilient material and is placed into a housing inside the body. Thus, the guide is provided to be mounted to the body without any connection members.

[0016] In an embodiment of the present invention, the cover is mounted on the body rotatably from one side. The locking mechanism is on the side which is opposite to the side where the rotational axis of the cover is located.

[0017] In a version of this embodiment, the cover and the door open in the same direction. Thus, even if the door is closed by forgetting the cover in open position, the door does not damage the cover and provides the closing of the cover by rotating it with its own weight.

[0018] In an embodiment of the present invention, the cooling device is a single door refrigerator comprising the fresh food compartment and the freezing compartment.

[0019] By means of the present invention, the compartment cover is provided to be opened and closed more easily. Furthermore, the cover presses on the body more tightly by means of the locking mechanism and thus the insulation of the air inside the body is improved. Production and maintenance costs are decreased due to the modular structure of the locking mechanism.

[0020] The cooling device realized in order to attain the aim of the present invention is illustrated in the attached figures, where:

[0021] Figure 1 - is the perspective view of a cooling device, the door of which is open.

[0022] Figure 2 - is the partial perspective view of the cooling device.

[0023] Figure 3 - is the partial perspective view of the body and the compartment.

[0024] Figure 4 - is the perspective view of the cover and the locking mechanism.

[0025] Figure 5 - is the exploded view of the cover.

[0026] The elements illustrated in the figures are numbered as follows:

1. Cooling device

2. Body
3. Door
4. Compartment
5. Cover
6. Locking mechanism
7. Guide
8. Latch
9. Biasing means
10. Support member
11. Housing
12. Detent means
13. Recess
14. Fresh food compartment
15. Protrusion
16. Head portion
17. Concave portion

[0027] The cooling device (1) comprises a body (2), at least one door (3) providing access into the body (2), at least one compartment (4) situated inside the body (2) wherein foodstuffs are placed for cooling, a cover (5) providing access into the compartment (4) and a locking mechanism (6) that provides the cover (5) to remain in the locked position by locking. When the door (3) is closed, the cover (5) remains inside the body (2) and is not seen from the outside. First the door (3) then the cover (5) is opened in order to reach into the compartment (4). When closed, the door (3) and the cover (5) are in parallel positions with respect to one another. The cover (5), while open, can remain in this position and when closed, is prevented from opening automatically by being locked by means of the locking mechanism (6) (Figure 1, Figure 2).

[0028] In the cooling device (1) of the present invention, the locking mechanism (6) comprises a guide (7) disposed on the body (2) so as to correspond to one side of the cover (5) while the cover (5) is closed and a latch (8) rotatably mounted on the side of the cover (5), that passes behind the guide (7) by rotating when the cover (5) is closed and prevents

dislodgement of the cover (5) from the body (2). While the cover (5) is closed, the latch (8) first impacts the guide (7), afterwards passes behind the guide (7) by crossing over the guide (7) with the effect of the force applied on the cover (5). Thus, the cover (5) is locked in the closed position and the air inside the compartment (4) is provided to be insulated effectively. The cover (5) is pulled slightly to the front when desired to be opened and meanwhile the latch (8) changes the cover (5) to the free position by crossing over the guide (7). Since there is no connection member that directs the cover (5) towards the closed position, the cover (5) does not have to be held to remain open. And, this provides ease of utilization (Figure 3, Figure 4).

- [0029] In an embodiment of the present invention, the latch (8) and the guide (7) have curved surfaces that make moving over one another easy. In this embodiment, the corner points of the latch (8) and the guide (7) are rounded. Thus, the noises that are generated during locking decrease and a lesser amount of force is sufficient for the cover (5) to change to the closed position. This provides ease of utilization. Furthermore, quality perception of the user is increased by means of the smooth transition during the locking process.
- [0030] In a version of this embodiment, the guide (7) is configured in triangle shape with rounded corners such that the base thereof is positioned to be almost parallel to the base of the compartment (4). In this embodiment, the latch (8) moves between the front side and the rear side of the guide (7). The latch (8) moves over inclined surfaces while the cover (5) is both opened and closed by means of the triangle shape of the guide (7).
- [0031] In a version of this embodiment, the latch (8) comprises a head portion (16) that moves over the guide (7) while the cover (5) is opened/closed and a concave portion (17) wherein the guide (7) is seated when the cover (5) is closed. The head portion (16) extends downwards starting from the end of the concave portion (17) and thus when the concave portion (17) is seated on the peak point of the guide (7), the head portion (16) prevents the cover (5) from opening by bearing against the side of the guide (7) facing the rear wall of the compartment (4). When the cover (5) is pulled

for opening, the concave portion (17) is released from the peak point of the guide (7) and the head portion (16) crosses over the peak point by going backwards from the side borne against and resumes its free position.

[0032] In another embodiment of the present invention, the locking mechanism (6) comprises a biasing means (9), connected to the cover (5) from one end and to the latch (8) from the other end, applying pressure on the latch (8) at the moment the latch (8) starts to rotate so as to change the latch (8) to its initial position. The biasing means (9) is actuated from the moment the latch (8) starts rotating from its initial position and tries to change the latch (8) back to its initial position. The latch (8) that becomes free after crossing over the guide (7) changes to the initial position by effect of the prestress mean (9) and provides locking by being seated behind the guide (7) (Figure 3).

[0033] In a version of this embodiment, the locking mechanism (6) comprises a support member (10) whereon the latch (8) and the biasing means (9) are disposed. In this embodiment, the cooling device (1) comprises a housing (11) arranged on the cover (5) wherein the support member (10) is seated. During assembly, first of all, the latch (8) and the biasing means (9) are grouped into the support member (10), afterwards the support member (10) is seated into the housing (11). Consequently, the locking mechanism (6) does not have to be produced together with the cover (5) and thus both ease of production is provided and also cost advantage is maintained due to decreasing molding costs (Figure 5).

[0034] In a version of this embodiment, the support member (10) is detachably disposed into the housing (11). In this embodiment, furthermore the latch (8) and the biasing means (9) are also detachably mounted into the support member (10). Due to this modular structure, maintenance of the locking mechanism (6) is facilitated.

[0035] In another version of this embodiment, the cooling device (1) comprises at least one detent means (12) disposed on the support member (10) and at least one recess (13) arranged on the housing (11), wherein the detent means (12) is placed for providing the support member (10) to be fixed to the cover (5). In this embodiment, the detent means (12) is ramp shaped

and of resilient configuration. While the support member (10) is being placed into the housing (11), the detent means (12) moves along the recess (13) from the place whereat the slope begins until the maximum section and is seated into the recess (13) by being released from the surface of the housing (11) at the point of exact alignment with the recess (13). The detent means (12) prevents dislodgment of the support member (10) after the support member (10) is disposed into the housing (11) by means of its ramp shape and thus a strong connection is maintained (Figure 5).

- [0036] In an embodiment of the present invention, the cooling device (1) comprises a resilient protrusion (15) disposed at the rear surface of the guide (7) that provides the guide (7) to be fixed to the body (2). While the guide (7) is mounted to the body (2), the protrusion (15) is compressed from both sides and is inserted into the housing wherein it will be disposed. When released, the protrusion (15) presses on the walls of the housing wherein it is disposed by returning to its initial position due to its resilient structure and provides the guide (7) to be fixed. In this embodiment, the guide (7) and the protrusion (15) are produced from different materials.
- [0037] In an embodiment of the present invention, the cover (5) is rectangular that opens and closes by rotating around one of its sides. In this embodiment, the locking mechanism (6) is disposed on the side opposite to the side where the rotational axis of the cover (5) passes. The cover (5) is fixed rotatably to the body (2) preferably from one of its short sides and the locking mechanism (6) is disposed at the center section of the other short side.
- [0038] In an embodiment of the present invention, the cover (5) opens in the same direction as the door (3). Thus, even if the cover (5) is forgotten open, the door (3), when closed, provides to close the cover (5) by applying force thereon. Consequently, damaging of the cover (5) and/or the compartment (4) remaining open is prevented.
- [0039] In an embodiment of the present invention, the cooling device (1) comprises the compartment (4) having freezing features, disposed at the

upper part of the body (2), wherein objects to be frozen are placed, a fresh food compartment (14) disposed under the compartment (4), wherein objects to be cooled are placed, a cover (5) providing access into the compartment (4) and a door (3) providing access into the body (2). In this embodiment, the cooling device (1) is a single door refrigerator. The fresh food compartment (14) and the compartment (4) having temperature difference therebetween are used effectively inside the same body (2) by means of the cover (5) (Figure 1).

[0040] By means of the present invention, the cover (5) is closed firmly and the compartment (4) air is prevented from mixing into other sections inside the body (2). By means of the locking mechanism (6) configuration, the cover (5) is opened/closed easily and can remain open while the compartment (4) is used, without requiring any intervention. (6).

[0041] It is to be understood that the present invention is not limited to the embodiments disclosed above and a person skilled in the art can easily introduce different embodiments. These should be considered within the scope of the protection postulated by the claims of the present invention.

Claims

1. A cooling device (1) **comprising** a body (2), at least one door (3) providing access into the body (2), at least one compartment (4) disposed inside the body (2) wherein foodstuffs are placed for cooling, a cover (5) providing access into the compartment (4) and a locking mechanism (6) that provides the cover (5) to remain in the locked position by locking, **characterized by** the locking mechanism (6) having a guide (7) disposed on the body (2) so as to correspond to one side of the cover (5) while the cover (5) is closed and a latch (8) rotatably mounted on the side of the cover (5), that passes behind the guide (7) by rotating when the cover (5) is closed and prevents dislodgement of the cover (5) from the body (2).
2. A cooling device (1) as in Claim 1, **characterized by** the latch (8) and the guide (7) having curved surfaces that make moving over one another easy.
3. A cooling device (1) as in Claim 2, **characterized by** the guide (7) being configured in triangle shape with rounded corners such that the base thereof is positioned to be almost parallel to the base of the compartment (4).
4. A cooling device (1) as in Claim 3, **characterized by** the latch (8) comprising a head portion (16) that moves over the guide (7) while the cover (5) is opened and closed and a concave portion (17) wherein the guide (7) is seated when the cover (5) is closed.
5. A cooling device (1) as in any one of the above Claims, **characterized by** the locking mechanism (6) comprising a biasing means (9) connected to the cover (5) from one end and to the latch (8) from the other end, applying pressure on the latch (8) at the moment the latch (8) starts to rotate so as to change the latch (8) to its initial position.
6. A cooling device (1) as in Claim 5, **characterized by** the locking mechanism (6) comprising a support member (10) whereon the latch (8) and the biasing means (9) are disposed and a housing (11) arranged on the cover (5) and wherein the support member (10) is seated.
7. A cooling device (1) as in Claim 6, **characterized by** the support member (10) that is detachably disposed into the housing (11).
8. A cooling device (1) as in Claim 5, **characterized by** at least one detent means (12) disposed on the support member (10) and at least one recess (13)

arranged on the housing (11), wherein the detent means (12) is disposed, providing the support member (10) to be fixed to the cover (5).

9. A cooling device (1) as in any one of the above Claims, characterized by a resilient protrusion (15) disposed at the rear side of the guide (7) that provides the guide (7) to be fixed to the body (2).
10. A cooling device (1) as in any one of the above Claims, characterized by the rectangular cover (5) that opens and closes by rotating around one of the sides thereof and the locking mechanism (6) that is disposed on the side of the cover (5) opposite to the side where the rotational axis passes.
11. A cooling device (1) as in any one of the above claims, characterized by the cover (5) that opens in the same direction as the door (3).
12. A cooling device (1) as in any one of the above Claims, characterized by the freezing compartment (4) disposed at the upper section of the body (2), wherein objects to be frozen are placed, a fresh food compartment (14) disposed under the freezing compartment (4), wherein objects to be cooled are placed, a cover (5) providing access into the freezing compartment (4) and a door (3) providing access into the body (2).

Figure 1

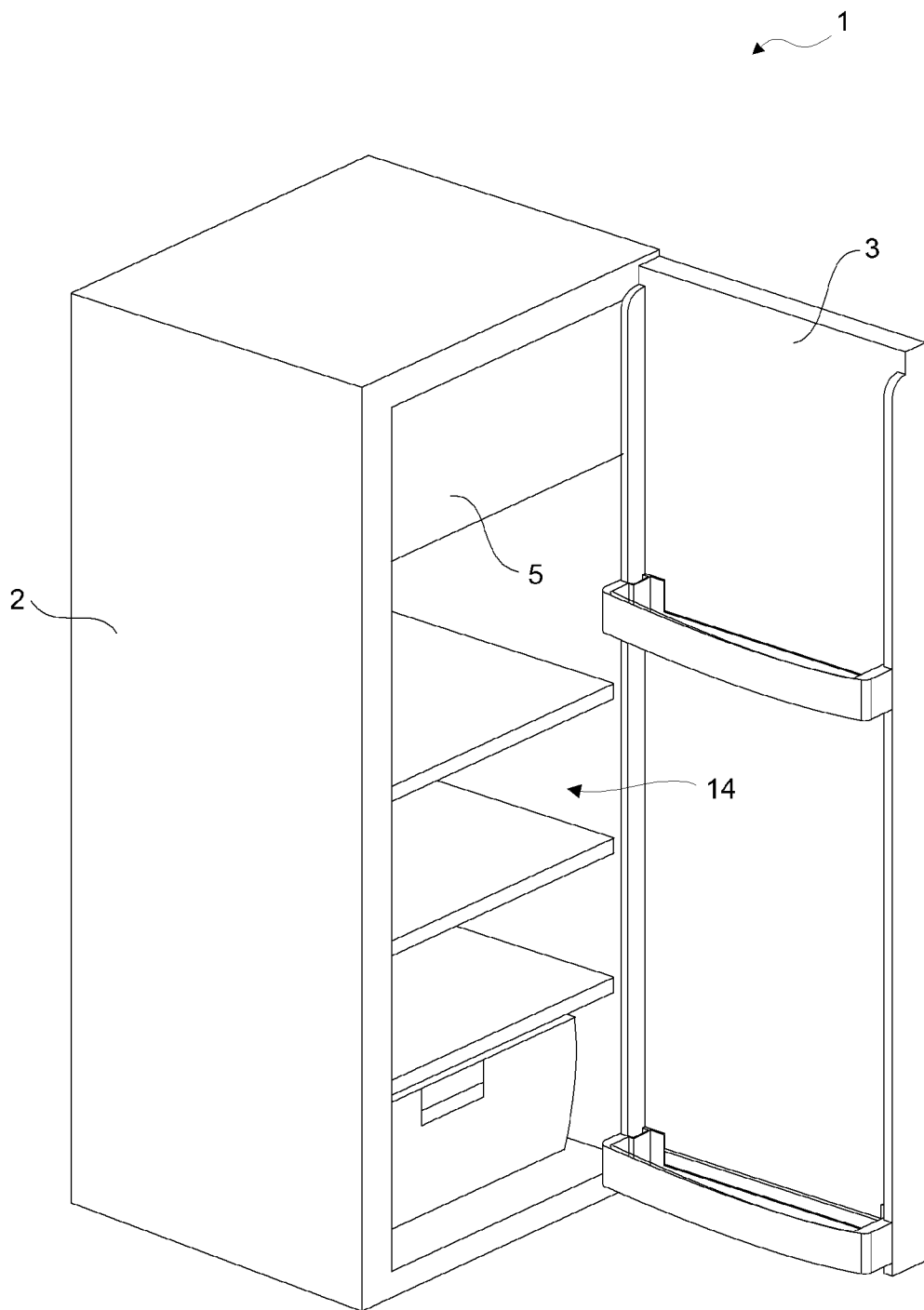

Figure 2

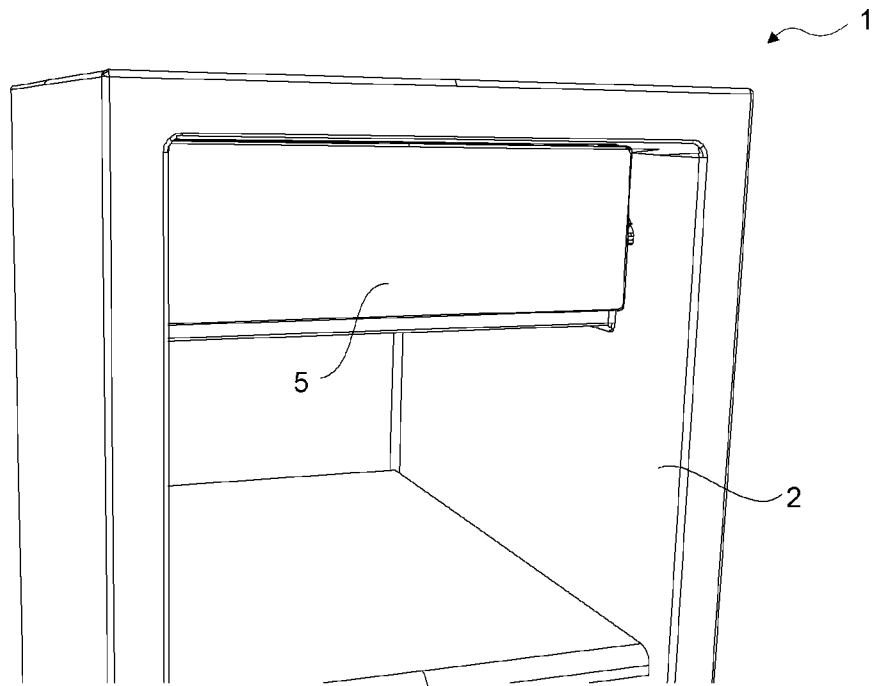

Figure 3

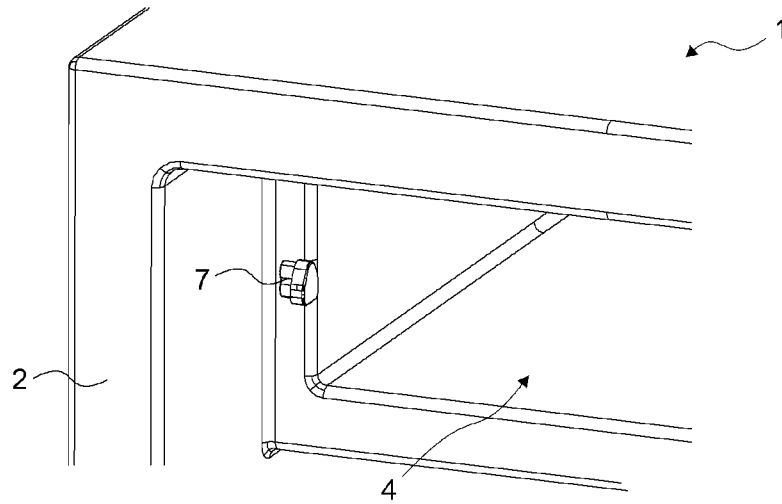

Figure 4

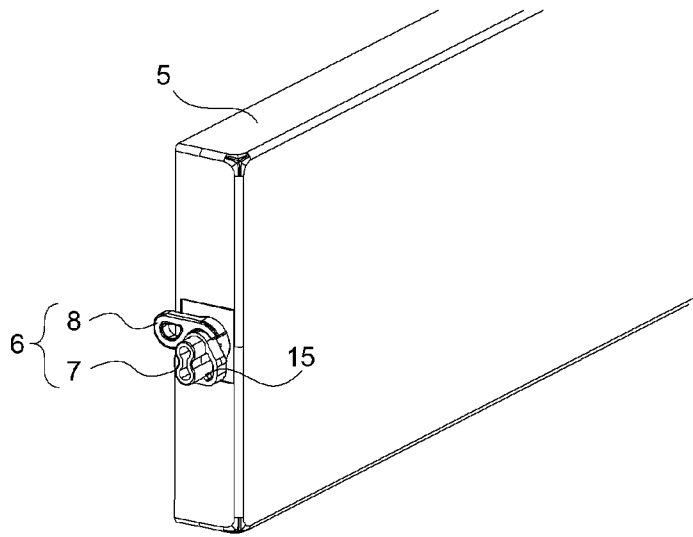

Figure 5

