

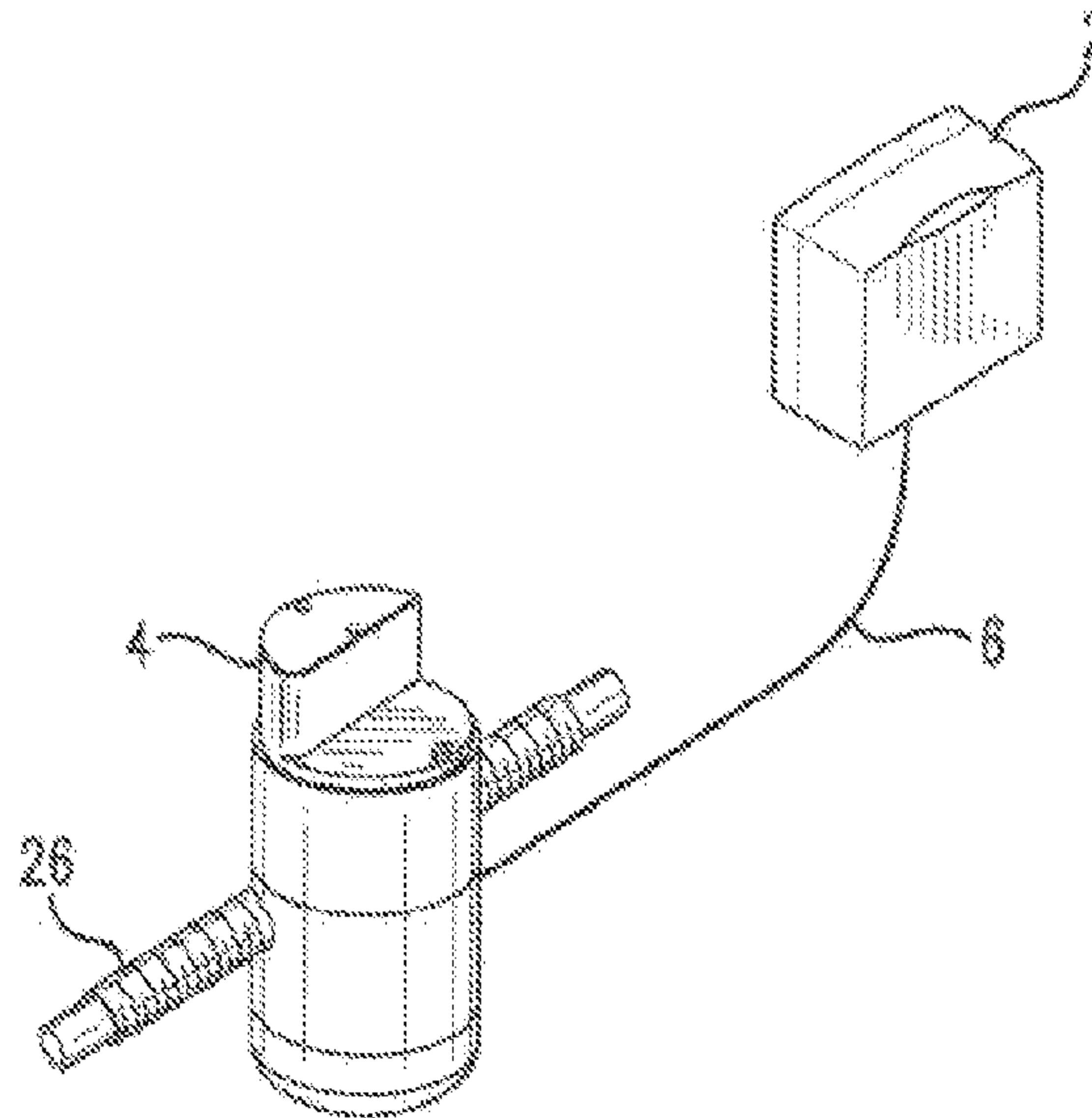

(86) Date de dépôt PCT/PCT Filing Date: 2008/06/13
(87) Date publication PCT/PCT Publication Date: 2008/12/24
(45) Date de délivrance/Issue Date: 2018/06/12
(85) Entrée phase nationale/National Entry: 2009/12/14
(86) N° demande PCT/PCT Application No.: US 2008/066883
(87) N° publication PCT/PCT Publication No.: 2008/157329
(30) Priorités/Priorities: 2007/06/15 (US60/944,326);
2007/08/23 (US60/957,486)

(51) Cl.Int./Int.Cl. *A61M 16/14* (2006.01),
A61M 16/00 (2006.01), *A61M 16/08* (2006.01)
(72) Inventeur/Inventor:
SPANDORFER, MICHAEL, US
(73) Propriétaire/Owner:
IDTX SYSTEMS, INC., US
(74) Agent: GOWLING WLG (CANADA) LLP

(54) Titre : SYSTEME DE DISTRIBUTION DE MEDICAMENT ET DE SURVEILLANCE POUR UN INSUFFLATEUR
(54) Title: A DRUG DELIVERY AND MONITORING SYSTEM FOR A VENTILATOR



(57) **Abrégé/Abstract:**

An automated drug delivery and monitoring system for use on mechanically ventilated patients in the intensive care unit is presented. Medication in the form of respirable particles is transported through ventilator circuitry by a delivery unit. Multiple medications may be delivered into the gas flow of the ventilator, with each medication delivered in a defined dose for a frequency and interval as specified by an operator. The particles mixed into the gas flow of the ventilator are inhaled and ingested by the patient's lungs.

(12) INTERNATIONAL APPLICATION PUBLISHED UNDER THE PATENT COOPERATION TREATY (PCT)

(19) World Intellectual Property Organization
International Bureau(43) International Publication Date
24 December 2008 (24.12.2008)

PCT

(10) International Publication Number
WO 2008/157329 A1(51) International Patent Classification:
A61M 16/00 (2006.01)

(21) International Application Number:

PCT/US2008/066883

(22) International Filing Date: 13 June 2008 (13.06.2008)

(25) Filing Language: English

(26) Publication Language: English

(30) Priority Data:

60/944,326	15 June 2007 (15.06.2007)	US
60/957,486	23 August 2007 (23.08.2007)	US

(71) Applicant and

(72) Inventor: SPANDORFER, Michael [US/US]; 2319 Portside Way, Charleston, SC 29407 (US).

(74) Agent: KILLOUGH, B., Craig; BARNWELL WHALEY PATTERSON & HELMS, LLC, P.O. Box Drawer H, Charleston, SC 29402 (US).

(81) Designated States (unless otherwise indicated, for every kind of national protection available): AE, AG, AL, AM, AO, AT, AU, AZ, BA, BB, BG, BH, BR, BW, BY, BZ, CA, CH, CN, CO, CR, CU, CZ, DE, DK, DM, DO, DZ, EC, EE, EG, ES, FI, GB, GD, GE, GH, GM, GT, HN, HR, HU, ID, IL, IN, IS, JP, KE, KG, KM, KN, KP, KR, KZ, LA, LC, LK, LR, LS, LT, LU, LY, MA, MD, ME, MG, MK, MN, MW, MX, MY, MZ, NA, NG, NI, NO, NZ, OM, PG, PH, PL, PT, RO, RS, RU, SC, SD, SE, SG, SK, SL, SM, SV, SY, TJ, TM, TN, TR, TT, TZ, UA, UG, US, UZ, VC, VN, ZA, ZM, ZW.

(84) Designated States (unless otherwise indicated, for every kind of regional protection available): ARIPO (BW, GH, GM, KE, LS, MW, MZ, NA, SD, SL, SZ, TZ, UG, ZM, ZW), Eurasian (AM, AZ, BY, KG, KZ, MD, RU, TJ, TM), European (AT, BE, BG, CH, CY, CZ, DE, DK, EE, ES, FI, FR, GB, GR, HR, HU, IE, IS, IT, LT, LU, LV, MC, MT, NL, NO, PL, PT, RO, SE, SI, SK, TR), OAPI (BF, BJ, CF, CG, CI, CM, GA, GN, GQ, GW, ML, MR, NE, SN, TD, TG).

Published:

— with international search report

(54) Title: A DRUG DELIVERY AND MONITORING SYSTEM FOR A VENTILATOR

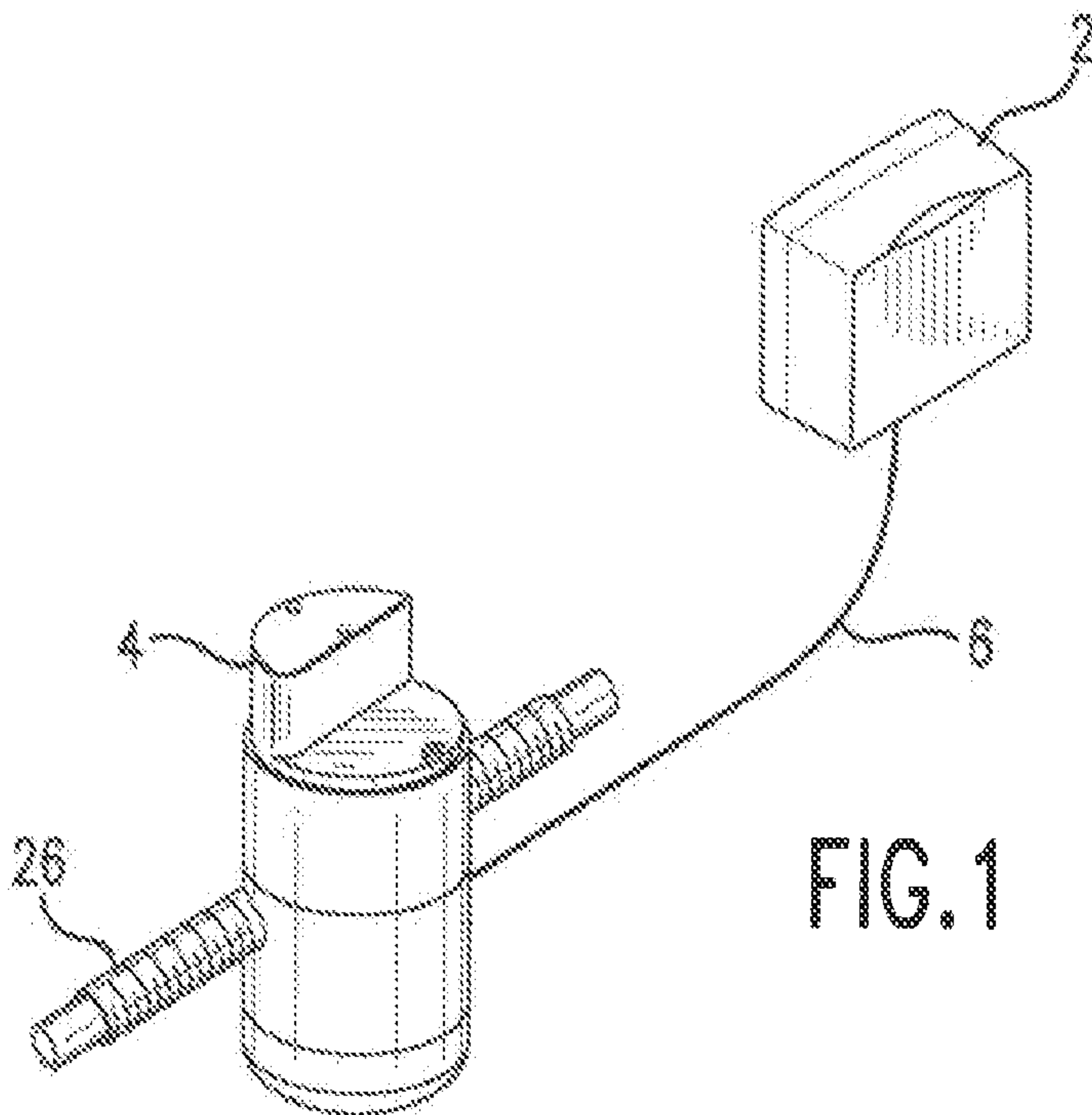

FIG. 1

(57) Abstract: An automated drug delivery and monitoring system for use on mechanically ventilated patients in the intensive care unit is presented. Medication in the form of respirable particles is transported through ventilator circuitry by a delivery unit. Multiple medications may be delivered into the gas flow of the ventilator, with each medication delivered in a defined dose for a frequency and interval as specified by an operator. The particles mixed into the gas flow of the ventilator are inhaled and ingested by the patient's lungs.

WO 2008/157329 A1

A DRUG DELIVERY AND MONITORING SYSTEM FOR A VENTILATOR

FIELD OF THE INVENTION

[002] This invention relates to ventilators and to drug delivery systems.

BACKGROUND OF THE INVENTION

[003] Mechanical ventilation is a method of mechanically assisting or replacing spontaneous breathing when patients cannot do so. One type of ventilation system employs the use of an endotracheal or tracheostomy tube secured into a patient's upper respiratory tract. Gas is mechanically delivered to the patient via the tube. In many cases, mechanical ventilation is used in acute settings such as an intensive care unit for a short period of time during a serious illness. Currently, the main form of mechanical ventilation is positive pressure ventilation, which works by increasing the pressure in the patient's airway and thus forcing additional air into the lungs. To aid in the treatment of ventilated patients, aerosol medicines are aspirated in situ through an access point in the ventilator system. This process is manual, requiring the medical professional to deliver the aerosols on a regular basis.

[004] Bronchodilator and corticosteroid medications for the treatment of reversible airway obstruction are often delivered via inhalation to the lower respiratory tract in both spontaneously breathing and mechanically ventilated patients. The devices typically used for delivery of aerosols to ventilated patients are small-volume nebulizers and pressurized metered-dose inhalers. Small-volume nebulizers and metered-dose inhalers can effectively deliver aerosols in a ventilator model and aerosol delivery can be significantly improved when a proper technique of administration is followed. To enhance lung deposition of aerosols from metered-dose inhalers, several accessory devices have been developed.

[005] The accessory devices most commonly used to deliver aerosols from metered-dose inhalers into ventilator circuits are inline non-chamber devices and inline holding chambers. The advantage of a holding chamber inserted in the ventilator circuit is that the actuated aerosol cloud is retained within the chamber and hence impaction of the drug within the ventilator circuit is reduced.

[006] Goals of this invention include reducing healthcare costs and improving patient safety by automatically administering medication to mechanically ventilated patients.

SUMMARY OF THE INVENTION

[007] An automated drug delivery and monitoring system for use on mechanically ventilated patients in the intensive care unit is presented. Medication in the form of respirable particles is transported through ventilator circuitry by a delivery unit. Multiple medications may be delivered into the gas flow of the ventilator, with each medication delivered in a defined dose for a frequency and interval as specified by an operator. The particles mixed into the gas flow of the ventilator are inhaled and ingested by the patient's lungs.

[008] The device combines monitoring and automated administration to facilitate control of drug delivery. The dispensed medications are preferred to be government approved and accepted as standard of care.

DESCRIPTION OF THE DRAWINGS

[009] **Figure 1** is a schematic view showing a control unit **2** connected to a delivery unit **4**.

[010] **Figure 2** is a perspective view of the delivery unit.

[011] **Figure 3** is a top plan view of the delivery unit.

[012] **Figure 4** is a sectioned view taken essentially along line A-A of **Figure 3**.

[013] **Figure 5** is a perspective view isolating an index table of a delivery unit and showing metered dose inhalers in position on the index table.

[014] **Figure 6** illustrates an embodiment of a control unit display.

[015] **Figure 7** is a schematic of an embodiment of the invention.

[016] **Figure 8** is a schematic illustrating control functions of an embodiment of the invention.

DESCRIPTION OF PREFERRED EMBODIMENTS

[017] A preferred embodiment of the invention is an automatic drug delivery device for mechanical ventilator tubing circuitry. Metered dose inhalers may be used to deliver drugs into the mechanical ventilator tubing circuitry. The metered dose inhalers may be aerosols. A control unit, which may incorporate a microprocessor, delivers the drugs or other therapeutic

agents at a specified time, frequency, dose, and flow triggered to maintain a monitored and consistent delivery of medicaments into the air stream. The device may provide multiple ports to hold and dispense aerosols, which may be in the form of metered dose inhalers. Indicators on an operator interface panel may display delivery and status information, and provide configuration capability to the operator. Patient identification, date, time, medication type, and dose may be logged by the system and can be used for dosage reporting. “Drug” and “medicine” as used herein can mean a drug, medicine, medicament or therapeutic agent dispensed by the device for patient inhalation as delivered through the ventilator circuit.

[018] In one embodiment a control unit **2** communicates with a delivery unit **4**. **Figure 1**. These components may be linked via a cable **6** carrying both serial communications and power between them. Power may be provided to the operator interface panel via a medical grade AC to DC power supply. A battery system, such as an uninterruptable power source, allows the device to function during times of AC power interruption. The delivery unit, and the point of medication, is preferred to be positioned relatively near the patient, while the control unit may be positioned further away from the patient, which is facilitated by cable **6**. The lower voltage DC current of the preferred control unit allows it to be hand held.

[019] The control unit **2** may contain an operator interface panel. The control unit may comprise a microprocessor. The operator interface panel will typically provide for operator input, and will provide output to the delivery unit **4**, and it may provide data output. The control unit may be separated from the delivery unit by a power/control cable **6**. This configuration facilitates access to the programming features of the system and reduces the size and weight of the section that needs to be in close proximity to the patient and ventilator tubing.

[020] The delivery unit may directly interface with the sensing and control hardware for delivery of medicaments to the air stream. Operation of the delivery unit is under command and

control of the control unit, which may be via a serial communications link. The interface provides a means of manual control, status, and data transfer from the operator interface panel.

[021] The delivery unit may be contained in a housing. The housing **8** protects the delivery unit, and also limits access to the drugs or medicaments contained in the housing. The housing may be designed to be tamper-proof, so that it is accessible by hospital staff, such as by providing a lock **12**. The top panel **10** of the housing allows access to the internal mechanism of the delivery unit so that drugs may be replaced or replenished. In one embodiment, drugs or other therapeutic agents are delivered in an aerosol form, and the drugs or agents may be delivered by metered dose inhalers.

[022] **Figure 4** is a sectioned view of the delivery unit, which is cut away to show internal features of an embodiment of the delivery unit. This embodiment of the delivery unit includes a rotatable index table **14**. A rotation device **16** is used to rotate the index table as controlled by the control unit. The rotation device could be a motor, such as a stepper motor, or a rotary solenoid. This rotation device communicates with the index table to rotate the index table by a shaft that rides in a support bearing **18**. A coupling **20** may be used to couple the shaft **22** to the rotation device.

[023] An agitator or shaker may be integrated into the index table. Many medications must be agitated before delivery. The control unit causes the agitator to agitate the medication just prior to delivery according to the selected interval for delivery of the particular medication.

[024] Linear actuator **24** may be disposed above a metered dose inhaler **30A** that is rotated into position by the index table. The metered dose inhalers exemplified by **30A**, **30C** are selectively rotated by the index table, as controlled by the control unit, to be in position above the conduit **26** of the mechanical ventilator tubing circuitry. The linear actuator, which may be a linear solenoid, is connected to an actuator, such as actuation jaws **28**. In the embodiment shown, the solenoid, acting through the actuation jaws, applies a downward force

to the metered dose inhaler **30A**. A valve **42** of the metered dose inhaler is opened and dispenses a metered dose into the conduit of the mechanical ventilator tubing circuitry. The control unit times actuation so that the drug or agent is dispensed while the flow of gas through the conduit is toward the patient; that is, while the patient inhales.

[025] The linear actuator may have a position sensor **40** that verifies the position of the linear actuator. This sensor verifies movement of the linear actuator to deliver a dose, and verifies return of the linear actuator after actuation. Return of the linear actuator and the actuation jaws is critical to positioning of the index table for receiving the required metered dose inhaler.

[026] The delivery unit communicates with a conduit **26** that is part of the mechanical ventilator tubing circuitry. The conduit communicates with the index table as shown.

[027] A plurality of metered dose inhalers is present in the delivery unit. As is shown in **Figure 5**, in one embodiment of the invention, four (4) metered dose inhalers engage the index table. Fewer than four metered dose inhalers may be used with the device as shown in the drawings. The device could be designed for more than four metered dose inhalers.

[028] As shown in **Figure 4**, a non-metal, non-allergic deformable insert **32** is present within the index table. The insert may be formed of plastic, synthetic rubber or similar deformable materials. Not all metered dose inhalers are of identical dimensions at the valve. The insert is deformable, and allows metered dose inhalers and other similar dispensers of various sizes and configurations to be used with the device. Rubber inserts configured for a particular dispenser may be used with the index table.

[029] In another embodiment, a manifold is used rather than the index table. The manifold may receive a plurality of metered dose inhalers, such as four (4) metered dose inhalers. In this embodiment, the manifold has four inlets, and a single outlet, with the single

outlet communicating with the conduit of the mechanical ventilator tubing circuitry. In another embodiment, the device could have an equal number of inlets and outlets.

[030] In one embodiment, four linear actuators, each with associated actuation jaws, may be used to selectively actuate the metered dose inhalers. The number of linear actuators will correspond to the number of inlets in the manifold for drug dispensing. The manifold may arrange the metered dose inhalers in an "in line" configuration, or other geometric configurations such as "V" and radial arrangements. The advantage of the index table over the manifold is believed to be that the metered dose inhaler to be actuated may be placed directly above, and in close approximation to, the conduit, leading to an efficient dispensing of the medication as opposed to a manifold, which prevents possible mixing of drugs within a manifold. The use of the insert **32** also allows the device to be cleaned by simply replacing the insert, as opposed to cleaning a manifold into which a plurality of drugs or other materials are dispensed. However, the use of a manifold means that a rotary device is not required, and operation of the device is simplified. The manifold is preferred to have an agitator or shaker for agitating the medication prior to delivery.

[031] The delivery unit may continuously monitor the air pathway flow via a gas flow sensor **34**. A flow profile may be established that contains frequency, peak flow, peak flow timing, and duration for both inhalation and exhalation.

[032] Dosage delivery timers are preferred to be maintained for each port. Delivery frequency information may be calculated and configured by the control unit. Dosage counters are preferred to be maintained, with this information conveyed from the delivery unit to the control unit. The dose release sensor **36** may be monitored to detect if the aerosol was delivered into the air stream.

[033] The delivery unit is preferred to have a sensor **44** to determine if an index position presents a drug canister, such as a metered dose inhaler canister. The sensor may be part of the index table.

[034] The delivery unit is preferred to comprise an index sensor **38**. The index sensor verifies the position of the index table and the associated drug or agent.

[035] A gas flow sensor **34** is preferred to be used. The gas flow sensor communicates with the conduit. The gas flow sensor measures the direction of flow of gas through the conduit. The gas flow sensor may measure the pressure and/or the rate of change of pressure in the conduit, and may measure other gas flow characteristics such as volumetric gas flow rate and temperature. A primary function of the gas flow sensor is to communicate with the control unit to indicate the direction of flow of gas through the conduit. The release of the drug or agent into the conduit should be timed so that the drug or agent flows with the gas toward the patient. Upon actuation, the air pathway may be monitored by the gas flow sensor to detect the start of the mechanical ventilator gas delivery (inhale). The port may be actuated and the dosage delivered to the conduit at the optimum flow delivery point. The control unit actuates the metered dose inhaler or other device so that drug or agent is released when the flow of gas in the conduit is toward the patient.

[036] The delivery unit signals the control unit to restart the port timer and decrements the dosage counter. The process repeats until commanded to stop or the aerosol cartridge is emptied. Indicators on the delivery unit may indicate actuation, status, alarm and exceptional conditions.

[037] The gas flow sensor, or an additional sensor, may be used to measure pressure and/or the rate of change of pressure in the conduit, and may measure other gas flow characteristics such as volumetric gas flow rate and temperature, that indicate the patient's

ability to receive the drug or agent. The gas flow sensor measures circuit conditions and patient airway resistance, which may be used to determine the need for additional medication dosing and timing or modulation of the current specified dosing and timing of the medication. Higher pressure and/or a relatively short cycle time on reversal of gas flow indicate that the ability of the patient to consume the drug or agent through the lungs is impaired. In such case, the control unit may be programmed to increase the dosage frequency to the patient. The programming may occur manually or automatically by an algorithm utilized by the control unit.

[038] The delivery unit may comprise a dose release sensor **36**. This sensor verifies that a dose of a drug or agent was actually dispensed and delivered. Verification may be provided and recorded in a data base collection at the control unit or another computer that is in communication with the delivery unit. Similarly, data from other sensors as disclosed herein may be collected and stored in a data base at the control unit or in another computer drive or storage device.

[039] A spectrometer may be disposed in the conduit. The spectrometer measures ultraviolet, optical and near-infrared spectra to determine particle size reflectance and deposition/detection. Raman spectroscopy and optical frequency comb spectroscopy may be incorporated. The spectrometer may be placed at the distal end of the device. The device may also analyze device/ventilator and patient effluent gases.

[040] A dedicated industry standard serial communications interface may communicate with the delivery unit. The protocol may be ASCII text based, with sufficient checks to verify message delivery and integrity. A USB interface may provide operator updates of the medications database, and provide patient information and system logs. An Ethernet interface to the control unit may provide remote access from other computer systems for remote monitoring and configuration upload/download. **Figure 7.**

[041] An operator interface panel **50** may comprise a touch screen, flat panel display that will be used to control the delivery unit, and to display system status. **Figure 6.** The panel and control unit may allow configuring drug dispensing, such as inputting the desired delivery time and frequency of the plurality of drugs present in the delivery unit. The control unit may maintain logs of usage, medications delivered to the patient, and a drug configuration library.

[042] The operator interface panel may comprise visual data on the screen. A status of each delivery port of the delivery unit is provided. The information may include the number of doses remaining, time to next actuation, frequency of delivery, delivery status, and a manual actuation control.

[043] A menu may display control and configuration selections. A configuration screen may provide controls and methods for configuring the operator interface panel or delivery unit components. The drug database screen will allow monitoring and maintenance of the drug identification, dosage and delivery frequency. The operator may amend entries into the data base. Entries in this database are for use on the main screen when selecting drugs or agents for the delivery port. A reporting screen may display statistics/logs concerning delivery of medications by the system overall and on a per-patient basis. Printing, upload/download will be options provided to the operator. Status/Service screen provides detailed status and diagnostic information about the system. Low level access may be provided through this screen.

[044] The operator interface may comprise a computer with the following components and interfaces: 1) nonvolatile memory for both dosing schedules and dosing data logging; 2) bi-directional serial interface for communicating with the delivery unit. 3) USB interface for data transfer; 4) Ethernet interface for remote monitoring and configuration; 5) touch screen input interface; 6) a color Liquid Crystal Display (LCD) interface; 7) a battery backed real-time clock shall provide a reference for scheduled dosing events; 8) a barcode reader for patient and

medication identification, with input into the control unit, hospital databases and/or medication administration records. Output to the operator may be provided by a LCD. Input from the operator may be provided by a touch screen integrated with the LCD.

What is claimed is:

1. A drug delivery and monitoring system for a ventilator, comprising:
 - a delivery unit;
 - a gas conduit held by the delivery unit that is attached to ventilator tubing of a ventilator tubing circuit of the ventilator;
 - a plurality of metered dose inhaler (“MDI”) canisters that are concurrently attached to the delivery unit and are configured to selectively communicate with said gas conduit;
 - at least one actuator held by the delivery unit that selectively actuates to cause at least one of said plurality of MDI canisters to dispense medicine into said gas conduit;
 - a control unit in communication with the at least one actuator that causes said at least one actuator to automatically actuate to cause each of said plurality of MDI canisters to dispense medicine into said gas conduit in a defined sequence at defined intervals, wherein the control unit is configured to automatically direct the at least one actuator to cause one or more of the canisters to dispense (i) at a different dose amount from a prior amount, (ii) at an adjusted dose frequency or (iii) at a different dose amount and frequency from a prior amount and frequency; and
 - a display in communication with the control unit that provides an operator interface and presents, for a respective MDI canister, a number of doses remaining, time to next actuation, frequency of delivery and delivery status,
 - wherein said plurality of MDI canisters are circumferentially spaced apart and engage an index table, wherein said index table rotates at defined intervals as signaled by said control unit, and wherein the MDI canisters are concurrently held by the index table so as to be substantially orthogonal and adjacent to said gas conduit at a medicine dispensing location, wherein at least one of the canisters has a different medicine than another one of the canisters.
2. The drug delivery and monitoring system for a ventilator of Claim 1, further comprising a flow sensor that monitors gas flow in said ventilator tubing and is in communication with the control unit to selectively actuate the at least one actuator to dispense medicine from a selected MDI canister into said gas conduit only when a direction of gas flow is toward a patient and thereby inhibits said actuator from actuating when gas flow is away from the patient.
3. The drug delivery and monitoring system for a ventilator of Claim 2, further comprising a release sensor that is in fluid communication with the gas conduit that communicates with said control unit and signals a dose was successfully dispensed from a respective MDI canisters.

4. The drug delivery and monitoring system for a ventilator of Claim 1, further comprising a gas flow resistance sensor in communication with the control unit to determine a pressure and volume of gas flow through said gas conduit so that the control unit can determine patient airway resistance and/or a cycle time on reversal of gas flow to assess whether the patient has an impaired ability to intake medicament from at least one of the MDI canisters through the lungs, wherein the control unit automatically increases a dosage frequency or dosage amount or both dosage frequency and amount for at least one of the MDI canisters when it determines that the patient has the impaired ability.

5. The drug delivery and monitoring system for a ventilator of Claim 1, further comprising a sensor that continuously detects ventilator circuit conditions and/or patient airway resistance, wherein said control unit modifies an interval of actuation of the at least one actuator for one or more of the MDI canisters in response to a change in gas pressure in the ventilator circuit.

6. The drug delivery and monitoring system for a ventilator of Claim 1, further comprising an automated agitator held by the delivery unit that physically shakes or vibrates a respective MDI canister prior to actuation to dispense medicine into said gas conduit.

7. The drug delivery and monitoring system for a ventilator of Claim 1, wherein the index table directly contacts and concurrently supports the MDI canisters and includes at least one flow passage in fluid communication with the gas conduit, wherein the gas conduit that is attached to the ventilator tubing circuit extends laterally outward a distance beyond opposing sides of the delivery unit and index table.

8. The drug delivery and monitoring system for a ventilator of Claim 1, wherein said plurality of MDI canisters each comprise an onboard valve that can be automatically actuated by depressing said valve using the at least one actuator, wherein the canisters are configured to selectively spray medicine out of respective canisters into an adjacent axially extending gas flow stream in said gas conduit then into a patient body using the ventilator tubing circuit.

9. The drug delivery and monitoring system for a ventilator of Claim 1, wherein each of said MDI canisters comprises a valve, and wherein each of said valves is automatically actuated by depressing said valve using the at least one actuator, wherein said at least one actuator is a single actuator that selectively communicates with each valve and actuates a respective valve by depressing said valve at defined intervals.

10. The drug delivery and monitoring system for a ventilator of Claim 1, wherein said control unit counts dosages dispensed from each of said plurality of MDI canisters and electronically provides a graphic output of dispensed dose data illustrating dose amounts

remaining proximate the number of doses remaining for each of the MDI canisters to a panel associated with the display.

11. The drug delivery and monitoring system for a ventilator of Claim 1, wherein the system is configured to analyze patient effluent gases.

12. The drug delivery and monitoring system for a ventilator of Claim 1, wherein said operator interface concurrently provides visual information for each of said plurality of MDI canisters.

13. The drug delivery and monitoring system for a ventilator of Claim 1, wherein said control unit comprises an operator interface panel, and wherein said operator interface panel provides visual information for each of said plurality of MDI canisters, wherein said control unit comprises a dosage counter and said information comprises information regarding remaining dosages for each of said plurality of MDI canisters including a graphic display of a remaining volume or dose amount relative to a full volume capacity, and wherein said information comprises information regarding an interval between dosages for each of said MDI canisters.

14. The drug delivery and monitoring system for a ventilator of Claim 1, wherein said control unit comprises an operator interface panel, wherein said operator interface panel comprises an input for an interval between dosages for each of said MDI canisters, and wherein the system includes at least one sensor that continuously monitors the ventilator circuit airflow path during inhalation and exhalation.

15. The system of Claim 1, wherein the gas conduit is axially in-line with the ventilator tubing.

16. A drug delivery and monitoring system for a ventilator, comprising:
a delivery unit;
a gas conduit held by the delivery unit that is attached to ventilator tubing of a ventilator tubing circuit of the ventilator;
a plurality of metered dose inhaler (“MDI”) canisters that are concurrently attached to the delivery unit and are configured to selectively communicate with said gas conduit;
at least one actuator held by the delivery unit that selectively actuates to cause at least one of said plurality of MDI canisters to dispense medicine into said gas conduit;
a control unit in communication with the at least one actuator that causes said at least one actuator to automatically actuate to cause each of said plurality of MDI canisters to dispense medicine into said gas conduit in a defined sequence at defined intervals, wherein the control unit is configured to automatically direct the at least one actuator to cause one or more of the canisters to dispense (i) at a different dose amount from a prior amount, (ii) at an adjusted dose

frequency or (iii) at a different dose amount and frequency from a prior amount and frequency;
and

a display in communication with the control unit that provides an operator interface and presents, for a respective MDI canister, a number of doses remaining, time to next actuation, frequency of delivery and delivery status,

wherein the delivery unit comprises a manifold, and wherein said plurality of MDI canisters include onboard valves and are held upright by the manifold with the respective valves received into spaced apart, fluid paths in the manifold, wherein said manifold rotates and is in fluid communication with said gas conduit, and wherein the MDI canisters are concurrently held upright, adjacent and substantially orthogonal to said gas conduit at a medicine intake location into the gas conduit.

17. A drug delivery and monitoring system for a ventilator, comprising:
a delivery unit;

a gas conduit held by the delivery unit that is attached to ventilator tubing of a ventilator tubing circuit of the ventilator;

a plurality of metered dose inhaler (“MDI”) canisters that are concurrently attached to the delivery unit and are configured to selectively communicate with said gas conduit; at least one actuator held by the delivery unit that selectively actuates to cause at least one of said plurality of MDI canisters to dispense medicine into said gas conduit;

a control unit in communication with the at least one actuator that causes said at least one actuator to automatically actuate to cause each of said plurality of MDI canisters to dispense medicine into said gas conduit in a defined sequence at defined intervals, wherein the control unit is configured to automatically direct the at least one actuator to cause one or more of the canisters to dispense (i) at a different dose amount from a prior amount, (ii) at an adjusted dose frequency or (iii) at a different dose amount and frequency from a prior amount and frequency;
and

a display in communication with the control unit that provides an operator interface and presents, for a respective MDI canister, a number of doses remaining, time to next actuation, frequency of delivery and delivery status,

wherein the delivery unit further comprises a lockable housing that encloses the MDI canisters and at least part of the gas conduit and is configured so that ventilator tubing from the ventilator tubing circuit attaches to opposing end portions of the gas conduit and extends laterally away from both sides of the housing, wherein said plurality of MDI canisters are held upright in the housing by a manifold, the manifold defining internal fluid flow paths that engage the gas conduit, wherein said manifold rotates, wherein rotation of said manifold is controlled by said control unit to rotate said manifold at defined intervals, and wherein the MDI canisters are concurrently held adjacent and substantially orthogonal to said gas conduit at a medicine intake location into said gas conduit, and wherein the canisters are configured to selectively spray

medicine out of respective canisters into at least one of the manifold internal flow paths, then to the gas conduit to deliver the medicine to the ventilator tubing circuit.

18. A drug delivery and monitoring system for a ventilator, comprising:
a delivery unit;
a gas conduit held by the delivery unit that is attached to ventilator tubing of a ventilator tubing circuit of the ventilator;
a plurality of metered dose inhaler ("MDI") canisters that are concurrently attached to the delivery unit and are configured to selectively communicate with said gas conduit;
at least one actuator held by the delivery unit that selectively actuates to cause at least one of said plurality of MDI canisters to dispense medicine into said gas conduit;
a control unit in communication with the at least one actuator that causes said at least one actuator to automatically actuate to cause each of said plurality of MDI canisters to dispense medicine into said gas conduit in a defined sequence at defined intervals, wherein the control unit is configured to automatically direct the at least one actuator to cause one or more of the canisters to dispense (i) at a different dose amount from a prior amount, (ii) at an adjusted dose frequency or (iii) at a different dose amount and frequency from a prior amount and frequency;
and
a display in communication with the control unit that provides an operator interface and presents, for a respective MDI canister, a number of doses remaining, time to next actuation, frequency of delivery and delivery status,
wherein said plurality of MDI canisters are held upright by an index table in a lockable enclosure with respective valves residing in a fluid flow path extending downward through the index table, and wherein said index table rotates about a vertical axis of rotation.

19. A drug delivery and monitoring system for cooperating with a ventilator, comprising:
a gas conduit in fluid communication with a ventilator gas flow circuit of the ventilator;
a plurality of metered dose inhaler ("MDI") canisters, each having an onboard valve;
an actuator that selectively actuates said plurality of MDI canisters to dispense medicine into said gas conduit while flow of gas through the conduit is toward a respective patient;
at least one sensor in communication with the gas conduit configured to monitor pressure over inhalation and exhalation, and at least one of patient airway resistance or cycle time on reversal of gas flow associated with a patient's impaired ability to receive medicine dispensed from one or more of the MDI canisters through lungs of the patient;
a control unit that (i) causes said actuator to actuate each of said plurality of MDI canisters in a defined sequence at defined intervals only when gas flow is toward the patient based on input from the at least one sensor and (ii) increases dosage frequency of one or more of the MDI canisters to the patient if data from the at least one the sensor identifies a respective patient as having an impaired ability to receive the agent in the lungs;

a display in communication with the control unit that provides an operator interface that (a) allows a user to select delivery time and frequency of different drugs from respective MDI canisters held by the table or manifold and (b) presents, for each MDI canister, a number of doses remaining, time to next actuation and frequency of delivery;

a housing enclosing the MDI canisters;

a rotatable indexing table or manifold inside the housing that concurrently holds the MDI canisters upright and oriented with respective valves of each MDI canister facing the table or manifold, wherein the MDI canisters are pressed toward respective onboard valves by the at least one actuator to release metered doses of medicine, wherein the table or manifold rotates about a vertical axis and resides above and closely spaced to the gas conduit, and wherein the table or manifold includes at least one flow passage in fluid communication with the gas conduit; and

a shaft attached to a medial portion of the table or manifold and extending below the table or manifold to a motor to rotate the table or manifold, wherein the conduit resides between the motor and the table or manifold.

20. The system of Claim 19, wherein the housing enclosure is a lockable enclosure that holds the MDI canisters and the gas conduit, and wherein the gas conduit connects to ventilator circuit tubing and is axially in-line with the ventilator circuit tubing and the tubing or gas conduit extends laterally outward from opposing sides of the enclosure.

21. The system of Claim 20, wherein the actuator comprises at least one linear actuator that resides in the enclosure above the MDI canisters and, in operation, is in communication with a respective MDI canister and the control unit to cause the at least one linear actuator to depress the MDI canister to dispense a metered aerosolized dose of medicament.

22. The system of Claim 19, wherein the control unit is configured to populate a database of medical records including medication type, dose frequency and verification of medication delivered to a patient.

23. The system of Claim 19, wherein the control unit is configured to provide electronic data records of patient physiologic parameters detected by the at least one sensor including a flow profile that contains frequency, peak flow, peak flow timing, patient airway resistance and duration for inhalation and exhalation.

24. The system of Claim 19, wherein the system is configured to analyze patient effluent gases.

25. An automated medical system for controlling medication dispensed to a ventilator circuit that extends between a mechanical ventilator and a patient, comprising:

a gas conduit having axially opposing first and second ends, each end being in-line with and adapted to attach to spaced apart segments of tubing of the ventilator circuit to form part of the ventilation circuit;

at least one pressurized metered dose inhaler (pMDI) canister held orthogonal to the gas conduit with a dispensing end of the pMDI canister held proximate the gas conduit in fluid communication with the ventilator circuit via the gas conduit;

an actuator in communication with the at least one pMDI canister to press against the at least one pMDI canister to release medication from the dispensing end to the gas conduit then into the tubing of the ventilator circuit;

a housing holding the gas conduit, the at least one pMDI canister and the actuator;

a control unit residing away from the housing and attached to the housing by a cable, the control unit comprising an operator interface configured to allow an operator to adjust dosage and schedule medication dispensing for each of the at least one pMDI canister and to actuate the actuator to dispense medication from each of the at least one pMDI canister to the ventilator circuit at a defined dosage, delivery time and/or frequency, wherein the control unit monitors air pathway flow in the ventilator circuit and is configured to time actuation of the actuator so that medication from the at least one pMDI canister is released from the at least one pMDI canister only during an inspiratory/inhale cycle with gas flow toward the patient; and

a display held by the control unit for displaying parameters including number of doses remaining for each of the at least one pMDI canister.

26. The system of Claim 25, wherein the control unit operator interface is a touch screen input provided by the display.

27. The system of Claim 26, wherein the operator interface comprises a manual actuation input on the display to thereby allow a user to electronically initiate actuation of the actuator.

28. The system of Claim 25, wherein actuator resides above the gas conduit in the housing, and wherein a delivery path from the dispensing end of the at least one pMDI canister is directly into an axially extending flow path that is in-line with of the gas conduit.

29. The system of Claim 25, wherein the actuator is configured to push down against the at least one pMDI canister to release the medication from the at least one pMDI canister.

30. The system of Claim 25, wherein the at least one pMDI canister is a plurality of spaced apart pMDI canisters that are held in the housing, and wherein the control unit is configured to direct the at least one actuator to serially actuate the plurality of pMDI canisters.

31. The system of Claim 25, wherein the control unit comprises a dosage counter and a clock, and wherein the dosage counter decrements a count in response to actuation of the actuator or a respective pMDI canister to provide the number of doses remaining.

32. The system of Claim 25, wherein the housing is a delivery unit that is in close proximity to the patient and ventilator tubing.

33. The system of Claim 25, wherein the control unit is a hand-held control unit.

34. The system of Claim 25, wherein the system is configured to analyze patient effluent gases, wherein the control unit automatically increases or decreases a dosage frequency or dosage amount or both dosage frequency and amount for the at least one pMDI canister based on that analyzed patient effluent gases.

35. The system of Claim 25, further comprising a gas flow resistance sensor in communication with the control unit to determine a pressure and volume of gas flow through said gas conduit so that the control unit can determine patient airway resistance and/or a cycle time on reversal of gas flow to assess whether the patient has an impaired ability to intake medicament from the at least one pMDI canister through the lungs, wherein the control unit automatically increases a dosage frequency or dosage amount or both dosage frequency and amount for the at least one pMDI canister when it determines that the patient has the impaired ability.

36. The system of Claim 25, further comprising a sensor that continuously detects ventilator circuit conditions and/or patient airway resistance, wherein said control unit modifies an interval of actuation of the at least one actuator for the at least one MDI canister in response to a defined change in gas pressure in the ventilator circuit.

37. The system of Claim 25, wherein the control unit comprises an Ethernet interface to provide remote access to one or more other computers for remote monitoring and/or upload/download.

38. The system of Claim 25, wherein the system and/or control unit comprises a log of usage, medications dispensed to the patient by the system and a drug configuration library.

39. The system of Claim 25, wherein the control unit operator interface comprises a menu with control and configuration selections, and wherein the display presents, for a

respective MDI canister, a number of doses remaining, time to next actuation, frequency of delivery and delivery status.

40. The system of Claim 25, wherein the at least one pMDI canister is a plurality of pMDI canisters that can be serially and selectively actuated by the at least one actuator, the system further comprising an automated agitator held by the housing that physically, and external to the pMDI canisters, shakes or vibrates a pMDI canister prior to actuation to dispense medicine into the gas conduit.

41. The system of Claim 25, wherein the control unit operator interface provides visual information for each of the at least one MDI canister, wherein said control unit comprises a dosage counter and the visual information comprises a graphic display of a remaining volume or dose amount relative to a full volume capacity, and wherein the visual information comprises information regarding an interval between dosages for each of the at least one MDI canister.

42. The system of Claim 25, wherein the operator interface comprises a user input for an interval between dosages for each of the at least one MDI canisters, and wherein the control unit receives data from at least one sensor that continuously monitors the ventilator circuit airflow path during inhalation and exhalation.

43. The system of Claim 25, wherein the control unit is configured to populate a database of medical records to provide dispensed medication type, dose frequency and verification of medication dispensed to a patient.

44. The system of Claim 25, wherein the control unit is configured to provide electronic data records of patient physiologic parameters including a flow profile that contains peak flow, peak flow timing, patient airway resistance and duration for inhalation and exhalation.

45. A drug delivery and monitoring system for a ventilator, the system comprising;
a gas conduit that communicates with a ventilator;
a plurality of medicine containers that communicate with said gas conduit, each medicine container comprising a valve, wherein each valve is actuated by depressing said valve;
an actuator that selectively actuates said plurality of medicine containers to cause said medicine containers to dispense medicine into said gas conduit; and
a control unit that causes said actuator to actuate each of said plurality of medicine containers in a defined sequence at defined intervals, characterized in that the system further comprises a flow sensor that monitors gas flow in said gas conduit and permits said actuator to actuate a medicine container *to* cause said medicine container to dispense medicine into said gas conduit when a direction of gas flow in said gas conduit is toward a patient and inhibits said actuator from actuating said medicine container when gas flow in said gas conduit is away from

the patient, wherein the control unit comprises an operator interface panel which provides visual information for each of the plurality of medicine containers, including a number of doses remaining in each medicine container and

wherein the operator interface panel and the control unit are configured to permit the inputting of the desired delivery time and frequency of medicine in the medicine containers.

46. The drug delivery and monitoring system for a ventilator according to claim 45, further comprising a release sensor that communicates with said medicine containers and signals termination of actuation of said medicine container.

47. The drug delivery and monitoring system for a ventilator according to claim 45, further comprising a gas flow resistance sensor that determines the pressure and volume of gas flow through said gas conduit, wherein the control unit is programmed to increase a dosage frequency to a patient when a higher pressure and/or relatively short cycle time on reversal of gas flow is detected.

48. The drug delivery and monitoring system for a ventilator according to claim 45, further comprising a gas flow resistance sensor that determines the pressure and volume of gas flow through said gas conduit, wherein said control unit modifies an interval of actuation of a medicine container of said plurality of medicine containers in response to a change in gas pressure in said gas conduit.

49. The drug delivery and monitoring system for a ventilator according to claim 45, further comprising an agitator that agitates a medicine container of said plurality of medicine containers prior to actuation of said medicine container to dispense medicine into said gas conduit.

50. The drug delivery and monitoring system for a ventilator according to claim 45, wherein said plurality of medicine containers engage a manifold, and wherein said manifold rotates.

51. The drug delivery and monitoring system for a ventilator according to claim 50, wherein rotation of said manifold is controlled by said control unit to rotate said manifold at defined intervals, wherein the medicine containers, actuator and manifold are contained in a housing provided with a lock.

52. The drug delivery and monitoring system for a ventilator according to claim 45, wherein said control unit counts dosages dispensed from each of said plurality of medicine containers.

53. The drug delivery and monitoring system for a ventilator according to claim 45, wherein said control unit is connected by a cable to said actuator and said control unit is positioned remotely from said gas conduit, said plurality of medicine containers and said actuator.

54. The drug delivery and monitoring system for a ventilator according to claim 45, wherein said control unit maintains logs of usage, medications delivered to the patient, and a drug configuration library.

55. The drug delivery and monitoring system for a ventilator according to claim 45, wherein said control unit comprises a dosage counter to provide information regarding remaining dosages for each of said plurality of medicine containers, and information regarding an interval between dosages for each of said medicine containers.

56. The drug delivery and monitoring system for a ventilator according to claim 45, wherein said operator interface panel comprises an input for an interval between dosages for each of said medicine containers.

57. The drug delivery and monitoring system for a ventilator according to claim 45, wherein said plurality of medicine containers engage an index table, and wherein said index table rotates at defined intervals as signaled by said control unit.

58. The drug delivery and monitoring system for a ventilator according to any one of claims 45-57 wherein the system further comprises a spectrometer, disposed in the conduit, to analyze patient effluent gases.

59. The drug delivery and monitoring system for a ventilator according to any one of claims 45-58 wherein the medicine containers are metered dose inhalers.

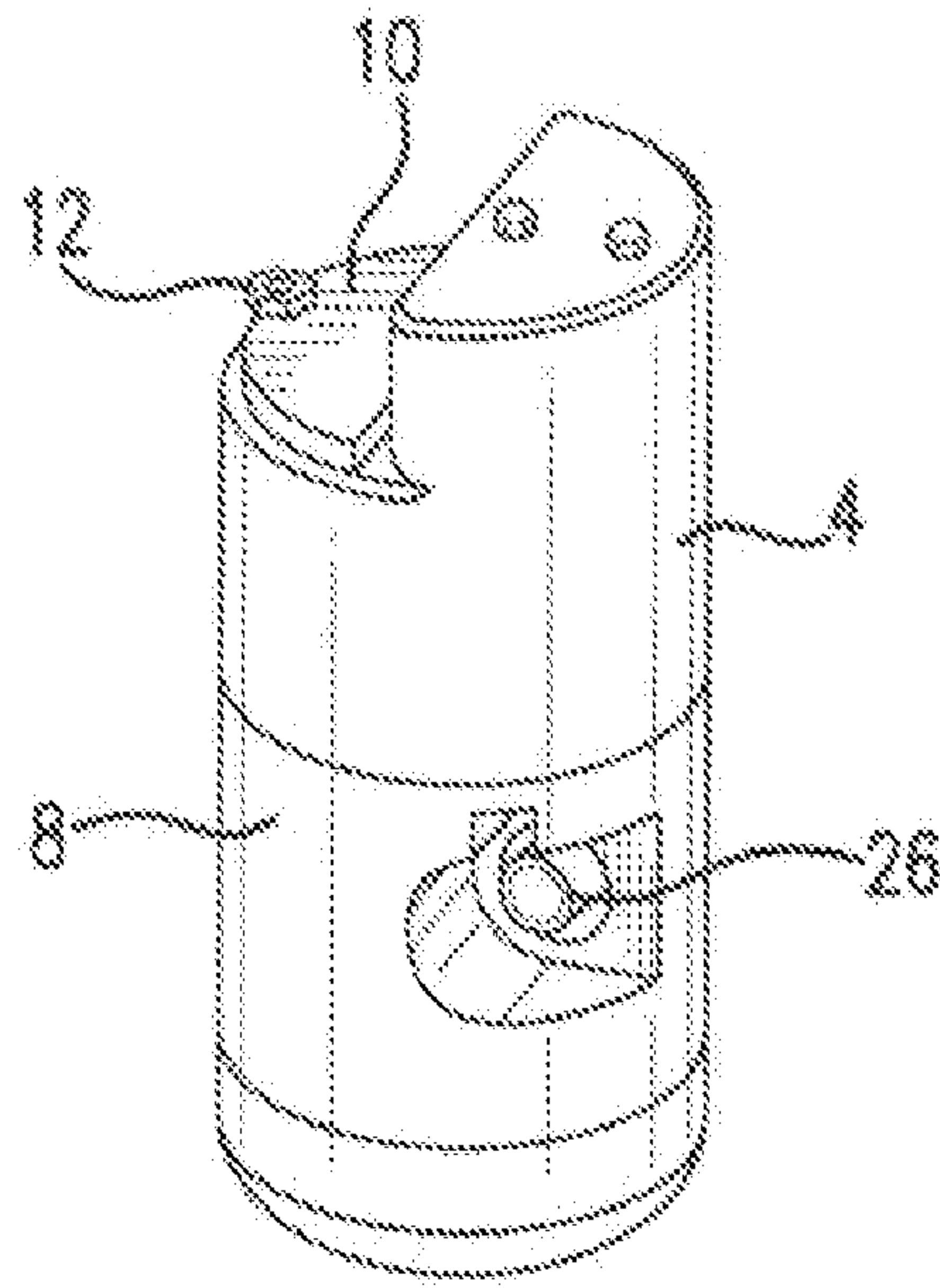
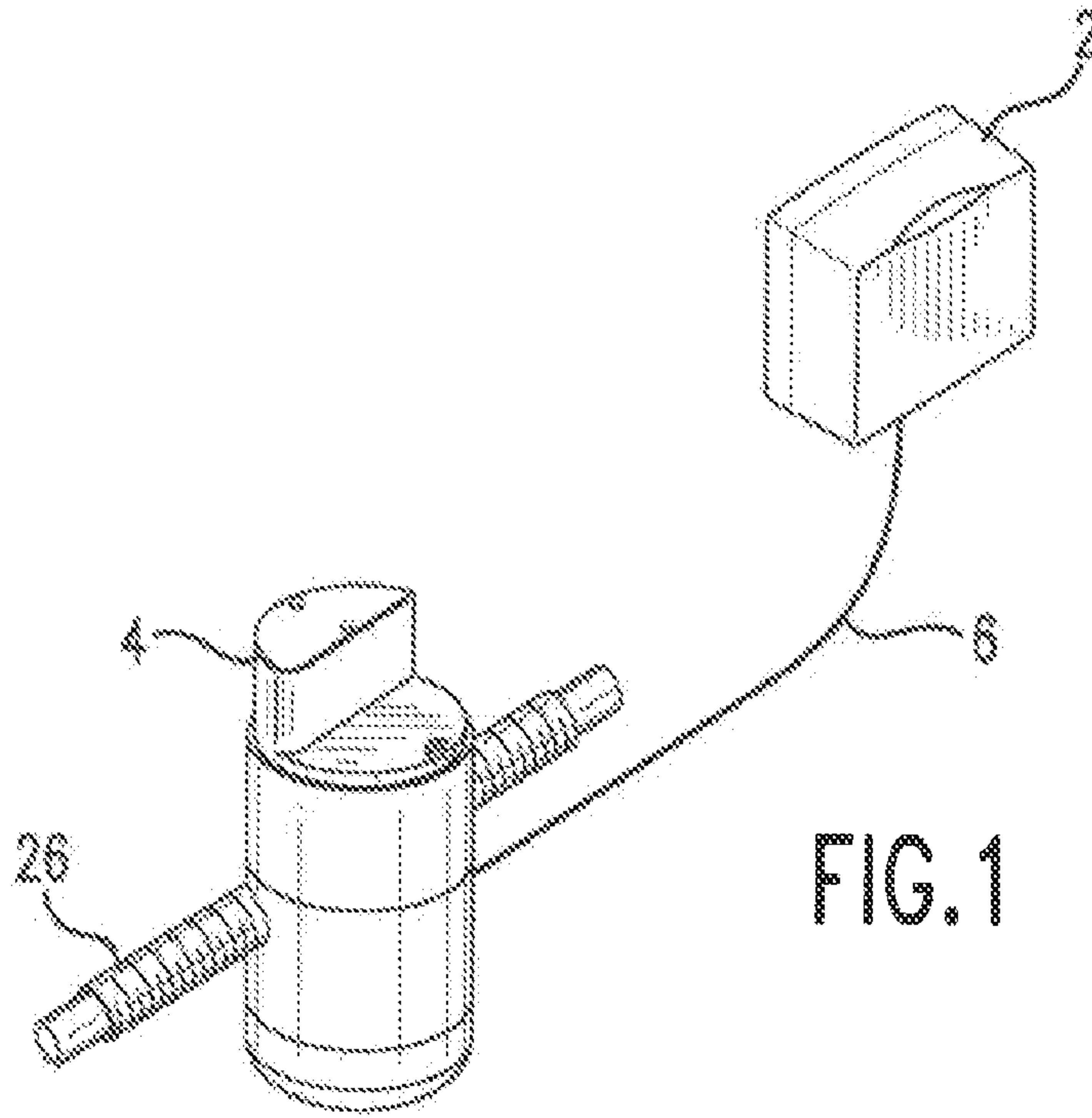

FIG. 2

2/5

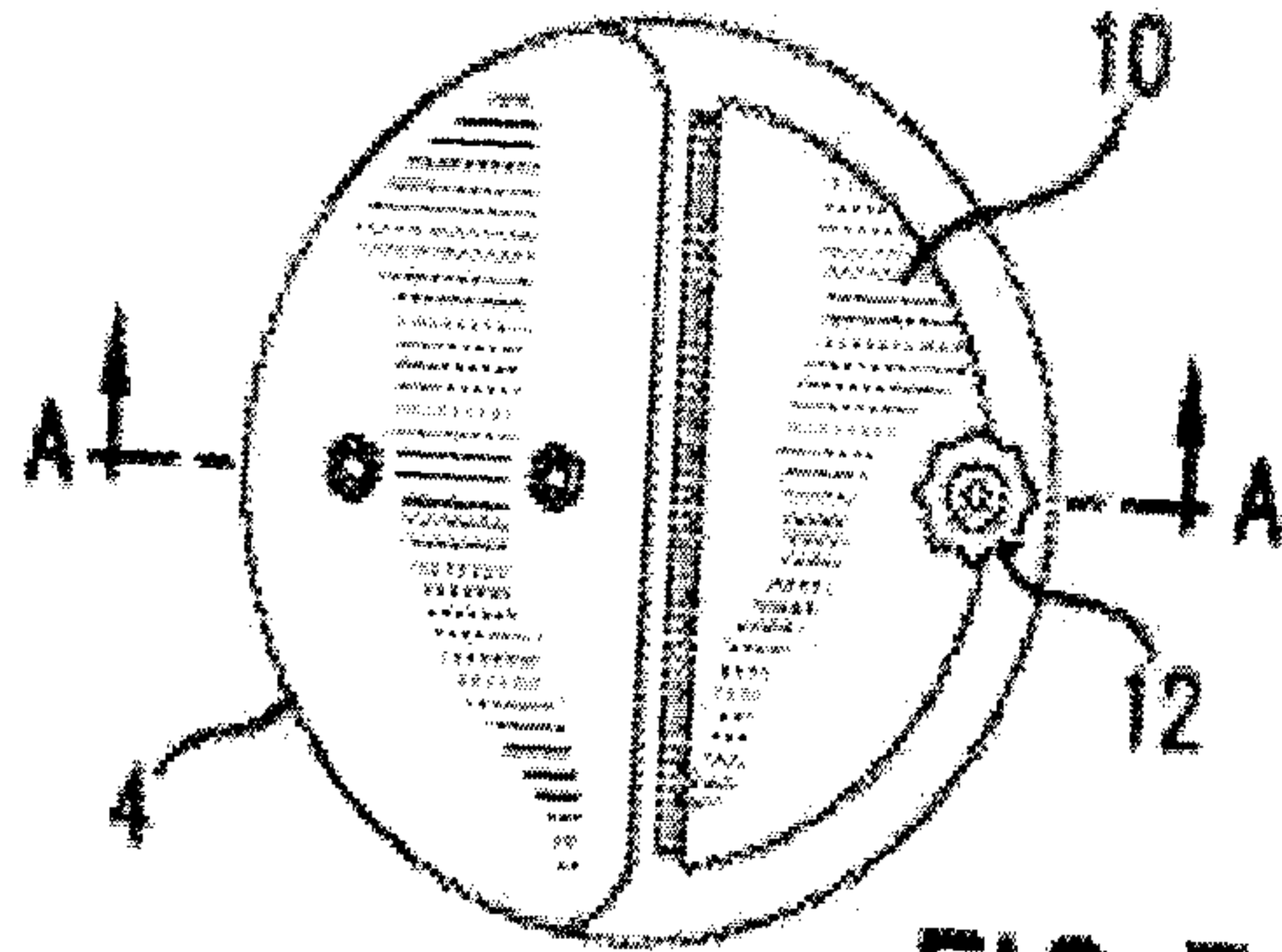

FIG. 3

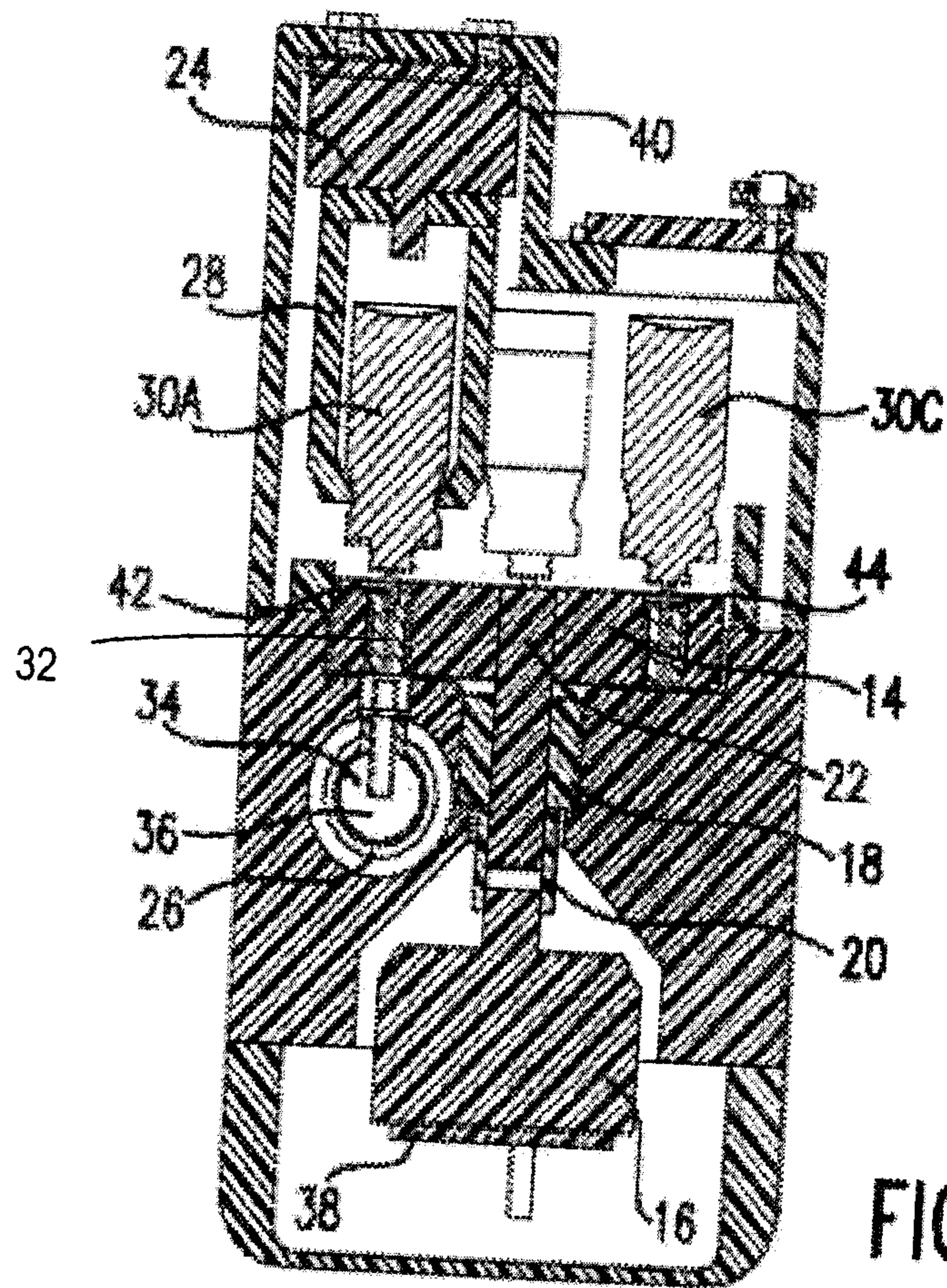

FIG. 4

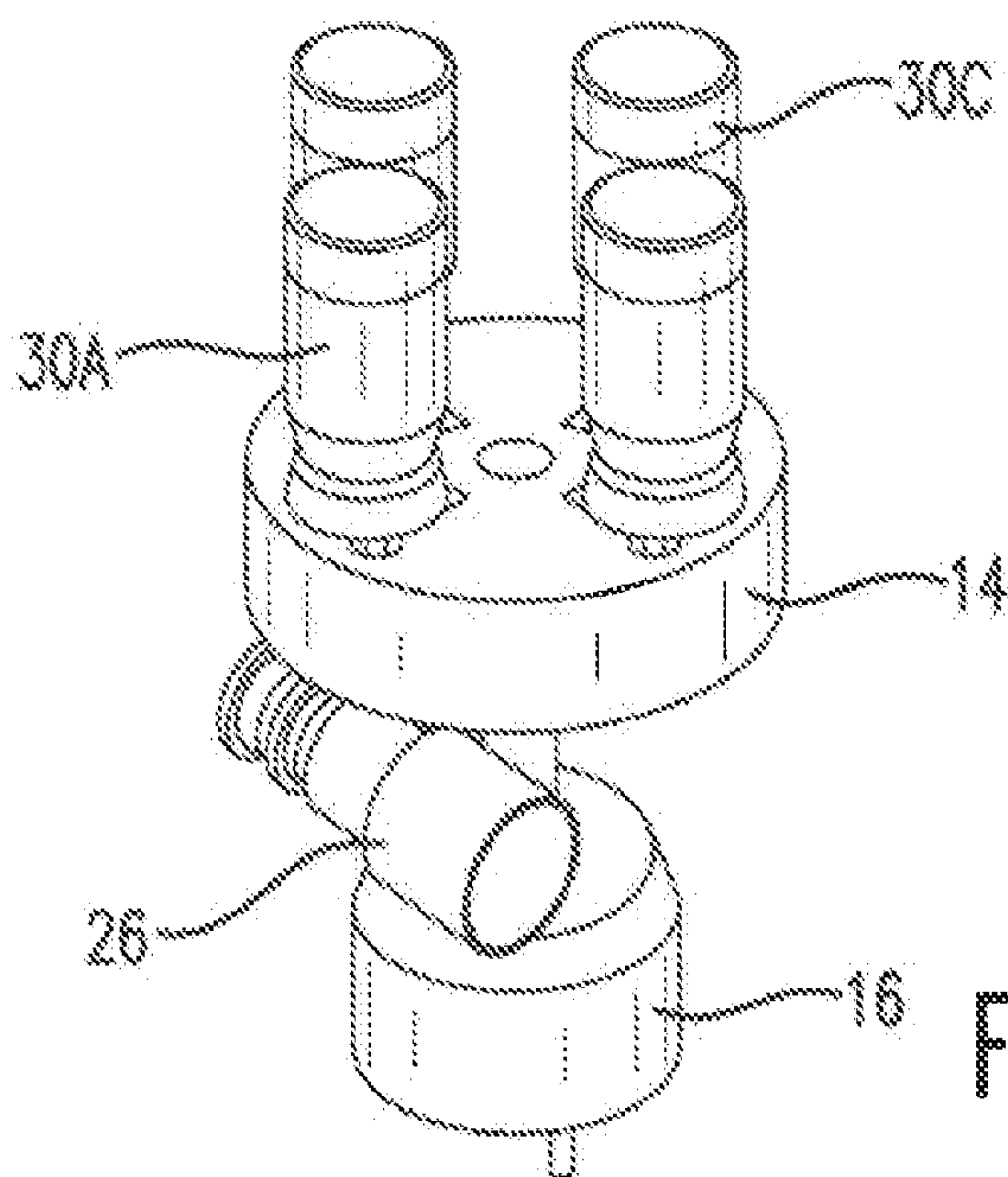
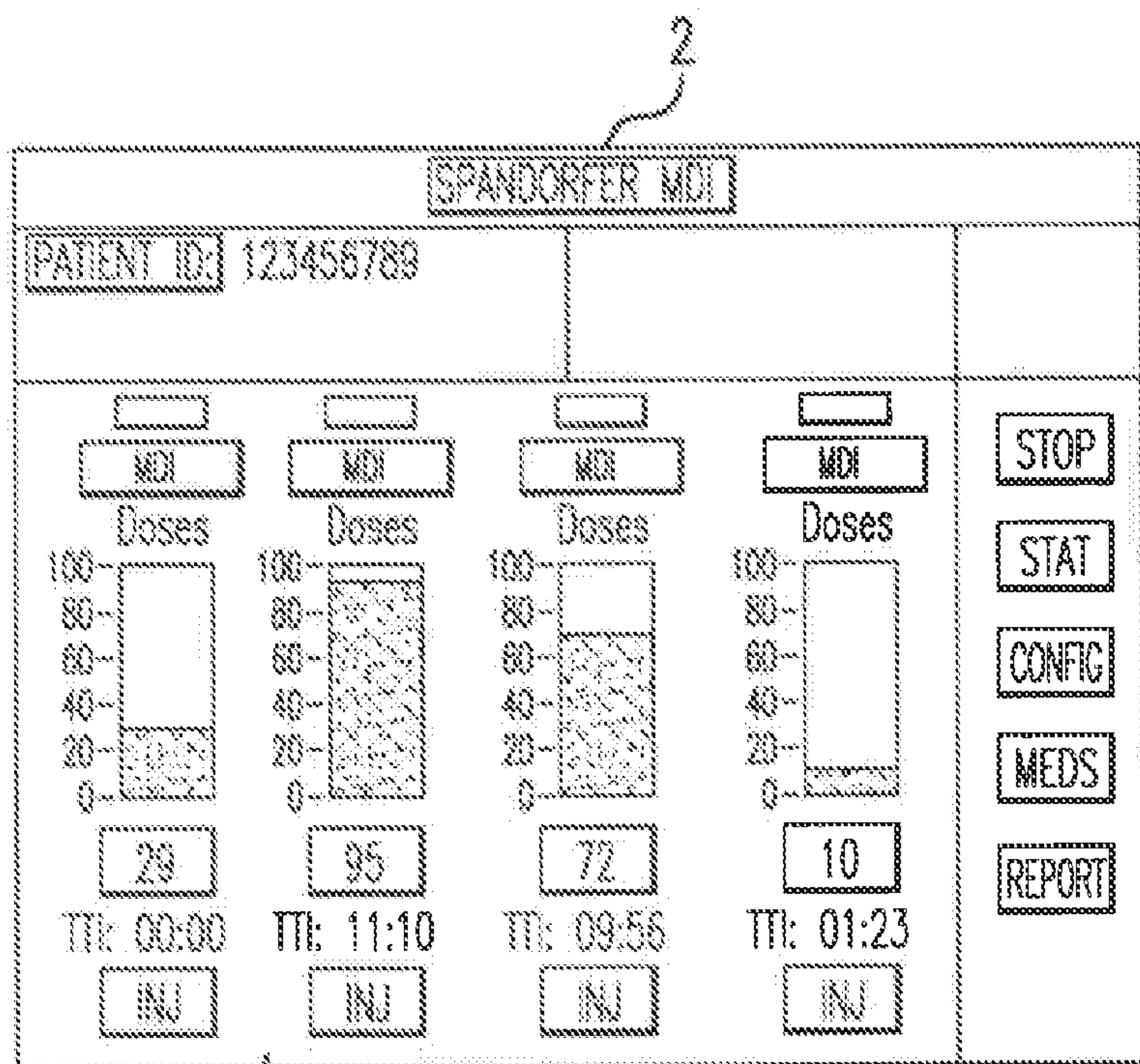

FIG. 5



50

FIG. 6

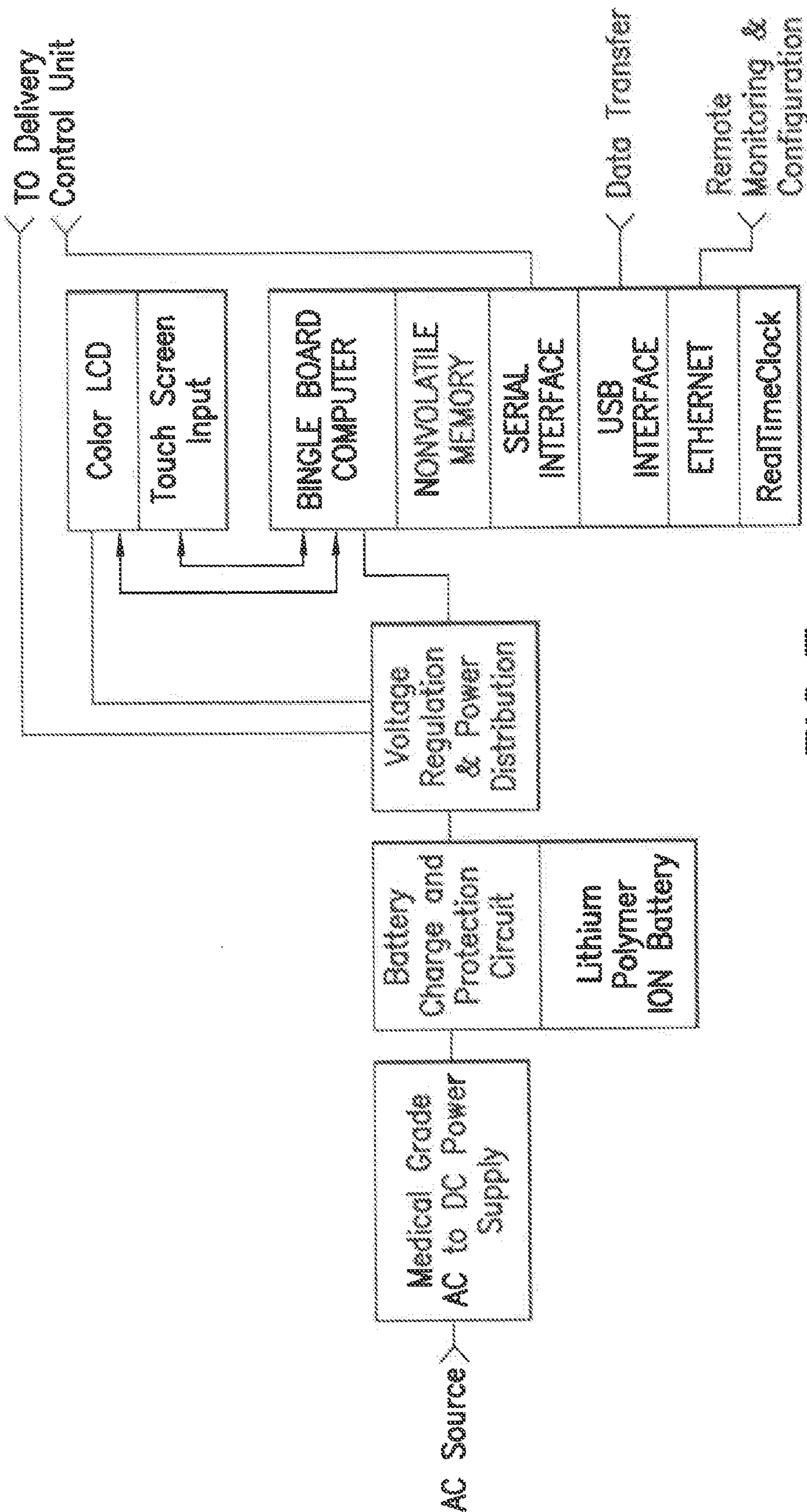

FIG. 7

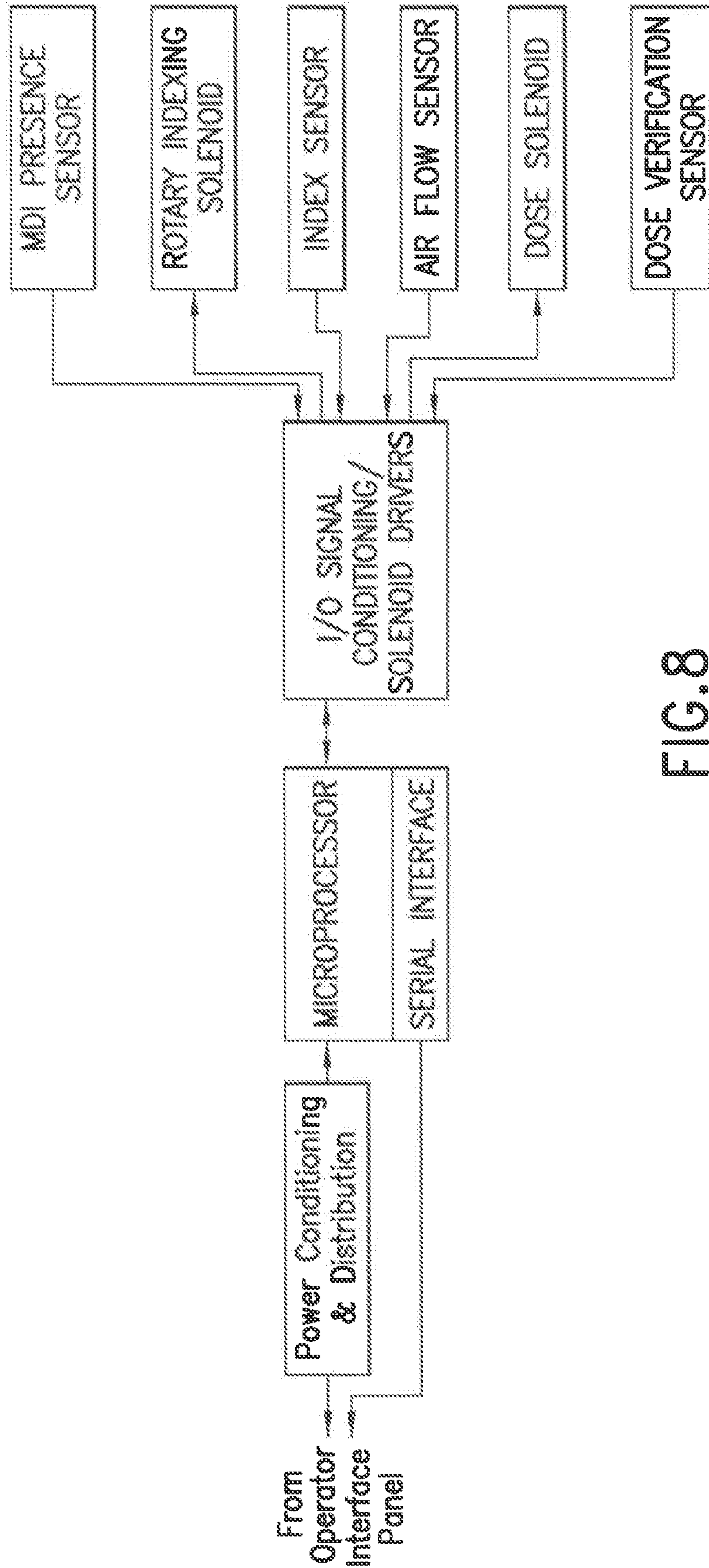

FIG. 8

