

(12) STANDARD PATENT
(19) AUSTRALIAN PATENT OFFICE

(11) Application No. **AU 2017227162 B2**

(54) Title
Heat exchanger and air conditioner

(51) International Patent Classification(s)
F28F 9/02 (2006.01) **F28F 9/22** (2006.01)
F25B 39/00 (2006.01)

(21) Application No: **2017227162** (22) Date of Filing: **2017.02.17**

(87) WIPO No: **WO17/150221**

(30) Priority Data

(31) Number	(32) Date	(33) Country
2016-038405	2016.02.29	JP

(43) Publication Date: **2017.09.08**

(44) Accepted Journal Date: **2019.06.20**

(71) Applicant(s)
Mitsubishi Heavy Industries Thermal Systems, Ltd.

(72) Inventor(s)
Katsurayama, Yohei;Aoki, Yasutaka;Tatenoi, Hideaki;Sakai, Masayuki

(74) Agent / Attorney
Phillips Ormonde Fitzpatrick, PO Box 323, Collins Street West, VIC, 8007, AU

(56) Related Art
WO 2012098917 A1
US 20100206535 A1

(12) 特許協力条約に基づいて公開された国際出願

(19) 世界知的所有権機関
国際事務局

(43) 国際公開日
2017年9月8日(08.09.2017)



(10) 国際公開番号
WO 2017/150221 A1

- (51) 国際特許分類:
F28F 9/02 (2006.01) F28F 9/22 (2006.01)
F25B 39/00 (2006.01)
 - (21) 国際出願番号: PCT/JP2017/005960
 - (22) 国際出願日: 2017年2月17日(17.02.2017)
 - (25) 国際出願の言語: 日本語
 - (26) 国際公開の言語: 日本語
 - (30) 優先権データ:
特願 2016-038405 2016年2月29日(29.02.2016) JP
 - (71) 出願人: 三菱重工サーマルシステムズ株式会社
(MITSUBISHI HEAVY INDUSTRIES THERMAL SYSTEMS, LTD.) [JP/JP]; 〒1088215 東京都港区港南二丁目16番5号 Tokyo (JP).
 - (72) 発明者: 葛山 洋平(KATSURAYAMA Yohei); 〒1088215 東京都港区港南二丁目16番5号 三菱重工工業株式会社内 Tokyo (JP). 青木 泰高(AOKI Yasutaka); 〒1088215 東京都港区港南二丁目16番5号 三菱重工工業株式会社内 Tokyo (JP). 立野井 秀哲(TATENOI Hideaki); 〒1088215 東京都港区港南二丁目16番5号 三菱重工工業株式会社内 Tokyo (JP). 左海 将之(SAKAI Masayuki); 〒1088215 東京都港区港南二丁目16番5号 三菱重工工業株式会社内 Tokyo (JP).
 - (74) 代理人: 森 隆一郎, 外(MORI Ryuichirou et al.); 〒1006620 東京都千代田区丸の内一丁目9番2号 Tokyo (JP).
 - (81) 指定国 (表示のない限り、全ての種類の国内保護が可能): AE, AG, AL, AM, AO, AT, AU, AZ, BA, BB, BG, BH, BN, BR, BW, BY, BZ, CA, CH, CL, CN, CO, CR, CU, CZ, DE, DJ, DK, DM, DO, DZ, EC, EE, EG, ES, FI, GB, GD, GE, GH, GM, GT, HN, HR, HU, ID, IL, IN, IR, IS, KE, KG, KH, KN, KP, KR, KW, KZ, LA, LC, LK, LR, LS, LU, LY, MA, MD, ME, MG, MK, MN, MW, MX, MY, MZ, NA, NG, NI, NO, NZ, OM, PA, PE, PG, PH, PL, PT, QA, RO, RS, RU, RW, SA, SC, SD, SE, SG, SK, SL, SM, ST, SV, SY, TH, TJ, TM, TN, TR, TT, TZ, UA, UG, US, UZ, VC, VN, ZA, ZM, ZW.
 - (84) 指定国 (表示のない限り、全ての種類の広域保護が可能): ARIPO (BW, GH, GM, KE, LR, LS, MW, MZ, NA, RW, SD, SL, ST, SZ, TZ, UG, ZM, ZW), ユーロパ (AM, AZ, BY, KG, KZ, RU, TJ, TM), ヨーロッパ (AL, AT, BE, BG, CH, CY, CZ, DE, DK, EE, ES, FI, FR, GB, GR, HR, HU, IE, IS, IT, LT, LU, LV, MC, MK, MT, NL, NO, PL, PT, RO, RS, SE, SI, SK, SM, TR), OAPI (BF, BJ, CF, CG, CI, CM, GA, GN, GQ, GW, KM, ML, MR, NE, SN, TD, TG).
- 添付公開書類:
— 国際調査報告 (条約第 21 条(3))

(54) Title: HEAT EXCHANGER AND AIR CONDITIONER

(54) 発明の名称: 熱交換器及び空気調和機

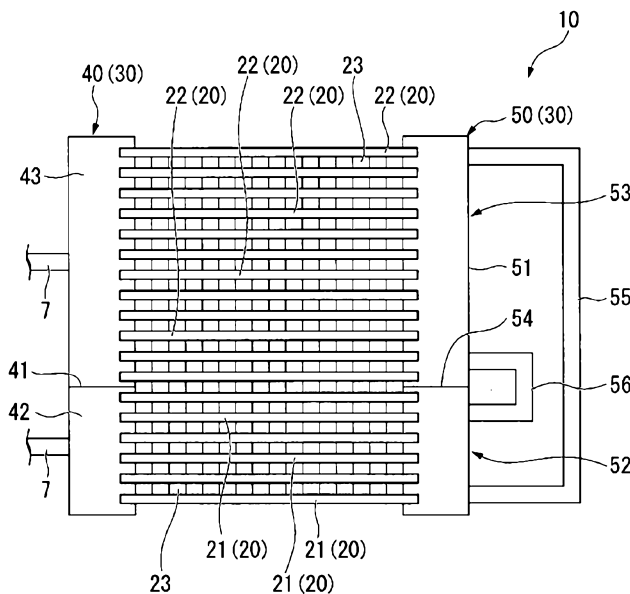

(57) Abstract: A heat exchanger (10) is provided with: a plurality of first heat transfer tubes (21); a first header section (52); a plurality of second heat transfer tubes (22); a second header section (53); a first connecting tube (55); and a second connecting tube (56). The plurality of first heat transfer tubes (21) extend in the horizontal direction and are arranged with gaps therebetween in the vertical direction. One end of each of the plurality of first heat transfer tubes (21) is connected to the first header section (52) in a communicating state. The plurality of second heat transfer tubes (22) extend in the horizontal direction and are arranged with gaps therebetween in the vertical direction. One end of each of the plurality of second heat transfer tubes (22) is connected to the second header section (53) in a communicating state. The first connecting tube (55) connects a lower portion of the first header section (52) and an upper portion of the second header section (53). The second connecting tube (56) connects an upper portion of the first header section (52) and a lower portion of the second header section (53).

(57) 要約:

[続葉有]

WO 2017/150221 A1



熱交換器（１０）は、複数の第一伝熱管（２１）と第一ヘッダ部（５２）と複数の第二伝熱管（２２）と第二ヘッダ部（５３）と第一接続管（５５）と第二接続管（５６）とを備える。複数の第一伝熱管（２１）は、水平方向に延び、互いに上下方向に間隔をあけて配列されている。第一ヘッダ部（５２）には、複数の第一伝熱管（２１）の一端が連通状態で接続されている。複数の第二伝熱管（２２）は、水平方向に延び、互いに上下方向に間隔をあけて配列されている。第二ヘッダ部（５３）には、複数の第二伝熱管（２２）の一端が連通状態で接続されている。第一接続管（５５）は、第一ヘッダ部（５２）の下部と第二ヘッダ部（５３）の上部とを接続する。第二接続管（５６）は、第一ヘッダ部（５２）の上部と第二ヘッダ部（５３）の下部とを接続する。

DESCRIPTION

Title of Invention

HEAT EXCHANGER AND AIR CONDITIONER

Technical Field

[0001]

The present invention relates to a heat exchanger and an air conditioner.

This application claims priority based on Japanese Patent Application No. 2016-038405 filed on February 29, 2016; the contents of which are incorporated herein by reference.

Background Art

[0002]

A heat exchanger of an air conditioner, which includes a plurality of heat transfer tubes extending in a horizontal direction, is known. The plurality of heat transfer tubes are disposed at intervals in a vertical direction. A fin is provided on an outer surface of each heat transfer tube. Both ends of the plurality of heat transfer tubes are connected to a pair of headers extending in the vertical direction, respectively. Such a heat exchanger is configured such that a refrigerant, which is introduced into a first header out of a pair of headers and is circulated

in a second header via the heat transfer tubes, turns back at the second header to return to the first header again via the heat transfer tubes, in order to secure a flow passage length for the refrigerant.

[0003]

The inside of the second header, which is the header at a turnback side, is partitioned into a plurality of regions with a partition plate partitioning the inside of the header in the vertical direction. Accordingly, a refrigerant introduced in one region of the header via the heat transfer tubes returns to the first header on an entrance side via the plurality of heat transfer tubes connected to the other region after being introduced into the other region of the header via a connecting tube.

For example, a heat exchanger having the connecting tube connected to a lower portion of each region of a header, into which a refrigerant that has turned back is introduced, is disclosed in PTL 1.

Citation List

Patent Literature

[0004]

[PTL 1] Japanese Patent No. 5071597

Summary of Invention

Technical Problem

[0005]

However, in a case where the heat exchanger is used as an evaporator, not the entire refrigerant introduced into one region of the header via heat transfer tubes evaporates, and the refrigerant is in a state of a gas-liquid two phase refrigerant, in which a liquid phase refrigerant and a gas phase refrigerant are mixed. In a case where such a gas-liquid two phase refrigerant is introduced in a lower portion of the other region of the header via the connecting tube, a liquid phase refrigerant with a high density is unlikely to reach upper heat transfer tubes. For this reason, a refrigerant flowing in the upper heat transfer tubes is a liquid phase refrigerant having a lower flow rate. As a consequence, there is a problem that the heat exchanger does not show a desired performance.

[0006]

With such problems in mind, at least some embodiments of the invention provide a heat exchanger which can suppress a performance decrease and an air conditioner in which the heat exchanger is used.

[0006a]

Any reference herein to a patent document or other matter which is given as prior art is not to be taken as an admission that that document or matter was known or that the information it contains was part of the common general knowledge as at the priority date of any of the claims.

Throughout the description and claims of the specification, the word "comprise" and variations of the word, such as "comprising" and "comprises", is not intended to exclude other additives, components, integers or steps.

Summary

[0007]

In view of the foregoing, the invention adopts the following means.

According to a first aspect of the invention, there is provided a heat exchanger including a plurality of first

heat transfer tubes that extend in a horizontal direction to allow a refrigerant to circulate therein, and are arranged at intervals in a vertical direction, a first header section that has a cylindrical shape extending in the vertical direction and is connected to one end of each of the plurality of first heat transfer tubes in a communicating state, a plurality of second heat transfer tubes that extend in the horizontal direction to allow the refrigerant to circulate therein, and are arranged at intervals in the vertical direction, a second header section that is connected to one end of each of the plurality of second heat transfer tubes in a communicating state, a first connecting tube that connects a lower portion of the first header section and an upper portion of the second header section together, and a second connecting tube that connects an upper portion of the first header section and a lower portion of the second header section together.

[0008]

In such a heat exchanger, for example, a refrigerant with a high liquid phase content and a high density, out of gas-liquid two phase refrigerants introduced in the first header section via the first heat transfer tubes, is introduced into the first connecting tube connected to the lower portion of the first header section. For this reason, the refrigerant with a high density is supplied to the upper

portion of the second header section via the first connecting tube. On the other hand, a refrigerant with a high gas phase content and a low density, out of gas-liquid two phase refrigerants introduced in the first header section, is introduced into the second connecting tube connected to the upper portion of the first header section. For this reason, the refrigerant with a low density is supplied to the lower portion of the second header section via the second connecting tube.

Consequently, in the second header section, the refrigerant with a high liquid phase content pours down from the upper portion and the refrigerant with a high gas phase content is blown upwards from the lower portion. For this reason, the liquid phase content and the gas phase content are caused to be mixed, and a refrigerant density over the entire area in the second header section in the vertical direction is homogenized. Thus, the uniformization of distributions of refrigerants supplied to the plurality of heat transfer tubes connected to the second header section can be achieved.

[0009]

The heat exchanger may further include a second header partition plate that partitions a space in the second header section into a second upper region communicating with the first connecting tube and a second lower region

communicating with the second connecting tube and has a communication-hole formed vertically therethrough.

[0010]

Consequently, a refrigerant with a high liquid phase content introduced from the upper portion of the second header section temporarily stays in the second upper region. On the other hand, a refrigerant with a high gas phase content introduced from the lower portion of the second header section is blown upwards to the second upper region via the communication-hole. Accordingly, in the upper portion of the second header section, a gas phase content does not become excessive. That is, the mixing of a gas phase content and a liquid phase content can be caused.

[0011]

The heat exchanger may further include a first header partition plate that partitions a space in the first header section into a first lower region communicating with the first connecting tube and a first upper region communicating with the second connecting tube.

[0012]

A liquid-gas ratio of a refrigerant introduced into the first header section via the first heat transfer tubes is different for each of the first heat transfer tubes. In particular, a refrigerant introduced from the first heat transfer tubes positioned on the upper side into the first

header section has a higher gas phase content, and a refrigerant introduced from the first heat transfer tubes positioned on the lower side into the first header section has a higher liquid phase content. For this reason, since the first header partition plate partitions the first header section into the first lower region and the second upper region, the gas phase-liquid phase ratios of refrigerants supplied to the lower portion and the upper portion of the second header section via the first connecting tube and the second connecting tube can be stabilized. In addition, the gas-liquid ratios or flow rates of refrigerants supplied to the lower portion and the upper portion of the second header section can be adjusted so as to be desired values by adjusting the vertical position of the first header partition plate.

[0013]

In the heat exchanger, at least one of the first connecting tube and the second connecting tube may have a flat tubular shape in which a plurality of flow passages are arranged at intervals.

[0014]

Accordingly, a large amount of refrigerants circulating inside can be secured and a pressure loss of a refrigerant can be reduced, compared to, for example, the first connecting tube and the second connecting tube having

circular sections.

[0015]

In the heat exchanger, a header is further included, the header may have a header body, which has a cylindrical shape extending in the vertical direction, and a main partition plate which partitions an inside of the header body into upper and lower parts, the first header section may be a portion below the main partition plate in the header body, and the second header section may be a portion above the main partition plate in the header body.

[0016]

The heat exchanger having the first header section and the second header section can be easily configured by forming the first header section and the second header section with the main partition plate in one header.

In addition, oil separated out from a refrigerant is led to the first header section via the second connecting tube without being stored in the second header section. Consequently, the oil can be mixed again in the refrigerant. Therefore, it is possible to suppress the insufficiency of oil in the refrigerant.

[0017]

According to a second aspect of the invention, there is provided an air conditioner including any one of the heat exchangers described above.

[0018]

Accordingly, a decrease in a heat exchange performance caused by inhomogeneous distribution of the refrigerant is suppressed, and thus the air conditioner with a high efficiency can be provided.

Advantageous Effects of Invention

[0019]

The heat exchanger and the air conditioner according to one aspect of the invention can achieve the suppression of an efficiency decrease.

Brief Description of Drawings

[0020]

Fig. 1 is an overall configuration view of an air conditioner according to a first embodiment of the invention.

Fig. 2 is a longitudinal sectional view of a heat exchanger according to the first embodiment of the invention.

Fig. 3 is a perspective view of the heat exchanger according to the first embodiment of the invention.

Fig. 4 is a view for illustrating an operational effect in a case where the heat exchanger according to the first embodiment of the invention is used as an evaporator.

Fig. 5 is a view for illustrating an operational effect in a case where the heat exchanger according to the first embodiment of the invention is used as a condenser.

Fig. 6 is a perspective view of a heat exchanger

according to a second embodiment of the invention.

Fig. 7 is a longitudinal sectional view of the heat exchanger according to the second embodiment of the invention.

Fig. 8 is a perspective view of a heat exchanger according to a third embodiment of the invention.

Fig. 9 is a view for illustrating an operational effect in a case where the heat exchanger according to the third embodiment of the invention is used as an evaporator.

Fig. 10 is a view for illustrating an operational effect in a case where the heat exchanger according to the third embodiment of the invention is used as a condenser.

Fig. 11 is a perspective view of a first connecting tube and a second connecting tube of a heat exchanger according to a fourth embodiment of the invention.

Fig. 12 is a sectional view of a heat exchanger according to a first modification example of the embodiment of the invention.

Fig. 13 is a sectional view of a heat exchanger according to a second modification example of the embodiment of the invention.

Fig. 14 is a sectional view of a heat exchanger according to a third modification example of the embodiment of the invention.

Fig. 15 is a sectional view of a heat exchanger

according to a fourth modification example of the embodiment of the invention.

Description of Embodiments

[0021]

Hereinafter, an air conditioner including a heat exchanger according to a first embodiment of the invention will be described with reference to Figs. 1 to 5.

As illustrated in Fig. 1, an air conditioner 1 includes a compressor 2, an indoor heat exchanger 3 (heat exchanger 10), an expansion valve 4, an outdoor heat exchanger 5 (heat exchanger 10), a four-way valve 6, and a pipe 7 that connects the configuration elements together. The air conditioner 1 configures a refrigerant circuit with the elements described above.

[0022]

The compressor 2 compresses a refrigerant and supplies the compressed refrigerant to the refrigerant circuit.

The indoor heat exchanger 3 performs heat exchange between the refrigerant and indoor air. The indoor heat exchanger 3 is used as an evaporator to absorb heat from the inside during cooling operation, and is used as a condenser to radiate heat to the inside during heating operation. The outdoor heat exchanger 5 performs heat exchange between the refrigerant and outdoor air.

The expansion valve 4 reduces a pressure by expanding

the high-pressure refrigerant liquefied by the condenser exchanging heat.

The outdoor heat exchanger 5 is used as a condenser to radiate heat to the outside during cooling operation and is used as an evaporator to absorb heat from the outside during heating operation.

The four-way valve 6 switches between directions where a refrigerant circulates during heating operation and during cooling operation. Consequently, a refrigerant circulates in the compressor 2, the outdoor heat exchanger 5, the expansion valve 4, and the indoor heat exchanger 3 in this order during cooling operation. On the other hand, a refrigerant circulates in the compressor 2, the indoor heat exchanger 3, the expansion valve 4, and the outdoor heat exchanger 5 in this order during heating operation.

[0023]

Next, the heat exchangers 10 which are used as the indoor heat exchanger 3 and the outdoor heat exchanger 5 will be described with reference to Figs. 2 to 5.

The heat exchangers 10 each include a plurality of heat transfer tubes 20, a plurality of fins 23, a pair of headers 30, a first connecting tube 55, and a second connecting tube 56.

[0024]

The heat transfer tubes 20 are tubular members

linearly extending in a horizontal direction, and flow passages through which a refrigerant circulates are formed therein. The plurality of heat transfer tubes 20 are arranged at intervals in a vertical direction, and are disposed so as to be parallel to each other.

In the embodiment, the heat transfer tubes 20 each have a flat tubular shape, and the plurality of flow passages arranged in the horizontal direction orthogonal to an extending direction of the heat transfer tubes 20 are formed inside the heat transfer tubes 20. The plurality of flow passages are arranged so as to be parallel to each other. Consequently, a sectional shape orthogonal to the extending direction of the heat transfer tubes 20 is a flat shape of which a longitudinal direction is the horizontal direction orthogonal to the extending direction of the heat transfer tubes 20.

[0025]

The fins 23 each are disposed between the heat transfer tubes 20 arranged as described above. The fins 23 of the embodiment extend in a so-called corrugated shape so as to be alternately in contact with the vertically nearby heat transfer tubes 20 as facing the extending direction of each of the heat transfer tubes 20. Without being limited thereto, the shapes of the fins 23 may be any shape insofar as the fins are provided so as to protrude from outer

peripheral surfaces of the heat transfer tubes 20.

[0026]

At both ends of the plurality of heat transfer tubes 20, the pair of headers 30 is provided such that the heat transfer tubes 20 are sandwiched therebetween from the extending direction of the heat transfer tubes 20. One header of the pair of headers 30 is an entrance side header 40, which is an entrance for a refrigerant from the outside to the heat exchanger 10. In addition, the other header is a turnback side header 50 for a refrigerant to turn back in the heat exchanger 10.

[0027]

The entrance side header 40 is a cylindrical member extending in the vertical direction, and an upper end and a lower end of the entrance side header are closed. The entrance side header 40 is partitioned into two upper and lower regions with a partition plate 41. In the entrance side header 40, the lower region partitioned with the partition plate 41 is set as a lower entry region 42 and the upper region is set as an upper entry region 43. The lower entry region 42 and the upper entry region 43 are in a state of not communicating with each other in the entrance side header 40. The lower entry region 42 and the upper entry region 43 each are connected to the pipe 7 configuring the refrigerant circuit.

Herein, out of the plurality of heat transfer tubes 20 connected to the entrance side header 40, the heat transfer tubes 20 connected to the lower entry region 42 in a communicating state are set as first heat transfer tubes 21, and the heat transfer tubes 20 connected to the upper entry region 43 in a communicating state are set as second heat transfer tubes 22.

[0028]

The turnback side header 50 includes a header body 51 and a main partition plate 54.

The header body 51 is a cylindrical member extending in the vertical direction, and an upper end and a lower end of the header body are closed. The main partition plate 54 is provided in the header body 51, and partitions a space in the header body 51 into two upper and lower regions. A portion below the main partition plate 54 of the header body 51 is set as a first header section 52, and a portion above the main partition plate 54 of the header body 51 is set as a second header section 53. That is, in the embodiment, the first header section 52 and the second header section 53 each of which has a space therein are formed in the turnback side header 50 by the inside of the header body 51 being partitioned with the main partition plate 54. In other words, the turnback side header 50 is configured with the first header section 52 and the second header section

53.

[0029]

The first heat transfer tubes 21 each are connected to the first header section 52 so as to be in a communicating state with the inside of the first header section 52. The second heat transfer tubes 22 each are connected to the second header section 53 so as to be in a communicating state with the second header section 53. In other words, the heat transfer tubes 20 connected to the first header section 52 are set as the first heat transfer tubes 21, and the heat transfer tubes 20 connected to the second header section 53 are set as the second heat transfer tubes 22. The second heat transfer tubes 22 are provided more than the first heat transfer tubes 21 in the embodiment. Without being limited thereto, however, the first heat transfer tubes 21 may be provided more than the second heat transfer tubes 22. In addition, the same number of the first heat transfer tubes 21 and the second heat transfer tubes 22 may be provided.

[0030]

The first connecting tube 55 is a tubular member in which a flow passage is formed. One end of the first connecting tube is connected to the first header section 52 in a communicating state with the inside of the first header section 52, and the other end is connected to the second

header section 53 in a communicating state with the inside of the second header section 53. More specifically, one end of the first connecting tube 55 is connected to a lower portion of the first header section 52. On the other hand, the other end of the first connecting tube 55 is connected to an upper portion of the second header section 53.

[0031]

Herein, it is preferable that one end of the first connecting tube 55 be connected to the first header section 52 at a position (position where at least a part of the first connecting tube overlaps when seen from the horizontal direction) where at least a part of the first connecting tube overlaps a connection point of the first heat transfer tube 21, which is positioned the lowermost, out of the plurality of first heat transfer tubes 21 connected to the first header section 52, to the first header section 52 in the vertical direction.

In addition, it is preferable that the other end of the first connecting tube 55 be connected to the second header section 53 at a position (position where at least a part of the first connecting tube overlaps when seen from the horizontal direction) where at least a part of the first connecting tube overlaps a connection point of the second heat transfer tube 22, which is positioned the uppermost, out of the plurality of second heat transfer tubes 22

connected to the second header section 53, to the second header section 53 in the vertical direction.

[0032]

The second connecting tube 56 is a tubular member in which a flow passage is formed. As the first connecting tube 55, one end of the second connecting tube is connected to the first header section 52 in a communicating state with the inside of the first header section 52, and the other end is connected to the second header section 53 in a communicating state with the inside of the second header section 53. On the other hand, unlike the first connecting tube 55, one end of the second connecting tube 56 is connected to an upper portion of the first header section 52 and the other end is connected to a lower portion of the second header section 53.

[0033]

It is sufficient that one end of the second connecting tube 56 is connected to the first header section 52 higher than one end of the first connecting tube 55 is connected. In addition, it is sufficient that the other end of the second connecting tube 56 is connected to the second header section 53 lower than the other end of the first connecting tube 55 is connected.

[0034]

It is preferable that one end of the second connecting

tube 56 be connected to the first header section 52 at a position (position where at least a part of the second connecting tube overlaps when seen from the horizontal direction) where at least a part of the second connecting tube overlaps a connection point of the first heat transfer tube 21, which is positioned the uppermost, out of the plurality of first heat transfer tubes 21 connected to the first header section 52, to the first header section 52 in the vertical direction.

In addition, it is preferable that the other end of the second connecting tube 56 be connected to the second header section 53 at a position (position where at least a part of the second connecting tube overlaps when seen from the horizontal direction) where at least a part of the second connecting tube overlaps a connection point of the second heat transfer tube 22, which is positioned the lowermost, out of the plurality of second heat transfer tubes 22 connected to the second header section 53, to the second header section 53 in the vertical direction.

[0035]

Next, operation and effects in a case where the heat exchanger 10 is used as an evaporator will be described.

In a case where the heat exchanger 10 is the indoor heat exchanger 3, the air conditioner 1 is used as an evaporator during cooling operation, and in a case where

the heat exchanger is the outdoor heat exchanger 5, the air conditioner 1 is used as an evaporator during heating operation.

[0036]

When the heat exchanger 10 is used as an evaporator, a liquid phase refrigerant is supplied from the pipe 7 to the lower entry region 42 of the entrance side header 40 illustrated in Fig. 2. The refrigerant is divided and supplied to the plurality of first heat transfer tubes 21 in the lower entry region 42, and exchanges heat with the external atmosphere of the first heat transfer tubes 21 in the process of circulating in the first heat transfer tubes 21, thereby causing evaporation. Consequently, the refrigerant supplied from the first heat transfer tubes 21 into the first header section 52 of the turnback side header 50 becomes a gas-liquid two phase refrigerant, in which a liquid phase and a gas phase are mixed, by some of the refrigerant changing from the liquid phase to the gas phase.

[0037]

As illustrated in Fig. 4, out of the gas-liquid two phase refrigerant supplied into the first header section 52, a refrigerant with a high liquid phase content and a high density gathers at the lower portion of the first header section 52 due to gravity, and a refrigerant with a high gas phase content and a low density gathers at the upper

portion of the first header section 52. As a consequence, the refrigerant with a high liquid phase content is introduced into the first connecting tube 55 connected to the lower portion of the first header section 52, and is introduced into the second header section 53 via the first connecting tube 55. On the other hand, the refrigerant with a high gas phase content is introduced into the second connecting tube 56 connected to the upper portion of the first header section 52, and is introduced into the second header section 53 via the second connecting tube 56.

[0038]

Consequently, the refrigerant with a high liquid phase content is supplied to the upper portion of the second header section 53 connected to the first connecting tube 55. In the second header section 53, the refrigerant with a high liquid phase content pours down from the upper portion to the lower portion. On the other hand, the refrigerant with a high gas phase content is supplied to the lower portion of the second header section 53 connected to the second connecting tube 56. In the second header section 53, the refrigerant with a high gas phase content is blown upwards from the lower portion. As a consequence, the refrigerant with a high gas phase content and the refrigerant with a high liquid phase content are mixed together in the second header section 53, and thus the homogenization of a gas-

liquid ratio of a refrigerant in the entire second header section 53 is achieved. Consequently, the refrigerant of which the gas-liquid ratio is homogenized is supplied to each of the plurality of second heat transfer tubes 22 connected to the second header section 53.

[0039]

Then, the refrigerant again causes evaporation by exchanging heat with the external atmosphere of the second heat transfer tubes 22 in the process of circulating in the second heat transfer tubes 22. Consequently, in the second heat transfer tubes 22, the remaining liquid phase in the refrigerant changes to the gas phase and thus the refrigerant in a gas phase state is supplied to the upper entry region 43 of the entrance side header 40. Then, the refrigerant is introduced from the upper entry region 43 to the pipe 7, thereby circulating in the refrigerant circuit.

[0040]

As described above, in the heat exchanger 10 of the embodiment, while a refrigerant with a high density, which includes a high liquid phase content, in the first header section 52 is supplied to the upper portion of the second header section 53 via the first connecting tube 55, a refrigerant with a low density, which includes a high gas phase content, in the first header section 52 is supplied to the lower portion of the second header section 53 via

the second connecting tube 56. For this reason, the positions of refrigerants with a high density and a low density are vertically inverted in the second header section 53 compared to the first header section 52. Consequently, in the second header section 53, while a refrigerant with a high density moves downwards due to gravity, a refrigerant with a low density moves upwards. Therefore, after causing refrigerants which have different densities to be mixed, the refrigerant can be led to the second heat transfer tubes 22. Thus, the uniformization of distributions of refrigerants supplied to the plurality of heat transfer tubes 20 connected to the second header section 53 can be achieved. As a consequence, the flow rate of a liquid phase refrigerant circulating in the second heat transfer tubes 22 is homogenized regardless of the vertical position of each of the second heat transfer tubes 22. Therefore, a performance decrease of the heat exchanger 10 can be suppressed.

[0041]

Next, operation and effects in a case where the heat exchanger 10 is used as a condenser will be described.

In a case where the heat exchanger 10 is the indoor heat exchanger 3, the air conditioner 1 is used as a condenser during heating operation, and in a case where the heat exchanger is the outdoor heat exchanger 5, the air

conditioner 1 is used as a condenser during cooling operation.

[0042]

When the heat exchanger 10 is used as a condenser, a gas phase refrigerant is supplied from the pipe 7 to the upper entry region 43 of the entrance side header 40 illustrated in Fig. 2. The refrigerant is divided and supplied to the plurality of second heat transfer tubes 22 in the upper entry region 43, and exchanges heat with the external atmosphere of the second heat transfer tubes 22 in the process of circulating in the second heat transfer tubes 22, thereby causing condensation. Consequently, the refrigerant supplied from the second heat transfer tubes 22 into the second header section 53 of the turnback side header 50 becomes a gas-liquid two phase refrigerant, in which a liquid phase and a gas phase are mixed, by some of the refrigerant changing from the gas phase to the liquid phase.

[0043]

As illustrated in Fig. 5, out of gas-liquid two phase refrigerant supplied into the second header section 53, a refrigerant with a high liquid phase content and a high density gathers at the lower portion of the second header section 53 due to gravity, and a refrigerant with a high gas phase content and a low density gathers at the upper

portion of the second header section 53. As a consequence, the refrigerant with a high gas phase content is introduced into the first connecting tube 55 connected to the upper portion of the second header section 53, and is introduced into the lower portion of the first header section 52 via the first connecting tube 55. On the other hand, the refrigerant with a high liquid phase content is introduced into the second connecting tube 56 connected to the lower portion of the second header section 53, and is introduced into the upper portion of the first header section 52 via the second connecting tube 56. Accordingly, in the first header section 52, the homogenization of a gas-liquid ratio of a refrigerant in the entire first header section 52 is achieved, as in the second header section 53 in a case where the heat exchanger 10 is used as an evaporator.

[0044]

Herein, in a case where the heat exchanger 10 is used as a condenser, the flow rate in each of the plurality of first heat transfer tubes 21 to which the refrigerant is supplied from the first header section 52 becomes higher as head differences (heights of the first heat transfer tubes 21 in the entrance side header 40) of the first heat transfer tubes 21 become larger. For this reason, a cooling effect from external atmosphere is small in the first heat transfer tubes 21 with low flow rates, and a cooling effect from

external atmosphere is larger in the first heat transfer tubes 21 with high flow rates. When variations in a cooling effect caused by each of the first heat transfer tubes 21 occur as described above, a performance decrease of the entire heat exchanger 10 is caused.

[0045]

In a case where a gas phase content is high in the upper portion of the first header section 52, a cooling effect in the first heat transfer tubes 21 disposed on the upper side is small. Therefore, a refrigerant cannot be sufficiently condensed. On the other hand, in a case where a liquid phase content is high in the lower portion of the first header section 52, a cooling effect in the first heat transfer tubes 21 disposed on the lower side is large. Therefore, a refrigerant is overcooled.

For this reason, since the homogenization of a gas-liquid ratio in the first header section 52 is achieved as described above in the embodiment, the inconvenience can be suppressed in a case where the heat exchanger 10 is used as a condenser.

[0046]

Even in a case where the heat exchanger 10 is used as any one of an evaporator and a condenser, the lower portion of the turnback side header 50 is set as the first header section 52 and the upper portion of the turnback side header

is set as the second header section 53 in the embodiment. Therefore, oil separated out from a refrigerant can be introduced into the first header section 52 via the second connecting tube 56 without staying in the lower portion of the second header section 53. Accordingly, since the oil is mixed with the refrigerant in the first header section 52, the insufficiency of oil in a refrigerant can be avoided when carrying out a refrigerating cycle in the refrigerant circuit.

[0047]

Next, a heat exchanger 60 according to a second embodiment of the invention will be described with reference to Fig. 6 and Fig. 7. In the second embodiment, the same configuration elements as the first embodiment will be assigned with the same reference signs as the first embodiment, and the detailed description thereof will be omitted.

As illustrated in Fig. 6 and Fig. 7, the heat exchanger 60 of the second embodiment is different from the first embodiment in that the turnback side header 50 further includes a second header partition plate 61.

[0048]

The second header partition plate 61 partitions a space in the second header section 53 into two upper and lower regions. A lower region, out of the two regions, is

set as a second lower region 63, and an upper region is set as a second upper region 64. The second lower region 63 and the second upper region 64 each communicate with the second heat transfer tubes 22. In addition, the second lower region 63 communicates with the other end of the second connecting tube 56, and the second upper region 64 communicates with the other end of the first connecting tube 55.

[0049]

The second header partition plate 61 has a communication-hole 62 formed in the vertical direction. The second lower region 63 and the second upper region 64 are in a communicating state with each other via the communication-hole 62 at a portion in the horizontal direction. In other words, the second header partition plate 61 is formed so as to protrude from inner peripheral surfaces of the header body 51 to the inside such that a communicating state between the second lower region 63 and the second upper region 64 is allowed at a part in the horizontal direction.

The communication-hole 62 may be formed in the middle of the second header partition plate 61 in the horizontal direction, or may be formed off the middle.

[0050]

In the heat exchanger 60 including such a second header

partition plate 61, a gas and a liquid in the second header section 53 can be mixed more effectively than in the heat exchanger 10 of the first embodiment in a case where the heat exchanger 60 is used in particular as an evaporator.

That is, in the case of the heat exchanger 10 of the first embodiment, a refrigerant with a high liquid phase content and a high density, which is supplied from the upper portion of the second header section 53, falls quickly down to the lower portion of the second header section 53 due to gravity. Therefore, a liquid phase content becomes higher in the lower portion of the second header section 53 in some cases.

In particular, this is more conspicuous in a case where the amount of a refrigerant supplied from the upper portion of the second header section 53 is large.

[0051]

On the contrary, since there is the second header partition plate 61 in the embodiment, a refrigerant with a high liquid phase content introduced from the upper portion of the second header section 53 temporarily stays in the second upper region 64 instead of moving quickly to the lower portion of the second header section 53. Since the refrigerant with a high gas phase content introduced from the lower portion of the second header section 53 is blown upwards to the second upper region 64 via the communication-

hole 62, a gas phase content can be stably supplied to the second upper region 64. Accordingly, it can be suppressed that a liquid phase content becomes excessive in the second lower region 63 of the second header section 53, and it can be suppressed that a gas phase content becomes excessive in the second upper region 64. Accordingly, the mixing of a gas phase content and a liquid phase content can be caused more efficiently in the entire second header section 53.

[0052]

Although an example in which one second header partition plate 61 is provided in the second header section 53 is described in the embodiment, a plurality of the second header partition plates 61 may be provided at intervals in the vertical direction in the second header section 53. It is preferable that each of a plurality of vertically partitioned regions communicate with the second heat transfer tubes 22. In addition, it is preferable that the other end of the second connecting tube 56 be connected to the lowermost region, out of the plurality of regions, and the other end of the first connecting tube 55 be connected to the uppermost region.

In a case where the plurality of second header partition plates 61 are provided, it is preferable that the communication-holes 62 formed in the respective second header partition plates 61 be formed at positions where the

communication-holes do not overlap each other when seen from the vertical direction. Accordingly, a liquid phase content can be caused to stay in each region more effectively, and it is possible to mix a gas and a liquid more efficiently in each region.

[0053]

Next, a heat exchanger 70 according to a third embodiment of the invention will be described with reference to Fig. 8 to Fig. 10. In the third embodiment, the same configuration elements as the first embodiment will be assigned with the same reference signs as the first embodiment, and the detailed description thereof will be omitted.

As illustrated in Fig. 8 to Fig. 10, the heat exchanger 70 of the third embodiment is different from the first embodiment in that the turnback side header 50 further includes a first header partition plate 71.

[0054]

The first header partition plate 71 partitions a space in the first header section 52 into two upper and lower regions. A lower region, out of the two regions, is set as a first lower region 72, and an upper region is set as a first upper region 73. The first lower region 72 and the first upper region 73 each communicate with the first heat transfer tubes 21. In addition, the first lower region 72

communicates with one end of the first connecting tube 55, and the first upper region 73 communicates with one end of the second connecting tube 56.

The first lower region 72 and the first upper region 73 are in a state of not communicating with each other in the first header section 52.

[0055]

An operational effect in a case where the heat exchanger 70 according to the third embodiment of the invention is used as an evaporator will be described.

A liquid-gas ratio of a refrigerant introduced into the first header section 52 via the first heat transfer tubes 21 is different for each of the first heat transfer tubes 21. In particular, as illustrated in Fig. 9, a refrigerant introduced from the first heat transfer tubes 21 positioned on the upper side into the first header section 52 has a higher gas phase content, and a refrigerant introduced from the first heat transfer tubes 21 positioned on the lower side into the first header section 52 has a higher liquid phase content. For this reason, since the first header partition plate 71 partitions the first header section 52 into the first lower region 72 and the first upper region 73, the gas phase-liquid phase ratios of refrigerants supplied to the lower portion and the upper portion of the second header section 53 via the first

connecting tube 55 and the second connecting tube 56 can be stabilized.

In addition, the gas-liquid ratios or flow rates of refrigerants supplied to the lower portion and the upper portion of the second header section 53 can be adjusted so as to be desired values by adjusting the vertical position of the first header partition plate 71.

[0056]

Next, an operational effect in a case where the heat exchanger 70 according to the third embodiment of the invention is used as a condenser will be described.

In the embodiment, a refrigerant with a high gas phase content is supplied to the first lower region 72 of the first header section 52, and a refrigerant with a high liquid phase content is supplied to the first upper region 73.

For this reason, in a case where the flow rates of the first heat transfer tubes 21 positioned on the lower side, out of the plurality of first heat transfer tubes 21, are low and a cooling effect is relatively large due to a difference in the headers 30 as described above, a refrigerant circulating in that first heat transfer tubes 21 has a high gas phase content. Therefore, the refrigerant can be appropriately condensed without overcooling. On the other hand, even in a case where the flow rates of the first

heat transfer tubes 21 positioned on the upper portion, out of the plurality of first heat transfer tubes 21, are high and a cooling effect is relatively small due to a difference in the headers 30, a refrigerant circulating in that first heat transfer tubes 21 already has a high condensed liquid phase content. Therefore, there is no inconvenience.

Thus, a refrigerant can be more efficiently condensed in the entire heat exchanger 70.

[0057]

Next, a heat exchanger 80 according to a fourth embodiment of the invention will be described with reference to Fig. 11.

The heat exchanger 80 of the fourth embodiment is different from the first to third embodiments in that the shapes of a first connecting tube 81 and a second connecting tube 82 are flat tubular as illustrated in Fig. 11.

[0058]

That is, the first connecting tube 81 and the second connecting tube 82 of the fourth embodiment are connected to the first header section 52 and the second header section 53 as the first connecting tube 55 and second connecting tube 56 of the first embodiment to the third embodiment, and have the same structure as the heat transfer tubes 20 of the first to third embodiments, that is, the first connecting tube and the second connecting tube have a flat

tubular shape having a plurality of flow passages arranged at intervals in one direction therein. For this reason, in the first connecting tube 81 and the second connecting tube 82 of the fourth embodiment, a large amount of refrigerants circulating inside can be secured and a pressure loss of a refrigerant can be reduced, compared to the first connecting tube 55 and the second connecting tube 56 having circular sections of the first to third embodiments.

[0059]

Although the embodiments of the invention are described, the invention is not limited thereto, and can be modified as appropriate without departing from the technical scope of the invention.

[0060]

An example in which the first header section 52 and the second header section 53 are formed integrally with the header body 51 of the turnback side header 50 is described in the embodiments. Without being limited thereto, however, for example, the first header section 52 and the second header section 53 may be disposed independently of each other, as in a first modification example illustrated in Fig. 12. In this case, the first connecting tube 55 and the second connecting tube 56 are connected to the first header section 52 and the second header section 53 such that the first connecting tube and the second connecting tube

cross each other. Although the first header section 52 and the second header section 53 are disposed at the same vertical position in the first modification example, the first header section and the second header section may be disposed at vertical positions different from each other.

[0061]

For example, as in a second modification example illustrated in Fig. 13, the turnback side header 50 may be configured to be provided with two sets of the first header sections 52 and the second header sections 53, and the entrance side header 40 may be configured to be provided with a set of the first header section 52 and the second header section 53 such that a configuration where a refrigerant, which has returned to the entrance side header 40, is again supplied to the turnback side header 50 and then returns to the entrance side header 40 is adopted.

[0062]

For example, as in a third modification example illustrated in Fig. 14, the heat exchanger 10 of the embodiment may be configured such that the first header section and the second header section are vertically disposed for each of two stages.

In addition, for example, as in a fourth modification example illustrated in Fig. 15, a configuration, in which the vertically adjacent first header sections 52 and the

vertically adjacent second header sections 53 are provided in the turnback side header 50, the first header sections 52 and the second header sections 53 are provided such that the first header sections 52 and the second header sections 53 are vertically sandwiched, and the inside of the entrance side header 40 is partitioned so as to correspond thereto, may be adopted.

Industrial Applicability

[0063]

The heat exchanger and the air conditioner according to one aspect of the invention can achieve the suppression of an efficiency decrease.

Reference Signs List

[0064]

- 1 air conditioner
- 2 compressor
- 3 indoor heat exchanger
- 4 expansion valve
- 5 outdoor heat exchanger
- 6 four-way valve
- 7 pipe
- 10 heat exchanger
- 20 heat transfer tube
- 21 first heat transfer tube
- 22 second heat transfer tube

23 fin
30 header
40 entrance side header
41 partition plate
42 lower entry region
43 upper entry region
50 turnback side header
51 header body
52 first header section
53 second header section
54 main partition plate
55 first connecting tube
56 second connecting tube
60 heat exchanger
61 second header partition plate
62 communication-hole
63 second lower region
64 second upper region
70 heat exchanger
71 first header partition plate
72 first lower region
73 first upper region
80 heat exchanger
81 first connecting tube
82 second connecting tube

Claims

[Claim 1]

A heat exchanger comprising:

a plurality of first heat transfer tubes that extend in a horizontal direction to allow a refrigerant to circulate therein, and are arranged at intervals in a vertical direction;

a first header section that has a cylindrical shape extending in the vertical direction and is connected to one end of each of the plurality of first heat transfer tubes in a communicating state;

a plurality of second heat transfer tubes that extend in the horizontal direction to allow the refrigerant to circulate therein, and are arranged at intervals in the vertical direction;

a second header section that is connected to one end of each of the plurality of second heat transfer tubes in a communicating state;

a first connecting tube that connects a lower portion of the first header section and an upper portion of the second header section together; and

a second connecting tube that connects an upper portion of the first header section and a lower portion of the second header section together.

[Claim 2]

The heat exchanger according to Claim 1, further comprising:

a second header partition plate that partitions a space in the second header section into a second upper region communicating with the first connecting tube and a second lower region communicating with the second connecting tube and has a communication-hole formed vertically therethrough.

[Claim 3]

The heat exchanger according to Claim 1 or 2, further comprising:

a first header partition plate that partitions a space in the first header section into a first lower region communicating with the first connecting tube and a first upper region communicating with the second connecting tube.

[Claim 4]

The heat exchanger according to any one of Claims 1 to 3,

wherein at least one of the first connecting tube and the second connecting tube has a flat tubular shape having a plurality of flow passages arranged at intervals therein.

[Claim 5]

The heat exchanger according to any one of Claims 1 to 4, further comprising:

a header,

wherein the header has a header body, which has a cylindrical shape extending in the vertical direction, and a main partition plate which partitions an inside of the header body into upper and lower parts,

the first header section is a portion below the main partition plate in the header body, and

the second header section is a portion above the main partition plate in the header body.

[Claim 6]

An air conditioner comprising the heat exchanger according to any one of Claims 1 to 5.

1/11
FIG. 1

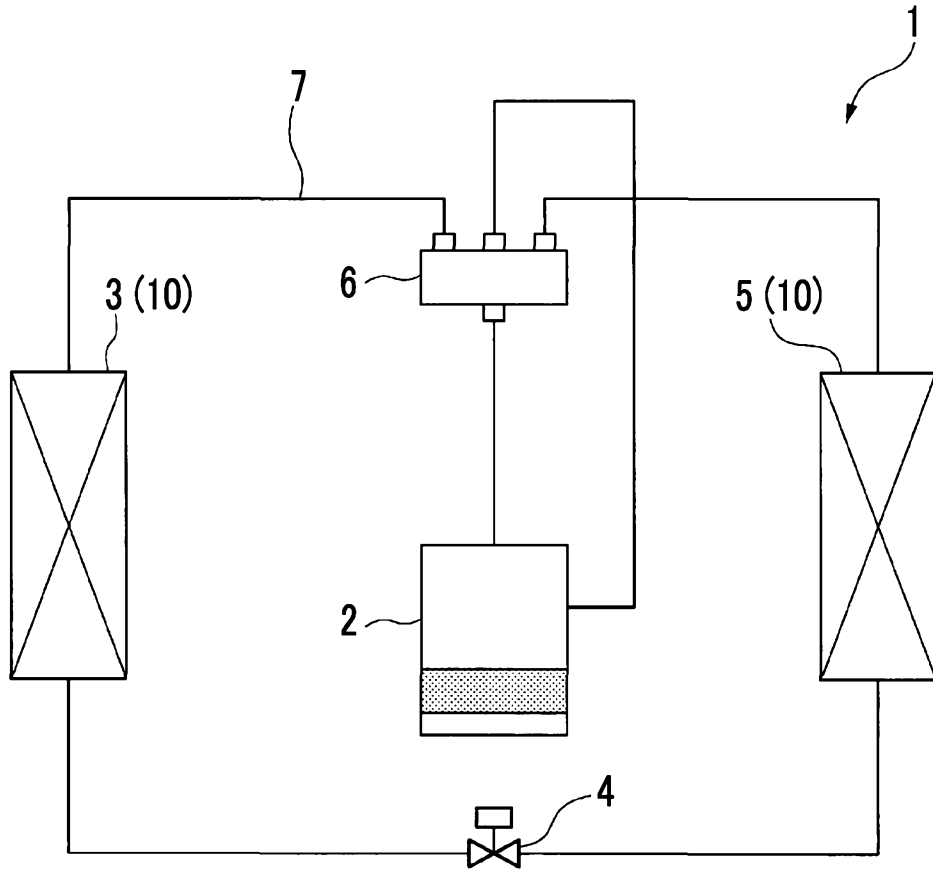

2/11
FIG. 2

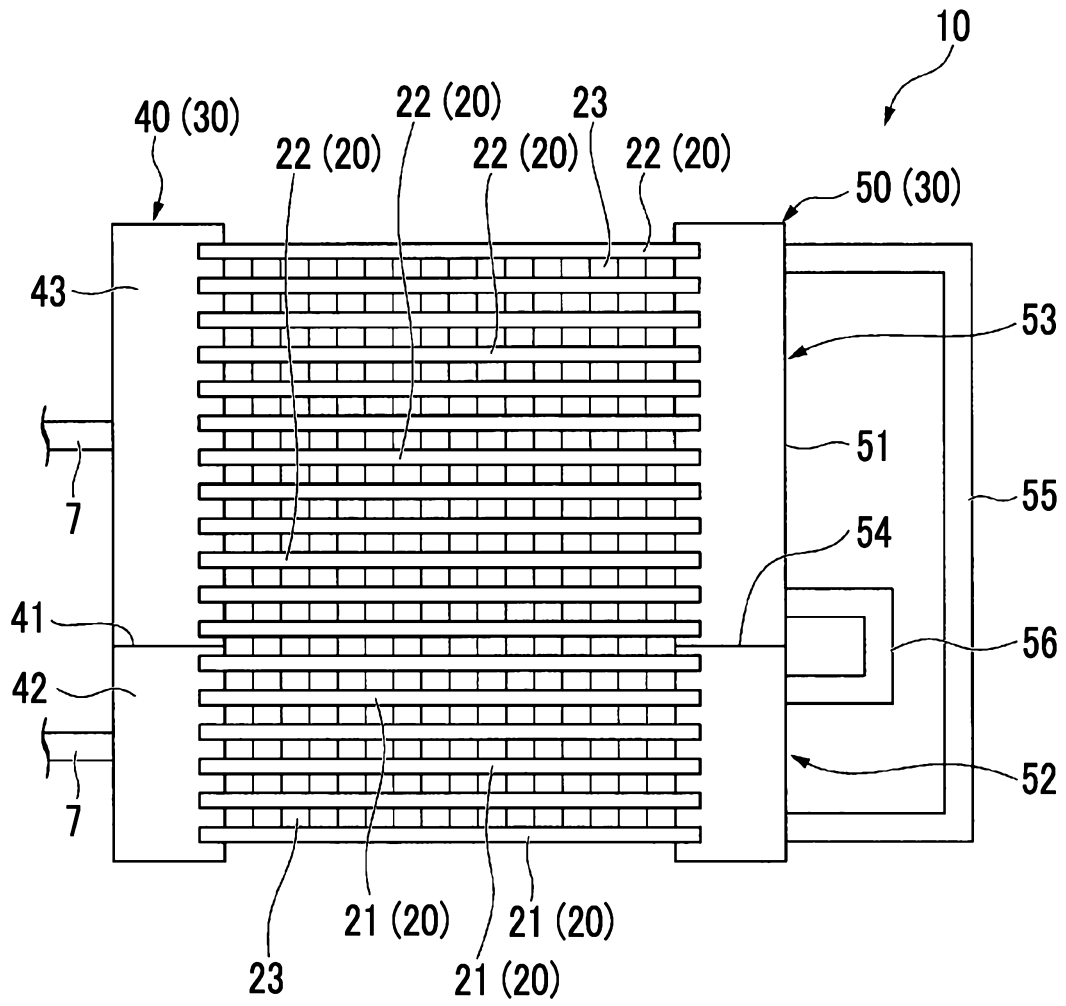

3/11
FIG. 3

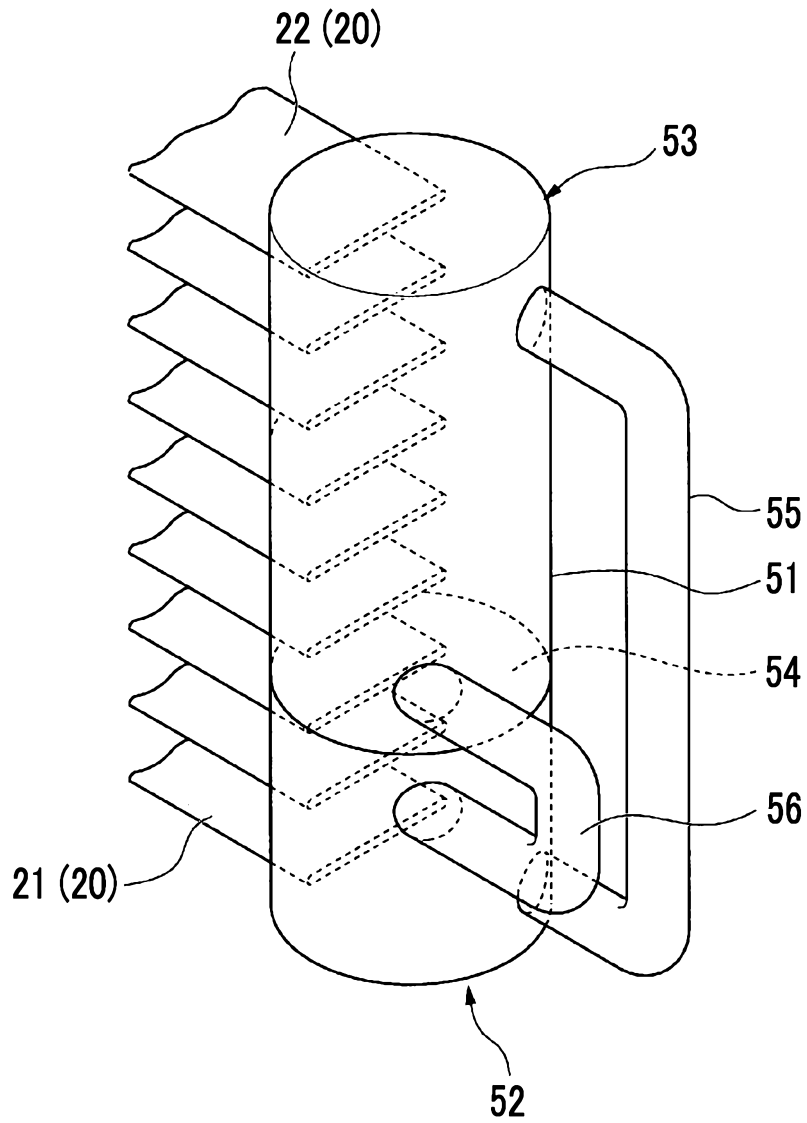

4/11
FIG. 4

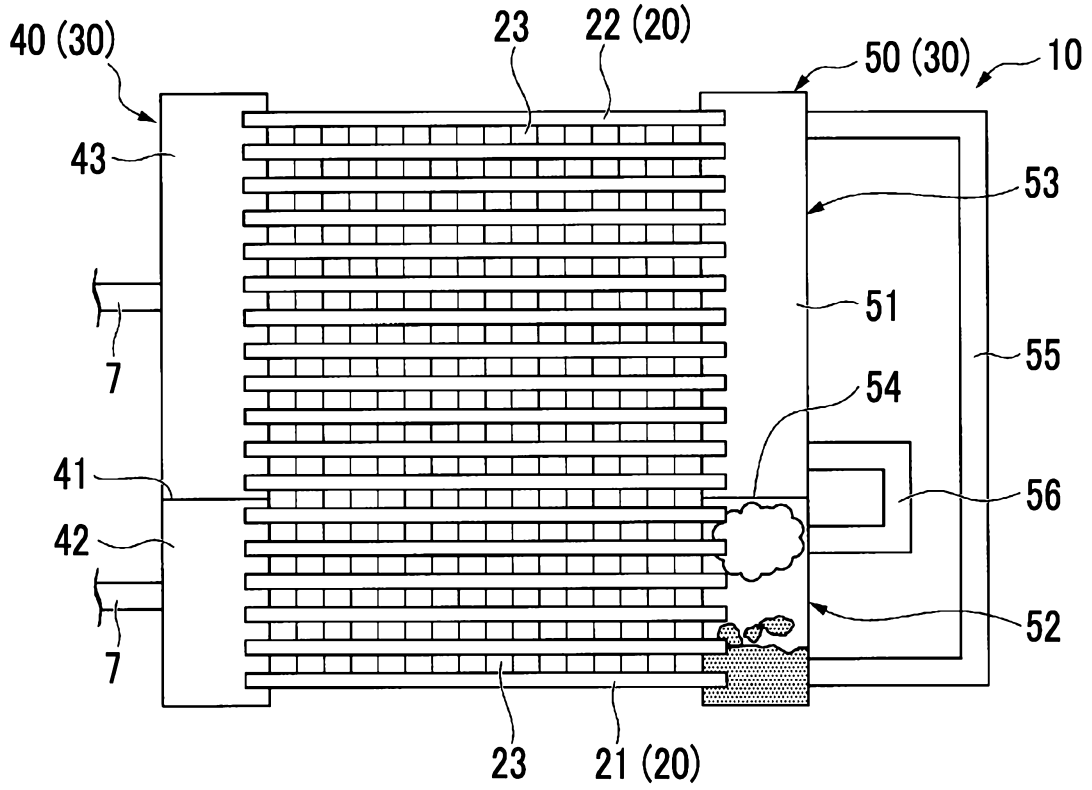
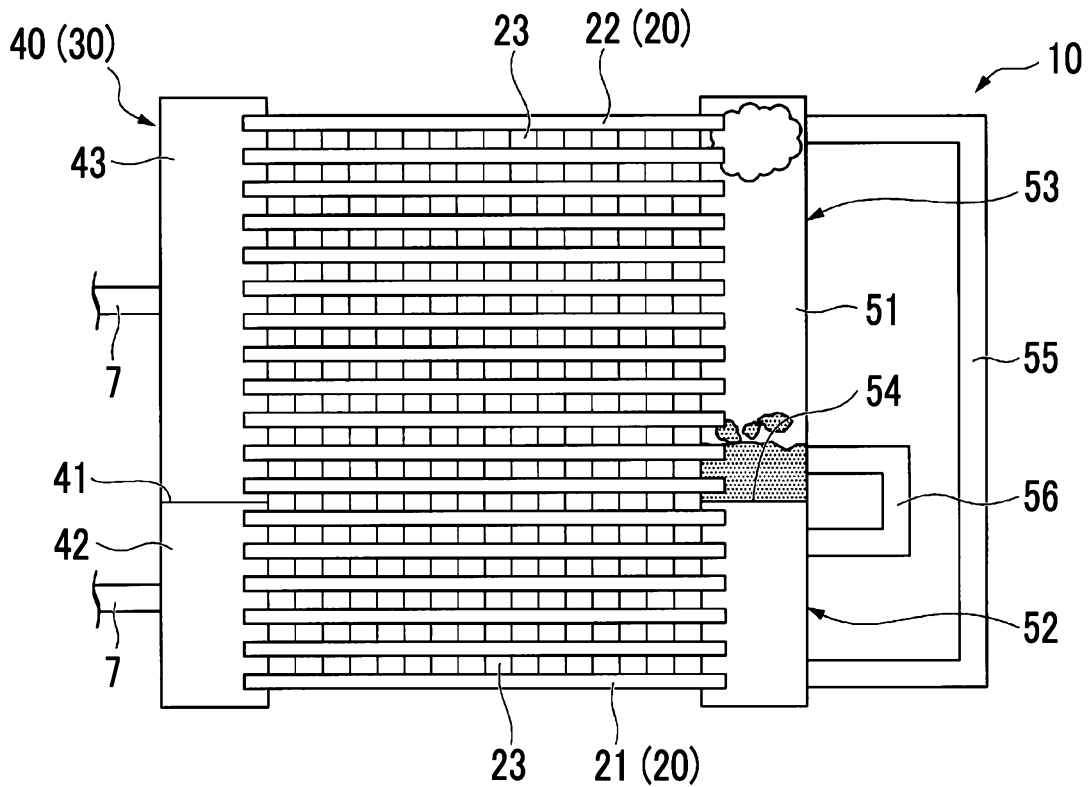
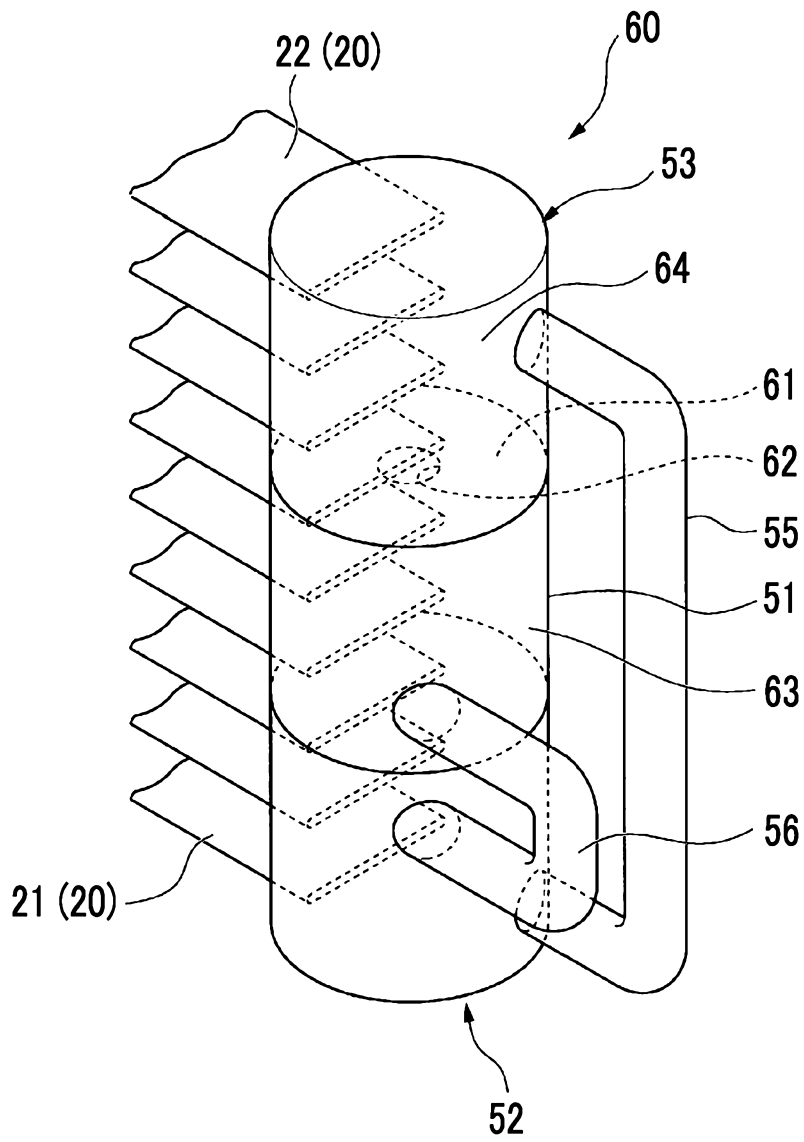

FIG. 5



5/11
FIG. 6



6/11
FIG. 7

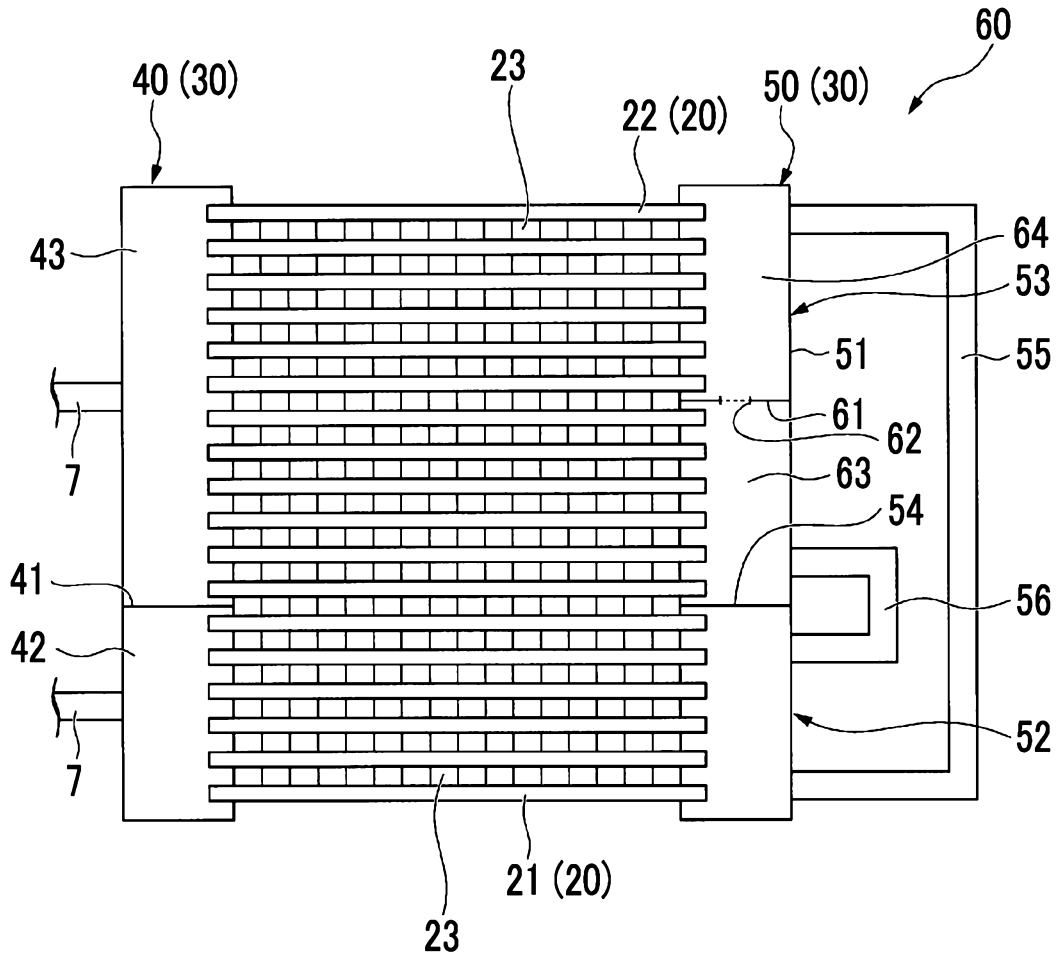

7/11
FIG. 8

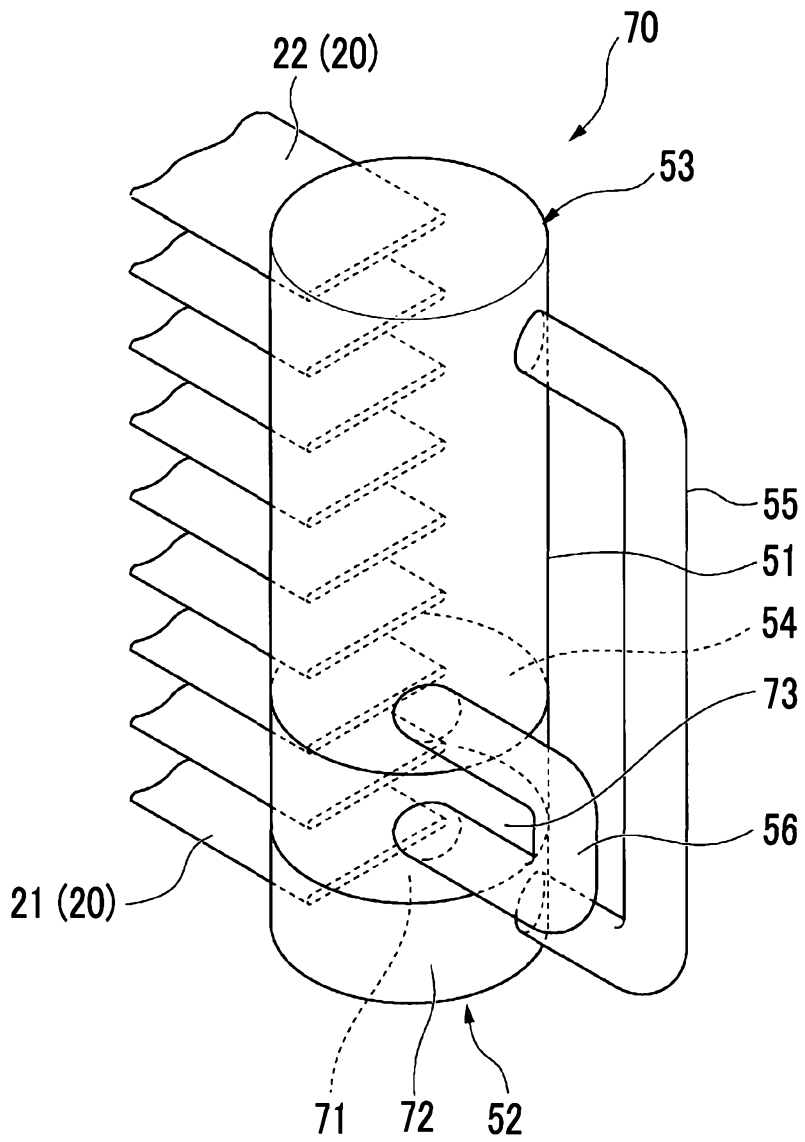

8/11
FIG. 9

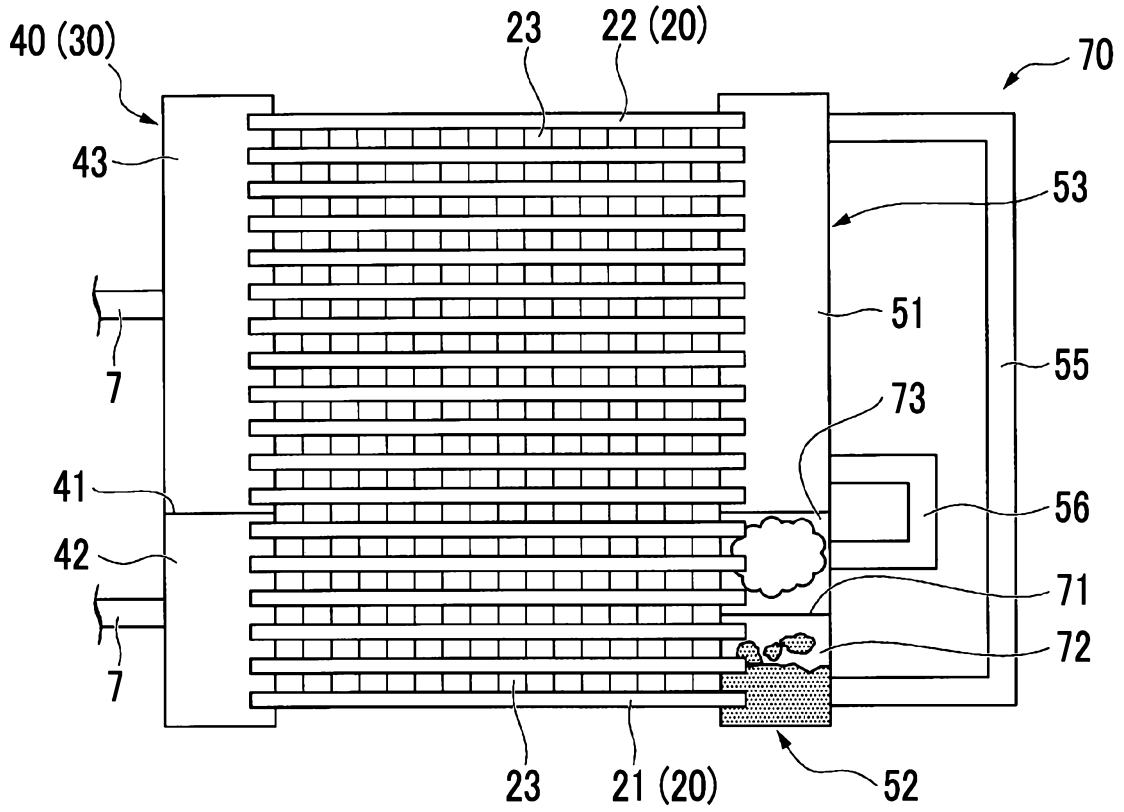
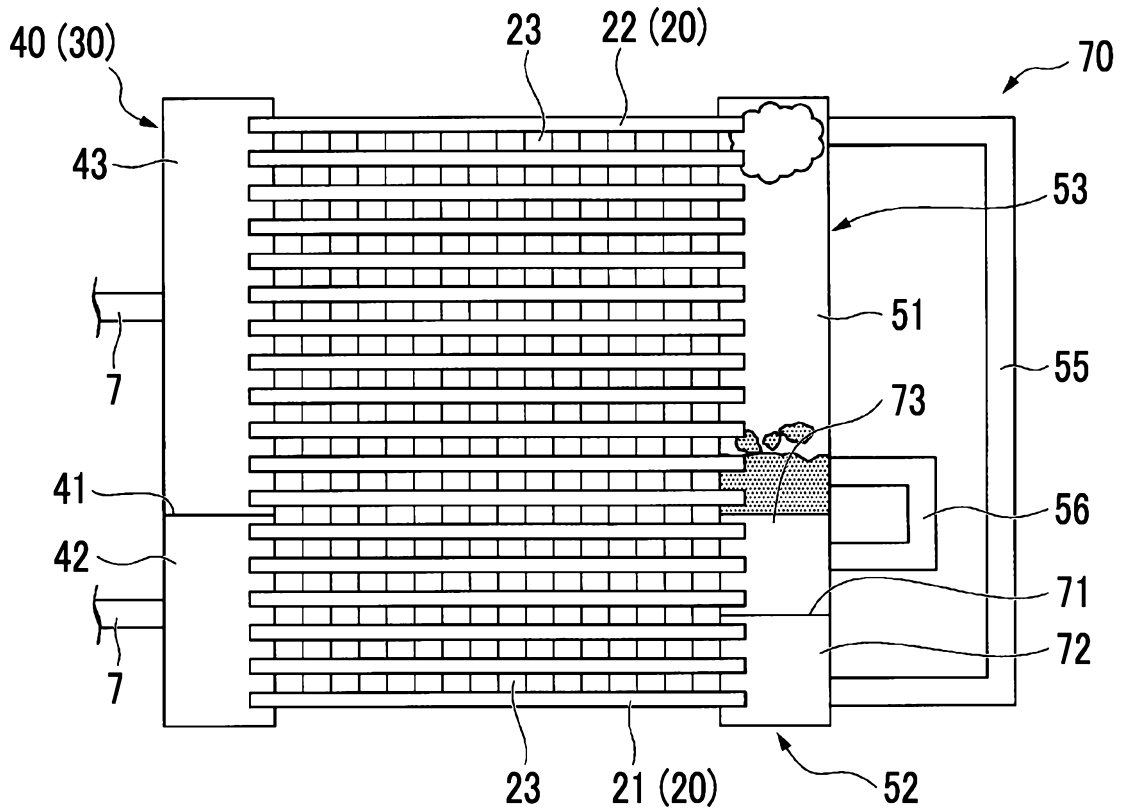

FIG. 10



9/11
FIG. 11

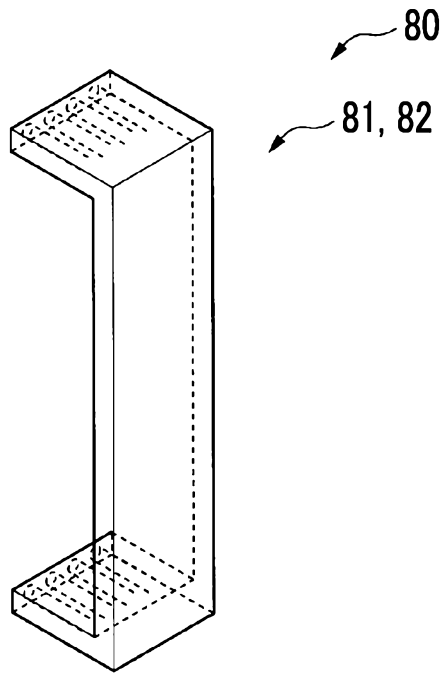
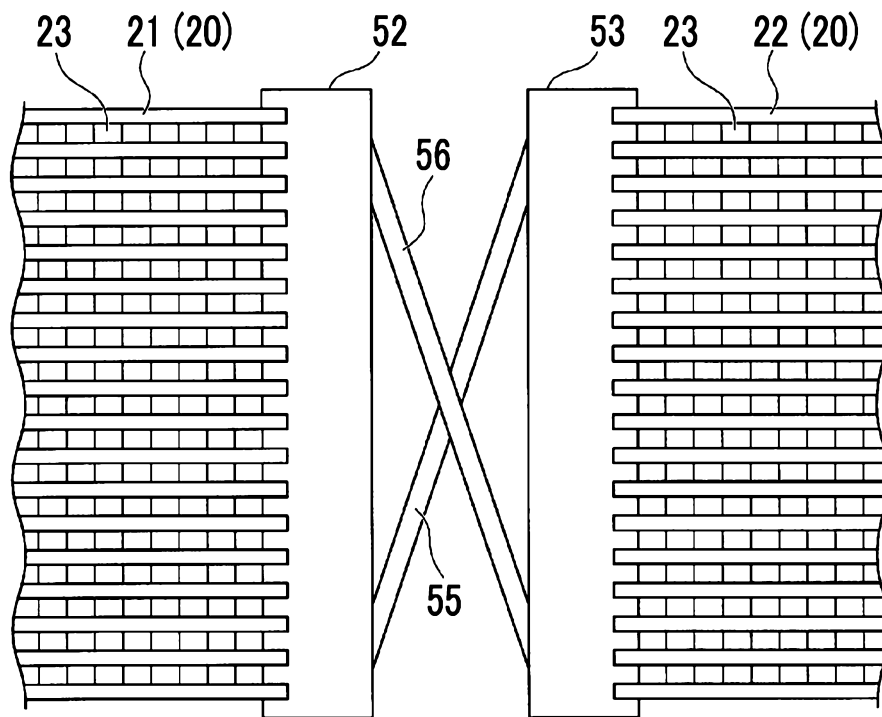
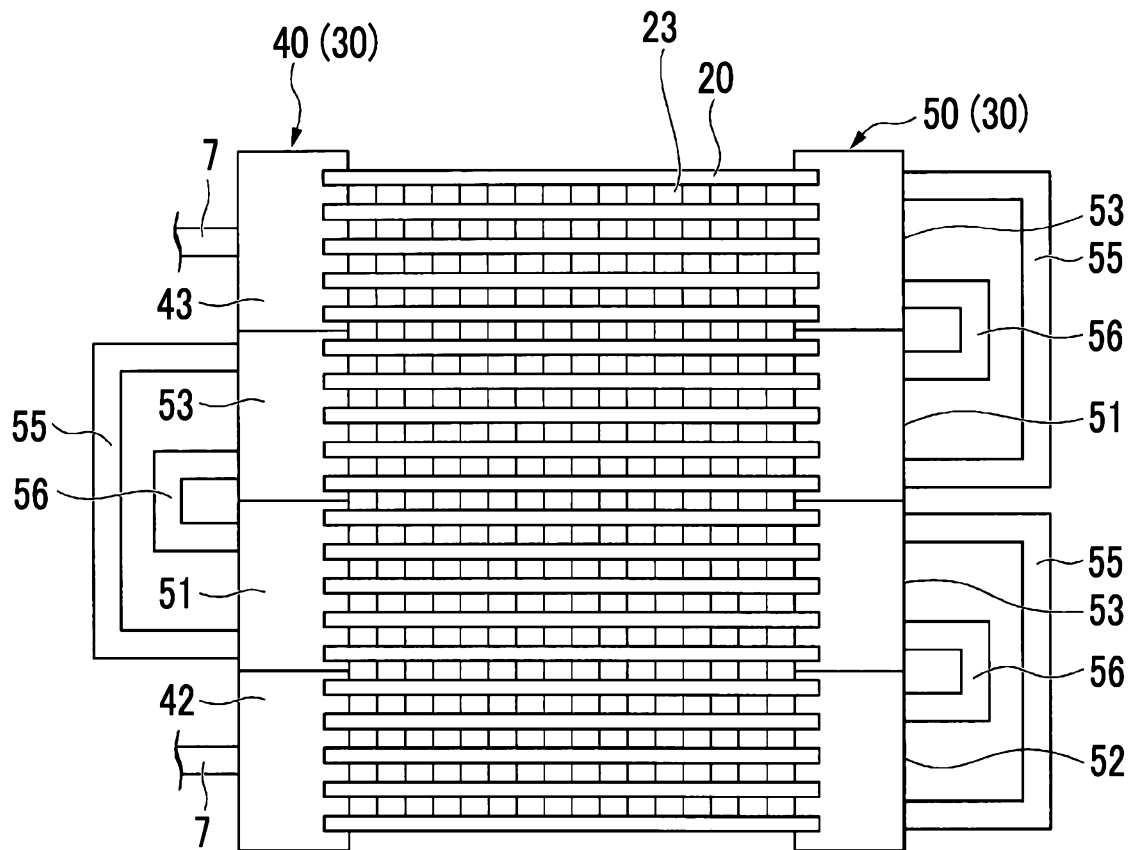

FIG. 12



10/11
FIG. 13



11/11
FIG. 14

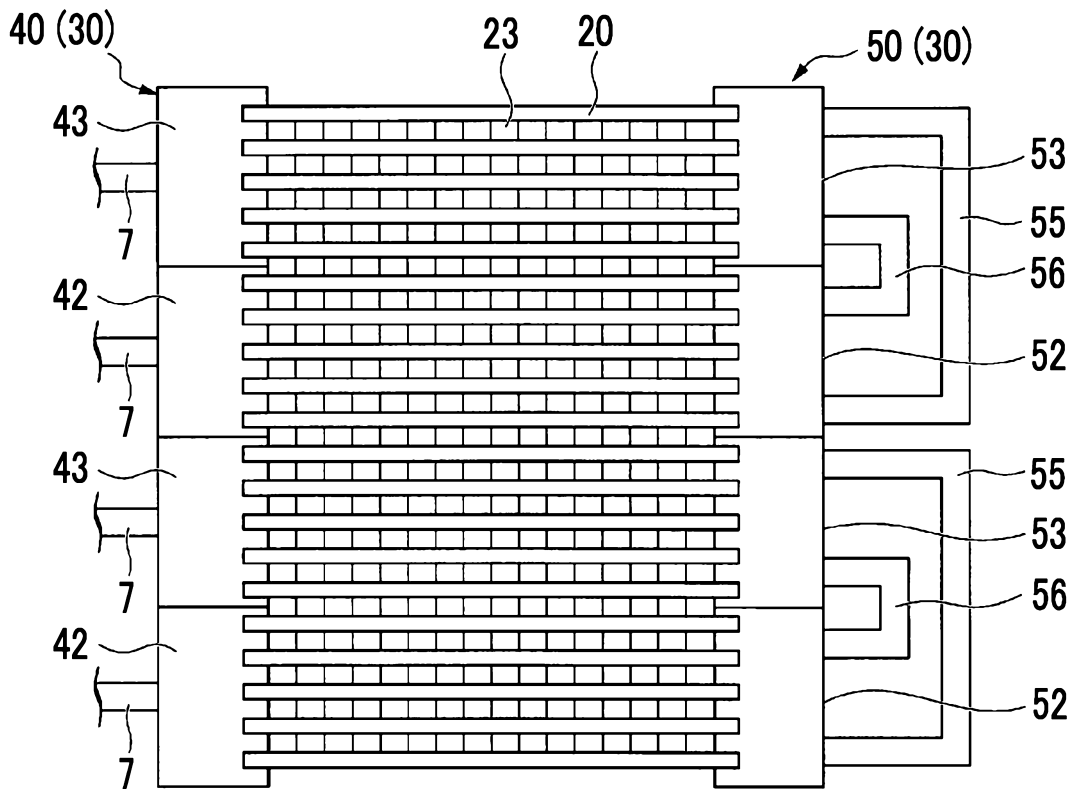

FIG. 15

