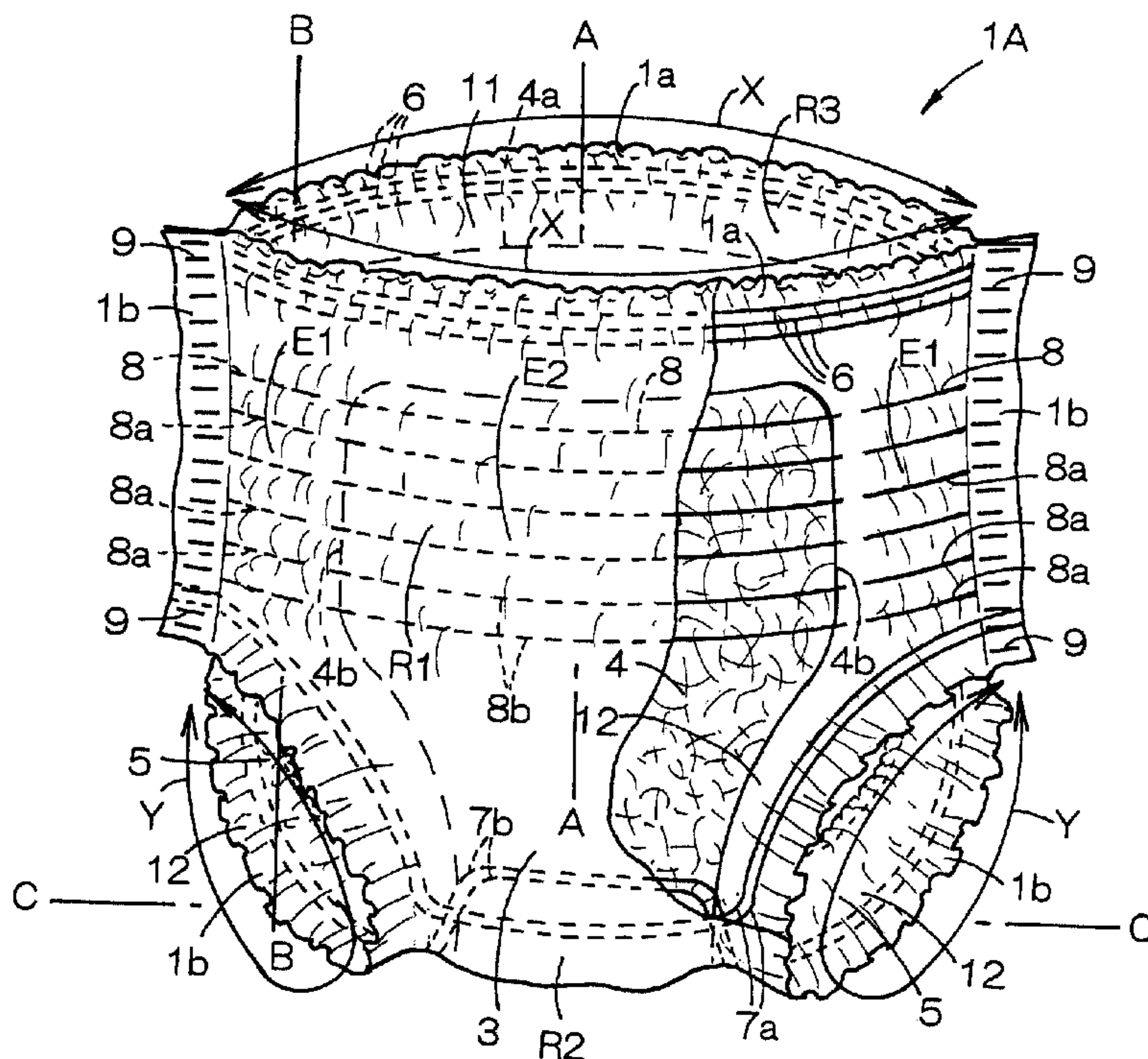




(22) Date de dépôt/Filing Date: 2001/10/12  
(41) Mise à la disp. pub./Open to Public Insp.: 2002/04/13  
(30) Priorité/Priority: 2000/10/13 (2000-314189) JP

(51) Cl.Int.<sup>7</sup>/Int.Cl.<sup>7</sup> A61F 13/49  
(71) Demandeur/Applicant:  
UNI-CHARM CORPORATION, JP  
(72) Inventeurs/Inventors:  
SHIMADA, TAKAAKI, JP;  
NAKAMURA, KENJI, JP  
(74) Agent: OGILVY RENAULT

(54) Titre : VETEMENT A CEINTURE ELASTIQUE JETABLE  
(54) Title: DISPOSABLE PULL-ON GARMENT



(57) Abrégé/Abstract:

A disposable pull-on garment includes each of front and rear waist-encircling regions R1, R3 which has a first elasticized zone E1 and a second elasticized zone E2 extending in a waist-encircling direction. Auxiliary elastic members 8 include plural lines of first auxiliary elastic members 8a extending in the waist-encircling direction in the first elasticized zone E1, and plural lines of second auxiliary elastic members 8b extending in the waist-encircling direction in the second elasticized zone E2. A tensile stress of the first auxiliary elastic members 8a is greater than that of the second auxiliary elastic member 8b. A tensile stress of the first elasticized zones E1 is greater than that of the second elasticized zone E2.

## A B S T R A C T

## DISPOSABLE PULL-ON GARMENT

5           A disposable pull-on garment includes each of front and  
rear waist-encircling regions R1, R3 which has a first  
elasticized zone E1 and a second elasticized zone E2 extending  
in a waist-encircling direction. Auxiliary elastic members 8  
include plural lines of first auxiliary elastic members 8a  
10 extending in the waist-encircling direction in the first  
elasticized zone E1, and plural lines of second auxiliary  
elastic members 8b extending in the waist-encircling direction  
in the second elasticized zone E2. A tensile stress of the first  
auxiliary elastic members 8a is greater than that of the second  
15 auxiliary elastic member 8b. A tensile stress of the first  
elasticized zones E1 is greater than that of the second  
elasticized zone E2.

## DISPOSABLE PULL-ON GARMENT

This invention relates to a disposable pull-on garment which absorbs and retains excrements.

5 Japanese Patent Application Publication No. 1995-236650A discloses a disposable pull-on diaper which comprises a liquid pervious top sheet, a liquid impervious back sheet and an liquid absorbent core interposed between those two sheets, with respective longitudinal side edges of front and rear waist-  
10 encircling regions being secured to each other to provide a waist-encircling opening and a pair of leg-encircling openings. In the front waist-encircling region, a plurality of waist elastic members extending in a waist-encircling direction are secured in an extended state to an edge portion of the  
15 waist-encircling opening. To an edge portion of each leg-encircling opening, a plurality of leg elastic members are secured in an extended state extending in a leg-encircling direction. Also, a plurality of auxiliary elastic members extending in the waist-encircling direction between the  
20 longitudinal side edges of the front and rear waist regions are secured in a region between the waist elastic members and the leg-encircling opening edge portions.

Each auxiliary elastic member has an extensible portion



- 2 -

and a non-extensible portion. The extensible portion extends from longitudinal side edges of the core positioned over the front and rear waist-encircling regions toward respective longitudinal side edges of the front waist-encircling region.

5 The non-extensible portion traverses the core to extend between opposite longitudinal side edges of the core. The extensible portions of the auxiliary elastic members act to tighten a wearer's waist so that the diaper while in use is prevented from sliding down from its position. In the non-extensible portions

10 of the auxiliary elastic members, the diaper is not subjected to an tensile stress from the auxiliary elastic members which may otherwise cause the core to contract, so that the core is prevented from puckering.

The diaper disclosed in the above Publication relies

15 solely on the extensible portions of auxiliary elastic members to prevent its downward slide and accordingly needs to increase a tensile stress of the auxiliary elastic members in their extensible portions. Such a diaper thus is pressed strongly against a wearer's waist and provides discomfort to a wearer

20 of the diaper. The non-extensible portions of the auxiliary elastic members do not act to press the core against a wearer's skin. This enhances a possibility of the core to be spaced away from the wearer's skin while in use of the diaper, and

- 3 -

accordingly reduces an excrement-absorbing function of the core.

It is an object of this invention to provide a disposable  
5 pull-on garment which does not press itself locally against a waist encircling region of its wearer and does not reduce a function of the core of to absorb excrements.

According to the present invention, there is provided a disposable pull-on garment, which comprises a liquid pervious  
10 top sheet, a liquid impervious back sheet and a liquid absorbent core interposed between those sheets. The garment includes front and rear waist-encircling regions opposed to each other, a crotch region positioned between the front and rear waist-encircling regions, a waist-encircling opening, a pair  
15 of leg-encircling openings defined by joining respective longitudinal sides edges of the front and rear waist-encircling regions. The waist-encircling elastic members are attached in an extended state to an edge portion of the waist-encircling opening in at least one of the front and rear waist-encircling  
20 regions, wherein a plurality of auxiliary elastic members spaced longitudinally from each other at a pre-determined distance and extending in the waist-encircling direction are attached in an extended state to a region between the waist

- 4 -

elastic members and the edge portion of the leg-encircling opening in at least one of the front and rear waist-encircling regions.

A first feature of this invention is that each of the front  
5 and rear waist-encircling regions has a first elasticized zone extending in the waist-encircling direction between the vicinities of opposite side edges of the core positioned in the waist-encircling region, and a second elasticized zone extending across the core in the waist-encircling direction  
10 between the vicinities of opposite side edges of the core, wherein the auxiliary elastic members include a plurality of first auxiliary elastic members extending in the waist-encircling direction in the first elasticized zone and a plurality of second auxiliary elastic members extending in the  
15 waist-encircling direction in the second elasticized zone, and that a tensile stress of the first auxiliary elastic members is greater than that of the second auxiliary elastic members and a tensile stress of the first elasticized zone is greater than that of the second elasticized zone.

20 A second feature of this invention is that each of the front and rear waist-encircling regions has a first elasticized zone extending in the waist-encircling direction between the vicinities of opposite side edges of the core positioned in the



- 5 -

waist-encircling region, and a second elasticized zone extending across the core in the waist-encircling direction between the vicinities of opposite side edges of the core, wherein the auxiliary elastic members include a plurality of first auxiliary elastic members extending in the waist-encircling direction in the first elasticized zone and a plurality of second auxiliary elastic members extending in the waist-encircling direction in the second elasticized zone, and that a tensile stress of the first auxiliary elastic members is greater than or equal to that of the second auxiliary elastic member and the number of the first auxiliary elastic members is larger than that of the second auxiliary elastic members.

According to one exemplary embodiment of the present invention, the first elasticized zone when extended to its maximum extent exhibits an tensile stress in a range of 0.2 - 2.0 N/25 mm, and the second elasticized zone when extended to its maximum extent exhibits an tensile stress in a range of 0.1 - 0.6 N/25 mm.

Figure 1 is a partially cut-away perspective view of a disposable diaper as one exemplary garment;

Figure 2 is a partially cut-away plan view of the diaper when the front and rear waist regions are disconnected from each

other and developed longitudinally;

Figure 3 is an end view taken along the line A-A of Figure  
1;

Figure 4 is an end view taken along the line B-B of Figure  
5 1;

Figure 5 is an end view taken along the line C-C of Figure  
1;

Figure 6 is a partially cut-away perspective view of a  
disposable diaper as another exemplary garment;

10 Figure 7 is a partially cut-away plan view of the diaper  
when the front and rear waist regions are disconnected from each  
other and developed longitudinally;

Figure 8 is a view similar to Figure 7 but viewed from  
a side of the top sheet;

15 Figure 9 is an end view taken along the line D-D of Figure  
5;

Figure 10 is an end view taken along the line E-E of Figure  
5;

Figure 11 is an end view taken along the line F-F of Figure  
20 5.

A disposable pull-on garment in accordance with the  
present invention is described below in detail with reference



- 7 -

to the attached drawings as is used in a disposable pull-on diaper.

Figure 1 is a partially cut-away perspective view of an illustrative disposable diaper 1A. Figure 2 is a partially cut-away plan view of the diaper 1A when its front and rear waist-encircling regions R1, R3 are disconnected from each other and developed in a longitudinal direction. In Figure 1, a waist-encircling direction is shown by the arrow X and a leg-encircling direction is shown by the arrow Y. In Figure 2, the diaper 1A is viewed from a side of its back sheet 3. A lateral direction and a longitudinal direction are shown by the arrows X and Y, respectively. An inside surface of the top or back sheet 2, 3 means its surface positioned to face toward a core 4. An outside surface of the top or back sheet 2, 3 means its surface positioned away from the core 4.

The diaper 1A comprises as major components a liquid pervious top sheet 2, a liquid impervious back sheet 3, and a liquid-absorbing core 4 interposed between the top and back sheets 2, 3 and wrapped entirely by and joined to a tissue paper (not shown), and a substantially liquid impervious, leakage-resistant cuff 5. The core 4 is joined via the tissue paper to inner surfaces of the top and back sheets 2 and 3.

The diaper 1A includes front and rear waist-encircling

- 8 -

regions R1 and R3 opposed to each other, and a crotch region R2 positioned between the front and rear waist-encircling regions R1, R3. A waist-encircling opening 11 and a pair of leg-encircling openings 12 are defined in the diaper 1A.

5           As shown in Figure 2, the diaper 1A has laterally-extending end edges 1a and longitudinally-extending side edges 1b. Each of the side edges 1b in the crotch region R2 shows a curved line toward a laterally inward direction of the diaper 1A.

10           A plurality of laterally-extending waist elastic members 6 are secured in an extended state along end edges 1a. In the crotch region R2, a plurality of leg elastic members 7 are secured in an extended state along side edges 1b. In each of the front and rear waist-encircling regions R1 and R3, a  
15           plurality of auxiliary elastic members 8 extending laterally and spaced longitudinally from each other at a pre-determined distance are secured in an extended state in a region between the waist and leg elastic members 6 and 7.

20           The diaper 1A is formed into a pull-on type by overlaying opposite side edges 1b in the front and rear waist-encircling regions R1 and R3 each other and securing them to each other at plural joints 9 intermittently arranged along the longitudinal direction.

- 9 -

In the diaper 1A, the end edges 1a of the diaper 1A in Fig. 2 define an edge portion 1a of the waist-encircling opening 11, and the side edges 1b of the diaper 1A in Fig. 2 define respective edge portions 1b of the leg-encircling openings 12 in the crotch region R2, as shown in Figure 1. The waist elastic members 6 extend in the waist-encircling direction in the edge portion 1a of the waist-encircling opening 11. The leg elastic members 7 extend in the leg-encircling direction along the edge portions 1b of each of leg-encircling openings 12. The auxiliary elastic members 8 extend in the waist-encircling direction in an area located between the waist elastic members 6 and the edge portions 1b of the leg-encircling openings 12.

Each of the front and rear waist-encircling regions R1, R3 of the diaper 1A has a first elasticized zone E1 and a second elasticized zone E2. The first elasticized zone E1 extends in the waist-encircling direction in the region between the vicinities of opposite side edges 4b of the core 4 positioned in the front and rear waist-encircling regions R1, R3 and the opposite side edges 1b of the front and rear waist-encircling regions, R1, R3. The second elasticized zone E2 traverses the core extending in the waist-encircling direction between the vicinities of opposite side edges 4b of the core 4.

The auxiliary elastic members 8 include plural lines of



- 10 -

first auxiliary elastic members 8a and plural lines of second auxiliary elastic members 8b. The first auxiliary elastic members 8a are spaced longitudinally from each other by a pre-determined distance and extend in the waist-encircling direction in the first elasticized zone E1. The second auxiliary elastic members 8b are spaced longitudinally from each other by a pre-determined distance and extend in the waist-encircling direction in the second elasticized zone E2. The number of the first auxiliary elastic members 8a is equal to that of the second auxiliary elastic members 8b. The first and second auxiliary elastic members 8a, 8b are related to each other on the tensile stress as the first auxiliary elastic member > the second auxiliary elastic member.

In the diaper 1A, the first elasticized zone E1 is related to the second elasticized zone E2 on tensile stress as the first elasticized zone E1 > the second elasticized zone E2. Also in the diaper 1A, the first elasticized zone E1 when extended to its maximum extent exhibits an tensile stress in a range of 0.2 - 2.0 N/25 mm, preferably in a range of 0.4 - 1.0 N/25 mm. In the second elasticized zone E2 when extended to its maximum extent exhibits a tensile stress in a range of 0.1 - 0.6 N/25 mm.

The following procedure is utilized to measure tensile

- 11 -

stress for the first and second elasticized zones E1 and E2.

(1) First, the first elasticized zone E1 is partially cut out to prepare a first test piece and the second elasticized zone E2 is partially cut out to prepare a second test piece. The first test piece includes portions of the first auxiliary elastic members 8a, and has a dimension of 100 mm in the waist-encircling direction and a dimension of 25 mm in the longitudinal direction. The second test piece includes portions of the second auxiliary elastic members 8b (excluding the core 4), and has a dimension of 100 mm in the waist-encircling direction and a dimension of 25 mm in the longitudinal direction.

(2) Then, the tensile stress of each test piece is measured using a tensile tester. Prior to the measurement of tensile stress, each test piece must be subjected to contraction by relieving the stress, and then extended by the tensile tester to a size of 100 mm. The tensile stress is a value measured when each test piece is elongated to a maximum size of 100 mm.

In the diaper 1A, the first elasticized zone E1 exhibits a higher value in the tensile stress than the second elasticized zone E2. Accordingly, when the diaper is worn, the first elasticized zone E1 tightens a wearer's waist more strongly than the second elasticized zone E2. However, in the diaper 1A, the first elasticized zone E1 together with the second elasticized

- 12 -

zone E2 tightens the wearer's waist in such a way as to prevent the diaper 1A from sliding down from its position. Thus, the tensile stress of the first elasticized zone E1 in this diaper is not required to be as high as that required for the prior art diaper construction so that it is sufficient for the tensile stress to be maintained within the above-specified range.

In the second elasticized zone E2 in the diaper 1A, the second auxiliary elastic members 8b press the core 4 against the wearer's skin by their tensile stress so that the core 4 of the diaper 1A while in use is prevented from being spaced away from the wearer's skin. As a result, such a situation as the excrement-absorbing function of the core 4 is reduced can be avoided. Since the tensile stress of the second elasticized zone E2 in the diaper 1A is maintained within the above-specified range, the core 4 due its rigidity withstands the force exerted by the second elasticized zone E2 when subjected to contraction and thus wrinkles will not be formed on the core 4.

If the tensile stress of the first elasticized zone E1 is below 0.2 N/25 mm, the pressing force of the first elasticized zone E1 around the wearer's waist becomes weak, increasing a possibility tendency of the diaper 1A to slide down from its position. If the tensile stress of the first elasticized zone



- 13 -

E1 exceeds 2.0 N/25 mm, the pressing force of the first elasticized zone E1 around the wearer's waist becomes stronger than necessary. The resulting strong pressure on the wearer's waist provides discomfort to the wearer of the diaper 1A. If  
5 the tensile stress of the second elasticized zone E2 is below 0.1 N/25 mm, it may fail to press the core 4 enough against the wearer's skin so that in some occasions, the core 4 is spaced away from the wearer's skin. If the tensile stress of the second elasticized zone E2 exceeds 0.6 N/25 mm, the core 4 may have  
10 wrinkles to pucker when the second elasticized zone E2 has contracted and, in some occasions the core 4 is spaced away from the wearer's skin.

The leakage-prevention cuff 5 extends longitudinally along each of the side edges 1b of the diaper 1A. Each cuff  
15 5 has a fixed edge 5a that extends longitudinally adjacent the side edges 4b of the core 4, a free edge 5b that is associated with the fixed edge 5a and biased to be spaced away from the top sheet 2, fixed ends 5c each folded laterally inwardly to overlay the top sheet 2, and side portion 5d (refer to Figure  
20 5) that extends from the fixed side edge 5a toward the side edges 1b of the diaper 1A. An elastic member 10 is attached in an extended state to the free edge 5b. The elastic member 10 is enclosed in a sleeve portion defined in the free edge 5b.

- 14 -

The leg-encircling elastic members 7 include a first leg elastic member 7a and a second leg elastic member 7b. Each of these leg elastic members 7a and 7b includes a central portion 7a<sub>1</sub>, 7b<sub>1</sub> that traverses the crotch region R2 and opposite side portions 7a<sub>2</sub>, 7b<sub>2</sub> that extend along the respective side edges 1b of the diaper. Each side portion 7a<sub>2</sub> of the first leg elastic member 7a is located in about a front half of the side edges 1b portion that extends in the crotch region R2. Each side portion 7b<sub>2</sub> of the second leg elastic member 7b is located in about a rear half of the side edge 1b portion that extends in the crotch region R2.

Figures 3 and 4 are end views taken along the line A-A and the line B-B of Figure 1, respectively. Figure 5 is an end view taken along the line C-C of Figure 1. In each side edge 1a of the diaper 1A, an end 2a of the top sheet and an end 3a of the back sheet 3 extend together outwardly from the side edge 4a of the core 4 where inward surfaces of those ends 2a, 3a are joined to each other, as shown in Figures 3 and 4. The waist elastic members 6 and the first auxiliary elastic members 8a are interposed between the top sheet 2 and the back sheet 3 and joined to their respective inward surfaces of the sheets by means of adhesives (not shown). The second auxiliary elastic members 8b are interposed between the top sheet 2 and the back

- 15 -

sheet 3 and joined to the inward surface of the back sheet 3 by mean of adhesives (not shown).

In each of the side edges 1b of the diaper 1A, the side portion of the top sheet 2 is positioned between a side portion 3b of the back sheet 3 and a side portion 5d of the cuff 5 and secured to those portions 3b, 5d, as shown in Figure 5. The side portions 3b, 5d are secured to each other where they overlap. When the elastic member 10 contracts, the free edge 5b of the cuff 5 is caused to upside from the top sheet 2 to form a barrier against leakage of excrements. The leg elastic members 7 are positioned between the side portion 3b of the back sheet 3 and the side portion 5d of the cuff 5 and secured to those side portions 3b, 5d by means of adhesives (not shown).

Figure 6 is a partially cut-away perspective view of a diaper 1B in accordance with another exemplary embodiment. Figure 7 is a partially cut-away plan view of the diaper 1B when its front and rear waist-encircling regions R1, R3 are disconnected from each other and developed in a longitudinal direction. Figure 8 is similar to Figure 7 but viewed from a side of the top sheet 2. In Figure 6, a waist-encircling direction and a leg-encircling direction are indicated by the arrows X and Y, respectively. In Figures 7 and 8, a lateral direction and a longitudinal direction are indicated by the



- 16 -

arrows X and Y, respectively.

The diaper 1B shown in Figure 6 differs from the diaper shown in Figure 1 in the following respects. In the diaper 1B, a liquid impervious back sheet 3 is in advance formed into a pull-on type, and a liquid-absorbing core 4 covered with a liquid pervious top sheet 2 and a water-impervious film 13 is secured to an inner surface of the back sheet 3. The core 4 is enclosed entirely by and joined to a tissue paper (not shown). The core is joined via the tissue paper to the inner surfaces of the top sheet 2 and the water-impervious film 13.

As shown in Figure 7, the diaper 1B has opposite end edges 1a and opposite side edges 1b. Each of the side edges 1b in the crotch region R2 shows a curved line toward a laterally inward direction of the diaper 1B. In each of the front and rear waist-encircling regions R1 and R3, a plurality of auxiliary elastic members 8 extending laterally and spaced longitudinally from each other by a pre-determined distance are secured in an extended state in a region between the waist elastic members 6 and the leg elastic members 7. The auxiliary elastic members 8 include plural lines of first auxiliary elastic members 8a and plural lines of second auxiliary elastic members 8b.

As shown in Figure 6, the first auxiliary elastic members

- 17 -

8a are spaced longitudinally from each other by a pre-determined distance and extend in a waist-encircling direction in the first elasticized zone E1. The second auxiliary elastic members 8b are spaced longitudinally from each other by a pre-determined distance and extend in a waist-encircling direction in the second elasticized zone E2. The number of the first auxiliary elastic members 8a is larger than that of the second auxiliary elastic members 8b. The first and second auxiliary elastic members 8a and 8b are related to each other on tensile stress as first auxiliary elastic member 8a  $\leq$  second auxiliary elastic member 8b.

In the diaper 1B, the number of the first auxiliary elastic members 8a is larger than that of the second auxiliary elastic members 8b. Accordingly, even in the case where the tensile stress of the first auxiliary elastic member 8a is comparable to that of the second auxiliary elastic member 8b, the first elasticized zone E1 shows a higher tensile stress compared to the second elasticized zone E2.

In the diaper 1B, a tensile stress for the first elasticized zone E1 when extended to its maximum extent shows a tensile stress in a range of 0.2 - 2.0 N/25 mm, preferably in a range of 0.4 - 1.0 N/25 mm, and that for the second elasticized zone E2 when extended to its maximum extent shows

- 18 -

an tensile stress in a range of 0.1 - 0.6 N/25 mm. The tensile stresses of those elasticized zones E1 and E2 are measured according to the same procedure as applied to the diaper 1A shown in Figure 1.

5           The diaper 1B when worn tightnes a wearer's waist more strongly in the first elasticized zone E1 than in the second elasticized zone E2. However, the first and second elasticized zones E1 and E2 act in concert with each other to hold the diaper 1B around the wearer's waist and prevent the diaper 1B from  
10 sliding down from its position. This allows the tensile stress of the first elasticized zone E1 to be within the above-specified range.

          In the second elasticized zone E2 of the diaper 1B, the core 4 is pressed against the wearer's skin by the tensile stress  
15 of the second auxiliary elastic members 8b so that its excrement-absorbing function is not adversely affected. Since the tensile stress of the second elasticized zone E2 in the diaper 1B is maintained within the above-specified range, the core 4 due to its rigidity withstands the force exerted by the  
20 contraction of the second elasticized zone E2 and wrinkles will not be formed on the core 4.

          Figures 9 and 10 are end views taken along the line D-D and the line E-E of Figure 5, respectively. Figure 11 is an



- 19 -

end view taken along the line F-F of Figure 5. The back sheet 3 comprises two mutually overlaid hydrophobic non-woven fabrics 3c and 3d with their opposing surfaces of 3c, 3d joined intermittently. The back sheet 3 may comprise a composite sheet 5 made by laminating a hydrophobic non-woven fabric and a plastic film.

Waist elastic members 6, first and second leg elastic members 7a and 7b, and first and second auxiliary elastic members 8a and 8b are all positioned between the non-woven fabrics 3c and 3d constituting the back sheet 3 and secured to those non-woven fabrics 3c, 3d by adhesives (not shown).

In the diaper 1B, a side portion 2b of the top sheet 2 and a side portion 13b of a water-impervious film 13 extend outwardly from each side edge 4b of the core 4, as shown in Figure 11. The film side portion 13b is folded upwardly from each side edge 4b of the core 4 to overlay an outside surface of the top sheet 2. The fixed edge 5a of the leakage-resistant cuff 5 located between and secured to the side portions 2b and 13b. The fixed ends 5c of the cuff 5 are both secured to the outside surface of the top sheet 2. The free edge 5b of the cuff 5 uprises from the top sheet 2 by the contraction of the elastic member 10.

Non-woven fabrics of hydrophilic fibers and porous

- 20 -

plastic films with a large number of micro-pores can be used for the top sheet 2. Non-woven fabrics of hydrophilic fibers, liquid impervious plastic films and laminate sheets comprised of a hydrophilic non-woven fabric and a liquid impervious plastic film can be used for the back sheet 3 of the diaper 1A shown in Figure 1. Non-woven fabrics of hydrophilic fibers can be used for the leakage-resistance cuff 5. Flexible plastic films can be used for the water-impervious film 13.

A composite non-woven fabric with a highly water-resistant non-woven fabric made by melt-blown process disposed between high-strength and highly flexible spun-bonded non-woven fabrics can also be used for the back sheet 3, 3c, 3d and the cuff 5 of the diaper 1A, 1B shown as embodiments.

Useful non-woven fabrics can be manufactured by various techniques including spun-lacing, needle punching, melt blown, thermal bonding, spun-bonding, chemical bonding, air-through and other processes. Examples of useful fibers constituting such non-woven fabrics include fibers such as of polyolefin, polyester and polyamide, sheath-core and side-by-side conjugate fibers such as of polyethylene/polypropylene or polyester.

The elastic members 6, 7, 8 and 10 are elastomers comprising a natural or synthetic rubber. In the shown diapers

- 21 -

1A, 1B, the elastic members 6, 7, 8 and 10 take the form of strands. However, the elastic members 6, 7, 8 and 10 may take a form of bands.

In the diaper 1A and 1B shown as embodiments, the elastic members 6, 7, 8 and 10 may be secured, either in an intermittent or continuous manner, to the top and back sheets 2, 3, 3c, 3d and the cuff 5 by means of adhesives. Also in the diaper 1A and 1B shown as embodiments, the waist elastic members 6 and the auxiliary elastic members 8 may be attached to at least one of the front and rear waist-encircling regions R1 and R3.

The core 4 comprises a mixture of fluff pulps, high-absorbent polymer particles and thermoplastic synthetic fibers and is provided in the form of being compressed to a predetermined thickness. Accordingly, the core 4 exhibits higher rigidity compared to the top and back sheets 2, 3, 3c, 3d and the cuff 5. Examples of useful high-absorbent polymers include starch-, cellulose- and synthetic polymer-based polymers.

Hot-melt adhesives or welding means such as sonic sealing or heat sealing can be utilized to secure the top sheet 2 to the back sheet 3, 3c, 3d, secure the leakage-resistant cuff 5 and water-impervious film 13, and join the core 4.

The disposable pull-on garment in the present invention, when worn, tightens a wearer's waist by tensile stress of the



- 22 -

first and second elasticized zones so that the garment while worn can be prevented from sliding down from its position. In the garment in which the first and second auxiliary elastic members are related to each other on tensile stress as the first  
5 auxiliary elastic member  $>$  the second auxiliary elastic member and the first and second elasticized zones are related to each other on tensile stress as the first elasticized zone  $>$  second elasticized zone, the first elasticized zone tightens a wearer's waist more strongly than the second elasticized zone.  
10 However, the first elasticized zone is not the only one that acts on the wearer but acts in concert with the second elasticized zone to tighten the wearer's waist. Hence, the tensile stress of the first elasticized zone in this garment is not required to be increased to such level as required in  
15 the prior art garment construction. As a result, such a situation as the first elasticized zone exerts a strong pressure on the wearer's waist can be avoided.

In the garment in which the first and second auxiliary elastic members are related to each other on tensile stress as  
20 first auxiliary elastic member  $\geq$  second auxiliary elastic member and the number of the first auxiliary elastic members is larger than that of the second auxiliary elastic member, the first elasticized zone exhibits a higher tensile stress than

- 23 -

the second elasticized zone and tightens the wearer's waist more strongly than the second elasticized zone. However, the first elasticized zone is not the only one that acts on the wearer but acts in concert with the second elasticized zone to tighten  
5 the wearer's waist. Hence, the tensile stress of the first elasticized zone in this garment is not required to be increased to such a level as required for the prior art garment construction. As a result, such a situation as the first elasticized zone exerts a strong pressure on the wearer's waist  
10 can be avoided.

Also in such garments, the core is pressed against the wearer's skin by the tensile stress of the second auxiliary elastic members so that it is prevented from being spaced away from the wearer's skin. As a result, such a situation as the  
15 excrement-absorbing function of the core is not adversely affected can be avoided. Also in accordance with these garments, the core due to its rigidity withstands the force exerted by the contraction of the second elasticized zone E2 and wrinkles will not be formed on the core. As a result, such a situation  
20 as the core is spaced away from the wearer's skin can be avoided.

- 24 -

## WHAT IS CLAIMED IS:

1. A disposable pull-on garment which comprises a liquid pervious top sheet, a liquid impervious back sheet and an liquid  
5 absorbent core interposed between those sheets and includes front and rear waist-encircling regions opposed to each other, a crotch region positioned between the front and rear waist-encircling regions, and a waist-encircling opening and a pair of leg-encircling openings defined by joining respective  
10 longitudinal sides edges of the front and rear waist-encircling regions, and in which the waist-encircling elastic members are attached in an extended state to an edge of the waist-encircling opening in at least one of the front and rear waist-encircling regions, and plural lines of auxiliary elastic members spaced  
15 longitudinally from each other by a pre-determined distance and extending in the waist-encircling direction are attached in an extended state in a region between the waist elastic members and the leg-encircling opening edge in at least one of the front and rear waist-encircling regions;

20 said front and rear waist-encircling regions each having a first elasticized zone which extends in the waist-encircling direction from opposite longitudinal side edges of the region toward the vicinities of opposite side edges of the core, and



- 25 -

a second elasticized zone which traverses the core to extend in the waist-encircling direction between the vicinities of opposite side edges of the core; and

said auxiliary elastic members including plural lines of first auxiliary elastic members extending in the waist-encircling direction in the first elasticized zone and plural lines of second auxiliary elastic members extending in the waist-encircling direction in the second elasticized zone, a tensile stress of said first auxiliary elastic members is greater than that of the second auxiliary elastic member, and a tensile stress of said first elasticized zone being greater than that of the second elasticized zone.

2. A disposable pull-on garment which comprises a liquid pervious top sheet, a liquid impervious back sheet and an liquid absorbent core interposed between those sheets and includes front and rear waist-encircling regions opposed to each other, a crotch region positioned between the front and rear waist-encircling regions, and a waist-encircling opening and a pair of leg-encircling openings defined by joining respective longitudinal sides edges of the front and rear waist-encircling regions, and in which the waist-encircling elastic members are attached in an extended state to an edge of the waist-encircling

- 26 -

opening in at least one of the front and rear waist-encircling regions, and plural lines of auxiliary elastic members spaced longitudinally from each other by a pre-determined distance and extending in the waist-encircling direction are attached in an  
5 extended state in a region between the waist elastic members and the leg-encircling opening edge in at least one of the front and rear waist-encircling regions;

said front and rear waist-encircling regions each having a first elasticized zone which extends in the waist-encircling  
10 direction from opposite longitudinal side edges of the region toward the vicinities of opposite side edges of the core, and a second elasticized zone which traverses the core to extend in the waist-encircling direction between the vicinities of opposite side edges of the core; and

15 said auxiliary elastic members including plural lines of first auxiliary elastic members extending in the waist-encircling direction in the first elasticized zone and plural lines of second auxiliary elastic members extending in the waist-encircling direction in the second elasticized zone, said  
20 first and second auxiliary elastic members being related to each other on tensile stress as first auxiliary elastic member second auxiliary elastic member, and the number of said first auxiliary elastic members being larger than that of said second

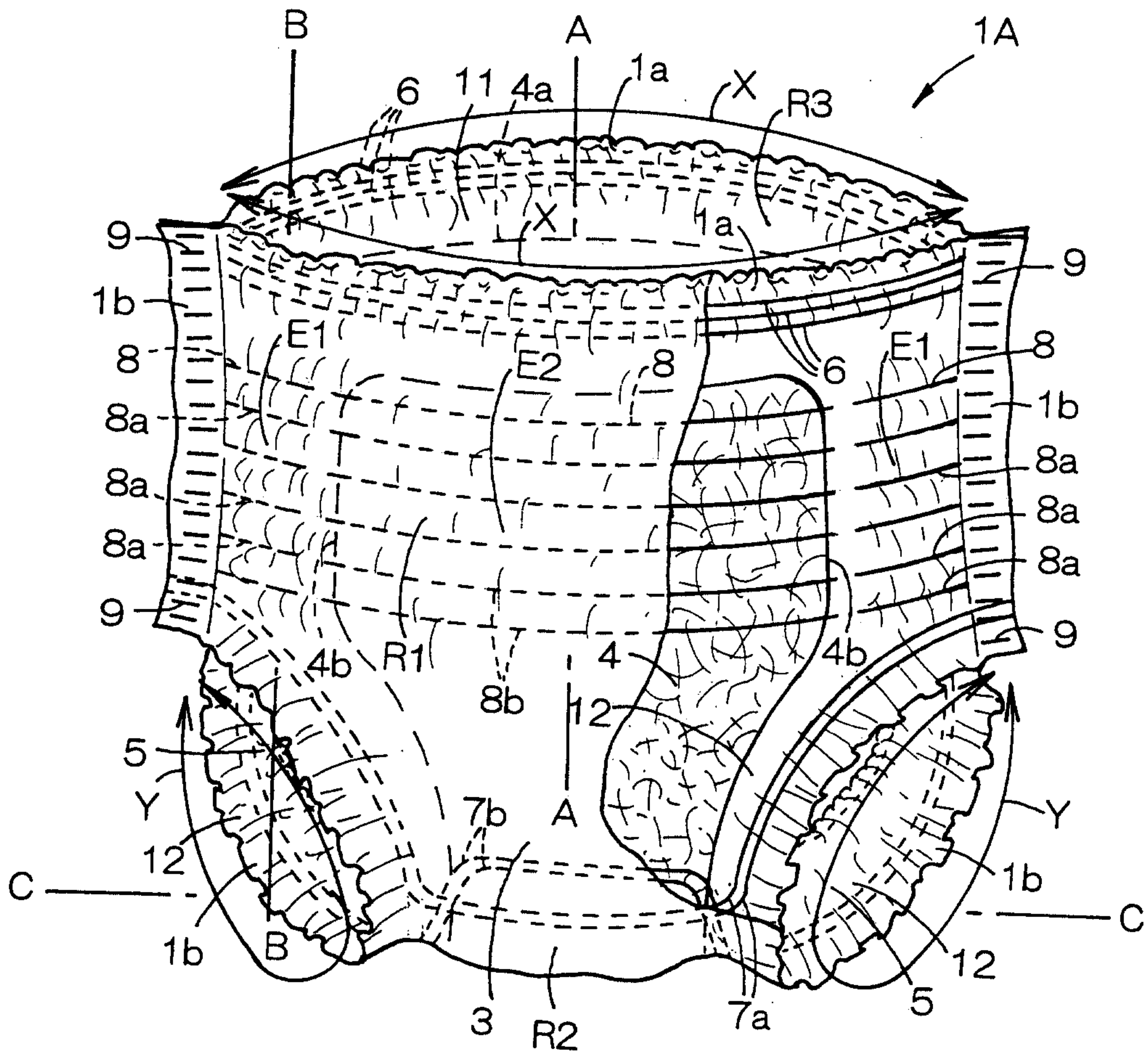
- 27 -

auxiliary elastic members.

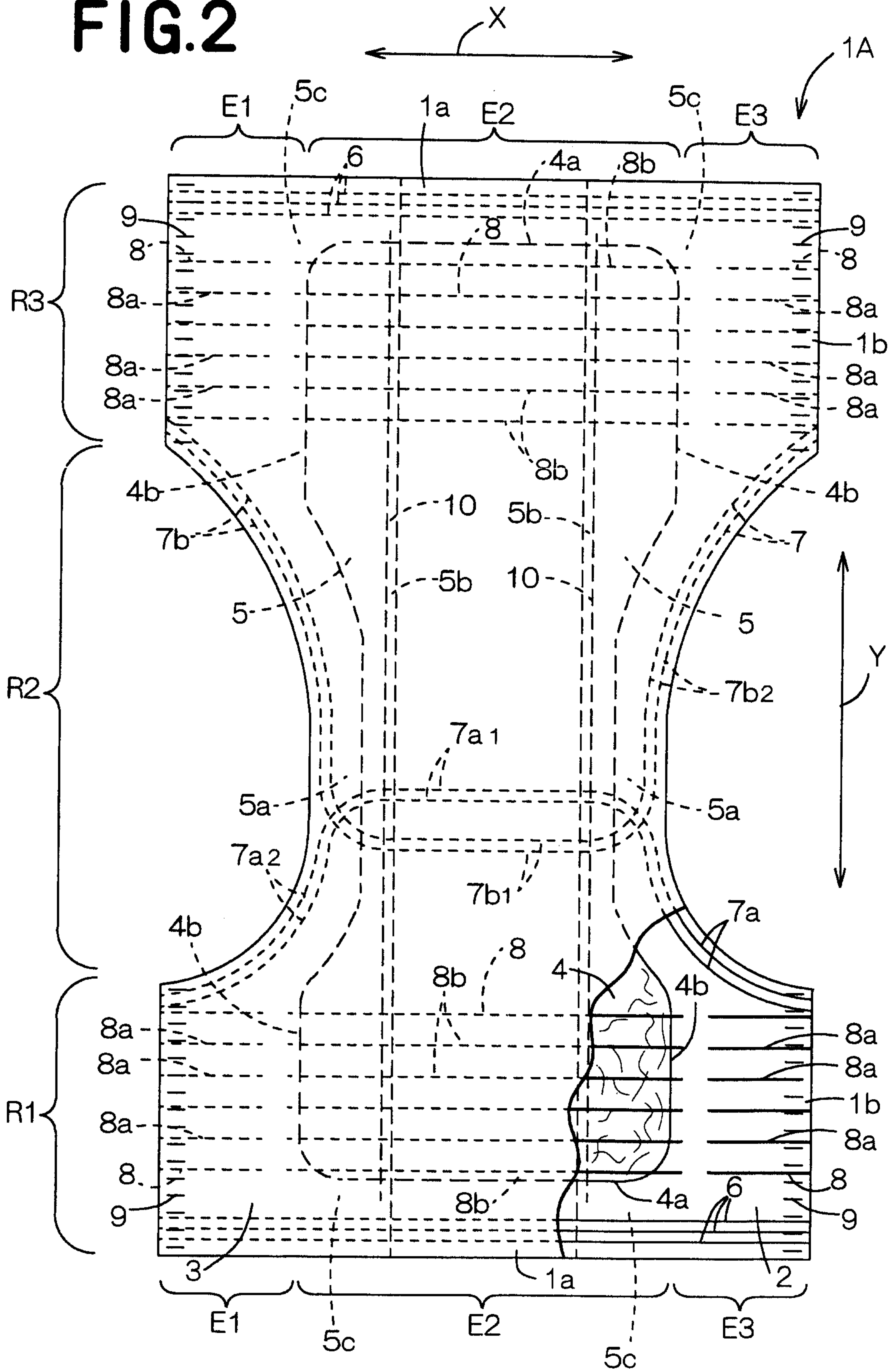
3. The garment of Claim 1, wherein said first elasticized zone when extended to a maximum extent shows a tensile stress  
5 in a range of 0.2 - 2.0 N/25 mm and said second elasticized zone when extended to a maximum extent shows a tensile stress in a range of 0.1 - 0.6 N/25 mm.



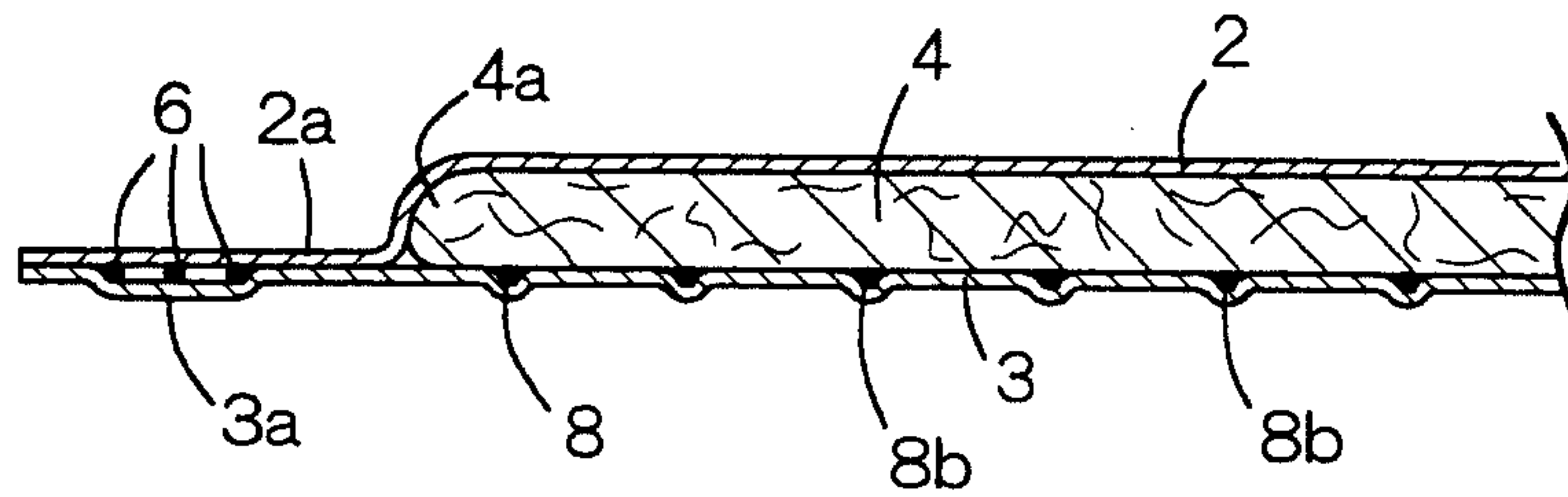
# FIG. 1



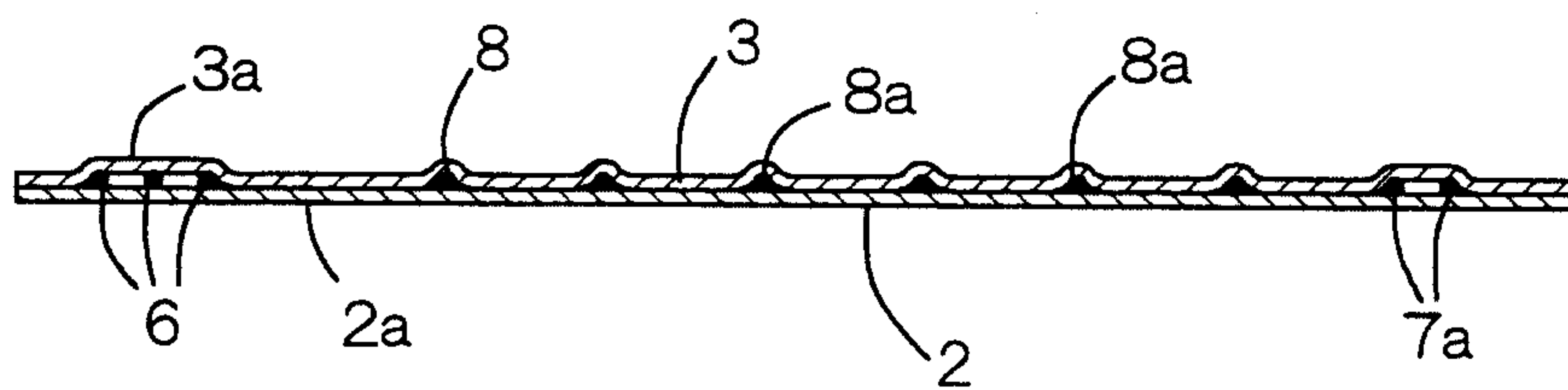
**FIG.2**



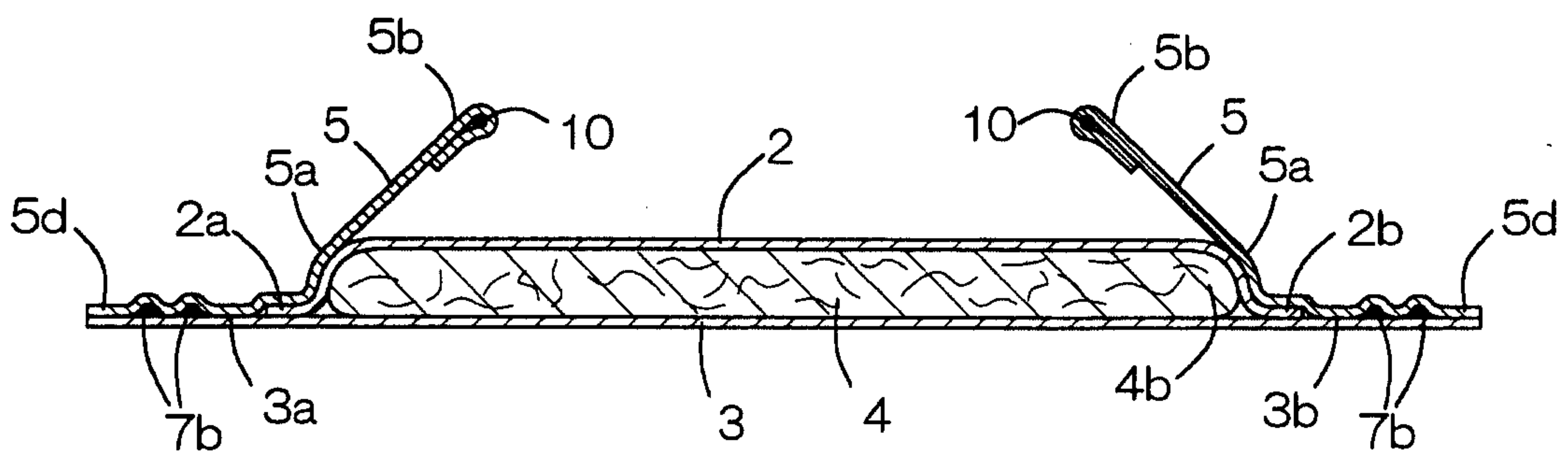
**FIG.3**



**FIG.4**

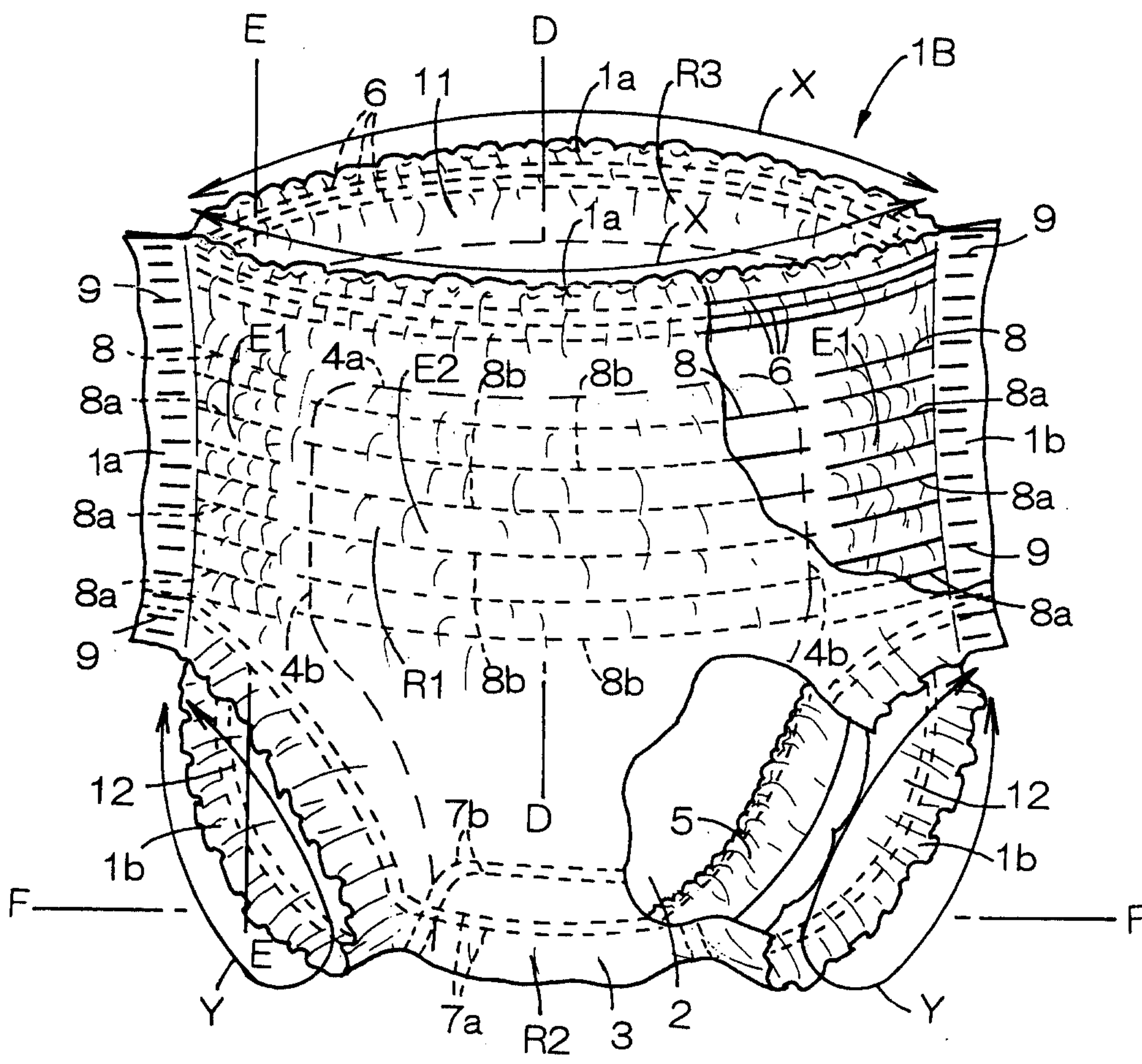


**FIG.5**

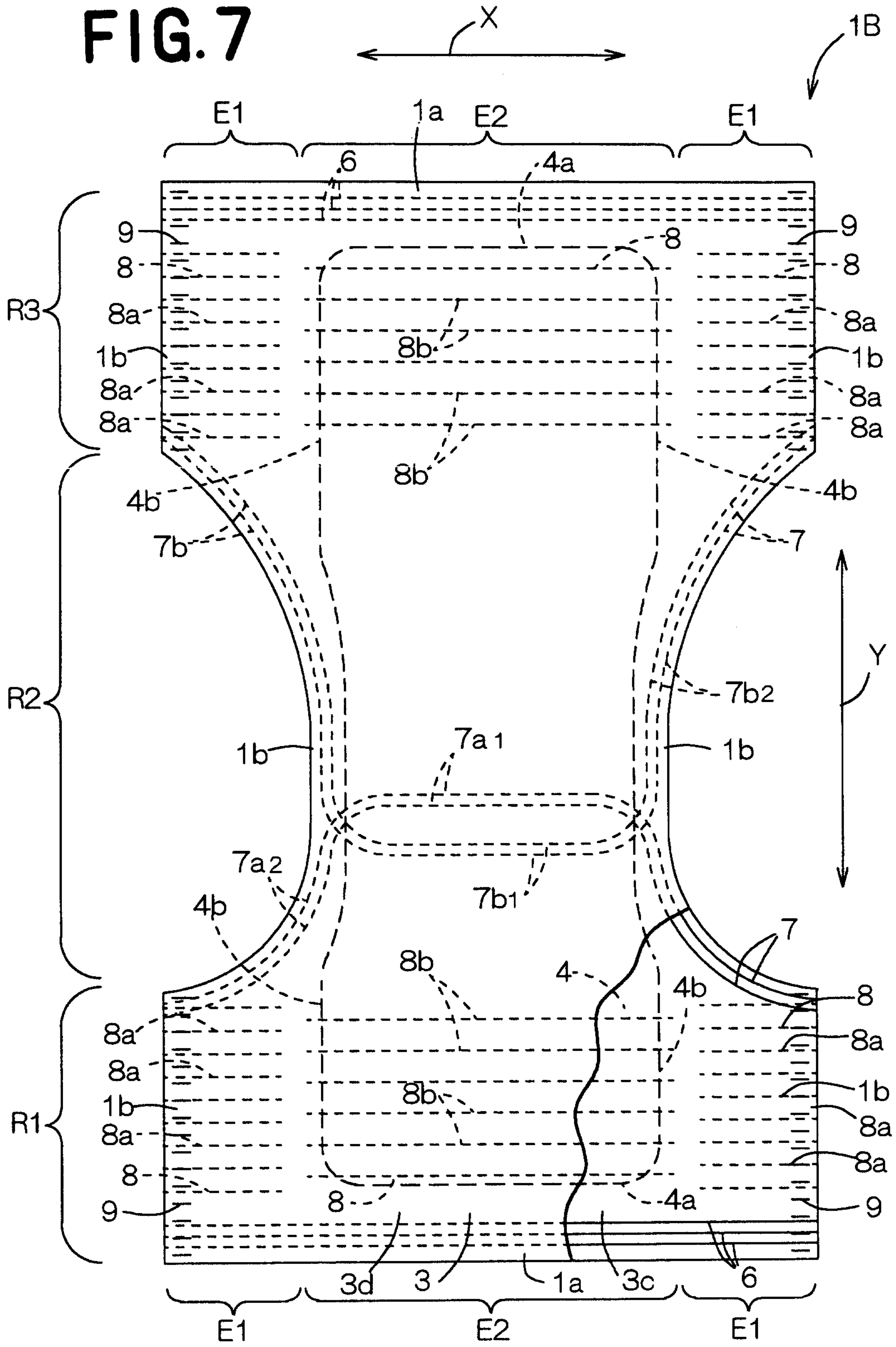




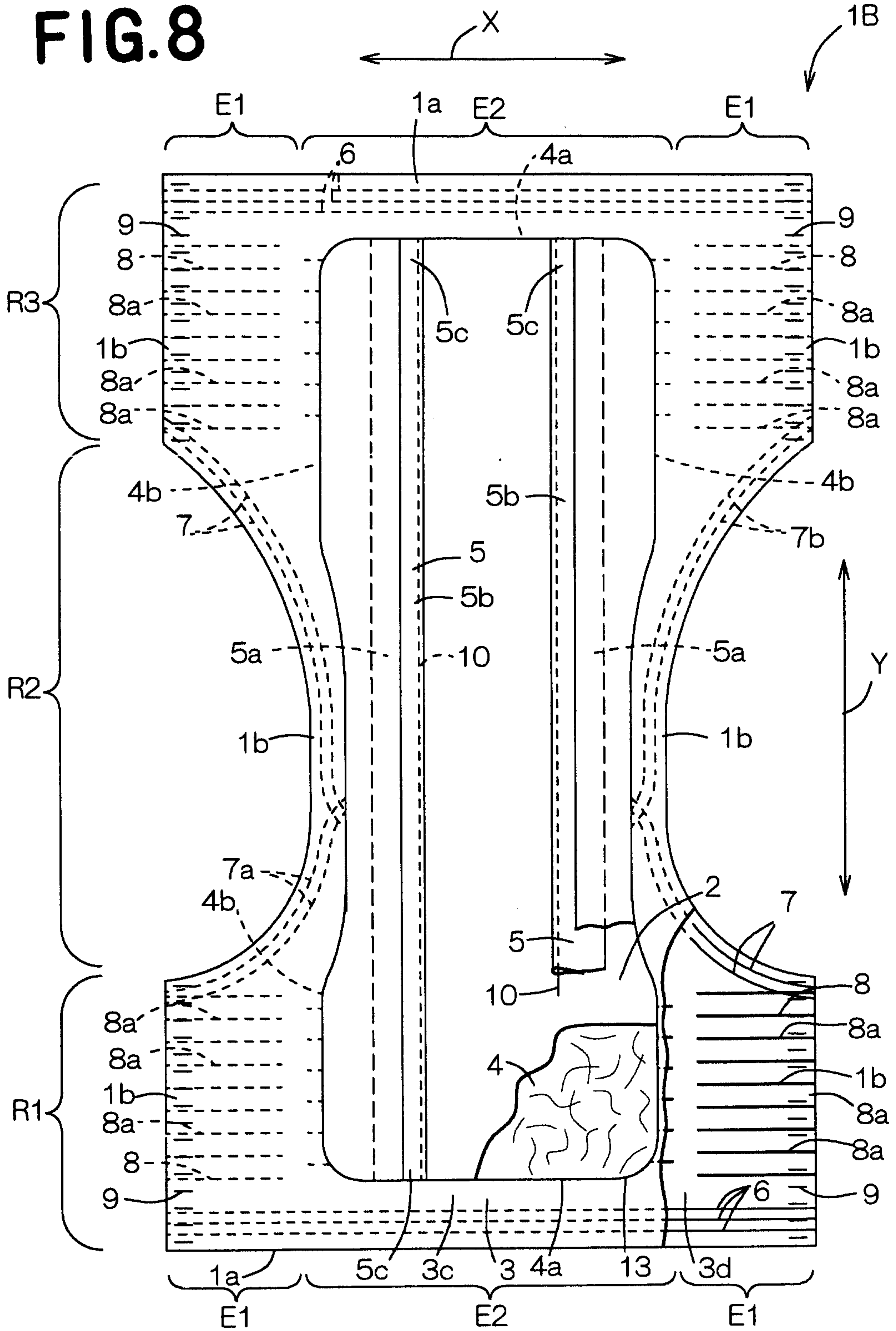
# FIG.6



**FIG. 7**

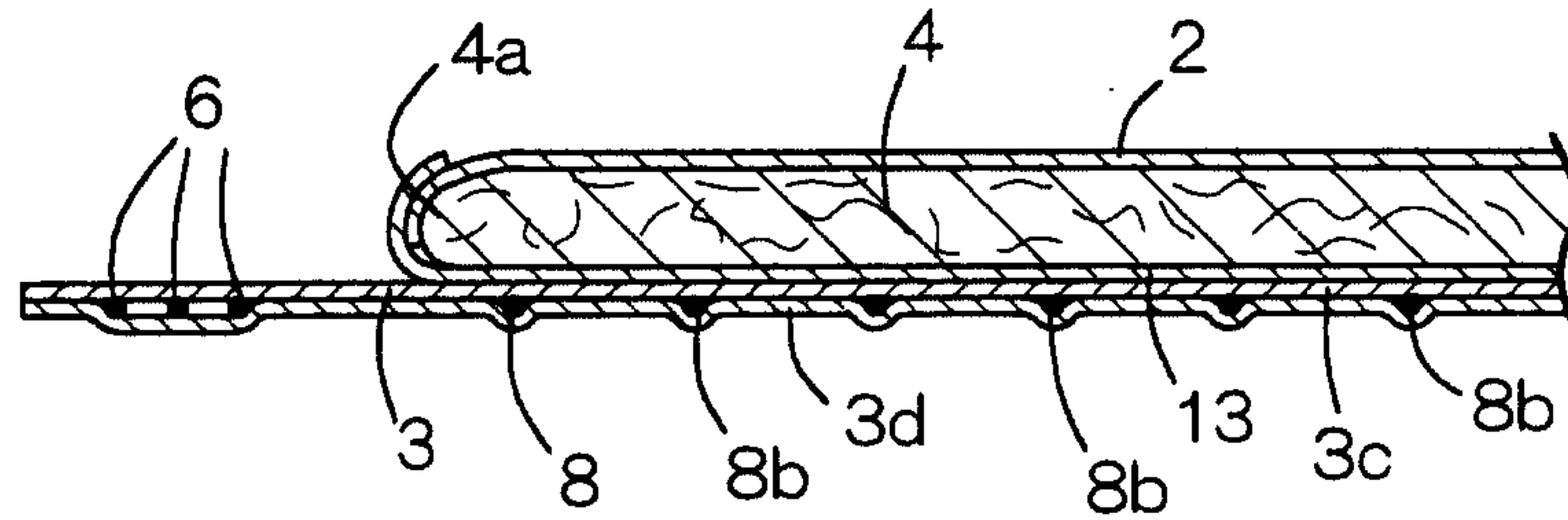


**FIG. 8**

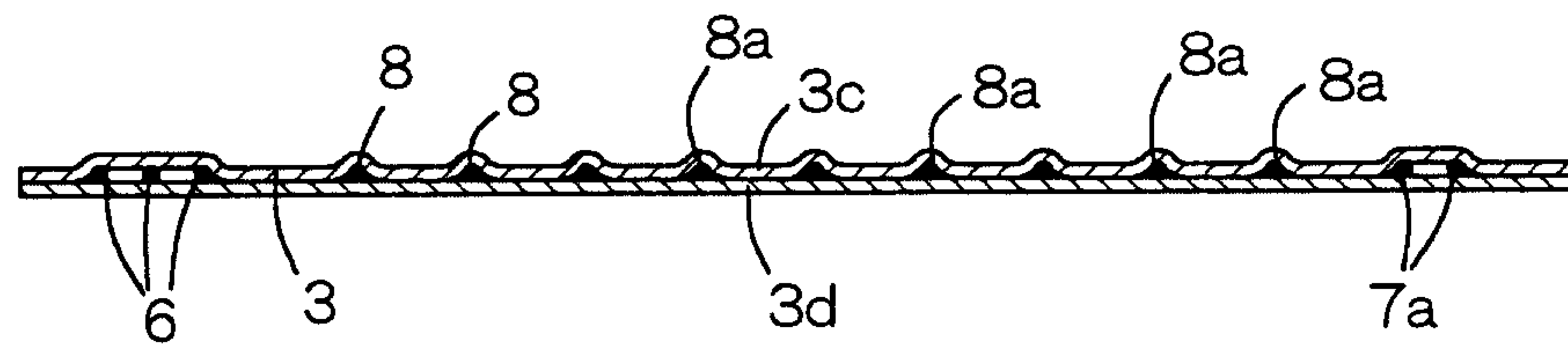




# FIG. 9



# FIG. 10



# FIG. 11

