

(No Model.)

2 Sheets—Sheet 1.

J. GOOCH.
SHOP FRONT.

No. 381,361.

Patented Apr. 17, 1888.

FIG. 1.

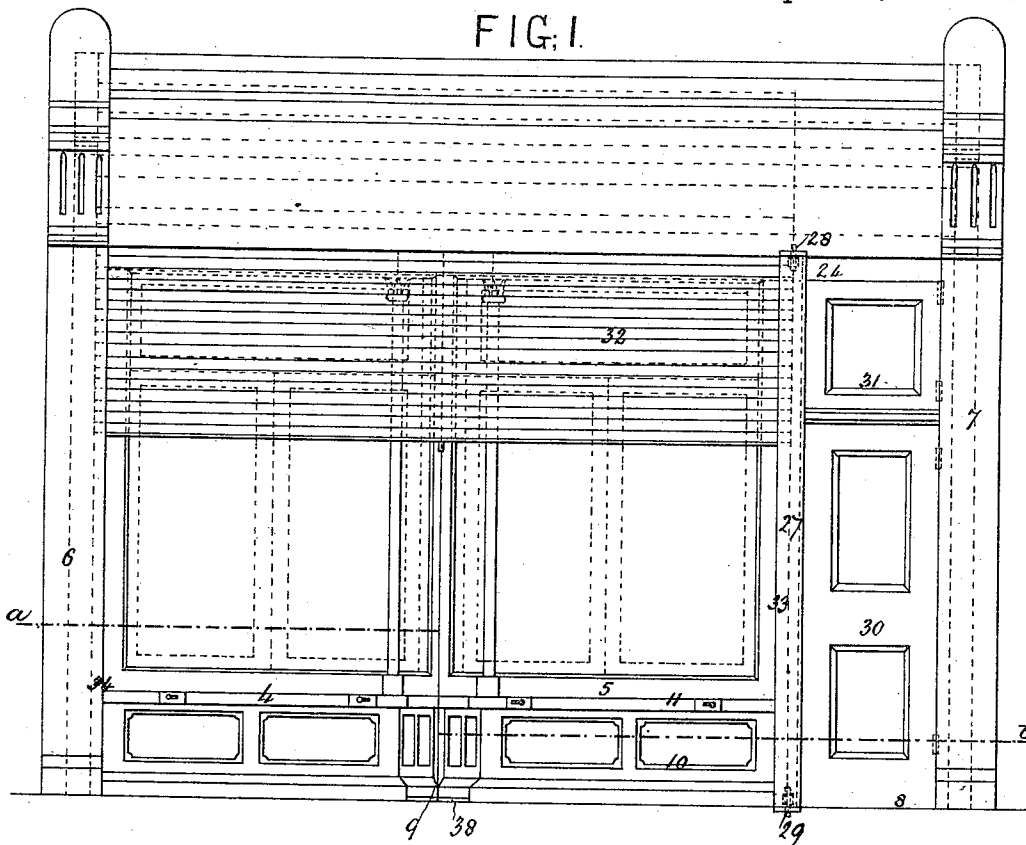
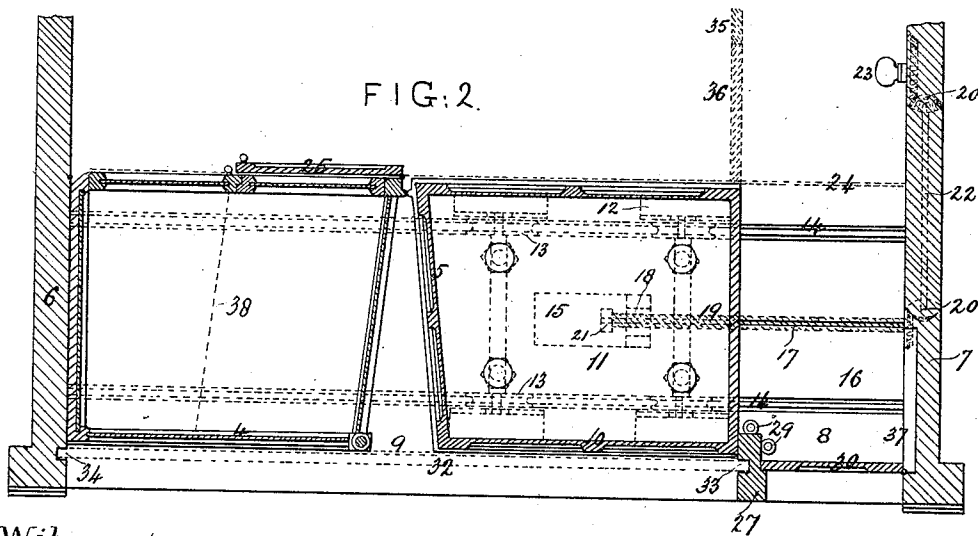

FIG. 2.



Witnesses:
 William D. Bonner,
 Jno. E. Power.

Inventor
 John Gooch
 by his Attorneys
 Horson and Co.

J. GOOCH.
SHOP FRONT.

No. 381,361.

Patented Apr. 17, 1888.

FIG. 4.

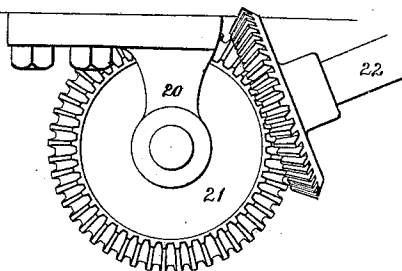

FIG. 3.

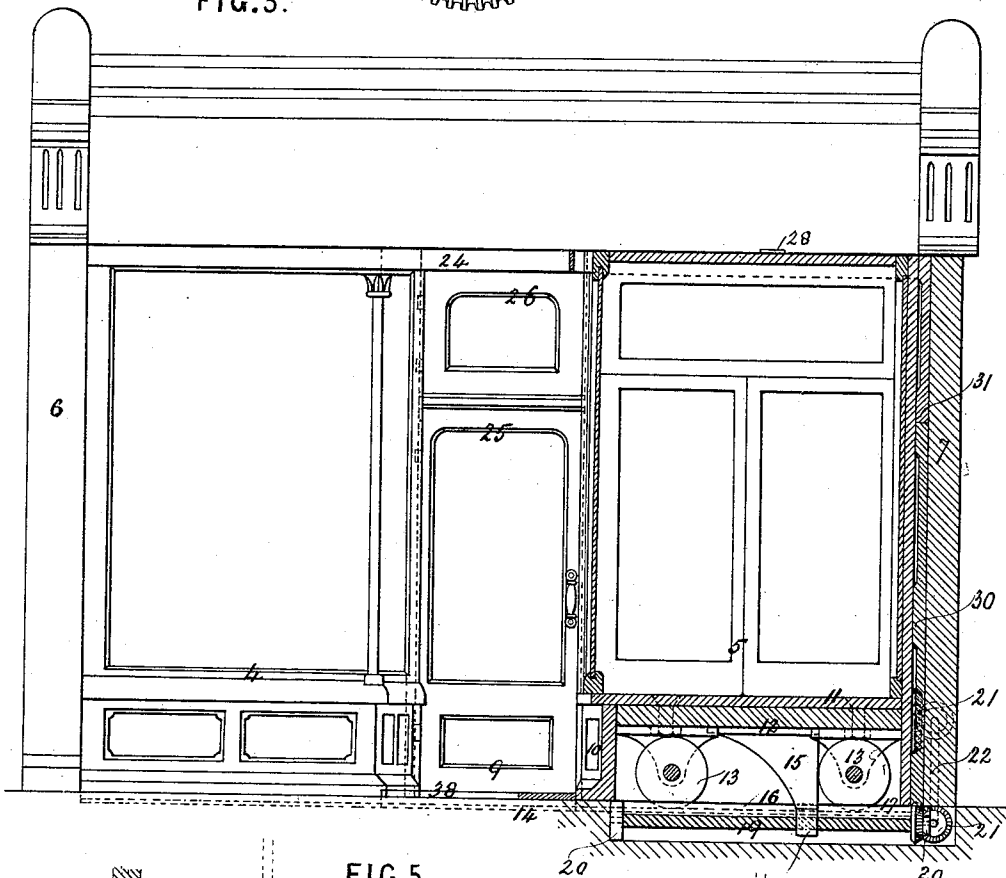
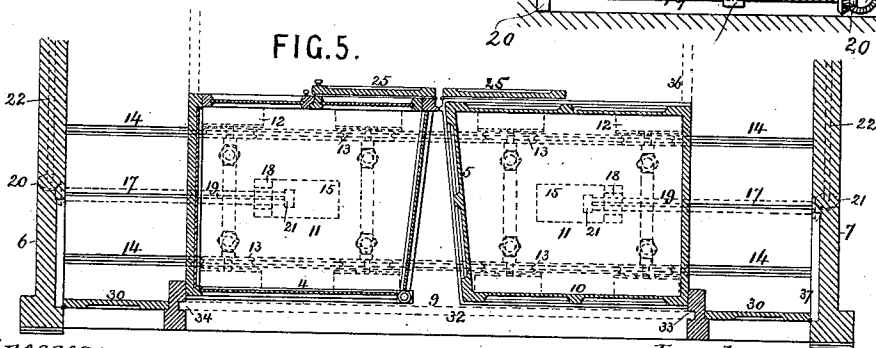

FIG. 5.



Witnesses:
William D. Bonner,
Jno E. Parker

Inventor:
John Gooch,
by his Attorneys,
Howson and Co

UNITED STATES PATENT OFFICE.

JOHN GOOCH, OF BROMPTON ROAD, COUNTY OF MIDDLESEX, ENGLAND.

SHOP-FRONT.

SPECIFICATION forming part of Letters Patent No. 381,361, dated April 17, 1888.

Application filed April 1, 1887. Serial No. 233,276. (No model.) Patented in England March 14, 1887, No. 3,850; in France March 23, 1887, No. 182,396; in Belgium March 23, 1887, No. 76,825; in Norway March 29, 1887, No. 501; in Germany March 29, 1887, No. 41,009; in Sweden March 31, 1887, No. 1,028; in Canada April 12, 1887, No. 26,433; in Italy April 21, 1887, No. 21,437; in Victoria April 29, 1887, No. 5,045; in Tasmania May 7, 1887, No. 463/9; in New Zealand May 16, 1887, No. 2,339; in South Australia May 23, 1887, No. 812; in Spain June 18, 1887, No. 6,842; in New South Wales July 30, 1887, No. 2,118; in Austria-Hungary August 27, 1887, No. 12,350 and No. 34,839; in Queensland 1887, No. 293, and in India December 23, 1887, No. 2221.

To all whom it may concern:

Be it known that I, JOHN GOOCH, a subject of the Queen of Great Britain and Ireland, and a resident of Brompton Road, county of Middlesex, England, outfitter, have invented certain Improvements in Shop-Fronts, (for which I have obtained patents in Great Britain, No. 3,850, dated March 14, 1887; in France, No. 182,396, dated March 23, 1887; in Belgium, No. 76,825, dated March 23, 1887; in Norway, No. 501, dated March 29, 1887; in Germany, No. 41,009, dated March 29, 1887; in Sweden, No. 1,028, dated March 31, 1887; in Canada, No. 26,433, dated April 12, 1887; in Italy, No. 21,437, dated April 21, 1887; in Victoria, No. 5,045, dated April 29, 1887; in Tasmania, No. 463/9, dated May 7, 1887; in New Zealand, No. 2,339, dated May 16, 1887; in South Australia, No. 812, dated May 23, 1887; in Spain, No. 6,842, dated June 18, 1887; in New South Wales, by letters of registration No. 2,118, dated July 30, 1887; in Austria-Hungary, No. 12,350 and No. 34,839, dated August 27, 1887; in Queensland, No. 293, dated 1887, and in India, No. 2221, dated December 23, 1887,) of which the following is a specification.

The object of this invention, which relates to improvements in shop-fronts, is to provide in an improved manner facilities and means whereby the whole extent of the frontage between the side or party walls can during business hours be rendered available and used for the display of goods and for business purposes, and whereby when not required for such purposes the shop or like place of business can be closed, while at the same time and by the same provision and means access to the house or residential part of the premises through one or more private entrances separate from the shop-entrance is or are provided.

The invention consists, essentially, in the construction of the shop-front in such a manner as that a part thereof is movable or adjustable relatively to the other part, or as that parts thereof are movable or adjustable relatively to one another, so that during business hours the movable front part or parts can be

separated the one from the other or from each other, so as to open up an entrance or entrances from the front into the shop while closing up the private entrance or entrances from the front into the house, and so that after business hours the said front part or parts can be brought together, so as to close up the front entrance or entrances to the shop while opening up the front private entrance or entrances into the house.

On the accompanying drawings, Figure 1 represents a front elevation of a shop-frontage constructed in accordance with the present invention, showing the shop or place of business closed up, while access is provided to the residential part of the premises. Fig. 2 represents a sectional plan view thereof through the line *a b*. Fig. 3 represents a like view to Fig. 1, but partly in section, showing the front entrance to the house closed and the front entrance to the shop opened, the whole width of the frontage being thus rendered available for the display of goods and for business purposes. Fig. 4 is a detached view of the bearing 20, and Fig. 5 is a sectional plan view of a modification.

In carrying out the invention the shop-front is constructed in parts, one, both, any, or all of which (depending principally upon the construction of the premises and the number of entrances required into the shop and into the house, respectively) is or are adapted or provided with means of supporting and moving or adjusting the same in the direction of the length of the frontage from or toward the other part or parts of the front.

On the annexed drawings the shop-front is represented as made in two parts, 45, the former of which is constructed in any ordinary manner, and occupies a fixed position in relation to its adjacent side wall, 6, while the part 5 is constructed and adapted in accordance with the present improvements—that is, in such a manner as to be capable of being readily moved or adjusted from a position adjacent to its side wall, 7, in which position it closes the front private entrance, 8, to the house and permits

of entrance to the shop from the front through the doorway 9 (*vide* Fig. 3) to a position adjacent to the fixed front 4, in which it closes the shop-entrance 9 and permits of entrance to the house through the private doorway 8. (*Vide* Figs. 1 and 2.)

In order that the movements of the movable part or parts of the front may be steadily effected without liability of disarranging the contained goods and without necessitating that such part should be "undressed," its base 10 is made of a rigid box-like construction, and is constructed with a strong flooring, 11, which is adapted to rest upon and is bolted or otherwise suitably secured to a supporting framework or carriage, 12, which is mounted upon suitable traveling wheels, 13, which run along and are guided by rails 14, let into the flooring. The carriage 12 and the said connected structure 5 (which it supports just clear of the flooring) may be caused to receive the desired movements along the rails 14 and between top guides, 24, by hand; but in order to obtain steadiness and regularity of movement it is preferable that the movement should be imparted by mechanical means. Suitable means for attaining this object consist of a depending extension or extensions, 15, bolted or otherwise secured to the under side of the carriage 12 and extending below the flooring 16, passing through an opening, 17, formed therein in the direction of the movement of the carriage. The extremity 18 of each extension 15, below the level of the flooring, is formed to engage with a screwed rod, 19, which is mounted in suitable bearings, 20, Fig. 4, and extends parallel with and under the said opening 17, for the necessary longitudinal extent, and can be rotated in both directions by means of bevel-gearing 21 and a connecting-shaft, 22, which can be conveniently operated by means of a handle, 23.

If it should be required to actuate both parts 4 5 of the front away from and toward each other, so as to provide for a wide shop-entrance, 9, and for a private entrance, 8, adjacent to each side wall, then both such parts 4 5 may be likewise fitted to or with supporting and guiding carriages, as shown in Fig. 5, and they may be independently operated by different connections, 15 to 23, or they may both be simultaneously operated from the same screwed rod, 19, by extending it as far as necessary, and by forming the screwed parts which would actuate the parts 4 5 respectively right and left handed.

If the shop-entrance 9 is closed by a door, 25, and fan-light 26, fitting behind the parts 4 5, then all that is necessary to do to close up the shop and afford access to the house-entrance 8 is to appropriately operate the actuating mechanism by turning the handle 23, so as to cause the part or parts 4 5 of the front to be moved toward each other as required. If, however, the said shop-entrance 9 is closed by a door, 25, and fan-light 26, fitting between the parts 4 5, then such door 25 and fan-light 26

would require to be opened before the said actuating mechanism was operated.

When the parts assume the position in which the shop is closed, (*vide* Figs. 1 and 2,) they are retained in such position by uprights 27, which can be at once placed and bolted on the inside in position to the *facia* at 28 and flooring at 29, such uprights acting as door-posts, between which and the adjacent wall the door 30 and fan-light 31 can then be closed in a usual manner. Such door 30 and fan-light 31 may be removable from their hinges, or may be turned back into suitable recesses, 37, formed in the inner surface of the adjacent wall, so that the movable front part or parts may be moved quite up to the wall or walls when the shop is opened.

When the shop-front is desired to be fitted with revolving shutters 32, the said upright 27 can also be made to act as a means of guiding one side of the shutter, its adjacent side being grooved, as at 33, the other side of the shutter being likewise guided, or being guided by a groove, 34, in the side wall, 6, so that the shop-front may be thus protected, if required, the private entrance or entrances being only protected by doors secured in a usual manner, so as to permit of all proper access thereto.

It will be understood that the shop-fronts may be made of any desired ornamental or like construction, depending upon the nature of the business, this not being in any way material to the invention.

It will thus be seen that the application of the invention will be of considerable advantage in all localities where window-space is desired and of any especial value, and where the frontage is comparatively narrow and where the utmost possible frontage is required for the display of goods to be sold.

In such buildings as are formed with a staircase or side hall divided off by a wall, as dotted at 35, and by means of which staircase or hall only access can be obtained to the domestic part of the building, then, when access to such staircase or hall is closed through the front private entrance, 8, access may be obtained thereto from the shop through a separate door, 36, properly applied and secured in a usual manner.

The entrance 9 into the shop is preferably fitted with a mat, 38, to the lower side of which are attached metal strips which fit on the rails 14, and so permit of the mat being slid endwise along the rails under or from under the part 4 when it is desired to adjust the part 5.

I claim—

1. A shop-front in two parts, one movable laterally with reference to the other, substantially as and for the purpose set forth.
2. A shop-front in two parts, one mounted on wheels, and thereby movable laterally with reference to the other.
3. A shop-front in two parts, one of which is fixed and the other movable laterally, in

combination with a door to close the space between the two parts when they are separated, and a door and removable upright for the space left between the side wall of the shop and the movable part when the parts are brought together, substantially as set forth.

4. The combination of the fixed part of a shop-front and a movable part having an extension, 15, below the same, a feed screw to which the said extension is adapted below the flooring, and operative gearing for the said feed-screw, all substantially as specified.

5. The combination of the movable part of a shop-front mounted on wheels, with guiding-rails for the wheels, a guiding-rail at the top, a depending extension from the said movable part, a feed-screw adapted to the said extension, and gearing for the feed-screw.

6. The combination of the fixed and mov-

able parts of a shop-front with a movable upright adapted to fit against the said movable part when it is closed against the fixed one, and serving as a door-post, and a hinged door in connection therewith, all substantially as specified.

7. The combination of the fixed and movable parts of a shop-front with a movable upright adapted to fit the movable part of the shop-front, and having a guiding-groove, 33, for the rolling shutter, all substantially as specified.

In testimony whereof I have signed my name to this specification in the presence of two subscribing witnesses.

JOHN GOOCH.

Witnesses:

CHAS. A. DAY,
PERCY D. DAY.