

April 19, 1966

M. DIAMOND
MICROWAVE ANTENNA

3,247,512

Filed Feb. 17, 1964

2 Sheets-Sheet 1

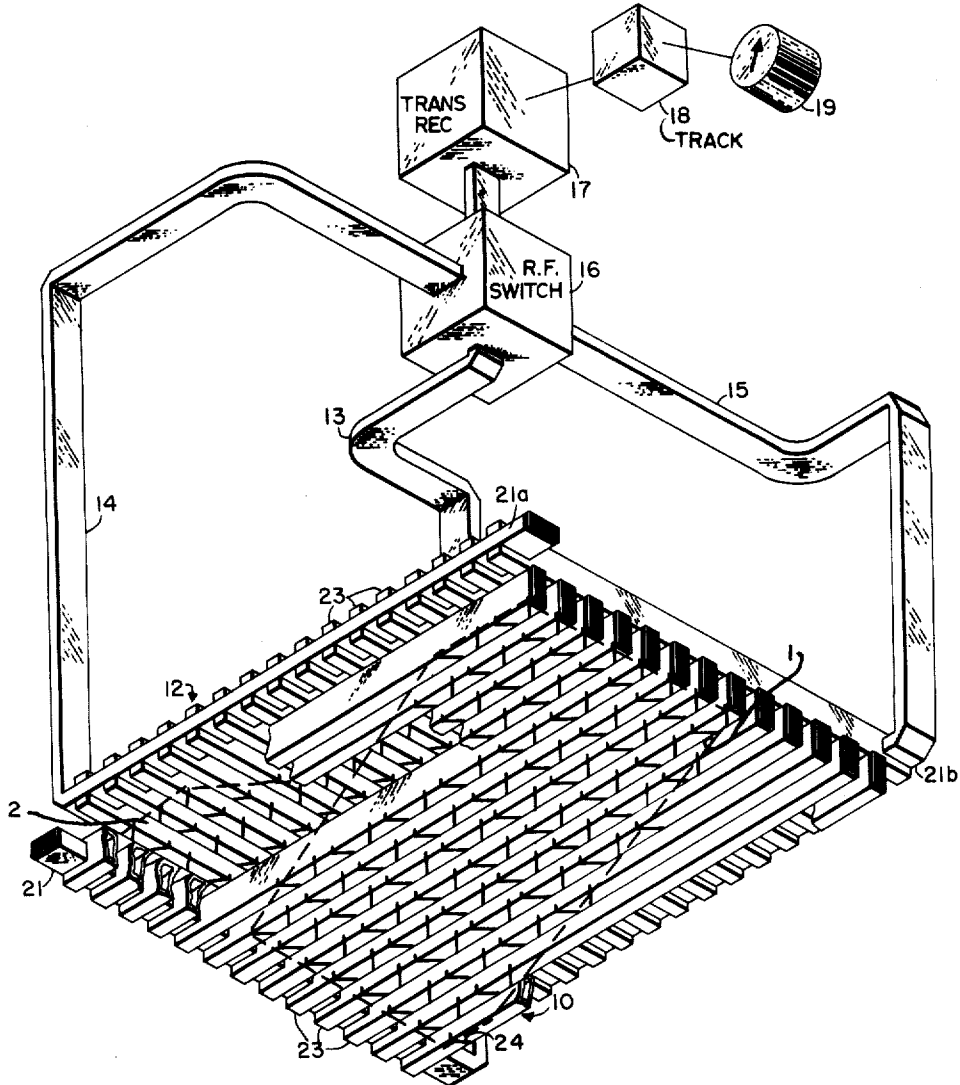

FIG. 1

INVENTOR.
MAURICE DIAMOND

BY

Philip J. McFarland
ATTORNEY

April 19, 1966

M. DIAMOND
MICROWAVE ANTENNA

3,247,512

Filed Feb. 17, 1964

2 Sheets-Sheet 2

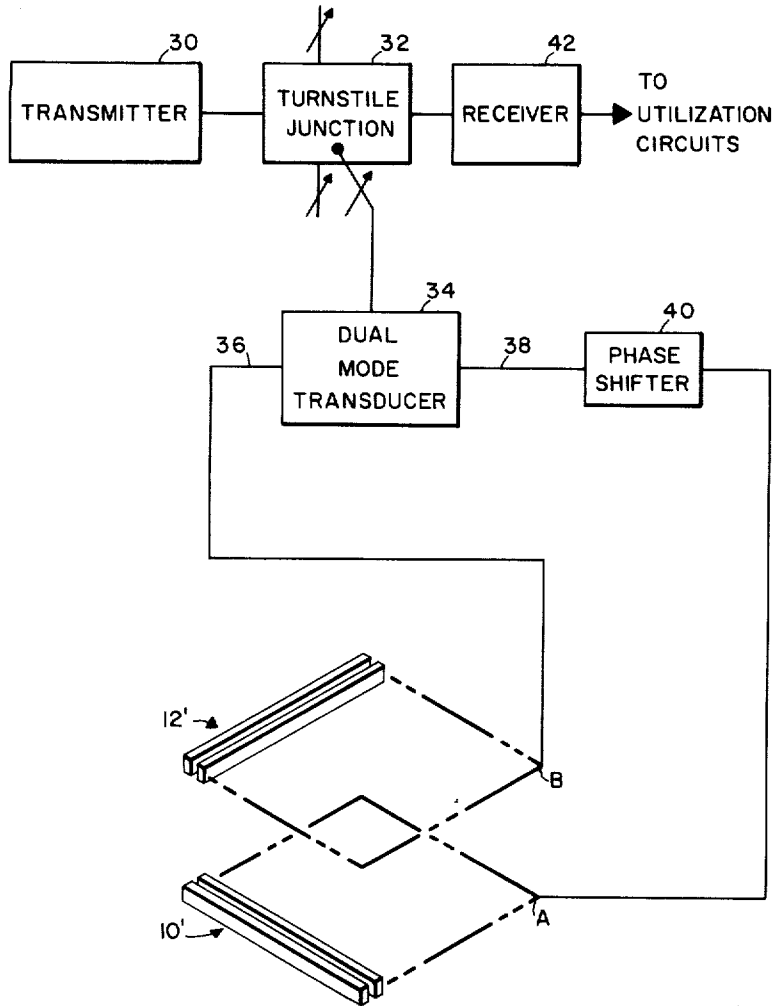

FIG. 2

INVENTOR
MAURICE DIAMOND

BY

Philip McFarland
ATTORNEY

1

3,247,512

MICROWAVE ANTENNA

Maurice Diamond, Framingham, Mass., assignor to Laboratory for Electronics, Inc., Boston, Mass., a corporation of Delaware

Filed Feb. 17, 1964, Ser. No. 345,222

4 Claims. (Cl. 343-9)

This invention pertains generally to antennas and particularly to an antenna for radiating high frequency electromagnetic energy in any one of a plurality of beams.

Airborne Doppler radar systems are known which employ an antenna for transmitting directional beams of microwave energy toward the surface of the earth and receiving "Doppler shifted" signals reflected therefrom. One known type of such antenna is the so-called Luneberg lens antenna, wherein a wide angle dielectric lens cooperates with a number of feed horns to produce the desired beams. Another known type of antenna which produces a plurality of directional beams is the so-called planar antenna, as for example, the antenna described in the application for patent (assigned to the same assignee as this application) Serial No. 193,717, entitled "Microwave Antenna," filed May 10, 1962, in the name of Alan J. Simmons, wherein a plurality of parallel sections of waveguides support a plurality of radiating slots to produce a beam when such sections are energized with microwave energy.

While both the just-mentioned types of antennas are satisfactory when it is desired to produce pencil beams (meaning beams having a circular cross-section), neither type may be used when it is desired to produce beams of other shapes. Further, neither type is well adapted to the simultaneous transmission of more than one beam or to changes in the polarization of the energy in the propagated beam or beams.

Therefore, it is a primary object of this invention to provide an improved beam forming antenna which is adapted to produce one or more independent beams of microwave energy at the same time.

Another object of this invention is to provide an improved beam forming antenna which is adapted to produce beams of microwave energy of differing cross-sectional shapes.

Another object of this invention is to provide an improved beam forming antenna which is adapted to produce beams of microwave energy wherein the polarization of such energy may be easily controlled.

Still another object of this invention is to provide an improved beam forming antenna which accomplishes the foregoing objects with compact, known elements.

These and other objects of this invention are accomplished by an antenna comprising a first and second planar array orthogonally disposed with respect to each other. The beam forming radiating elements of the first such array are preferably disposed parallel to each other and spaced from each other to allow the radiating slots in the radiating elements of the second such array to be disposed between the radiating elements of the first. The two arrays may be energized either simultaneously or sequentially making it possible to form, at any time, either a single beam, or a plurality of beams, and to control the polarization thereof. Further the shape of the beams may be controlled within wide limits by changing the arrange-

2

ment of the radiating slots in each array or by changing the manner in which each radiating element is energized. For a more complete understanding of this invention reference is now made to the drawings illustrating the invention and to the following detailed description.

In the drawings:

FIG. 1 is a simplified view taken from below of an antenna according to the invention (a portion of the structure being broken away in order to illustrate normally hidden elements), which antenna is adapted to provide three elliptical beams symmetrically disposed with respect to a line perpendicular to the plane of each array; and

FIG. 2 is a block diagram of a system according to an alternative embodiment of the invention.

Referring now to FIG. 1, it may be seen that one embodiment of an antenna according to this invention comprises a first planar array 10 and a second planar array 12 preferably in contact with one another and energized through wave guides 13, 14, 15. The latter elements, in turn, are connected through a radio frequency switch 16 of any conventional design to a transmitter/receiver 17. Signals out of the receiver portion of the last named element are, when the antenna is a portion of a Doppler radar system, fed to a tracker unit 18 and thence to an indicator 19.

The planar array 10 consists of a feed guide 21 integrally attached to and extending from the wave guide 13 and a plurality of radiating guides 23 affixed to the feed guide 21 as shown. The radiating guides 23 are parallel to each other and spaced as shown, there being a conventional matched load (unnumbered) affixed to the free end of each radiating guide 23 to prevent unwanted reflections. It is here noted that the spacing between adjacent radiating guides 23 is not critical, so long as such spacing is less than one half wavelength of the frequency of the signal radiated from the planar array 12. Further it is noted that the radiating slots 24 in the radiating guides 23 are arranged in the form of an approximate parallelogram as shown by the dotted line 1 to produce an elliptical beam when electromagnetic energy is passed through waveguide 13 to the planar array 10.

The planar array 12 is similar to the planar array 10 except that the radiating guides 23 of the former array are orthogonal to those of the latter. In addition, planar array 12 includes two feed guides 21a, 21b fed, respectively, by waveguides 14, 15. Still further, the radiating slots (unnumbered) of planar array 12 (which correspond here to the radiating slots 24 in array 10) are arranged between the radiating guides 23 so as to form an approximate parallelogram which is a mirror image (partially illustrated by dotted line 2) of the approximate parallelogram (dotted line 1) formed by the radiating slots 24 of array 10. That is to say the approximate parallelogram shape formed by the radiating slots in array 12 is the parallelogram of array 10 reversed or flipped over. The array 12 is energized from either waveguide 14 or waveguide 15 depending on the condition of the radio frequency switch 16.

In operation, planar array 10 radiates energy in a conventional manner. That is, when the radio frequency switch 16 is actuated so that energy passes through waveguide 13 to feed guide 21, such energy is distributed among the various radiating guides 23 and is radiated through the radiating slots 24. The resultant of the

energy from the radiating slots 24 is a beam, the inclination of which to the plane of the planar array 10 and the shape of which is dependent on the number and disposition of the radiating slots 24. Further, when the radiating slots 24 are disposed as shown, the polarization of the energy in the main beam radiated from the planar array 10 is, however, always in a plane substantially parallel to the radiating guides 23 of that array although the polarization of energy in the sidelobes may not necessarily be so polarized.

When the planar array 12 is energized from either waveguide 14 or 15, a beam is radiated in either one of two directions, depending upon which of the two waveguides is energized. Since the energy propagated from the planar array 12 must pass between the radiating guides 23 of planar array 10 and since, as noted hereinbefore, the spacing between adjacent ones of the radiating guides 23 of planar array 10 is less than one-half of the wavelength of the frequency of such radiated energy, it follows that the radiating guides 23 of planar array 10 affect any energy radiated from planar array 12. That is, the radiating guides 23 of planar array 10 selectively attenuate portions of the energy radiated from planar array 12 in accordance with the polarization of such energy. Energy polarized in a plane orthogonal to the radiating guides 23 of planar array 10 is not attenuated, whereas energy polarized in a plane parallel to the radiating guides 23 is, for all practical purposes, completely attenuated. The result then is that the energy in any beam originating at planar array 12 is polarized in a direction orthogonal to the radiating guides 23 of planar array 10.

It should be noted here that the antenna just described is intended to be energized so as to produce, sequentially, any one of three beams. It is evident, however, that beams from the planar array 10 are, for practical purposes independent of beams from the planar array 12. That is, since the plane of polarization of energy in any beam from the planar array 10 is in space quadrature with the plane of polarization of energy in any beam from the planar array 12, the beams from the two planar arrays are decoupled from one another even though the two planar arrays are energized simultaneously. It follows, then, that the two planar arrays may be so energized as to form beams simultaneously, if desired, without appreciable "cross-talk." Such beams would be particularly useful in a system such as the one described in the application filed November 5, 1963, Serial No. 321,500, by James L. Burrows entitled "Doppler Radar System" (which application is assigned to the same assignee as this application).

Referring now to FIG. 2, an arrangement for utilizing the antenna illustrated in FIG. 1 to produce a beam of circularly polarized microwave energy is shown. Thus, a transmitter 30 (which may be either a conventional continuous wave or pulsed transmitter) is connected to a conventional turnstile junction 32, as, for example, the type shown and described in U.S. Patent No. 2,858,535, issued October 28, 1958, entitled "Microwave Polarization Apparatus," to produce a circularly polarized microwave signal in a conventional dual mode transducer 34 which is connected in a known manner to a first and a second transmission line 36, 38. As is known, the orthogonal components of the circularly polarized microwave signal are divided by the dual mode transducer 34 so that one component passes down the first transmission line 36 and the other passes down the second transmission line 38. A conventional phase shifter 40 may be inserted in the transmission line 38 so that the phase of the signal appearing at the feed port (here marked "A") of a planar array 10' is in time quadrature with the phase of the signal appearing at the corresponding feed port of a planar array 12' (here marked "B"). The planar arrays 10', 12' are identical with the planar arrays 10, 12 of FIG. 1 except that the distribution of

the radiating slots in the former are similar so that the beams propagated by the two beams are of the same shape and are coaxial with each other.

It will be apparent now that the energy in the resultant beam from the planar arrays 10', 12' is circularly polarized. The direction of polarization, i.e. left hand or right hand may be made to be the same as the direction of polarization of the energy entering the dual mode transducer 34 by adjustment of the phase shifter 40.

Since energy reflected back to the planar arrays 10', 12', is, in the normal case, reversed 180° in polarity, such energy recombines in the dual mode transducer 34 to produce energy having a circular polarization opposite to the direction of polarization of the energy from the transmitter 30. The received energy then passes through the turnstile junction 32 to a receiver 42 and thence to utilization circuits, as the tracker unit 18 of FIG. 1.

It may be seen from the foregoing that the contemplated system utilizes passive decoupling means between the transmitter 30 and the receiver 42, in that the turnstile junction 32, once adjusted, performs the function of a conventional duplexer. This advantage is, however, ancillary to the main advantage of the just described system. That is, the use of the double planar array permits precise and stable control of the shape of the propagated beam.

It will be immediately evident to those having skill in the art that conventional radio frequency switches may be incorporated in the system shown in FIG. 2 to permit switching to other feed ports of the arrays 10', 12' whenever it is desired to produce beams in different directions from the beam formed when feed ports A, B are energized. Further, it will be evident that the cross-sectional shape of the beams may be changed as desired simply by changing the distribution of the radiating slots in the arrays 10', 12' and that the polarization of the beams may be readily changed from circular polarization of one hand to circular polarization of the other hand or to elliptical polarization of any degree. Since the foregoing and many other changes not mentioned are obvious, it is felt that the invention should not be restricted to the illustrated embodiments, but rather should be limited only by the spirit and scope of the appended claims.

I claim:

1. In an airborne Doppler navigator having a plurality of beams of electromagnetic energy, each illuminating a different area of the terrain beneath an aircraft, an antenna, comprising:

- (a) a first planar array having a plurality of parallel, spaced radiating members, each such member having radiating slots formed therein;
- (b) a second planar array having a plurality of parallel, spaced radiating members, each such member having radiating slots formed therein, the radiating members of the second planar array being disposed orthogonal to the radiating members of the first array and the radiating slots of the second array being interposed between the radiating members of the first array; and,
- (c) means for sequentially energizing the first and the second planar array to generate the plurality of beams.

2. A microwave antenna for producing a plurality of beams of microwave energy comprising:

- (a) a first planar array including a plurality of radiating waveguides disposed adjacent to one another in a parallel relationship, the distance between each pair of such waveguides being less than one-half the wavelength of the microwave energy radiated therefrom;
- (b) a second planar array, similar to the first planar array, but disposed orthogonally thereto on the side

5

thereof opposite to the side from which the microwave energy is radiated; and,

(c) means for feeding microwave energy to the first and the second planar array to produce the desired plurality of beams of microwave energy.

3. A microwave antenna as in claim 2 wherein the first and the second planar array are in substantially continuous electrical contact with one another at the overlapping portions thereof.

4. A microwave antenna as in claim 3 wherein the radiating elements in the radiating waveguides of the

6

first and the second planar array are disposed to produce substantially plane-polarized energy in spaced quadrature.

References Cited by the Examiner

UNITED STATES PATENTS

2,851,681	9/1958	Cohn	-----	343—5
2,865,020	12/1958	Wolinsky	-----	343—9

CHESTER L. JUSTUS, *Primary Examiner.*

R. D. BENNETT, *Assistant Examiner.*

5

10