

(No Model.)

W. H. HAWKINS.
GUTTER LEADER AND STRAINER.

No. 524,668.

Patented Aug. 14, 1894.

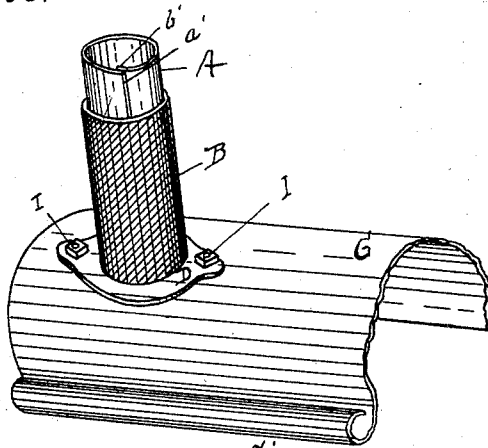

Fig. 1

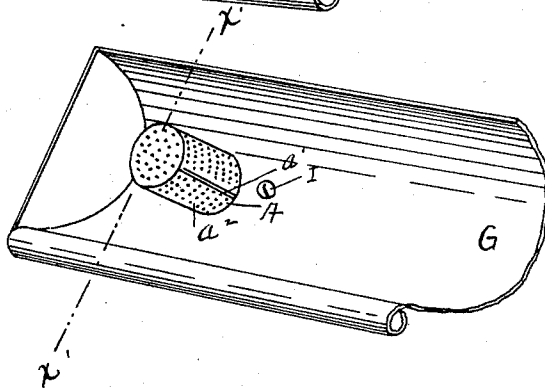

Fig. 2

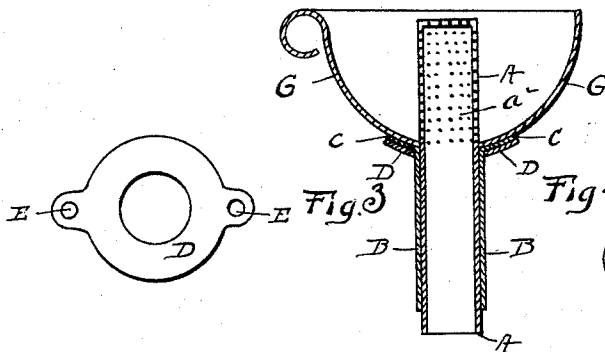

Fig. 3

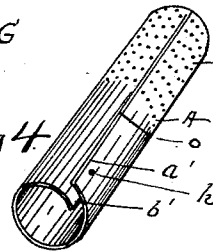

Fig. 4

Fig. 5

Witnesses

William A. Sweet
Geo. W. Demere

Inventor

William H. Hawkins

UNITED STATES PATENT OFFICE.

WILLIAM H. HAWKINS, OF SPRINGFIELD, MASSACHUSETTS.

GUTTER LEADER AND STRAINER.

SPECIFICATION forming part of Letters Patent No. 524,668, dated August 14, 1894.

Application filed February 23, 1894. Serial No. 501,270. (No model.)

To all whom it may concern:

Be it known that I, WILLIAM H. HAWKINS, of Springfield, in the county of Hampden and State of Massachusetts, have invented a new and useful Improvement in Gutter Leaders and Strainers, of which the following description and claims constitute the specification, and which is illustrated by the accompanying sheet of drawings.

The object of my improvement is to provide a gutter leader that water freezing therein will not burst, that forms a strainer preventing the passage of leaves and other obstructions into the conductor, and that may be quickly attached to the gutter without the use of solder.

Figure 1 of the drawings is a general view of the gutter inverted, showing collar, screw bolts, webbing and bottom of the strainer part of the leader. Fig. 2 is a general view of the gutter from the top, with strainer in place. Fig. 3 is a general view of the collar detached. Fig. 4 is a sectional view taken on line $x'-x'$ of Fig. 2. Fig. 5 is a general view of the inner or metallic part of the leader, one end of which is perforated for use as a strainer.

Similar letters refer to similar parts throughout the several views.

The part B, Fig. 1 is made of tubular webbing. It is rendered waterproof throughout by means of paint or other suitable material. Its upper end is formed into the shape of a circular flange c , Fig. 4.

The part A, Fig. 5 is made of flexible sheet metal having the perforations a^2 , slit o , and hole h . It is in the form of a scroll. Its perforated end is capped with perforated metal. Its end a' overlaps its end b' . It is free to be compressed or expanded throughout its entire length.

The collar D, having the screw holes E, Fig. 3, is made of sheet or cast metal.

I, Figs. 1 and 2, are screw bolts for use in fastening the collar D, carrying the webbing B, to the gutter G, Fig. 4.

The collar D receives the webbing B, Fig. 1. The flanged end c of the webbing B rests in the collar D which is shaped to conform to the contour of the gutter at its outlet, Fig. 4. The collar D, carrying the webbing B, is placed upon the under side of the gutter G

so that the flanged end c of the webbing B surrounds the outlet in the gutter G, Fig. 4, in which position the webbing B and collar D are made fast to the gutter G by means of the screw bolts I operating in and through screw holes in the gutter G and collar D, Figs. 1, 2 and 3.

The part A, Fig. 5 is inserted in the part B by compressing its bottom end sufficiently to enable it to be forced down through the outlet in the gutter G and webbing B until it projects an inch or so below the lower end of the webbing B, Fig. 1, which brings the lower portion of its perforated end on a line with the bottom of the gutter G Fig. 4.

When attached to the gutter in the manner before described, the part B forms a perfectly water tight, durable joint at the gutter outlet, but being an elastic, pliable texture, it would be liable to lose its required form, and by collapsing obstruct the drainage of the gutter, without the fixed and permanent use therein and therewith of the part A. I therefore claim that the part A is a necessary and essential feature of my improved gutter leader independently of its use as a strainer.

The gutter leader cannot be bursted or otherwise injured by reason of water freezing therein, as in that event the part A expands and the part B stretches sufficiently to prevent injury to either part. This I regard as being a most desirable and economical feature.

By means of the perforations a^2 in the part A Fig. 4 a practical, inexpensive and durable strainer is obtained which prevents the passage of obstructions into the conductor which received the bottom of the part A.

While my improved gutter leader and strainer may be quickly attached to all kinds of gutters ordinarily used in and upon buildings, it is particularly desirable for use in those made of galvanized iron, as leaders fastened to those gutters by means of solder are easily broken off for the reason that solder does not "take" upon that metal so as to form a strong, reliable joint.

What I claim is—

1. The combination of the webbing B, with the perforated flexible sheet metal strainer A, collar D, and gutter G, substantially as shown, for the purpose specified.

100

2. The combination with the collar D, screw bolts I, and gutter G, of the webbing B, having a flanged end c, and carrying the perforated flexible sheet metal strainer A, which it retains in position in the gutter and to which it is fastened by means of the collar D and screw bolts I, substantially as shown, for the purpose specified.

3. In a gutter leader, the webbing B, carrying the roll of flexible sheet metal A, for use as a strainer by means of its perforations a², and to preserve the required form of the

webbing B in its use as a gutter leader, substantially as described.

4. As a new article of manufacture, a gutter leader and strainer formed by combining the webbing B with the roll of perforated flexible sheet metal A, substantially as described.

WILLIAM H. HAWKINS.

Witnesses:

C. H. MASON,
JOHN NASH.