



(43) International Publication Date  
06 September 2024 (06.09.2024)

(51) International Patent Classification:  
Not classified

(21) International Application Number:  
PCT/IB2024/051722

(22) International Filing Date:  
22 February 2024 (22.02.2024)

(25) Filing Language: Italian

(26) Publication Language: English

(30) Priority Data:  
102023000003762 02 March 2023 (02.03.2023) IT

(71) Applicant: **BREMBO S.P.A.** [IT/IT]; Via Brembo, 25, I-24035 Curno, BERGAMO (IT).

(72) Inventors: **TRUFFELLO, Martina**; c/o BREMBO S.P.A., via Brembo, 25, I-24035 Curno, BERGAMO (IT).  
**SALVANESCHI, Elisa**; c/o BREMBO S.P.A., via Brembo, 25, I-24035 Curno, BERGAMO (IT).

(74) Agent: **DI BIASE, Fabio** et al.; c/o JACOBACCI & PARTNERS S.p.A., Via Senato, 8, I-20121 MILANO (IT).

(81) Designated States (unless otherwise indicated, for every kind of national protection available): AE, AG, AL, AM, AO, AT, AU, AZ, BA, BB, BG, BH, BN, BR, BW, BY, BZ, CA, CH, CL, CN, CO, CR, CU, CV, CZ, DE, DJ, DK, DM, DO, DZ, EC, EE, EG, ES, FI, GB, GD, GE, GH, GM, GT, HN, HR, HU, ID, IL, IN, IQ, IR, IS, IT, JM, JO, JP, KE, KG, KH, KN, KP, KR, KW, KZ, LA, LC, LK, LR, LS, LU, LY, MA, MD, MG, MK, MN, MU, MW, MX, MY, MZ, NA, NG, NI, NO, NZ, OM, PA, PE, PG, PH, PL, PT, QA, RO, RS, RU, RW, SA, SC, SD, SE, SG, SK, SL, ST, SV, SY, TH, TJ, TM, TN, TR, TT, TZ, UA, UG, US, UZ, VC, VN, WS, ZA, ZM, ZW.

(84) Designated States (unless otherwise indicated, for every kind of regional protection available): ARIPO (BW, CV, GH, GM, KE, LR, LS, MW, MZ, NA, RW, SC, SD, SL, ST, SZ, TZ, UG, ZM, ZW), Eurasian (AM, AZ, BY, KG, KZ, RU, TJ, TM), European (AL, AT, BE, BG, CH, CY, CZ,

(54) Title: BRAKING SYSTEM

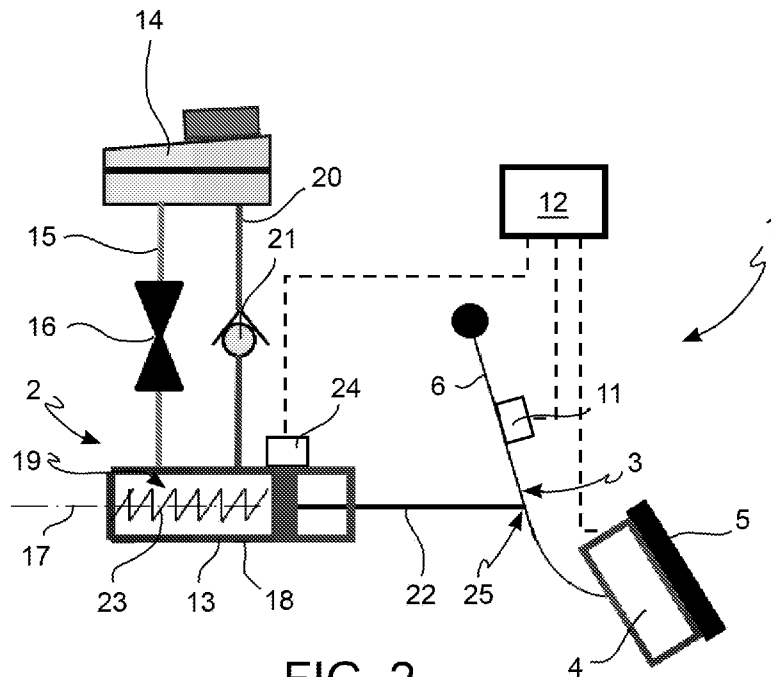

FIG. 2

(57) Abstract: A braking system (1), comprising a braking feel simulator device (2) and a brake pedal (3), wherein the brake pedal (3) is operatively connected to the braking feel simulator device (2), wherein the braking system (1) is configured so that an actuation of the brake pedal (3) by a driver corresponds to a reaction force applied by the braking feel simulator device (2) to the brake pedal (3) as opposed to an actuation of the brake pedal (3), wherein the braking system (1) further comprises a haptic feedback actuator (4) connected to the brake pedal (3), wherein the haptic feedback actuator (4) is configured to transmit a haptic feedback to the brake pedal (3).



WO 2024/180436 A2

DE, DK, EE, ES, FI, FR, GB, GR, HR, HU, IE, IS, IT, LT,  
LU, LV, MC, ME, MK, MT, NL, NO, PL, PT, RO, RS, SE,  
SI, SK, SM, TR), OAPI (BF, BJ, CF, CG, CI, CM, GA, GN,  
GQ, GW, KM, ML, MR, NE, SN, TD, TG).

**Published:**

- *without international search report and to be republished upon receipt of that report (Rule 48.2(g))*
- *in black and white; the international application as filed contained color or greyscale and is available for download from PATENTSCOPE*

**“Braking system”**

[0001] Field of the invention

[0002] The present invention is directed to a braking system of the Brake-By-Wire ("BBW") type of vehicles with two or more wheels, actuatable by a driver by means of a brake pedal or lever, and to a method of actuating a braking system.

[0003] Background art

[0004] In braking systems of the BBW type, there is a decoupling between force and displacement imparted on the brake pedal or lever by the driver and the resulting braking force which is applied by the calipers to the vehicle wheels.

[0005] In BBW braking systems, the force and displacement imparted by the driver on the brake pedal or lever are transduced into an electrical signal which is processed by a control unit to control the actuation of the braking system calipers.

[0006] Accordingly, it is known to equip the BBW braking systems with a braking feel simulator device connected to the brake pedal or lever and configured to simulate the feel and stiffness of a brake pedal or lever of conventional hydraulic braking systems, and thus emulate the "stiffness curve" thereof.

[0007] "Stiffness curve" means the relationship between the displacement of the brake pedal or lever along its stroke and the respective reaction force applied by the simulator device on the brake pedal or lever, and thus by the brake pedal or lever on the driver.

[0008] Driving safety and comfort strictly depend on the stiffness of the brake pedal or lever, implemented by the braking feel simulation devices.

[0009] Braking feel simulator devices comprising a master cylinder connected to the brake pedal are known.

[0010] The master cylinder comprises a float, which is moved by the driver's mechanical action on the brake pedal and has the function of pressurizing the hydraulic fluid.

[0011] The hydraulic fluid is contained in a reservoir fluidly connected to the master cylinder by means of a hydraulic connection.

[0012] Moreover, the master cylinder is fluidly connected by means of an additional hydraulic connection to an absorber, which is a device generally provided with a plurality of elastic elements arranged in series and in parallel, configured to apply an elastic reaction force as opposed to a brake pedal actuation.

[0013] In known BBW braking systems, the decoupling between the force applied to

the brake pedal by the driver and the braking force which is applied by the calipers to the wheels of the vehicle generates difficulties in returning haptic signals and feedback to the driver, such as the brake pedal shaking in a conventional braking system, which is triggered when the ABS system intervenes.

[0014] Moreover, both BBW and conventional hydraulic braking systems do not allow transmitting to the driver special alerts or warning signals related to the braking system itself, such as a parking brake engagement or disengagement warning.

[0015] A further criticality of the known BBW braking system is that the known simulator devices have large dimensions which make them difficult to install inside the passenger compartment of the vehicle, where there is less space available, in both the hanging brake pedal configuration and the flat brake pedal configuration. Due to the large dimensions, the known simulator devices are generally installed in the engine compartment of the vehicle, under the hood.

[0016] The high number of components also adversely affects the cost and maintenance requirements of the known simulator devices.

[0017] A further critical issue with known simulator devices concerns the real and perceived safety of the driver due to the presence of pressurized components inside the passenger compartment, such as a possible installation of the master cylinder of the simulator device close to the driver. Indeed, it is necessary to maintain a constant pressure of about 50 bar inside the master cylinder to ensure the braking action.

[0018] Solution

[0019] It is the object of the present invention to provide a braking system, of the BBW type, such as to obviate at least some of the drawbacks of the prior art.

[0020] It is a particular object of the present invention to provide a braking system configured to return and transmit haptic signals and feedbacks to the driver, such as the brake pedal shaking in a conventional braking system, which is triggered when the ABS intervenes, or an engagement or disengagement alert of the parking brake.

[0021] It is further a particular object of the present invention to provide a more compact braking system adapted to be installable inside the vehicle passenger compartment, in both the hanging brake pedal configuration and the flat brake pedal configuration.

[0022] It is a further particular object of the present invention to provide a braking system with lower costs and lower maintenance requirements.

[0023] It is a further particular object of the present invention to provide a braking system which has increased safety, both real and perceived by the driver.

[0024] These and other objects are achieved by a braking system according to claim 1.

[0025] The dependent claims relate to preferred and advantageous embodiments of the present invention.

[0026] Drawings

[0027] In order to better understand the invention and appreciate the advantages thereof, some non-limiting exemplary embodiments thereof will be described below with reference to the accompanying drawings, in which:

[0028] - figure 1 diagrammatically shows a braking system according to the prior art;

[0029] - figure 2 diagrammatically shows a braking system, according to an embodiment of the invention;

[0030] - figure 3 is a front perspective view of a braking pedal of a braking system according to an embodiment of the invention;

[0031] - figure 4 is a perspective rear view of the brake pedal shown in figure 3;

[0032] - figure 5 is a side view of the brake pedal shown in figure 3;

[0033] - figure 6 is a bottom view of the brake pedal shown in figure 3;

[0034] - figure 7 is an exploded perspective view of the brake pedal shown in figure 3;

[0035] - figure 8 is a perspective view of a braking feel simulator device of a braking system according to an embodiment of the invention;

[0036] - figure 9 is a longitudinal section view of the braking feel simulator device in figure 8.

[0037] Description of some preferred embodiments

[0038] The present invention relates to a braking system of the Brake-By-Wire ("BBW") type of vehicles with two or more wheels, actuatable by a driver by means of a brake pedal or lever. Therefore, in the present description, the term "brake pedal" means indistinctly both a brake pedal for motor vehicles and the like and a brake lever for motorcycles, mopeds, and the like, unless otherwise specified. Moreover, "electrically connected" means a connection for the transmission of electric power and/or electric signals.

[0039] Braking system 1

[0040] With reference to the figures, a braking system is generally indicated by reference numeral 1.

[0041] In particular, the braking system 1 is a braking system of the "BBW" type.

[0042] The braking system 1 comprises a braking feel simulator device 2.

[0043] Moreover, the braking system 1 comprises a brake pedal 3 operatively connected to the braking feel simulator device 2.

[0044] The braking system 1 is configured so that an actuation of the brake pedal 3 by a driver corresponds to a reaction force applied by the braking feel simulator device 2 to the brake pedal 3 as opposed to an actuation of the brake pedal 3.

[0045] According to an aspect of the invention, the braking system 1 further comprises a haptic feedback actuator 4.

[0046] The haptic feedback actuator 4 is connected to the brake pedal 3.

[0047] Moreover, the haptic feedback actuator 4 is configured to transmit a haptic feedback to the brake pedal 3.

[0048] Haptic feedback actuator 4 also means a "tactile feedback actuator".

[0049] Advantageously, the braking system 1 thus configured allows returning to the driver haptic signals and feedbacks, such as the shaking or vibration which is triggered when the ABS system intervenes, by transmitting an appropriate haptic feedback from the haptic feedback actuator 4 to the brake pedal 3.

[0050] Moreover, the braking system 1 thus configured allows transmitting, to the brake pedal 3 and thus to the driver, particular alerts or warning signals relating to the braking system 1 itself, such as an engagement or disengagement alert of the electronic parking brake ("EPB") or an activation or deactivation alert of the electronic stability control ("ESC"), or an engagement or disengagement alert of the ignition key of the vehicle, or a malfunction alert of the braking system 1, or a activation or deactivation alert of the regenerative braking. Moreover, the braking system 1 allows transmitting, to the brake pedal 3, an insufficient or excessively light braking force alert, and thus an indication to the driver to increase the braking force, e.g., under conditions in which the vehicle is approaching other vehicles and the current braking force is not sufficient to avoid a collision.

[0051] According to an embodiment, the haptic feedback actuator 4 is configured to transmit, to the brake pedal 3, a vibration transmitted according to one or a plurality of vibration modes, or vibration "patterns", e.g., a clicking vibration, an increasing or decreasing ramp vibration, a pulsed vibration, a continuous intensity vibration, or a vibration interspersed with pauses of different durations, or continuous intensity vibrations of different durations, or vibrations at different vibration frequencies, or vibrations of different vibration intensity. In particular, each vibration mode can correspond to a different signal or alert. Advantageously, a braking system 1 thus

configured allows transmitting modulated signals or alerts to a driver.

[0052] According to an embodiment, the haptic feedback actuator 4 is a piezoelectric actuator, or an eccentric rotating mass motor ("ERM"), or a linear resonant actuator ("LRA"), or a solenoid actuator, or a brushless actuator, or a stepper actuator, or a bass shaker actuator, or a voice coil 27 ("voice coil") or any combination thereof.

[0053] Preferably, the haptic feedback actuator 4 is a voice coil 27, preferably of passive type, i.e., electrically powered by an electrical power source outside the voice coil 27. In particular, the haptic feedback actuator 4 is powered by a battery or an electrical wiring. Preferably, the electrical wiring is integrated inside brake pedal 3, preferably inside a pedal crank 6 of the brake pedal 3. As a result, the electrical wiring is advantageously hidden from view and does not generate any obstacle for the driver.

[0054] According to an embodiment, the brake pedal 3 is the brake pedal of a motor vehicle.

[0055] According to an embodiment, the brake pedal 3 comprises a pedal 5 fixed to a pedal crank 6.

[0056] The pedal 5 is fixed to an end of the pedal crank 6. The opposite end of the pedal crank 6 is operatively connected to the braking feel simulator device 2.

[0057] The pedal 5 comprises a pressure wall 7 and an opposite fixing wall 8.

[0058] The pressure wall 7 faces the driver and is configured to be pressed by a driver's foot so as to actuate the brake pedal 3.

[0059] Instead, the fixing wall 8 faces the pedal crank 6 and is fixed to the pedal crank 6.

[0060] Moreover, the pedal crank 6 comprises a supporting wall 9 facing the pedal 5 and fixed to the pedal 5.

[0061] Specifically, the supporting wall 9 is fixed to the fixing wall 8 of the pedal 5.

[0062] According to an embodiment, the haptic feedback actuator 4 is positioned at the pedal 5.

[0063] According to an embodiment, the haptic feedback actuator 4 is positioned at the fixing wall 8 of the pedal 5.

[0064] According to an embodiment, the haptic feedback actuator 4 is positioned interposed between the pedal 5 and the pedal crank 6.

[0065] Specifically, the haptic feedback actuator 4 is positioned interposed between the fixing wall 8 of the pedal 5 and the supporting wall 9 of the pedal crank 6.

[0066] According to an embodiment, the supporting wall 9 forms a housing seat 10

delimited by a housing wall 28. The housing seat 10 is open towards the pedal 5.

[0067] According to the embodiment, the haptic feedback actuator 4 is housed inside the housing seat 10.

[0068] Preferably, the haptic feedback actuator 4 is a voice coil 27, i.e., a voice coil, inserted into the housing seat 10.

[0069] The haptic feedback actuator 4 is positioned against the pedal 5, preferably against the fixing wall 8 of the pedal 5. Advantageously, such a contact between the haptic feedback actuator and the pedal 5 promotes the transmission of vibrations from the haptic feedback actuator 4 to the pedal 5.

[0070] According to an embodiment, the haptic feedback actuator 4 is rigidly fixed to the housing wall 28.

[0071] According to an embodiment, the housing wall 28 is made of metal material.

[0072] Advantageously, such a configuration promotes the transmission of vibrations from the haptic feedback actuator 4 to the pedal 5, and thus to the driver, thus avoiding a damping of such vibrations.

[0073] According to an embodiment, the haptic feedback actuator 4 is positioned so as to transmit vibrations mainly along a transmission direction substantially transverse to the pressure wall 7 of the pedal 5.

[0074] According to an embodiment, the haptic feedback actuator 4 is positioned at a central portion of the pedal 5.

[0075] Advantageously, such a positioning promotes the transmission of vibrations from the haptic feedback actuator 4 to the pedal 5, and thus to the driver.

[0076] According to an embodiment, the voice coil 27 defines a symmetry axis 26. The voice coil 27 is positioned inside the housing 10 so that the symmetry axis 26 of the voice coil 27 is transverse to the fixing wall 8 and/or the pressure wall 7 of the pedal 5.

[0077] According to an embodiment, the voice coil 27 is configured to vibrate along a direction parallel to the symmetry axis 26.

[0078] Advantageously, a haptic feedback actuator 4 thus configured allows transmitting haptic signals to the driver more efficiently. Moreover, such a configuration allows transmitting the vibration of the voice coil 27 mainly along a direction substantially parallel to the direction of the force applied by a driver to the pedal 5.

[0079] According to an embodiment, the braking system 1 comprises at least a first sensor 11.

[0080] The at least a first sensor 11 is connected to the brake pedal 3.

[0081] The at least a first sensor 11 is configured to detect an actuation and/or movement of the brake pedal 3.

[0082] According to an embodiment, the at least a first sensor 11 is either a position sensor, or a pressure sensor, or a force sensor or a combination thereof.

[0083] According to an embodiment, the at least a first sensor 11 is either a laser position sensor, or an infrared pressure sensor, or an elastomeric sensor, or a piezoelectric sensor, or a Hall effect sensor, or a magnetoresistive sensor, or a linear magnetic sensor, or a microelectromechanical system ("MEMS"), or a fiber optic sensor, or a strain gage, or a proximity sensor, or an eddy current sensor, or a differential sine-cosine sensor, or a torque sensor, or a combination thereof.

[0084] According to an embodiment, the at least a first sensor 11 is connected to the pedal crank 6 of the brake pedal 3.

[0085] Advantageously, such a positioning of the at least a first sensor 11 at the pedal crank 6 increases and preserves the measurement accuracy of the at least a first sensor 11.

[0086] According to an embodiment, the at least a first sensor 11 is positioned at the end of the pedal crank 6 opposite to the pedal 5.

[0087] According to an embodiment, the at least a first sensor 11 is positioned at the pedal 5.

[0088] According to an embodiment, the at least a first sensor 11 is positioned at the haptic feedback actuator 4.

[0089] According to an embodiment, the braking system 1 comprises at least a second sensor 24.

[0090] The at least a second sensor 24 is distinct from the at least a first sensor 11.

[0091] The at least a second sensor 24 is configured to detect an actuation and/or a movement of the braking feel simulator device brake 2.

[0092] The at least a second sensor 24 is positioned at the braking feel simulator device 2.

[0093] According to an embodiment, the at least a second sensor 24 is configured to detect the movement of at least one component of the braking feel simulator device 2.

[0094] According to an embodiment, the at least a second sensor 24 is either a position sensor or a pressure sensor or a force sensor or a combination thereof.

[0095] According to an embodiment, the at least a second sensor 24 is either a laser position sensor, or an infrared pressure sensor, or an elastomeric sensor, or a

piezoelectric sensor, or a Hall effect sensor, or a magnetoresistive sensor, or a linear magnetic sensor, or a microelectromechanical system (“MEMS”), or a fiber optic sensor, or a strain gage, or a proximity sensor, or an eddy current sensor, or a differential sine-cosine sensor, or a torque sensor, or a combination thereof.

[0096] According to an embodiment, the braking system 1 comprises an electronic processing unit 12.

[0097] The electronic processing unit 12 is electrically connected to the haptic feedback actuator 4.

[0098] According to an embodiment, the electronic processing unit 12 is also electrically connected to the at least a first sensor 11.

[0099] According to an embodiment, the electronic processing unit 12 is also electrically connected to the at least a second sensor 24.

[00100] The electronic processing unit 12 is configured to control the haptic feedback actuator 4 to transmit a haptic feedback to the brake pedal 3. Specifically, the electronic processing unit 12 is configured to control the haptic feedback actuator 4 to transmit a haptic feedback to the brake pedal 3 upon the detection of an actuation and/or movement of the brake pedal 3 by the at least a first sensor 11 and/or upon an actuation and/or movement of the braking feel simulator device 2 by the at least a second sensor 24.

[00101] Braking feel simulator device 2

[00102] According to an embodiment, the braking feel simulator device 2 can be either of the dry type, i.e., not immersed in hydraulic fluid, or of the wet type, i.e., immersed in hydraulic fluid.

[00103] According to an embodiment, the braking feel simulator device 2 comprises a reservoir 14 and an absorber 13.

[00104] The reservoir 14 is configured to contain hydraulic fluid.

[00105] The absorber 13 is configured to apply a reaction force to the brake pedal 3 as opposed to an actuation of the brake pedal 3.

[00106] According to an embodiment, the absorber 13 is configured to contain the hydraulic fluid.

[00107] According to an embodiment, the reservoir 14 and the absorber 13 are fluidly connected directly to each other by means of a first hydraulic pipe 15.

[00108] Moreover, the first hydraulic pipe 15 comprises a calibrated orifice 16 interposed between the reservoir 14 and the absorber 13.

[00109] Specifically, the calibrated orifice 16 is configured to dampen a flow of

hydraulic fluid passing between the absorber 13 and the reservoir 14.

[00110] Advantageously, an actuation of the braking feel simulator device 2 thus configured, in response to an actuation of the brake pedal 3, conveys a flow of hydraulic fluid from the absorber 13 to the reservoir 14, which is damped by the calibrated orifice 16.

[00111] Such a damping, in combination with the contrasting action of the absorber 13, obtains the reaction force in response to an actuation of the brake pedal 3 which emulates the stiffness curve of a conventional braking system.

[00112] Advantageously, a braking system 1 comprising a braking feel simulator device 2 thus configured is more compact than the braking systems of the prior art and is adapted to be installable inside the passenger compartment of the vehicle, in both the hanging brake pedal configuration and the flat brake pedal configuration.

[00113] Indeed, the braking feel simulator device 2 thus configured lacks a master cylinder interposed between the reservoir 14 and the absorber 13 and thus has smaller overall size and volume.

[00114] Specifically, the braking feel simulator device 2 thus configured lacks hydraulic machines interposed between the reservoir 14 and the absorber 13.

[00115] With added advantage, a braking system 1 comprising a braking feel simulator device 2 thus configured is simplified compared to the prior art because it lacks a master cylinder. Such a simplification results in low costs and lower maintenance requirements.

[00116] With added advantage, a braking system 1 comprising a braking feel simulator device 2 thus configured has increased safety, both real and perceived by the driver.

[00117] Indeed, devices constantly subjected to high pressures, which would also require high sizing, are not present in the braking feel simulator device 2.

[00118] Conversely, the braking feel simulator device 2 is only subjected to a low transient pressure peak when the hydraulic fluid starts flowing from the absorber 13 to the reservoir 14.

[00119] The braking feel simulator device 2 is configured to contain hydraulic fluid, with fluid continuity, inside the absorber 13 and the reservoir 14.

[00120] According to an embodiment, the braking feel simulator device 2 comprises hydraulic fluid contained, with fluid continuity, inside the absorber 13 and the reservoir 14.

[00121] Therefore, in an operating configuration, the hydraulic fluid fills the absorber 13, the first hydraulic pipe 15, and at least partially the reservoir 14.

[00122] According to an embodiment of the invention, the absorber 13 extends along an actuation axis 17, between a first absorber end and an opposite second absorber end.

[00123] According to an embodiment, the first hydraulic pipe 15 extends along a direction substantially transverse to the actuation axis 17.

[00124] Advantageously, such a configuration reduces the overall volume of the braking feel simulator device 1.

[00125] According to an embodiment, the absorber 13 is configured to be connectable to the brake pedal 3 at the first end of the absorber.

[00126] Moreover, the absorber 13 is configured to be actuatable by the brake pedal 3 at the first absorber end.

[00127] According to an embodiment, the absorber 13 is configured so that an actuation of the brake pedal 3 corresponds to a pressurization of the hydraulic fluid contained in the absorber 13, which conveys a flow of hydraulic fluid from the absorber 13 to the reservoir 14, through the first hydraulic pipe 15.

[00128] According to an embodiment, the absorber 13 comprises a peripheral wall 18 extending substantially in a direction parallel to the actuation axis 17, between the first absorber end and the second absorber end.

[00129] The peripheral wall 18 defines a housing compartment 19 therein, configured to contain the hydraulic fluid.

[00130] According to an embodiment, the reservoir 14 comprises a containment wall and a bottom wall.

[00131] The bottom wall is substantially transverse to the containment wall.

[00132] The bottom wall and the containment wall form an inner compartment configured to contain the hydraulic fluid.

[00133] According to an embodiment, the containment wall forms a top-up opening. Preferably, the top-up opening is positioned opposite to the bottom wall.

[00134] The top-up opening is configured to allow a top-up of hydraulic fluid in the reservoir 14.

[00135] The top-up opening is closable by means of a cap.

[00136] According to an embodiment, the first hydraulic pipe 15 extends through the bottom wall of the reservoir 14 and the peripheral wall 18 of the absorber 13.

[00137] The first hydraulic pipe 15 thus fluidly connects the reservoir compartment to the housing compartment 19.

[00138] Advantageously, such a configuration reduces the overall volume of the braking feel simulator device 2.

[00139] According to an embodiment, the reservoir 14 is fixed to the absorber 13.

[00140] According to an embodiment, the reservoir 14 is made in one piece with the absorber 13.

[00141] According to an embodiment, the bottom wall extends in a plane substantially parallel to the actuation axis 17 and the containment wall is substantially transverse to the actuation axis 17.

[00142] According to an embodiment, the bottom wall of the reservoir 14 substantially coincides with a portion of the peripheral wall 18 of the absorber 13.

[00143] According to an embodiment, the reservoir 14 is at least partially interpenetrated with the absorber 13.

[00144] According to an embodiment, the bottom wall of the reservoir 14 is at least partially interpenetrated with the peripheral wall 18 of the absorber 13.

[00145] According to an alternative embodiment, the reservoir 14 is distinct from the absorber 13. The fluid connection between the reservoir 14 and the absorber 13 is ensured by the first hydraulic pipe 15.

[00146] Advantageously, the reservoir 14 thus configured is freely positionable and orientable with respect to the absorber 13.

[00147] According to an embodiment, the first hydraulic pipe comprises a flexible pipe, extending between the reservoir 14 and the absorber 13.

[00148] According to an embodiment, the calibrated orifice 16 is configured to generate the damping required by a driver.

[00149] According to an embodiment, the calibrated orifice 16 forms a section of diameter between 0.7 mm and 1.5 mm.

[00150] According to an embodiment, the calibrated orifice 16 has a length of less than 3.0 mm.

[00151] According to an embodiment, the first hydraulic pipe 15 has a length of less than 10.0 mm.

[00152] According to this embodiment, the distance between the reservoir compartment and the housing compartment 19 is less than 3.0 mm.

[00153] According to an embodiment, the first hydraulic pipe 15 has a length of less than 3.0 mm.

[00154] According to this embodiment, the distance between the reservoir

compartment and the housing compartment 19 is less than 3.0 mm.

[00155] According to an embodiment, the absorber 13 comprises at least one elastic element 23 positioned inside the housing compartment 19.

[00156] The at least one elastic element 23 is configured to apply a reaction force in response to an actuation of the braking feel simulation device 2. Specifically, the at least one elastic element 23 is configured to apply a reaction force to the brake pedal 3 in response to an actuation of the brake pedal 3 by a driver.

[00157] The at least one elastic element 23 is configured to be biased along a direction substantially parallel to the actuation axis 17.

[00158] According to an embodiment, the absorber 13 comprises a plurality of elastic elements 23 positioned in series and/or in parallel inside the housing compartment 19.

[00159] According to an embodiment, the elastic elements 23 comprise a plurality of helical compression springs positioned substantially coaxial to the actuation axis 17.

[00160] According to an embodiment, the elastic elements 23 comprise conical spring washers and/or square springs and/or torsion springs and/or strip springs and/or shaped springs.

[00161] According to an embodiment, in the operating configuration, the at least one elastic element 23 is immersed in the hydraulic fluid.

[00162] Preferably, the plurality of helical compression springs positioned substantially coaxial to the actuation axis 17 is immersed in the hydraulic fluid.

[00163] According to an embodiment, the braking feel simulator device 2 comprises a second hydraulic pipe 20 which fluidly connects the reservoir 14 to the absorber 13.

[00164] The second hydraulic pipe 20 is distinct from the first hydraulic pipe 15.

[00165] Advantageously, the second hydraulic pipe 20 is configured to allow for a faster return of hydraulic fluid from the reservoir 14 to the absorber 13 following the release of the actuation of the braking feel simulator device 2.

[00166] According to an embodiment, the second hydraulic pipe 20 comprises a check valve 21 interposed between the reservoir 14 and the absorber 13.

[00167] The check valve 21 is configured to allow a flow of hydraulic fluid from the reservoir 14 to the absorber 13, and prevent a flow of hydraulic fluid from the absorber 13 to the reservoir 14.

[00168] Therefore, during the actuation of the braking feel simulator device 2, the absorber 13 pushes the hydraulic fluid towards the reservoir 14, through the first hydraulic pipe 15 and the calibrated gap 16, which obtains a damping of the hydraulic

fluid flow. The check valve 21 ensures that the hydraulic fluid flow from the absorber 13 to the reservoir 14 flows through only the first hydraulic pipe 15. Conversely, upon the release of the braking feel simulator device 2, the hydraulic fluid flows out to the absorber 13 more rapidly, because it flows out through both the first hydraulic pipe 15 and the second hydraulic pipe 20.

[00169] According to an embodiment, the second hydraulic pipe 20 extends parallel to the first hydraulic pipe 15.

[00170] Advantageously, such a configuration reduces the overall volume of the braking feel simulator device 2.

[00171] According to an embodiment, the absorber 13 comprises a thrust shaft 22. The thrust shaft 22 is configured to be biased against the at least one elastic element 23, in response to an actuation of the brake pedal 3.

[00172] The thrust shaft 22 is positioned inside the housing compartment 19.

[00173] According to an embodiment, the thrust shaft 22 is configured to be biased by the brake pedal 3 in translation along the actuation axis 17 against the at least one elastic element 23. The absorber 13 thus applies a force opposed to the actuation of the brake pedal 3.

[00174] According to an embodiment, the at least a second sensor 24 is configured to detect a movement of the thrust shaft 22 inside the absorber 13.

[00175] Preferably, the at least a second sensor 24 is configured to detect a translation of the thrust shaft 22 along the actuation axis 17.

[00176] Advantageously, such a translation of the thrust shaft 22, actuatable by the brake pedal 3, can be correlated with the movement of the brake pedal 3 by a driver. The movement of the brake pedal 3 is usable to determine the braking force required by a driver from the braking system 1.

[00177] According to an embodiment, the at least one sensor 24 is positioned inside the absorber 13. Preferably, the at least a second sensor 24 is positioned inside the housing compartment 19.

[00178] According to an embodiment, the at least a second sensor 24 is positioned connected to the thrust shaft 22.

[00179] According to an embodiment, the brake pedal 3 is connected to the absorber 13 so that an actuation of the brake pedal 3 corresponds to a pressurization of the hydraulic fluid contained in the absorber 13, which conveys a flow of hydraulic fluid from the absorber 13 towards the reservoir 14, through the first hydraulic pipe 15.

[00180] According to an embodiment, the brake pedal 3 is connected to the absorber 13 by means of a mechanical connection 25, preferably by means of an articulated connection.

[00181] An actuation force applied by a driver to the brake pedal 3 is thus mechanically transferred to the absorber 13.

[00182] Advantageously, the connection between the brake pedal 3 and the absorber 13 lacks a hydraulic connection.

[00183] Specifically, the braking system 1 is configured so that an actuation of the brake pedal 3 by a driver corresponds to a reaction force applied by the braking feel simulator device 1 to the brake pedal 3 as opposed to an actuation of the brake pedal 3.

[00184] The reaction force applied by the braking feel simulator device 2 on the brake pedal 3 as opposed to an actuation of the brake pedal 3 is obtained by the combined counteracting action of the absorber 13 and the calibrated orifice 16.

[00185] The absorber 13 is configured to generate a reaction force as opposed to an actuation of the brake pedal 3, e.g., by means of the at least one elastic element 23 configured to counteract the actuation of the brake pedal 3.

[00186] The calibrated orifice 16 is configured to generate a damping force on the hydraulic fluid conveyed from the absorber 13 to the reservoir 14 through the first hydraulic pipe 15, under the actuation of the brake pedal 3, and such a damping force counteracts the actuation of the brake pedal 3.

[00187] The combined counteracting action of the absorber 13 and the calibrated orifice 16 is configured to simulate the feel and stiffness of a brake pedal or lever of the conventional hydraulic braking systems.

[00188] When the brake pedal 3 is released, the hydraulic fluid previously conveyed from the absorber 13 to the reservoir 14 flows out from the reservoir 14 to the absorber 13 passing through the first hydraulic pipe 15, and possibly also through the second hydraulic pipe 20.

[00189] According to an embodiment, the braking system 1 comprises a plurality of additional sensors electrically connected to the electronic processing unit 12.

[00190] According to an embodiment, the additional sensors are configured to detect at least one driving parameter, preferably a plurality of driving parameters.

[00191] According to an embodiment, the additional sensors are configured to detect one or more of the following driving parameters: an engagement or disengagement of the electronic parking brake ("EPB"), and/or an activation or deactivation of the electronic

stability control ("ESC"), and/or an insertion or removal of the vehicle ignition key, and/or a malfunction of the braking system 1, and/or an activation or deactivation of regenerative braking performed by the braking system 1, and/or to detect the intensity of the braking force actuated by the brake system 1, and/or to detect a distance of the vehicle in which the braking system 1 is integrated with respect to other vehicles.

[00192] Moreover, the electronic processing unit 12 is configured to control the haptic feedback actuator 4 to transmit a haptic feedback to the brake pedal 3 upon one or more of the previous detections performed by the additional sensors.

[00193] According to an embodiment, the braking system 1 comprises at least one brake caliper.

[00194] The electronic processing unit 12 is electrically connected to at least one brake caliper and to the braking feel simulator device 2 and/or the brake pedal 3.

[00195] The electronic processing unit is configured to actuate the at least one brake caliper upon the detection of an actuation and/or movement of the braking feel simulator device 2 and/or an actuation and/or movement of the brake pedal 3.

[00196] Method of actuating the braking system 1

[00197] According to a further aspect of the invention, there is described herein a method of actuating a braking system 1, as described above.

[00198] In particular, the braking system 1 is of the type comprising at least:

[00199] - a braking feel simulator device 2 and a brake pedal 3, where the brake pedal 3 is operatively connected to the braking feel simulator device 2, and where the braking system 1 is configured so that an actuation of the brake pedal 3 by a driver corresponds to a reaction force applied by the braking feel simulator device 2 to the brake pedal 3 as opposed to an actuation of the brake pedal 3;

[00200] - a haptic feedback actuator 4 connected to the brake pedal 3, where the haptic feedback actuator 4 is configured to transmit a haptic feedback to the brake pedal 3;

[00201] - an electronic processing unit 12;

[00202] - a plurality of additional sensors electrically connected to the electronic processing unit 12, and where the additional sensors are configured to detect at least one driving parameter, preferably a plurality of driving parameters.

[00203] The method comprises the steps of:

[00204] - detecting, by means of the additional sensors, at least one driving parameter, preferably a plurality of driving parameters;

[00205] - controlling, by means of the electronic processing unit 12, the haptic

feedback actuator 4 to transmit a haptic feedback to the brake pedal 3 at the one or more driving parameters detected by the additional sensors.

[00206] According to an embodiment, the method comprises the steps of:

[00207] - detecting, by means of the additional sensors, at least one of the following driving parameters:

[00208] - an engagement or disengagement of the electronic parking brake, and/or

[00209] - an activation or deactivation of the electronic stability control, and/or

[00210] - an insertion or removal of the vehicle ignition key, and/or

[00211] - a malfunction of the braking system 1, and/or

[00212] - an activation or deactivation of the regenerative braking performed by the braking system 1, and/or

[00213] - a distance of the vehicle in which the braking system is integrated 1 with respect to other vehicles, and/or

[00214] - the intensity of the braking force actuated by the braking system 1 on the vehicle,

[00215] - controlling, by means of the electronic processing unit 12, the haptic feedback actuator 4 to transmit a haptic feedback to the brake pedal 3 upon the detection of at least one of the driving parameters detected by the additional sensors.

[00216] According to an embodiment, the method comprises the steps of:

[00217] - detecting, by means of the additional sensors, a distance of the vehicle in which the braking system 1 is integrated with respect to other vehicles;

[00218] - detecting, by means of the additional sensors, the intensity of the braking force actuated by the braking system 1 on the vehicle;

[00219] - calculating, by means of the electronic processing unit 12, whether the intensity of the braking force actuated by the braking system 1 on the vehicle and detected by the additional sensors is sufficient to prevent a collision with other vehicles, and

[00220] - if not, controlling, by means of the electronic processing unit 12, the haptic feedback actuator 4 to transmit a haptic feedback to the brake pedal 3.

[00221] According to a further aspect of the invention, there is described herein a method of actuating a braking system 1, as described above.

[00222] In particular, the braking system 1 is of the type comprising at least:

[00223] - a braking feel simulator device 2;

[00224] - a brake pedal 3, where the brake pedal 3 is operatively connected to the braking feel simulator device 2, and where the braking system 1 is configured so that an actuation of the brake pedal 3 by a driver corresponds to a reaction force applied by the braking feel simulator device 2 to the brake pedal 3 as opposed to an actuation of the brake pedal 3;

[00225] - a haptic feedback actuator 4 connected to the brake pedal 3, where the haptic feedback actuator 4 is configured to transmit a haptic feedback to the brake pedal 3;

[00226] - an electronic processing unit 12;

[00227] - at least a first sensor 11 and/or at least a second sensor 24 electrically connected to the electronic processing unit 12.

[00228] The method comprises the steps of:

[00229] - detecting, by means of the at least a first sensor 11, an actuation and/or movement of the brake pedal 3; or

[00230] - detecting, by means of the at least a second sensor 24, an actuation and/or movement of the braking feel simulator device 2;

[00231] - controlling, by means of the electronic processing unit 12, the haptic feedback actuator 4 to transmit a haptic feedback to the brake pedal 3 upon the detection performed by the at least a first sensor 11 or the at least a second sensor 24.

[00232] Optionally, the previously described methods comprise the further steps of:

[00233] - associating, by means of the electronic processing unit 12, a distinct vibration mode with each driving parameter detectable by the additional sensors and/or the at least a first sensor 11 and/or the at least a second sensor 24;

[00234] - detecting, by means of the additional sensors and/or the at least a first sensor 11 and/or the at least a second sensor 24, a plurality of driving parameters;

[00235] - controlling, by means of the electronic processing unit 12, the haptic feedback actuator 4 to transmit a haptic feedback to the brake pedal 3 according to the vibration mode associated with the respective driving parameter.

[00236] Advantageously, such a method allows transmitting alerts and signals to the driver more effectively because each different alert and signal is associated with a different vibration mode.

[00237] Obviously, those skilled in the art will be able to make changes or adaptations to the present invention, without however departing from the scope of the following claims.

List of reference signs

1. Braking system
2. Braking feel simulator device
3. Brake pedal
4. Haptic feedback actuator
5. Pedal
6. Pedal crank
7. Pressure wall
8. Fixing wall
9. Supporting wall
10. Housing seat
11. First sensor
12. Electronic processing unit
13. Absorber
14. Reservoir
15. First hydraulic pipe
16. Calibrated orifice
17. Actuation axis
18. Peripheral wall
19. Housing compartment
20. Second hydraulic pipe
21. Check valve
22. Thrust shaft
23. Elastic element
24. Second sensor
25. Mechanical connection
26. Symmetry axis
27. Voice coil
28. Housing wall

### Claims

**1.** A braking system (1), comprising a braking feel simulator device (2) and a brake pedal (3), wherein the brake pedal (3) is operatively connected to the braking feel simulator device (2),

wherein the braking system (1) is configured so that an actuation of the brake pedal (3) by a driver corresponds to a reaction force applied by the braking feel simulator device (2) to the brake pedal (3) as opposed to an actuation of the brake pedal (3),

wherein the brake system (1) comprises a haptic feedback actuator (4) connected to the brake pedal (3),

and wherein the haptic feedback actuator (4) is configured to transmit a haptic feedback to the brake pedal (3).

**2.** A braking system (1) according to claim 1, wherein the haptic feedback actuator (4) is configured to transmit to the brake pedal (3) a vibration transmitted according to one or a plurality of the following vibration modes:

- click vibration
- increasing or decreasing ramp vibration
- pulse vibration
- continuous intensity vibration
- vibration intermitted with pauses of different durations
- continuous intensity vibrations of different durations
- vibrations at different vibration frequencies
- vibrations of different vibration intensities.

**3.** A braking system (1) according to claim 1 or 2, wherein the haptic feedback actuator (4) is:

- a piezoelectric actuator, or
- an eccentric rotating mass motor, or
- a linear resonant actuator, or
- a solenoid actuator, or
- a brushless actuator, or
- a stepper actuator, or
- a bass shaker actuator, or
- a voice coil (27), or
- a combination thereof,

and/or wherein the haptic feedback actuator (4) is a passive-type voice coil (27), and optionally wherein the haptic feedback actuator (4) is powered by an electrical wiring integrated inside the brake pedal (3).

**4.** A braking system (1) according to one of the preceding claims, wherein the brake pedal (3) comprises a pedal (5) fixed to a pedal crank (6), wherein the pedal (5) is fixed to an end of the pedal crank (6), and wherein the opposite end of the pedal crank (6) is operatively connected to the braking feel simulator device (2), wherein the pedal (5) comprises a pressure wall (7) and an opposite fixing wall (8), wherein the pressure wall (7) faces the driver and is configured to be pressed by a driver's foot so as to actuate the brake pedal (3), wherein the fixing wall (8) faces the pedal crank (6) and is fixed to the pedal crank (6), wherein the pedal crank (6) comprises a supporting wall (9) facing the pedal (5) and fixed to the fixing wall (8) of the pedal (5), and wherein the haptic feedback actuator (4) is positioned at the pedal (5).

**5.** A braking system (1) according to claim 4, wherein the haptic feedback actuator (4) is positioned to be interposed between the fixing wall (8) of the pedal (5) and the supporting wall (9) of the pedal crank (6).

**6.** A braking system (1) according to claim 4 or 5, wherein the supporting wall (9) forms a housing seat (10) delimited by a housing wall (28) and open towards the pedal (5), wherein the haptic feedback actuator (4) is housed inside the housing seat (10), and wherein, preferably, the haptic feedback actuator (4) is a voice coil (27) inserted into the housing seat (10), and/or wherein the haptic feedback actuator (4) is positioned abutting against the pedal (5), and/or wherein the haptic feedback actuator (4) is rigidly fixed to the housing wall (28), and/or wherein the housing wall (28) is made of a metal material, and/or wherein the haptic feedback actuator (4) is positioned so as to transmit vibrations mainly along a transmission direction substantially transverse to the pressure wall (7) of the pedal (5), and/or wherein the haptic feedback actuator (4) is positioned at a central portion of the pedal (5),

and, preferably, the voice coil (27) defines a symmetry axis (26), and the voice coil (27) is positioned inside the housing seat (10) so that the symmetry axis (26) of the voice coil (27) is transverse to the fixing wall (8) and/or the pressure wall (7) of the pedal (5), and wherein the voice coil (27) is preferably configured to vibrate along a direction parallel to the symmetry axis (26).

**7.** A braking system (1) according to any one of the preceding claims, comprising at least a first sensor (11),

wherein the at least a first sensor (11) is connected to the brake pedal (3) and is configured to detect an actuation and/or movement of the brake pedal (3),

and, preferably, wherein the at least a first sensor (11) is:

- a position sensor, or
- a pressure sensor, or
- a force sensor, or
- a laser position sensor, or
- an infrared position sensor, or
- an elastomeric sensor, or
- a piezoelectric sensor, or
- a Hall effect sensor, or
- a magnetoresistive sensor, or
- a linear magnetic sensor, or
- a micro-electromechanical system, or
- a fiber-optic sensor, or
- a strain gauge, or
- a proximity sensor, or
- an eddy current sensor, or
- a differential sine-cosine sensor, or
- a torque sensor, or
- a combination thereof.

**8.** A braking system (1) according to claims 7 and 4, wherein the at least a first sensor (11) is connected to the pedal crank (6) of the brake pedal (3), preferably at an end of the pedal crank (6) opposite to the pedal (5),

or wherein the at least a first sensor (11) is positioned at the haptic feedback actuator (4).

**9.** A braking system (1) according to any one of the preceding claims, comprising at least a second sensor (24),  
wherein the at least a second sensor (24) is configured to detect an actuation and/or movement of the braking feel simulator device (2), and is positioned at the braking feel simulator device (2),

and, preferably, wherein the at least a second sensor (24) is:

- a position sensor, or
- a pressure sensor, or
- a force sensor, or
- a laser position sensor, or
- an infrared position sensor, or
- an elastomeric sensor, or
- a piezoelectric sensor, or
- a Hall effect sensor, or
- a magnetoresistive sensor, or
- a linear magnetic sensor, or
- a micro-electromechanical system, or
- a fiber-optic sensor, or
- a strain gauge, or
- a proximity sensor, or
- an eddy current sensor, or
- a differential sine-cosine sensor, or
- a torque sensor, or
- a combination thereof.

**10.** A braking system (1) according to claims 7 and 9, comprising an electronic processing unit (12),

wherein the electronic processing unit (12) is electrically connected to the haptic feedback actuator (4), the at least a first sensor (11), and the at least a second sensor (24),

and wherein the electronic processing unit (12) is configured to control the haptic feedback actuator (4) to transmit a haptic feedback to the brake pedal (3) upon the detection of an actuation and/or movement of the brake pedal (3) by the at least a first sensor (11) and/or upon the detection of an actuation and/or movement of the braking

feel simulator device (2) by the at least a second sensor (24).

**11.** A braking system (1) according to any one of the preceding claims, wherein the braking feel simulator device (2) comprises a reservoir (14) and an absorber (13), wherein the reservoir (14) is configured to contain hydraulic fluid, and the absorber (13) is configured to apply a reaction force to the brake pedal (3) opposing an actuation of the brake pedal (3),

wherein the reservoir (14) and the absorber (13) are directly fluidly connected to each other by means of a first hydraulic pipe (15),

wherein the absorber (13) extends along an actuation axis (17), between a first absorber end and an opposite second absorber end, and comprises a peripheral wall (18) substantially extending in a direction parallel to the actuation axis (17), between the first absorber end and the second absorber end,

wherein the peripheral wall (18) defines a housing compartment (19) therein, configured to contain the hydraulic fluid,

wherein the absorber (13) comprises at least one elastic element (23) positioned inside the housing compartment (19),

wherein the absorber (13) comprises a thrust shaft (22) configured to be biased against the at least one elastic element (23) in response to an actuation of the brake pedal (3), wherein the thrust shaft (22) is positioned inside the housing compartment (19), and wherein the thrust shaft (22) is configured to be biased by the brake pedal (3) in translation along the actuation axis (17) against the at least one elastic element (23) so that the absorber (13) applies a force opposed to the actuation of the brake pedal (3), and wherein the at least a second sensor (24) is configured to detect a movement of the thrust shaft (22) inside the absorber (13),

and/or wherein the at least a second sensor (24) is configured to detect a translation of the thrust shaft (22) along the actuation axis (17),

and/or the at least a second sensor (24) is positioned inside the absorber (13),

and/or the at least a second sensor (24) is positioned inside the housing compartment (19),

and/or the at least a second sensor (24) is positioned to be connected to the thrust shaft (22).

**12.** A braking system (1) according to any one of the preceding claims, comprising an electronic processing unit (12) electrically connected to the haptic feedback actuator (4),

and a plurality of additional sensors electrically connected to the electronic processing unit (12),

wherein the additional sensors are configured to detect at least one driving parameter, preferably one or more of the following driving parameters:

- an engagement or disengagement of the electronic parking brake, and/or
- an activation or deactivation of the electronic stability control, and/or
- an insertion or removal of the vehicle ignition key, and/or
- a malfunction of the braking system (1), and/or
- an activation or deactivation of the regenerative braking performed by the braking system (1), and/or
- the intensity of the braking force actuated by the braking system (1), and/or
- a distance of the vehicle in which the braking system is integrated (1) with respect to other vehicles,

and wherein the electronic processing unit (12) is configured to control the haptic feedback actuator (4) to transmit a haptic feedback to the brake pedal (3) upon one or more of said detections performed by the additional sensors.

**13.** A method of actuating a brake system (1) of the type comprising at least:

- a braking feel simulator device (2);
- a brake pedal (3), wherein the brake pedal (3) is operatively connected to the braking feel simulator device (2), and wherein the braking system (1) is configured so that an actuation of the brake pedal (3) by a driver corresponds to a reaction force applied by the braking feel simulator device (2) to the brake pedal (3) as opposed to an actuation of the brake pedal (3);
- a haptic feedback actuator (4) connected to the brake pedal (3), wherein the haptic feedback actuator (4) is configured to transmit a haptic feedback to the brake pedal (3);
- an electronic processing unit (12);
- a plurality of additional sensors electrically connected to the electronic processing unit (12), and wherein the additional sensors are configured to detect at least one driving parameter, preferably a plurality of driving parameters;

the method comprising the steps of:

- detecting, by means of the additional sensors, at least one driving parameter, preferably a plurality of driving parameters;
- controlling, by means of the electronic processing unit (12), the haptic feedback actuator (4) to transmit a haptic feedback to the brake pedal (3) at the one or more driving

parameters detected by the additional sensors.

**14.** A method according to claim 13, comprising the steps of:

- detecting, by means of the additional sensors, at least one of the following driving parameters:

- an engagement or disengagement of the electronic parking brake, and/or
- an activation or deactivation of the electronic stability control, and/or
- an insertion or removal of the vehicle ignition key, and/or
- a malfunction of the braking system (1), and/or
- an activation or deactivation of the regenerative braking performed by the braking system (1), and/or
- a distance of the vehicle in which the braking system is integrated (1) with respect to other vehicles, and/or
- the intensity of the braking force actuated by the braking system (1) on the

vehicle,

- controlling, by means of the electronic processing unit (12), the haptic feedback actuator (4) to transmit a haptic feedback to the brake pedal (3) upon the detection of at least one of the driving parameters detected by the additional sensors,

or, wherein the method comprises the steps of:

- detecting, by means of the additional sensors, the distance of the vehicle in which the braking system is integrated (1) with respect to other vehicles;
- detecting, by means of the additional sensors, the intensity of the braking force actuated by the braking system (1) on the vehicle;
- calculating, by means of the electronic processing unit (12), whether the intensity of the braking force actuated by the braking system (1) on the vehicle and detected by the additional sensors is sufficient to prevent a collision with other vehicles, and
- if not, controlling, by means of the electronic processing unit (12), the haptic feedback actuator (4) to transmit a haptic feedback to the brake pedal (3).

**15.** A method of actuating a braking system (1) of the type comprising at least:

- a braking feel simulator device (2);
- a brake pedal (3), wherein the brake pedal (3) is operatively connected to the braking feel simulator device (2), and wherein the braking system (1) is configured so that an actuation of the brake pedal (3) by a driver corresponds to a reaction force applied by the braking feel simulator device (2) to the brake pedal (3) as opposed to an actuation of

the brake pedal (3);

- a haptic feedback actuator (4) connected to the brake pedal (3), wherein the haptic feedback actuator (4) is configured to transmit a haptic feedback to the brake pedal (3);
- an electronic processing unit (12);
- at least a first sensor (11) and/or at least a second sensor (24) electrically connected to the electronic processing unit (12);

the method comprising the steps of:

- detecting, by means of the at least a first sensor (11), an actuation and/or movement of the brake pedal (3); or
- detecting, by means of the at least a second sensor (24), an actuation and/or movement of the braking feel simulator device (2);
- controlling, by means of the electronic processing unit (12), the haptic feedback actuator (4) to transmit a haptic feedback to the brake pedal (3) upon the detection performed by the at least a first sensor (11) or the at least a second sensor (24).

**16.** A method according to one of claims 13 to 15, comprising the further steps of:

- associating, by means of the electronic processing unit (12), a distinct vibration mode with each driving parameter detectable by the additional sensors and/or the at least a first sensor (11) and/or the at least a second sensor (24);
- detecting, by means of the additional sensors and/or the at least a first sensor (11) and/or the at least a second sensor (24), a plurality of driving parameters;
- controlling, by means of the electronic processing unit (12), the haptic feedback actuator (4) to transmit a haptic feedback to the brake pedal (3) according to the vibration mode associated with the respective driving parameter.

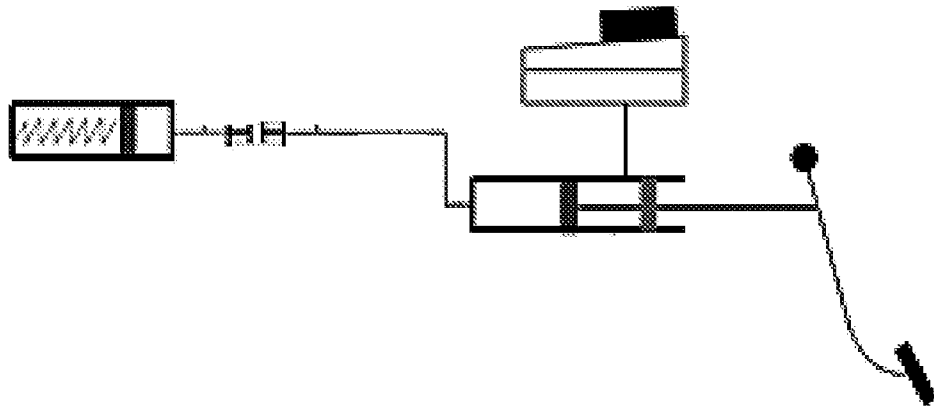

FIG. 1

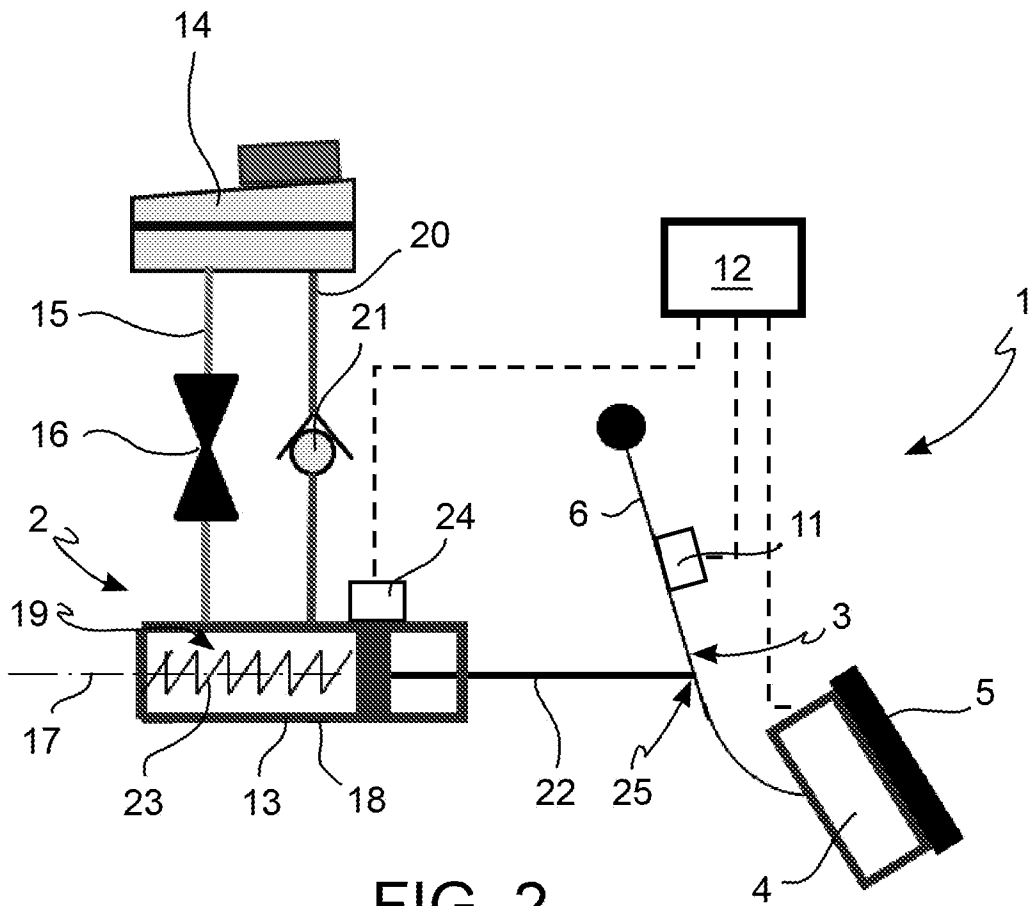

FIG. 2

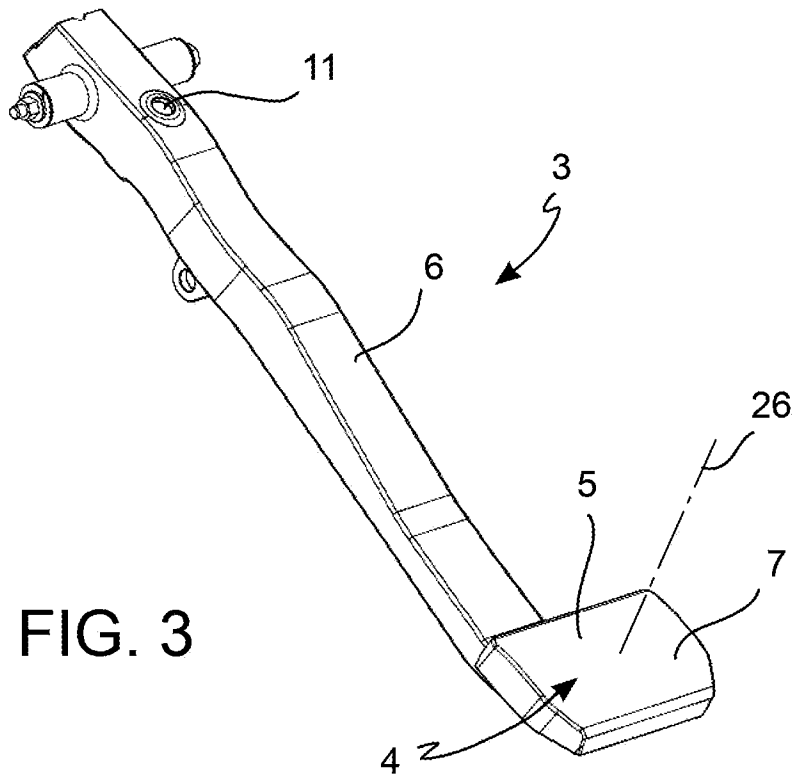

FIG. 3

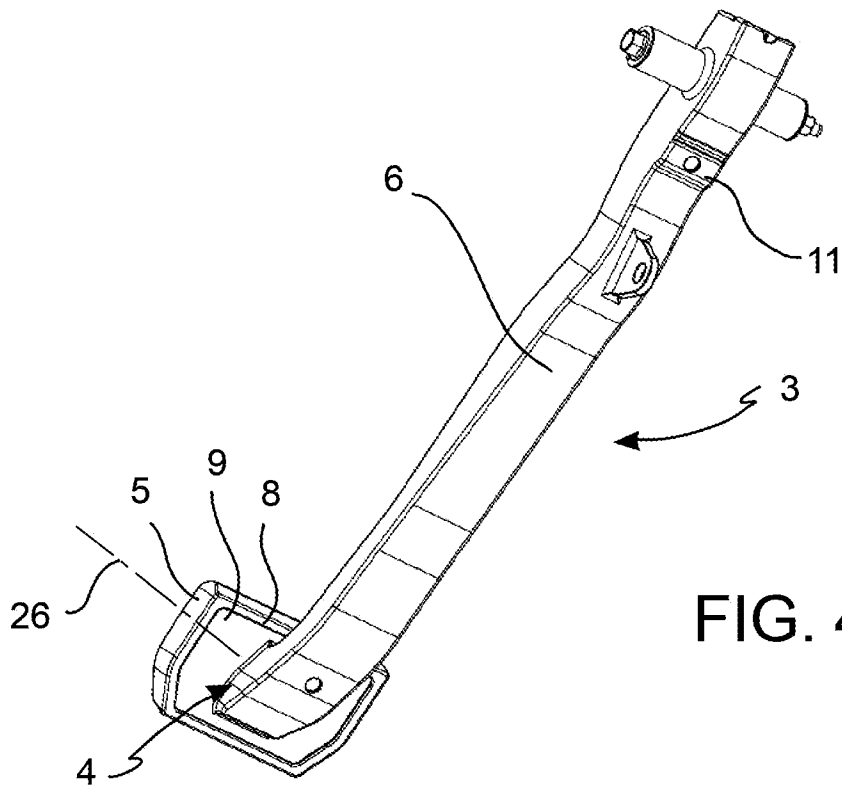
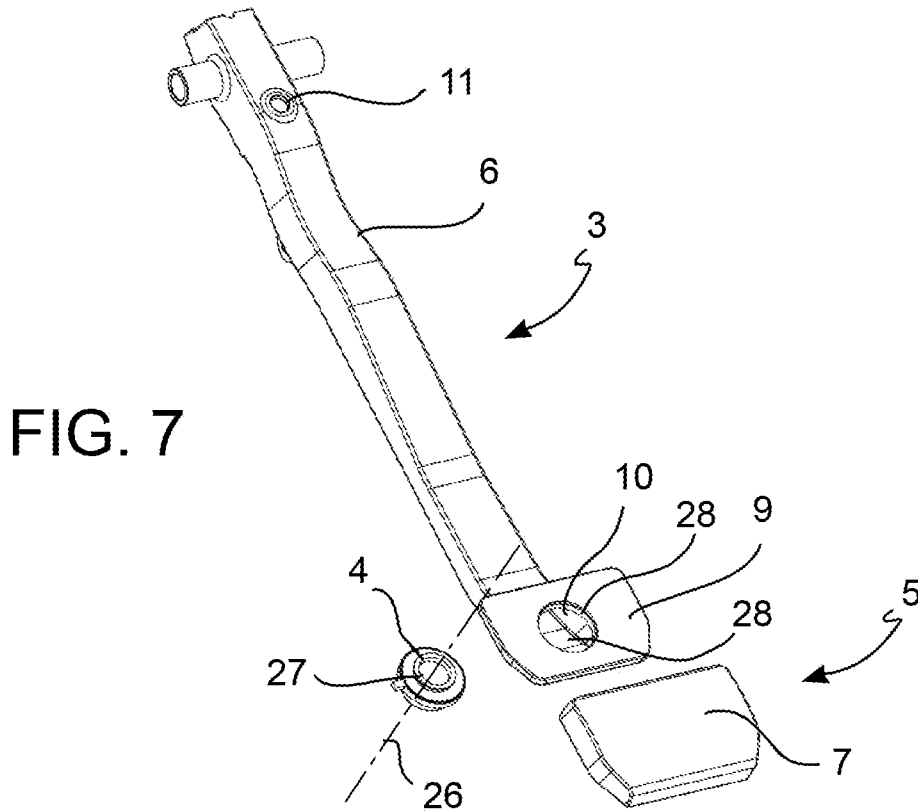
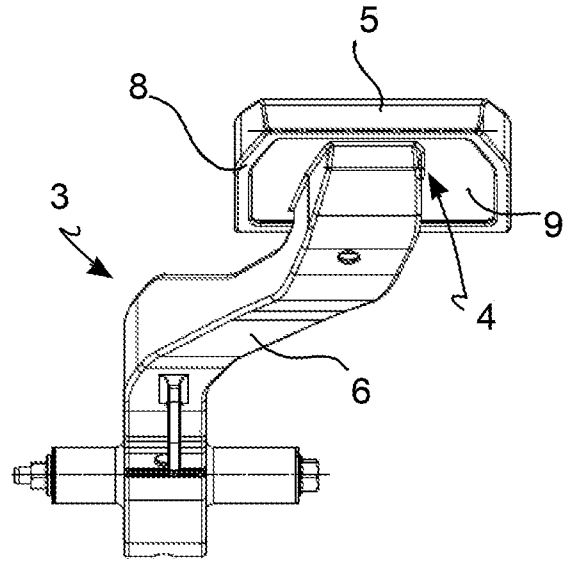
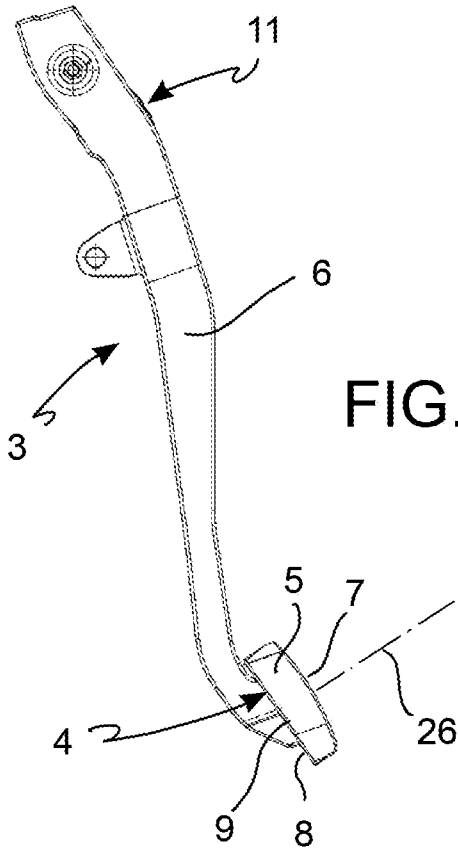

FIG. 4



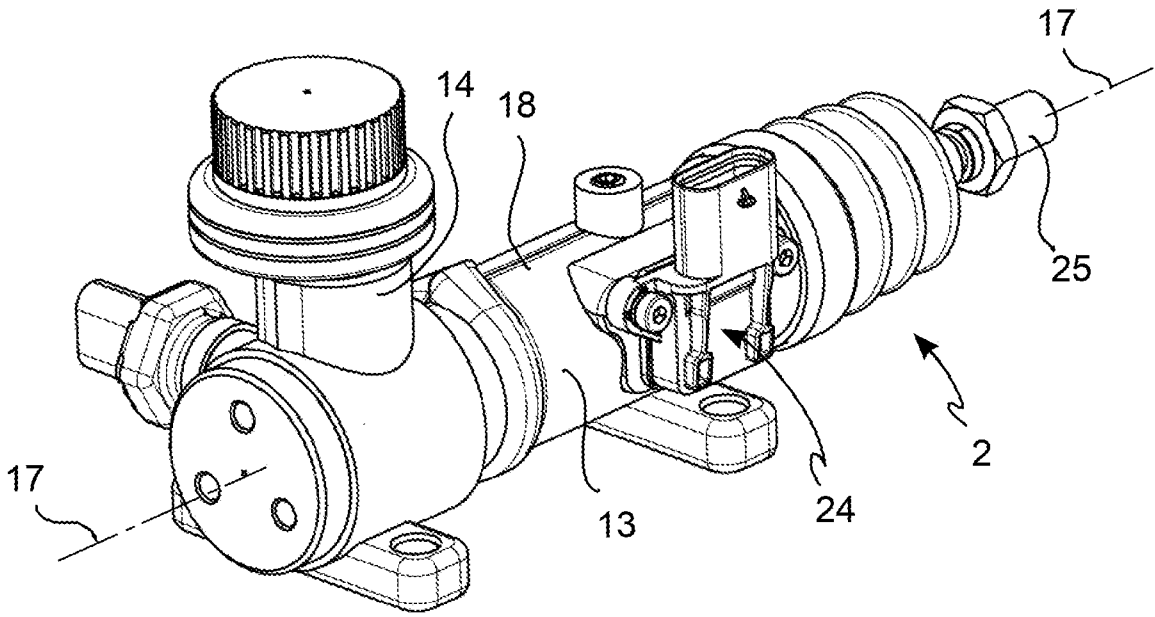

FIG. 8

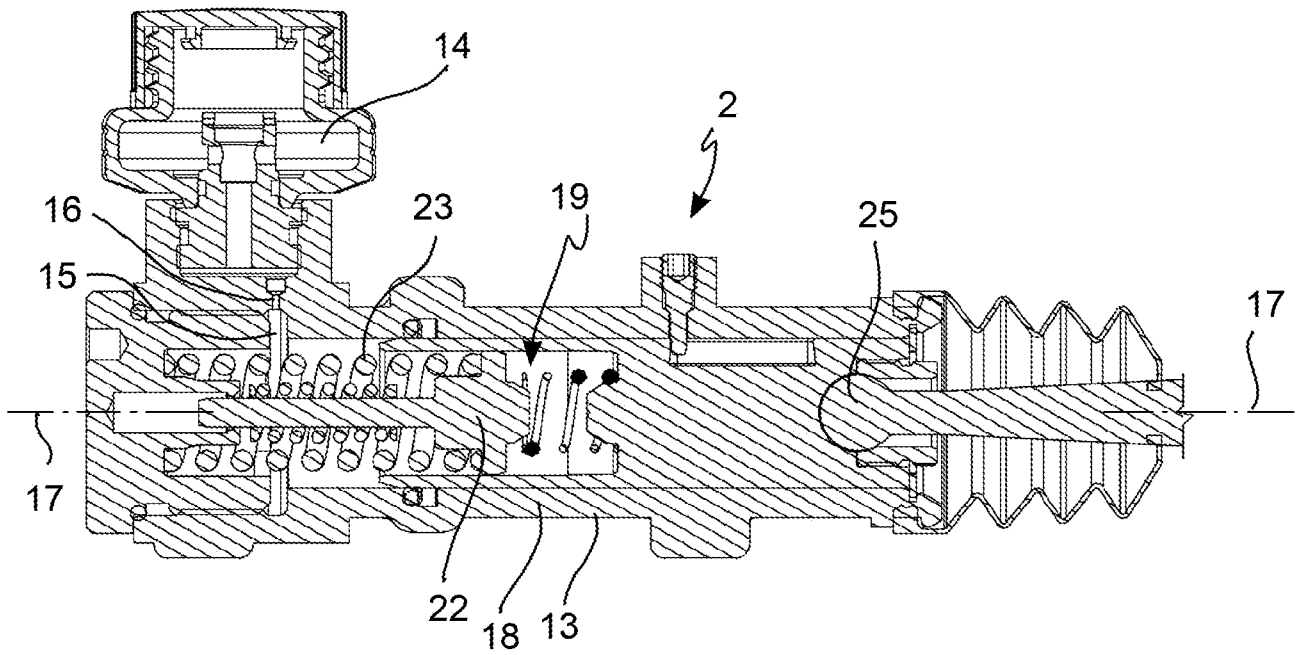

FIG. 9