

(19) World Intellectual Property Organization
International Bureau



(43) International Publication Date
24 June 2004 (24.06.2004)

PCT

(10) International Publication Number
WO 2004/052455 A1

(51) International Patent Classification⁷: A61N 1/375, 1/36

896 Ashland Avenue, St. Paul, MN 55104 (US). CABAK, James, E.; 3725 Ximines Ln. N., Plymouth, MN 55441 (US).

(21) International Application Number:
PCT/US2003/038938

(74) Agent: GREGSON, Richard, J.; Shumaker & Sieffert, P.A., Suite 105, 8425 Seasons Parkway, St. Paul, MN 55125 (US).

(22) International Filing Date: 9 December 2003 (09.12.2003)

(25) Filing Language: English

(26) Publication Language: English

(30) Priority Data:
60/431,854 9 December 2002 (09.12.2002) US
60/471,262 16 May 2003 (16.05.2003) US
60/503,945 20 September 2003 (20.09.2003) US
60/503,946 20 September 2003 (20.09.2003) US
60/507,857 1 October 2003 (01.10.2003) US

(81) Designated States (national): AE, AG, AL, AM, AT, AU, AZ, BA, BB, BG, BR, BY, BZ, CA, CH, CN, CO, CR, CU, CZ, DE, DK, DM, DZ, EC, EE, ES, FI, GB, GD, GE, GH, GM, HR, HU, ID, IL, IN, IS, JP, KE, KG, KP, KR, KZ, LC, LK, LR, LS, LT, LU, LV, MA, MD, MG, MK, MN, MW, MX, MZ, NI, NO, NZ, OM, PG, PH, PL, PT, RO, RU, SC, SD, SE, SG, SK, SL, SY, TJ, TM, TN, TR, TT, TZ, UA, UG, UZ, VC, VN, YU, ZA, ZM, ZW.

(71) Applicant: MEDTRONIC, INC. [US/US]; 710 Medtronic Parkway, Minneapolis, MN 55432 (US).

(84) Designated States (regional): ARIPO patent (BW, GH, GM, KE, LS, MW, MZ, SD, SL, SZ, TZ, UG, ZM, ZW), Eurasian patent (AM, AZ, BY, KG, KZ, MD, RU, TJ, TM), European patent (AT, BE, BG, CH, CY, CZ, DE, DK, EE, ES, FI, FR, GB, GR, HU, IE, IT, LU, MC, NL, PT, RO, SE, SI, SK, TR), OAPI patent (BF, BJ, CF, CG, CI, CM, GA, GN, GQ, GW, ML, MR, NE, SN, TD, TG).

(72) Inventors: JANZIG, Darren, A.; 1909 73rd St., Centerville, MN 55048 (US). WAHLSTRAND, Carl, D.; 6347 Langer Lane, Lino Lakes, MN 55038 (US). SKIME, Robert, M.; 2357 132nd Avenue NW, Coon Rapids, MN 55448 (US). LENT, Mark, S.; 4516 Edinbrook Terrace, Brooklyn Park, MN 55433 (US). MIESEL, Keith, A.;

Published: — with international search report

[Continued on next page]

(54) Title: COUPLING MODULE OF A MODULAR IMPLANTABLE MEDICAL DEVICE

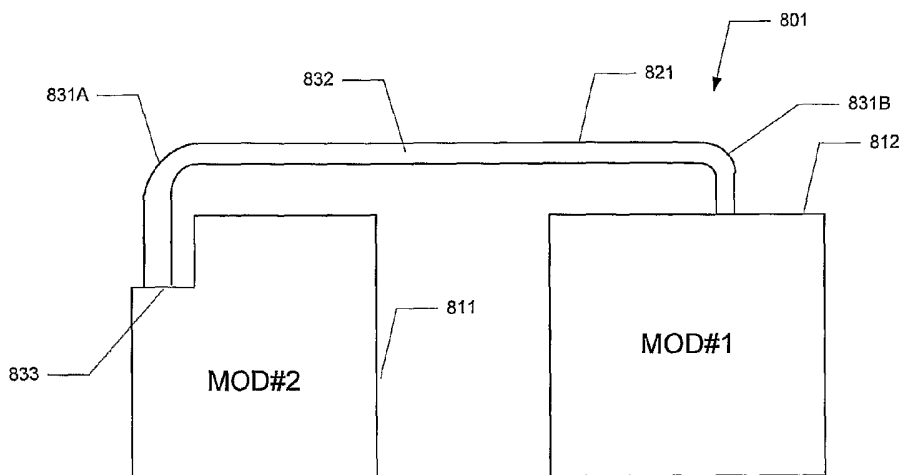

(57) Abstract: In an implantable medical device (101, 201, 401A-F, 501, 601, 701, 801, 901) having individual modules (103-105, 210-212, 410-412, 510-512, 610-611, 711-713, 811-812, 911-912, 1110-1111, 1201-1202), a coupling module (521, 612, 721, 722, 821, 921, 1001, 1101, 1222) couples the modules to one another. The coupling module supports electrical and/or mechanical coupling of the modules. The coupling module may assume a variety of shapes or configurations. The various embodiments of the coupling module may offer the modules varying degrees of freedom of movement relative to one another.

WO 2004/052455 A1



-
- *before the expiration of the time limit for amending the claims and to be republished in the event of receipt of amendments*
- For two-letter codes and other abbreviations, refer to the "Guidance Notes on Codes and Abbreviations" appearing at the beginning of each regular issue of the PCT Gazette.*

**COUPLING MODULE OF A MODULAR IMPLANTABLE MEDICAL
DEVICE**

[0001] This application claims the benefit of:

1. U.S. Provisional Application entitled "CRANIAL NEUROSTIMULATOR AND METHOD," Serial No. 60/431,854, (Attorney Docket No. P-10891.00), filed on December 9, 2002;
2. U.S. Provisional Application entitled "Implantable Cranial Medical Devices and Methods," Serial No.60/471,262, (Attorney Docket No. P-11462.00), filed on May 16, 2003;
3. U.S. Provisional Application entitled "IMPLANTABLE CRANIAL MEDICAL DEVICES AND METHODS," Serial No.60/503,945, (Attorney Docket No. P-11696.00), filed on September 20, 2003;
4. U.S. Provisional Application entitled "IMPLANTABLE CRANIAL MEDICAL DEVICES AND METHODS," Serial No. 60/503,946, (Attorney Docket No. P-11697.00), filed on September 20, 2003; and
5. U.S. Provisional Application entitled "Thin Neuro Stimulation System, Device and Method," Serial No. 60/507,857, (Attorney Docket No. P-20211.00), filed on October 1, 2003.

[0002] The following co-pending and commonly-assigned related U.S. Patent Applications are filed on even date herewith:

1. U.S. Patent Application entitled "MODULAR IMPLANTABLE MEDICAL DEVICE," to Carl D. Wahlstrand et al., filed December 9, 2003, assigned Attorney Docket No.: 1023-318US01/P-10891.00;
2. U.S. Patent Application entitled "IMPLANTATION OF LOW-PROFILE IMPLANTABLE MEDICAL DEVICE," to Ruchika Singhal et al., filed December 9, 2003, assigned Attorney Docket No.: 1023-330US01/P-11795.00;
3. U.S. Patent Application entitled "OVERMOLD FOR A MODULAR IMPLANTABLE MEDICAL DEVICE," to Ruchika Singhal et al., filed December 9, 2003, assigned Attorney Docket No.: 1023-332US01/P-11798.00;
4. U.S. Patent Application entitled "REDUCING RELATIVE INTER-MODULE MOTION IN A DISTRIBUTED MODULAR IMPLANTABLE

MEDICAL DEVICE,” to Carl D. Wahlstrand et al., filed December 9, 2003, assigned Attorney Docket No.: 1023-333US01/P-11797.00;

5. U.S. Patent Application entitled “LEAD CONNECTION MODULE OF A MODULAR IMPLANTABLE MEDICAL DEVICE,” to Ruchika Singhal et al., filed December 9, 2003, assigned Attorney Docket No.: 1023-334US01/P-11799.00;

6. U.S. Patent Application entitled “LOW-PROFILE IMPLANTABLE MEDICAL DEVICE,” to Darren A. Janzig et al., filed December 9, 2003, assigned Attorney Docket No.: 1023-335US01/P-11801.00; and

7. U.S. Patent Application entitled “CONCAVITY OF AN IMPLANTABLE MEDICAL DEVICE,” to Carl D. Wahlstrand et al., filed December 9, 2003, assigned Attorney Docket No.: 1023-336US01/P-11800.00.

8. U.S. Patent Application entitled “MODULAR IMPLANTABLE MEDICAL DEVICE,” to Carl D. Wahlstrand et al., filed December 9, 2003, assigned Attorney Docket No.: P-20542.00.

[0003] The invention relates to medical devices, and more particularly, to implantable medical devices that deliver therapy to and/or monitor a patient.

[0004] In one embodiment, the invention is directed to an implantable medical device that includes at least two modules, each of the modules comprising a housing. The IMD also includes a coupling module coupled to each of the modules. The coupling module defines at least one lumen between the modules and permits motion of the two modules along at least one axis of motion.

[0005] Depending on the application for which they are implanted in a patient, implantable medical devices (IMDs) may include a variety of electrical and/or mechanical components. Typically, an IMD includes a rigid housing that houses all of its components, which are generally fragile, to protect the components from forces to which they would otherwise be exposed when implanted within the human body. In order to avoid potentially harmful interactions between the components and bodily fluids, e.g., corrosion, IMD housings are typically hermetically sealed. Many IMD housings are fabricated from titanium because of its desirable rigidity and biocompatibility.

[0006] The size and shape of an IMD housing is dependant on the sizes and shapes of the components of the IMD. Large components common to most IMDs include a battery, a telemetry coil, and a hybrid circuit that includes digital circuits, e.g., integrated circuit chips and/or a microprocessor, and analog circuit components. Attempts have been made to reduce the size of the IMD housing by reducing the size of these components, changing the shape of these components, and organizing these components within the IMD housing to avoid empty space within the housing. Despite these efforts to reduce the size of IMD housings, the size, shape and rigidity of IMD housings still greatly limits the locations within the human body where an IMD can be practically implanted.

[0007] Due to these limitations, an IMD is typically implanted within the abdomen, upper pectoral region, or subclavicular region of a patient. Leads or catheters must be used in order to deliver therapy or monitor a physiological parameter at a location of the body other than where the IMD is implanted. Implantation and positioning of leads and catheters can be difficult and time-consuming from the perspective of a surgeon, particularly where the IMD is located a significant distance from the treatment or monitoring site. Moreover, the increased surgical time, increased surgical trauma, and increased amount of implanted material associated with the use of leads and catheters can increase the risk to the patient of complications associated with the implantation of an IMD.

[0008] For example, IMDs that are used to treat or monitor the brain, e.g., to deliver deep brain stimulation (DBS) therapy, are implanted some distance away from the brain, e.g., within the subclavicular region of patients. The long leads that connect the implantable medical device to electrodes implanted within the brain require tunneling under the scalp and the skin of the neck, thereby requiring increased surgery and a prolonged amount of time under general anesthesia during the implant procedure. The lengthy tract along the leads is more susceptible to infection, and the leads can erode the overlying scalp, forcing removal so that the scalp can heal. Further, the long leads running under the scalp and through the neck are more susceptible to fracture due to torsional and other forces caused by normal head and neck movements.

[0009] In general, the invention relates to a coupling module for a modular implantable medical device. In order to provide an implantable medical device with a smaller profile so that the IMD can better fit into available body locations, various functional components of the IMD are separated into individual interconnected modules. This modular architecture for the implantable medical device permits the device footprint to be distributed over a larger area while making the profile smaller.

[0010] The multiple modules and their respective flexible interconnections are typically coupled to one another mechanically and electrically. Electrical coupling permits the modules to receive power or signals from one another, for example. Mechanical coupling helps constrain the modules while also providing some freedom of movement. In general, it is desirable that a modular IMD include some freedom of movement, so that the IMD may conform to the body location into which it is to be implanted. The present invention is directed to one or more coupling mechanisms for the modular component modules within the implantable medical device. The coupling mechanisms support mechanical and electrical coupling of the modules.

[0011] In one embodiment, the invention is directed to an implantable medical device that includes at least two modules, each of the modules comprising a housing. The IMD also includes a coupling module coupled to each of the modules. The coupling module defines at least one lumen between the modules and permits motion of the two modules along at least one axis of motion.

[0012] In another embodiment, the invention presents a device comprising a first module that includes control electronics comprising a first housing, a second module comprising a second housing, and a coupling module fixedly coupled to the first and second housings. The coupling module defines at least one lumen and permits motion of the first housing relative to the second housing and along at least one axis of motion. The coupling module may assume a variety of configurations. The coupling module may include, for example, multiple lumens, a shaped cross-section or a helical portion.

[0013] The details of one or more embodiments of the invention are set forth in the accompanying drawings and the description below. Other features, objects, and

advantages of the invention will be apparent from the description and drawings, and from the claims.

[0014] FIGS. 1A and 1B are diagrams illustrating use of an implantable medical device in a patient according to an example embodiment of the present invention.

[0015] FIG. 2 is a schematic diagram illustrating an implantable medical device according to another embodiment of the present invention.

[0016] FIG. 3A and 3B are schematic diagrams illustrating an implantable medical device according to another embodiment of the present invention.

[0017] FIGS. 4A-4F are schematic diagrams illustrating various orientations of multiple modules within an implantable medical device according to various embodiments of the present invention.

[0018] FIG. 5A is a schematic diagram illustrating the construction of an overmold and modules used in construction of an implantable medical device according to the present invention.

[0019] FIG. 5B is an exploded view of an embodiment of the overmold and modules shown in FIG. 5A.

[0020] FIG. 5C is a side view of an embodiment of the overmold and modules shown in FIG. 5A.

[0021] FIGS. 6A-6C are schematic diagrams illustrating distributed modules and a coupling module with a single degree of freedom of motion according to an embodiment of the present invention.

[0022] FIGS. 7A-7B are schematic diagrams illustrating distributed modules having a one or more coupling modules with two degrees of freedom of motion according to an embodiment of the present invention.

[0023] FIG. 8 is schematic diagram illustrating distributed modules having a coupling module with three degrees of freedom of motion according to an embodiment of the present invention.

[0024] FIG. 9 is schematic diagram illustrating distributed modules having a coupling module having a hermetic and non-hermetic interconnection according to an embodiment of the present invention.

[0025] FIGS. 10A-10I are schematic diagrams illustrating exemplary shapes, configurations and features of a coupling module according to embodiments of the present invention.

[0026] FIGS. 11A-11M are schematic diagrams illustrating configurations of multiple modules and a coupling module according to embodiments of the present invention.

[0027] FIGS. 12A-12C are schematic diagrams illustrating module interfaces with a coupling module according to an embodiment of the present invention.

[0028] FIG. 13 is a schematic diagram illustrating the axes of motion present in a multi-module implantable medical device.

[0029] FIGS. 14A-14C are a schematic diagrams illustrating motion restriction of a multi-module implantable medical device.

[0030] FIGS. 15A-15B are schematic diagrams illustrating the interaction of components of an implantable medical device that are part of an overmold according to the present invention.

[0031] FIGS. 16A-16B are a perspective diagrams illustrating a multi-module implantable medical device having an triangular module arrangement and a coupling module according to the present invention.

[0032] FIGS. 1A and 1B are diagrams illustrating use of an implantable medical device (IMD) in a patient according to an example embodiment of the present invention. An IMD101 is implanted within a patient 100 in order to permit IMD101 to provide therapies to the patient 100. In the example illustrated within FIGS. 1A-1B, IMD101 is implanted under the scalp of the patient 100 in order to locate the device 101 as close as possible to the location of leads 102 that provide the therapy.

[0033] FIG. 1A shows patient 100 with IMD 101 deployed beneath his scalp. In FIG. 1A, IMD 101 is a neurostimulator that provides deep brain stimulation via leads 102 deployed in the brain of patient 100. IMD 101 is deployed in proximity to site of stimulation therapy. IMD 101 may be used to treat any nervous system disorder including, but not limited to, epilepsy, pain, psychological disorders including mood and anxiety disorders, movement disorders (MVD) such as, but

not limited to, essential tremor and Parkinson's disease and neurodegenerative disorders.

[0034] Although IMD 101 is depicted as a neurostimulator, the invention is not limited to applications in which the IMD is a neurostimulator. The invention may be employed with IMDs that perform any monitoring or therapeutic functions. The invention is not limited to IMDs that include leads deployed in the brain, but may also be employed with leads deployed anywhere in the head or neck including, for example, leads deployed on or near the surface of the skull, leads deployed beneath the skull such as near or on the dura mater, leads placed adjacent cranial or other nerves in the neck or head, or leads placed directly on the surface of the brain. Nor is the invention limited to IMDs that are coupled to electrodes. The invention may be employed with IMDs coupled to any sensing or therapeutic elements, such as temperature sensors or motion sensors. The invention may also be employed with different types of IMDs including, but not limited to, IMDs operating in an open loop mode (also referred to as non-responsive operation), IMDs operating in a closed loop mode (also referred to as responsive), and IMDs for providing monitoring and/or warning.

[0035] In general, IMD 101 has a low profile, i.e., IMD 101 is thin to permit IMD 101 to be deployed effectively, comfortably and cosmetically and under the scalp. In one embodiment of the invention, IMD 101 has a maximum thickness of between approximately 4 millimeters and approximately 8 millimeters. The use of a reduced profile may reduce the risk of infection, skin erosion and cosmetic issues related to the implantation of IMD 101.

[0036] Many locations within a patient do not present adequate profile for implantable medical devices. As such, many uses of such devices employ lengthy leads located remote from an implantation site of the IMD. The use of these lengthy leads requires complicated insertion procedures from the site of the IMD to the site of lead deployment that may cause medical complications to the patient as well as may lead to failures in connection leads. By constructing IMD 101 as a set of distributed modules connected together as described herein, IMD 101 may be deployed proximate to a treatment or monitoring site.

[0037] While the embodiment of IMD 101 shown in FIGS. 1A-1B is implanted under the scalp of patient 100 and may be used when the therapy provided to patient 100 includes neural stimulation of a brain, other embodiments of IMD 100 permit the device to be implanted at many other locations within the body. In addition, IMD 101 includes a plurality of interconnected modules. Each module generally perform assigned functions.

[0038] In the typical embodiment depicted in FIG. 1B, IMD 101 includes three modules, namely, a control module 103, a power supply module 104 and a recharge module 105. Control module 103 typically includes the electronic components associated with the functions of IMD 101. In a typical implementation, control module 103 may include a hybrid circuit that includes digital circuits such as integrated circuit chips and one or more microprocessors, and analog circuit components. Accordingly, control module 103 may also be referred to as an electronic module. Power supply module 104 typically comprises one or more energy storage devices, such as a rechargeable lithium ion battery. Recharge module 105 typically includes one or more coils for transmitting or receiving electromagnetic energy through the scalp. The transmitted energy may include energy to be stored in power supply module 104. In some embodiments, the transmitted energy may also include communication, such as information encoded in radio frequency transmissions.

[0039] Individual modules 103 and 104 may be encased in biocompatible metal shields such as titanium shield halves, and may be sealed against contamination. In addition, individual modules 103 and 104 may include insulation to electrically isolate the electrical components inside the modules from the metal shields. The modules are coupled to an overmold 106 which may be made of a biocompatible material. Use of the term "overmold" herein is not intend to limit the invention to embodiments in which the overmold is a molded structure. Overmold may be a molded structure, or may be a structure formed by any process. In addition, one or more coupling modules (not shown in FIG. 1A) may couple one or more modules to one another.

[0040] In some embodiments of the invention, overmold 106 encases all modules 103, 104 and 105. In other embodiments, overmold 106 is disposed over or around

the modules without encasing the modules. In further embodiments, overmold 106 acts as a "frame" to hold the modules in a fixed position relative to one another, but does not fully cover the modules. Some features of the overmold, and variations on the shape of the overmold, are presented below. In general, the shape of the overmold depends upon the arrangement of the modules. The overmold may be made of a variety of materials, such as flexible silicone. The overmold may also include a rigid polymer such as Ticothane surrounded by flexible silicone. The invention is not limited to these materials, however, and the overmold may comprise any combination of elastomeric and/or non-elastomeric materials.

[0041] FIG. 2 is a schematic diagram illustrating an IMD 201 according to another embodiment of the present invention. In this example embodiment, IMD 201 is arranged in a triangular configuration. IMD 201 includes three separate modules: a control module 210, a power source module 211, and a recharge module 212. These three modules are connected together to construct IMD 201. IMD 201 also contains a set of lead connection elements 213 that permit external leads to be connected to the control module 210 as needed. The triangular configuration of IMD 201 permit IMD 201 to possess a thin profile by spreading the modules over a larger surface area. In order to minimize the surface area compact, a triangular configuration is used. The configuration of IMD 201 may also be manipulated to conform to the shape of the location within a patient in which the device is being implanted. For example, implantation of IMD 201 under the scalp of a patient may be accomplished if the overall shape of IMD 201 is curved to follow the shape of a patient's skull. Any number of shapes may be used to match a particular IMD 201 to an implantation location for a device.

[0042] FIG. 3A and 3B are schematic diagrams illustrating an IMD 301 according to another embodiment of the present invention. In this embodiment of IMD 301, a flat device is shown that consists of multiple modules. This embodiment may be used in other locations within a patient in which the implantation location does not require such an exact match between the device and physical structures of the patient such as bone or muscle. IMD 301 may still be a modular device consisting of multiple modules as IMD 301 may provide a smaller profile when implanted as

to not protrude excessively once implanted. IMD 301 need not be rigid, and in some embodiments the orientation of the modules of IMD 310 may change relative to one another.

[0043] The flat embodiment shown in FIGS. 3A-3B may represent a device that may be a pectoral implant that may be used to treat angina, to provide vagal nerve stimulation, or to provide cardiac rhythm management. Similar devices may be implanted into an upper buttock implant location, into an abdomen location, and into periphery. A device implanted into an upper buttock location may be useful in a configuration for urological and gastrological implantation therapies. A device implanted into an abdomen location may be useful a configuration for providing pain, spasticity, and chemotherapy treatment. A device implanted into a periphery location may be useful a configuration for providing muscle stimulation, on-site nerve stimulation, and diaphragm stimulation therapies. These devices may both provide therapies as well as provide a platform for sensing conditions present within a patient.

[0044] Additional alternate embodiments for implantable medical devices implemented according to principles of the present invention may also include non-electrical based therapies such as targeted introduction of fluids and similar therapeutic agents using pumps and reservoirs.

[0045] FIGS. 4A-4F are schematic diagrams illustrating exemplary configurations and orientations of modules within IMD 401A through 401F (hereinafter 410), according to various embodiments of the present invention. IMD 401 consists of multiple modules that may be arranged into any number of orientations as shown in the various embodiments of FIGS. 4A-4F. For reference, each IMD 401 is depicted deployed proximate to the skull of a patient, with leads 402A and 402B deployed through burr holes 402A and 402B and coupled to IMD 401. The leads are coupled to the IMD via lead connection modules 415A and 415B. As shown in FIGS. 4A-4F, the lead connection modules may assume a variety of orientations relative to other components of IMD 401.

[0046] In each of these embodiments, IMD 401 has three modules as discussed above in reference to FIGS. 1B and 2: a control module 410, a power source module 411, and a recharge module 412. An overmold 413 at least partially covers

the housings of control module 410 and power source module 411. The modules may be arranged into a number of orientations as long as any interconnections between the modules may be routed within the device. The various embodiments include triangular configurations, as is shown in FIGS. 4A-4C, or linear configurations as shown in FIGS. 4D-4F. In FIG. 4D, one of the three modules, such as the recharge module, is deployed as a tethered module 414 rather than being covered by overmold 413.

[0047] The invention is not limited to the deployments of the lead connection modules shown in FIGS. 4A-4F. The lead connection modules may be located on various positions within IMD 401. Lead connection modules may be oriented, for example, to permit the leads to be routed to lead locations in an efficient manner or to support management of excess lead length. Any number of other orientations and alternate embodiments may be constructed according to principles of the present invention and consistent with the claims recited herein.

[0048] In each of the exemplary embodiments depicted in FIGS. 4A-4F, any two modules may be interconnected via one or more coupling modules (not shown in FIGS. 4A-4F). The particular coupling modules may depend upon the number of modules, the distance of the modules from one another, the amount of motion or displacement of one module from another, the expected direction or directions of displacement, whether the modules are arranged in a triangular, linear or other configuration, and so on.

[0049] FIGS. 5A-5C are schematic diagrams illustrating an exemplary construction of an overmold used in construction of an IMD according to the present invention. FIG. 5A illustrates that IMD 501 comprises a set of modules 510-512, a set of motion restriction elements, such as motion restriction fibers 521. In FIG. 5A, motion restriction fibers 521 are coupled to modules 510 and 511, and are covered at least in part by overmold 522. Overmold 522 typically includes a solid biocompatible material. Overmold 522 may comprise an elastomeric material that is soft and flexible, such as silicone. In addition or in the alternative, overmold 522 may comprise a non-elastomeric material that imparts rigidity to IMD 501. In one embodiment, for example, a non-elastomeric material in overmold 522 acts as a "frame" to hold the modules in a fixed position relative to

one another, and does not fully cover the modules. Overmold 522 covers, at least in part, the components and modules within IMD 501 while providing a flexible structure that permits the device 501 to conform to fit each individual patient. Because overmold 522 is typically flexible, IMD 501 may benefit from motion restriction devices such as motion restriction fibers 521, which provide structural integrity to device 501 once implanted into the patient.

[0050] FIG. 5B illustrates that the overmold 522 may include a non-elastomeric, or “hard” component 531 in addition to an elastomeric, or “soft” component 532. In FIG. 5B, the non-elastomeric component 531 is shaped to conform to the shape of at least one of modules 510-512 such that the modules may be restrained from motion by the non-elastomeric components. The non-elastomeric components 531 are typically made of a solid biocompatible material such as polysulfone, and may also be made of metal such as titanium.

[0051] The non-elastomeric components 531 are utilized in locations in which motion is to be restricted. Any or all modules may be constrained by one or more hard components 531. Overmold 522, including elastomeric and non-elastomeric components, can be fabricated into a single structure before the modules 510-512 are inserted into the device 501.

[0052] Generally, overmold 522 serves a number of functions. For example, overmold 522 incorporates motion restriction elements within the device 501, and attaches to modules and other elements to provide a unified device. In addition, overmold 522 provides a smooth interface surface for the device as it interacts with the patient, and protects electrical connections and feed through wires that connect modules to external leads.

[0053] Overmold 522 may also include a durometric specific material to provide desired device qualities such as flexibility and structural integrity. In addition, the material used to construct overmold 522 may possess a thermal conductivity characteristic to either act as a heat sink, or act as an insulator to shield the patient 100 from any excess heat from IMD 501. Because IMD 501 may be constructed from a large number of modules to perform a desired task, the materials selected for used in constructing the overmold 522 may vary as needed by each embodiment.

[0054] FIG. 5C illustrates that overmold 522 provides sloped interface 541 between an exemplary module 542 within IMD 501 and the patient's body. In embodiments in which IMD 501 is implanted within tight spaces, such as under the scalp of the patient, sloped interface 541 provides a smooth transition and eases sharp edges that are known to cause possible points of stress for tissue. An angle of interface from the patient's body and the sloped interface 541 can be approximately 135 degrees.

[0055] In the exemplary embodiments depicted in FIGS. 5A-5C, any two modules may be interconnected via one or more coupling modules (not shown in FIGS. 5A-5C). In addition to considerations identified above, the particular coupling modules may depend upon the configuration of the overmold, the configuration of elastomeric and non-elastomeric components; the presence of motion restriction devices, and so on.

[0056] FIGS. 6A-6C are schematic diagrams illustrating two distributed modules 610, 611 having a coupling module 612 according to an embodiment of the present invention. In FIGS. 6A-6C, coupling module 612 provides a single degree of freedom to move. In particular, coupling module 612 limits motion of modules 610, 611 relative to one another to a single axis.

[0057] IMD 601 shown in this embodiment is constructed from two individual modules 610-611 that are physically linked using a flexible coupling module 612 that may also be referred to as a "power pipe module." This coupling module possesses a coupling body having a connection end at each connection interface with a module. In a typical implementation, a coupling module 612 interfaces with a module by being coupled to a housing of the module. In each of the three embodiments shown in FIGS. 6A-6C, coupling module 612 constrains translational motion of one module relative to another. In FIGS. 6A-6C, coupling module 612 includes a flexible zone that is bendable.

[0058] In FIGS. 6A-6C, coupling module 612 is generally narrower than the dimensions of the modules 610-611. Furthermore, coupling module 612 may be constructed of a more flexible material than the modules, resulting in some freedom of bending. In FIG. 6A, coupling module 612 is depicted as a distinct module coupled to two modules. In FIGS. 6B and 6C, by contrast, coupling

module 612 forms part of a unified structure with modules 610 and 611. FIG. 6B illustrates the coupling module 612 as including a narrow zone between two compartments of a common structure, with a module deployed within each of the two compartments 610-611. FIG. 6C shows the coupling module 612 as including a distinctly separate ribbed element that separates the two modules 610-611 and that accommodates some motion of the modules relative to one another.

[0059] With the freedom provided by coupling module 612, modules 610-611 may be oriented relative to one another, such that IMD 601 as a whole includes a convex surface. Coupling module 612 may be semi-rigid to permit the IMD 601 to be manipulated into a desired shape and then retain modules 610-611 in a desired orientation. Alternatively, coupling module 612 may flexibly permit modules 610-611 to move freely about an axis of rotation 613.

[0060] Coupling module 612 defines at least one lumen or passageway. This lumen (not shown in FIGS. 6A-6C) permits components and elements in one module 610 to be mechanically or electrically coupled to other components and elements in the other module 611. Coupling module 612 provides a structural support element that protects these connections between modules from damage. Coupling module 612 may also include one or more hermetic interfaces between a module and coupling module 612 to environmentally protect the modules 610-611 from contamination. In some embodiments, coupling module 612 is hermetically fixed to at least one of the housings of modules 610-611. In other embodiments of the invention, coupling module 612 may be fixed to one or more modules non-hermetically.

[0061] FIGS. 7A-7B are schematic diagrams illustrating two distributed modules having a coupling module with at least two degrees of freedom to move, according to an embodiment of the present invention. IMD 701 shown in these embodiments includes two modules 710-711 that are physically linked using a coupling module 721 that may typically possess two degrees of motion. In each of the three exemplary embodiments shown in FIGS. 7A-7C, a flexible coupling module 721 exists between the two modules 711-712.

[0062] In these embodiments, the flexible coupling module 721 may flex about two axis of rotation that correspond to dimensions of the of coupling module 721

that are most narrow. Coupling module 721 may rotate in a pitch and yaw axis, for example, but not in a roll axis.

[0063] In FIG. 7B, IMD 701 includes a third module 713 coupled to another module 711 via a second coupling module 722. Coupling module 722, like coupling module 721, may support two axes of motion. As a result, the individual modules 711, 712, 713 may be oriented relative to one another in three dimensions. Coupling module 722, like coupling module 721, may be hermetic or non-hermetic. Coupling modules 721 and 722 may have, but need not have, comparable degrees of flexibility.

[0064] FIG. 8 is schematic diagram illustrating an IMD 801 having two distributed modules 811, 812 with a coupling module 821 that affords three degrees of freedom to move, according to an embodiment of the present invention. In FIG. 8, modules 811-812 are physically linked with coupling module 821. Coupling module 821 affords some freedom to orient modules 811-812 so that modules 811-812 are not co-planar. Modules 811 and 812, may be moved closer or farther apart by flexing coupling module 821 at bend 831A or bend 831B, or both. Modules 811 and 812, may also be twisted relative to one another by bending or twisting elongated section 832. In the embodiment shown in FIG. 8, module 811 includes a notched connection point 833 that enables an enhanced range of motion.

[0065] The degree of motion is a function of the configuration of the coupling module, such its length or the number and placement of bends, and the material from which the coupling module is constructed. In one embodiment, the coupling module is formed of titanium. Other materials, such as silicone, other metals such as stainless steel, or polymers such as polysulfone, may also be used to construct the coupling module. Moreover, a coupling module may be constructed from more than one material. In general, a coupling module should be durable and reliable, and should be subject to bending or twisting without damage.

[0066] FIG. 9 is schematic diagram illustrating an IMD 901 with two distributed modules 911 and 912 and a coupling module 921 having both a non-hermetic boundary 931 and a hermetic boundary 932. In this embodiment, the boundary between module 911 and coupling module 921 is non-hermetic. In contrast, the boundary between module 912 and coupling module 921 is hermetic. Such an

arrangement may make the fabrication of IMD 901 simpler as it eliminates a hermetic interconnection boundary that imposes cost, complexity and size limitations. In some circumstances, hermetic sealing of module components is unnecessary.

[0067] The nature of the hermetic interfaces above described refer to the interfaces between modules and the coupling modules. As such, the overall device 901 may possess no hermetic interfaces between these modules, and may permit passage of liquid or gaseous material between modules, while the entire structure of IMD 901 remains hermetically sealed from the patient. In another embodiment, one module, such as a non-hermetic battery may be enclosed within a hermetically sealed module that does not permit battery material to pass into a coupling module and any other modules. In this embodiment, the entire device 901 may also be hermetically sealed from the patient. In a third embodiment, the various interfaces between all modules and a particular coupling module may possess hermetic interfaces while the coupling module itself is not hermetically sealed to the patient. As such, a coupling module containing an AC power connection between modules may not require a hermetically sealed coupling module with respect to the patient.

[0068] In addition, the lumen defined by coupling module 921 need not be empty or filled with air. In some embodiments, coupling module 921 may be back filled with fluids and other materials. Such materials may, for example, offer some isolation of components disposed in the coupling module, or may insulate, or may dissipate heat, or may absorb gases that may be emitted by a battery in a power supply module.

[0069] FIGS. 10A-10I are schematic diagrams illustrating exemplary coupling module shapes and configurations according to embodiments of the present invention. Coupling module 1001 provides a protected interconnection volume between two modules within a modular IMD. The particular shape for the coupling module 1001 may be affected by the nature of the interconnection between the two modules, the orientation of the modules, the size of the lumen, the desired degree of flexibility, and the like. One generally desirable characteristic of the coupling module is that it be flexible enough to accommodate some motion of the modules relative to one another without becoming damaged. Some

embodiments of coupling module 1001 may also provide structural protection and support for the module interconnection.

[0070] FIGS. 10A-10C illustrate a coupling module 1001 having a single lumen connecting two modules. FIG. 10A illustrates a round or circular lumen. FIG. 10B illustrates a semi-circular lumen. FIG. 10C illustrates a rectangular lumen. The invention is not limited to a lumen having any particular cross-section, and includes coupling modules having cross-sections not specifically shown herein.

[0071] FIG. 10D illustrates a coupling module 1001 that possesses a bellows section 1002 as part of its structure. Bellows 1002 enhances the flexibility of coupling module 1001. In particular, the embodiment of coupling module 1001 depicted in FIG. 10D illustrates a coupling module that includes variations in the cross-sectional diameter that accommodate motion along one or more axes of motion. The bellows configuration in FIG. 10D is illustrative, and the invention includes embodiments that comprise corrugations, convolutions, or other variations in cross-sectional shape that impart degrees of freedom of movement.

[0072] FIG. 10E illustrates that a coupling module 1001 of any configuration discussed herein may include multiple lumens. The lumens may provide independent interconnection paths that are separate from each other. These multiple lumens permit the coupling module to provide connections that are isolated from one other. In FIG. 10E, lumens 1003A and 1003B are side-by-side. FIG. 10F illustrates a coupling module 1001 having coaxial lumens. In FIG. 10F, the lumens include an inner conductor 1004A and an outer conductor 1004B separated from inner conductor 1004A by a dielectric 1005, such that coupling module is similar to a coaxial cable. In some embodiments, the lumens of a coaxial coupling module need not include conductors or dielectrics. The invention encompasses embodiments in which lumens are configured in a concentric fashion.

[0073] FIG. 10G illustrates a coupling module 1001 that is a ring-like structure having a plurality of separate conduit segments around the ring. FIG. 10H illustrates another concentric arrangement for conduits in which an inner conduit 1010 is separated from an outer conduit 1011. Finally, FIG. 10I illustrates that a coupling module may be arranged to include a helix-like structure. A helix-like

structure may, for example, tend to permit more motion along some axes and less motion along others.

[0074] In some embodiments of the invention, a coupling module may include a combination of features shown in FIGS. 10A-10I. For example, a coupling module may include a straight portion and a helical portion, or multiple lumens and a bellows section. The invention encompasses all of these combinations.

[0075] FIGS. 11A-11M are schematic diagrams illustrating configurations of multiple modules having a coupling module interconnecting two modules according to embodiments of the present invention. FIGS. 11A-11M illustrate various arrangements of interconnected modules used to construct an IMD. These arrangements illustrate some of arrangements for in-line and triangular configurations of the modules. These arrangements illustrate use straight and helix-like arrangements of the coupling modules. Finally, these arrangements illustrate interconnection of modules from adjacent module surfaces or sides as well as interconnection of non-adjacent sides of modules.

[0076] Combination of various features gives rise to the exemplary arrangements shown in FIGS. 11A-11H. In particular, coupling module 1101 may include a combination of straight, curved or helical sections when coupling module 1110 to module 1111. FIGS. 11I and 11J illustrate more rigid coupling module 1101 arrangements between adjacent sides of two modules 1110-1111. FIG. 11K illustrates that a coupling module 1101 may connect two modules 1110-1111 by bending around a third module 1112. Finally, FIGS. 11L-11M illustrate the interconnection of two modules 1110-1111 using an S-shaped coupling module 1101. Embodiments in FIGS. 11L-11M include any arrangement and shape for a connection body used to construct a coupling module possessing at least one non-linear bend.

[0077] The invention is not limited to the particular coupling module configurations shown herein. The possible arrangements of IMD modules and coupling modules is virtually unlimited.

[0078] FIGS. 12A-12C are schematic diagrams illustrating module interfaces with a coupling module according to an embodiment of the present invention. FIGS. 12A-12B illustrate construction of two distributed modules from case components

1201-1202, module end caps 1211-1212, and a flexible interconnection coupling module 1222. The module end caps 1211-1212, and a flexible interconnection coupling module 1222 are mechanically coupled using weld joints 1231-1232. The module end caps 1211-1212 may be coupled to case components 1201-1202 with welds or braze joints. As is discussed above, these connections may be either hermetic, as shown, or non-hermetic. FIG. 12C illustrates a completed module end cap and coupling module assembly 1241 that may be further coupled to two modules (not shown) to construct a modular IMD.

[0079] FIG. 13 is a schematic diagram illustrating the degrees of motion present in a multi-module IMD. For any two modules within a modular medical device, motion between the two devices may be defined in terms of pitch motion 1301 (shown in side view), yaw motion 1302 (shown in top view), and roll motion 1303 (shown in end view). For the set of motion restriction elements (not shown) discussed above, all three degrees of motion may be limited to prevent mechanical failures of interconnections between the modules during use of an IMD.

[0080] FIGS. 14A-14C are schematic diagrams illustrating motion restriction within various degrees of motion within a multi-module IMD. For any two modules 1401-1402 within an IMD, motion restriction elements 1422-1423 may be employed to constrain the relative orientation of modules 1401-1402. Motion restriction elements 1422-1423 may be sufficient to restrain motion, thereby reducing the risk of potentially damaging stress upon a coupling module. In some embodiments, motion restriction elements 1422-1423 are typically successful in adequately restricting motion in one or two degrees of motion. These degrees of motion are typically along an axis in which the elements 1422-1423 possess most of their strength. For example, motion restriction elements 1422-1423 may constrain motion along a yaw and pitch axis but provide little or no constraint along the roll axis.

[0081] FIG. 14A illustrates an embodiment in which the motion restriction elements 1422-1423 include one or more physical members that physically interact to restrain motion. FIG. 14B illustrates an embodiment in which the motion restriction elements 1422-1423 include one or more wire loops that oppose each other to restrain motion. FIG. 14C illustrates an embodiment in which the motion

restriction elements 1422-1423 include a fabric that physically restrains motion. In alternate embodiments, motion restriction elements may be used to constrain motion along one or all axes.

[0082] FIGS. 15A-15B are schematic diagrams illustrating an exemplary interaction of components of an IMD that are part of an overmold 1522, which includes one or more soft or elastomeric components 1532 and one or more hard or non-elastomeric components 1531, which interface with a control module 1510. Non-elastomeric component 1531 may be shaped to mate with the module 1510 to provide motion restriction for the module. Non-elastomeric component 1531 may be mechanically connected to other modules using a motion restriction element(not shown). The overmold 1522 covers all of these components in this embodiment. A through hole 1551 may be located through the through the non-elastomeric component 1531 and elastomeric component 1532 to provide an attachment point for the device 1501. In some embodiments, IMD 1501 may be anchored in place using bone screws or other anchoring devices. Through holes 1551 permit IMD 1501 to be mechanically anchored to the patient once the device 1501 is positioned at a desired location. In the embodiment shown in FIG. 15A, a bone screw inserted into through hole 1551 would seat against non-elastomeric component 1531, but the invention encompasses embodiments in which a bone screw would seat against another component, such as control module 1510..

[0083] FIG. 15B illustrates a top view of the device 1501 having elastomeric component 1532 of overmold 822 covering the non-elastomeric components 1531 that frame control module 1510. The through hole 1551 used as an attachment point is shown as part of non-elastomeric component 1531 that is covered by elastomeric component 1532. The shape of non-elastomeric component 1531 and control module 1510 are shown as being rectangular in this embodiment. However, one skilled in the art will recognize that any shape for non-elastomeric component 1531 and control module 1510 may be used.

[0084] In addition, overmold 1522 is shown in FIGS. 15A and 15B as substantially or completely encapsulating module 1510. However, overmold 1522 may also merely surround the module 1510 but not cover the top of the module that is

surrounded by the hard component 1531. Such an arrangement may result in a smaller profile of the overall IMD.

[0085] A coupling module (not shown) passes around and through many of the elements of the overmold. This coupling module may be, but need not be, constrained within overmold 1522. In general, the coupling module may be expected to flex during implantation and use. In some embodiments of the invention, the coupling module may be routed in a channel (not shown) within the overmold.

[0086] FIGS. 16A-16B are schematic diagrams illustrating a multi-module IMD 1601 having a triangular module arrangement according to the present invention. FIG. 16A illustrates an exploded view of IMD 1601. FIG. 16B illustrates a perspective view of IMD 1601. In this embodiment, another triangular arrangement of modules is shown with an overmold 1622 covering or at least partially encapsulating the modules. In this embodiment, overmold 1622 comprises a distinct slope interface 1641 that surrounds the periphery of IMD 1601. In this embodiment, slope interface 1641 is shown as a separate physical structure, such as a flexible band or ring. A coupling module 1651 is shown connecting two modules 1610-1611 without being restrained by the overmold 1622.

[0087] While the above embodiments of the present invention describe a coupling module of a modular IMD, one skilled in the art will recognize that the use of a module structure are merely example embodiments of the present invention. Although the dimensions of different embodiments of coupling modules may vary, the dimensions of typical coupling modules are such that the coupling module need not be responsible for the thickest portion of the IMD.

[0088] As such, the foregoing description of the exemplary embodiments of the invention has been presented for the purposes of illustration and description. They are not intended to be exhaustive or to limit the invention to the precise forms disclosed. Many modifications and variations are possible in light of the above teaching.

CLAIMS

WHAT IS CLAIMED IS:

1. An implantable medical device comprising:
at least two modules, each of the modules comprising a housing; and
a coupling module coupled to each of the modules, the coupling module
defining at least one lumen between the modules,
wherein the coupling module permits motion of the two modules along at
least one axis of motion.
2. The implantable medical device of claim 1, further comprising an overmold
that at least partially encapsulates each of the housings and the coupling module.
3. The implantable medical device of claim 1, wherein the coupling module
permits motion of the two modules along at least two axes of motion.
4. The implantable medical device of claim 1, wherein the coupling module
defines at least two lumens.
5. The implantable medical device of claim 4, wherein the lumens comprise
co-axial lumens.
6. The implantable medical device of claim 1, wherein at least one of the two
modules comprises a control module containing electronic components.
7. The implantable medical device of claim 1, wherein the implantable
medical device has a maximum thickness of between approximately 4 millimeters
and approximately 8 millimeters.

8. The implantable medical device of claim 1, wherein the coupling module defines one of a circular cross-sectional shape, a semi-circular cross-sectional shape and a rectangular cross-sectional shape.
9. The implantable medical device of claim 1, wherein the coupling module is hermetically fixed to at least one of the first and second housings.
10. The implantable medical device of claim 1, wherein the coupling module includes a bellows section.
11. The implantable medical device of claim 1, wherein the coupling module includes at least a helical portion.
12. The implantable medical device of claim 1, wherein the coupling module is made of metal.
13. The implantable medical device of claim 1, wherein the coupling module is fixedly coupled to at least one housing with a weld joint.
14. The implantable medical device of claim 1, further comprising:
 - a third module; and
 - a second coupling module fixedly coupled to the third module and to at least one of the first and second housings.
15. The implantable medical device of claim 1, wherein the coupling module is fixedly coupled to portions of the housings that are adjacent to one other.
16. The implantable medical device of claim 1, wherein the coupling module comprises at least one bend.
17. The implantable medical device of claim 1, further comprising a conductor passing through the lumen that electrically couples the first and second modules.

1/18

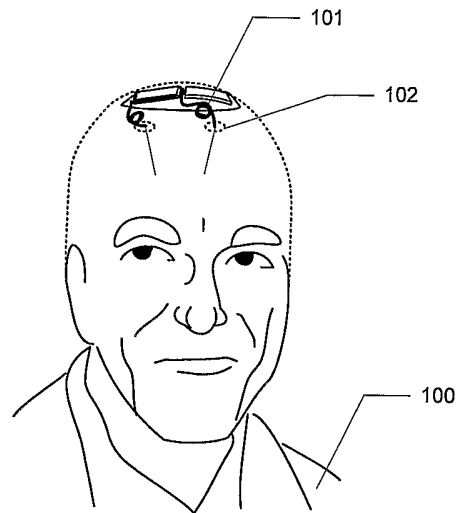

FIG. 1A

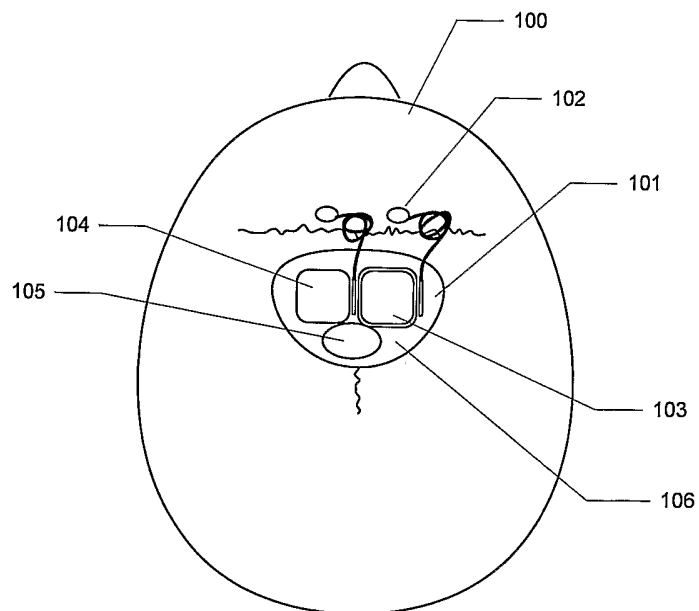

FIG. 1B

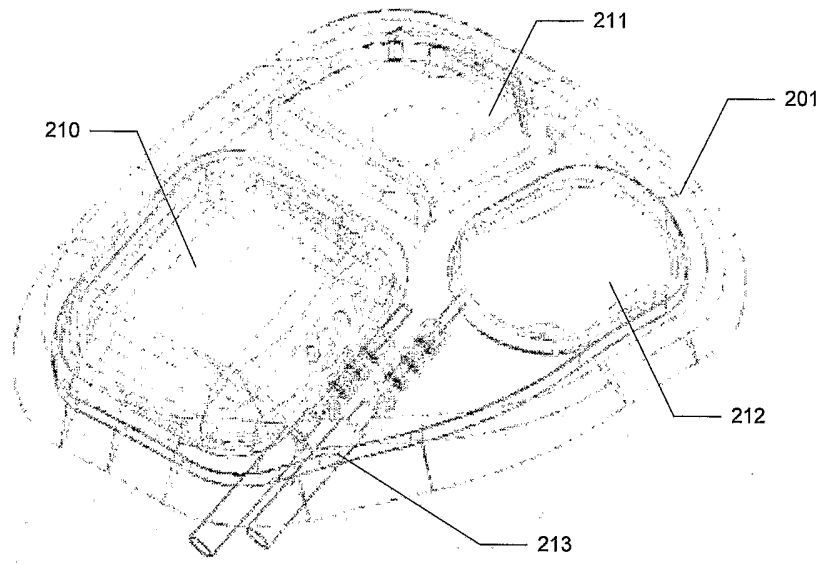

FIG. 2

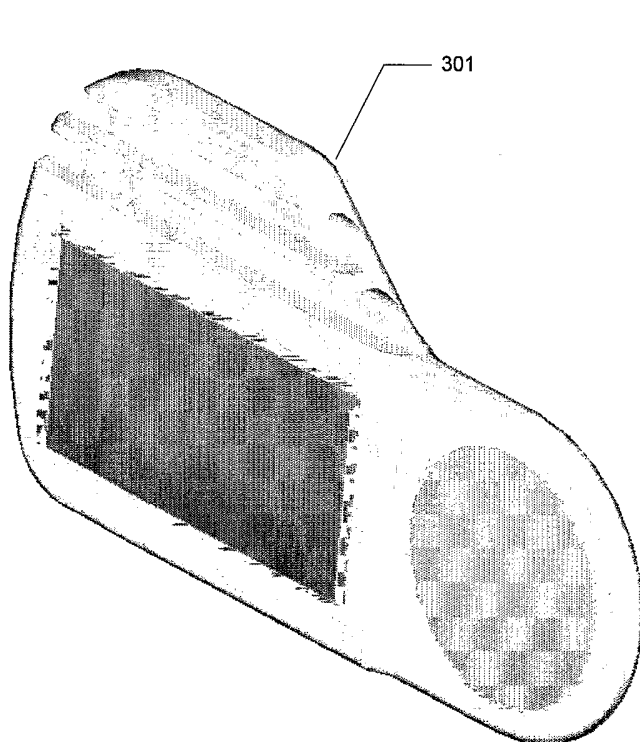

FIG. 3A

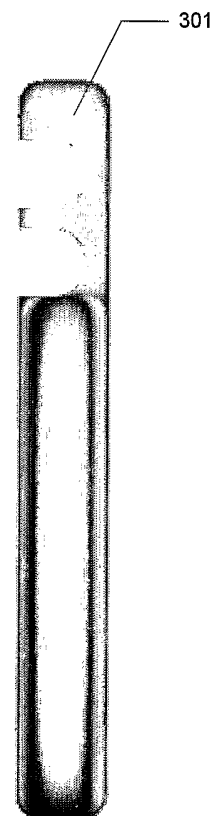

FIG. 3B

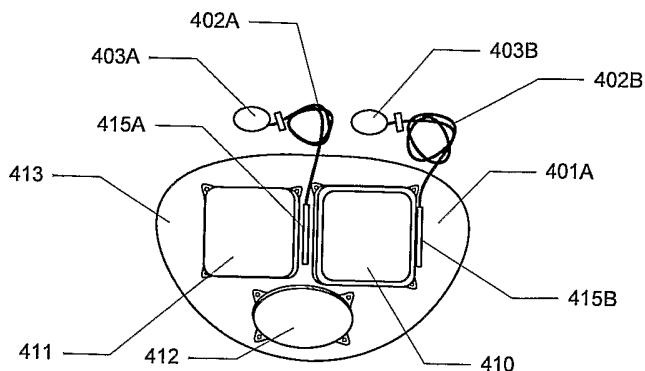

FIG. 4A

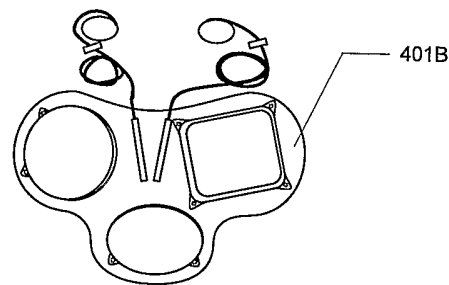

FIG. 4B

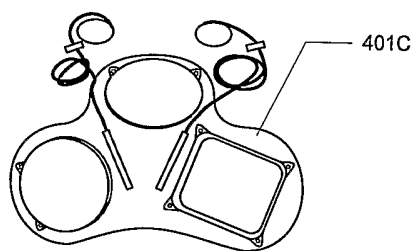

FIG. 4C

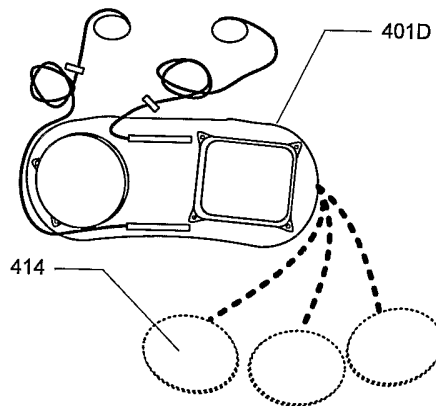

FIG. 4D

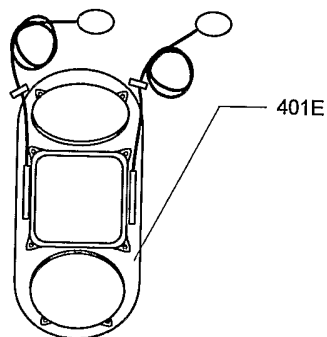

FIG. 4E

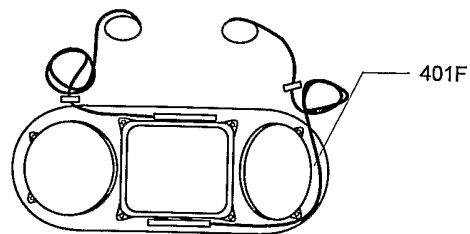

FIG. 4F

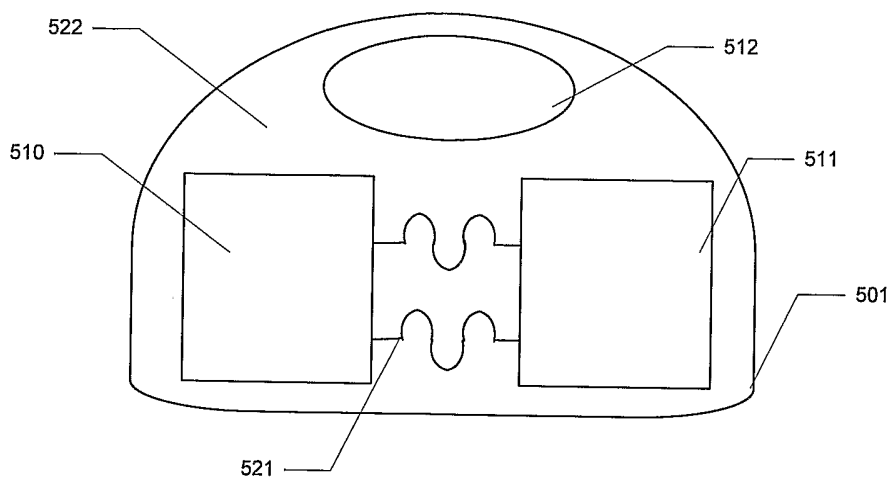

FIG. 5A

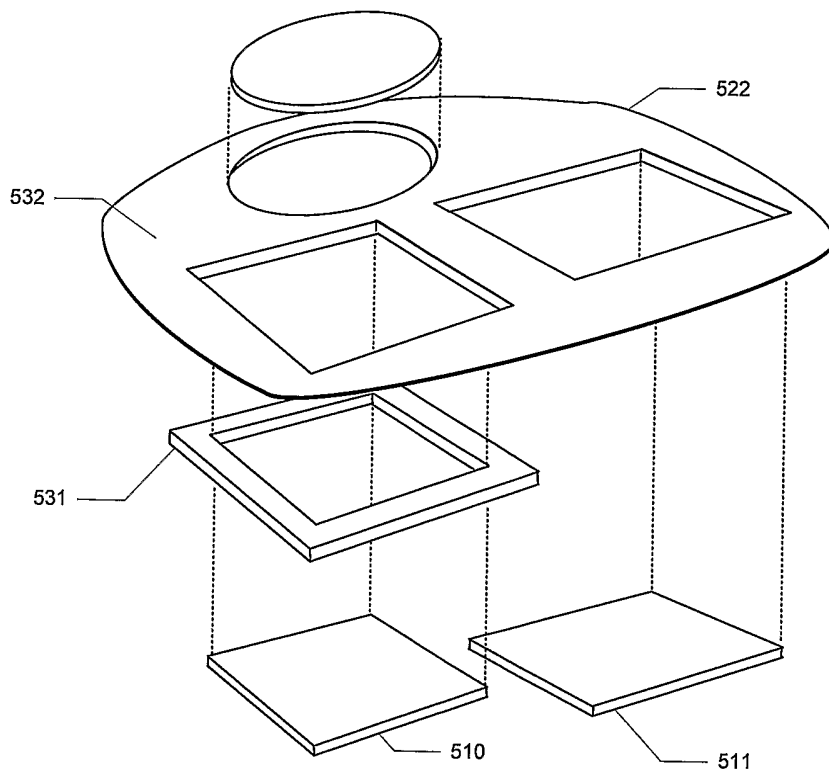

FIG. 5B

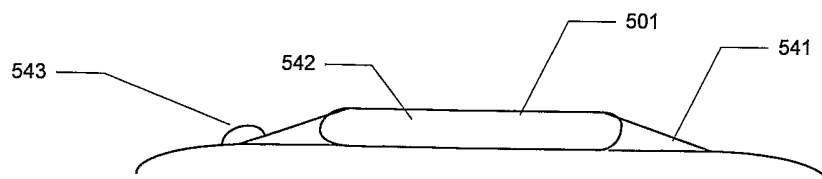

FIG. 5C

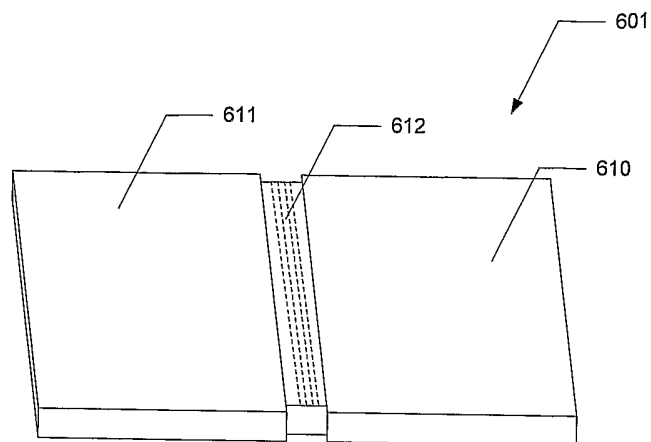

FIG. 6A

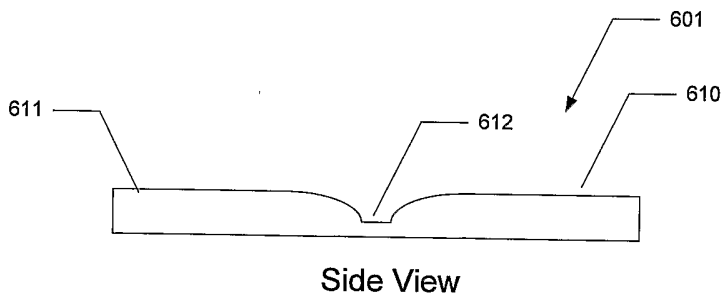

FIG. 6B

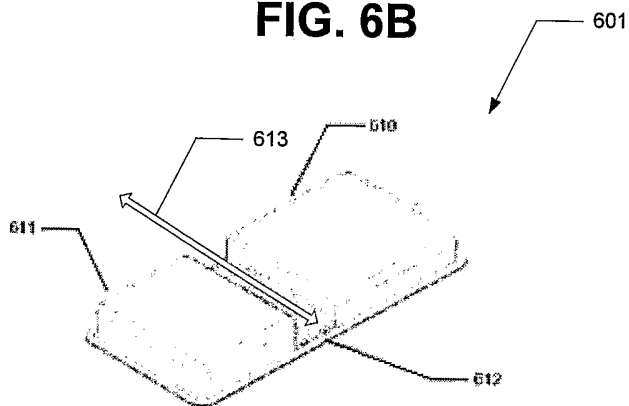

FIG. 6C

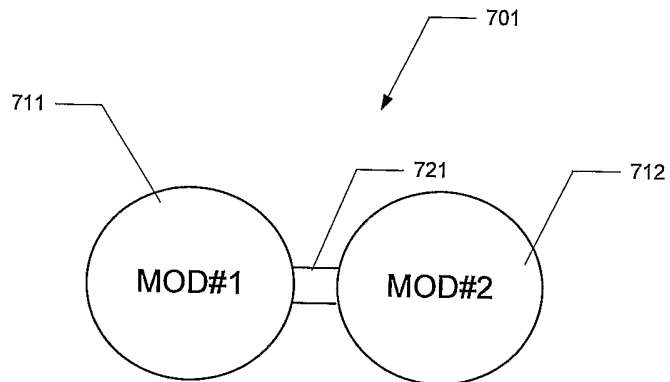

FIG. 7A

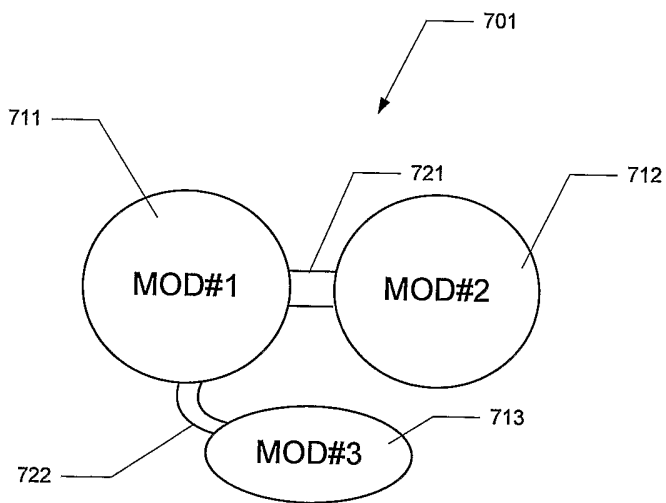

FIG. 7B

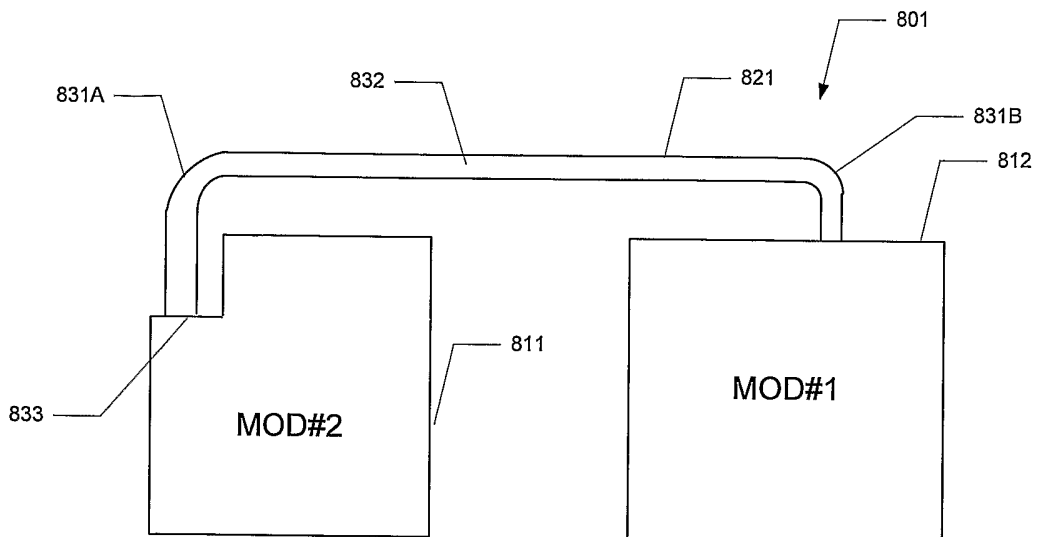

FIG. 8

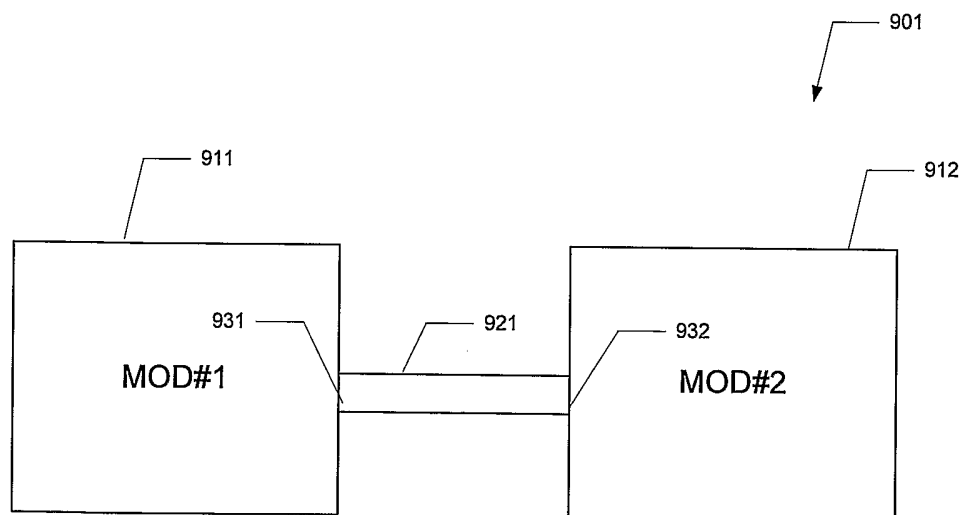

FIG. 9

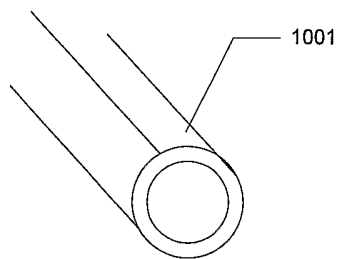

FIG. 10A

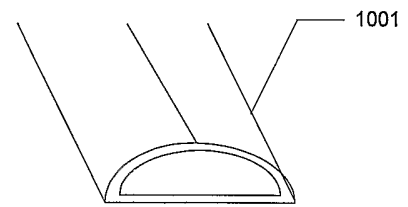

FIG. 10B

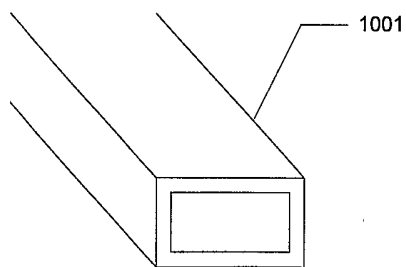

FIG. 10C

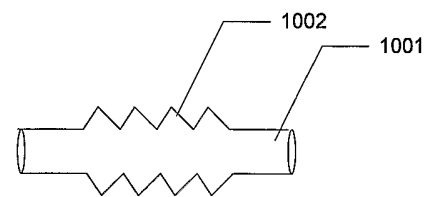

FIG. 10D

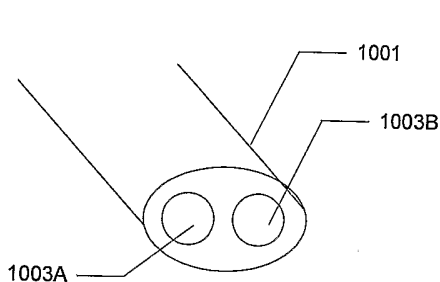

FIG. 10E

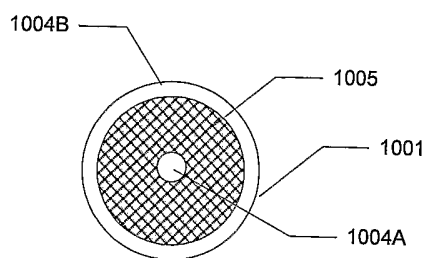

FIG. 10F

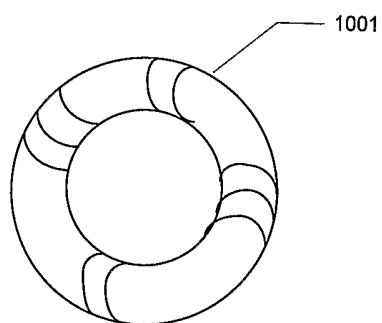

FIG. 10G

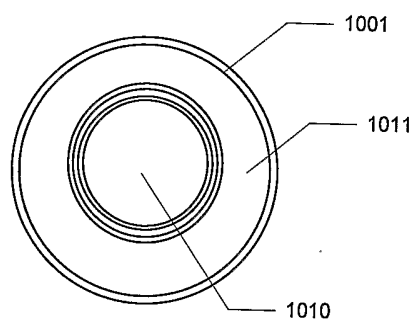

FIG. 10H

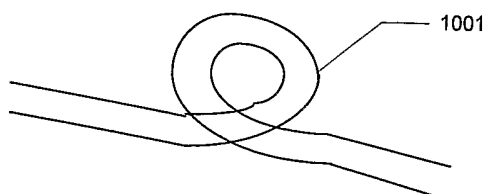

FIG. 10I

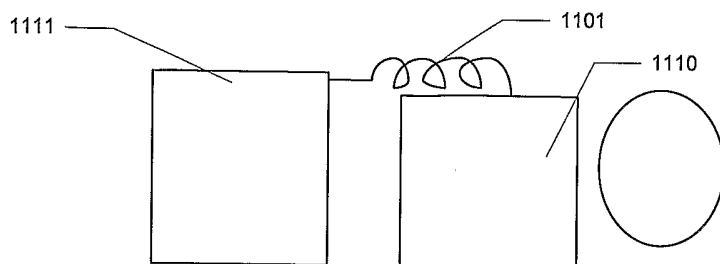

FIG. 11A

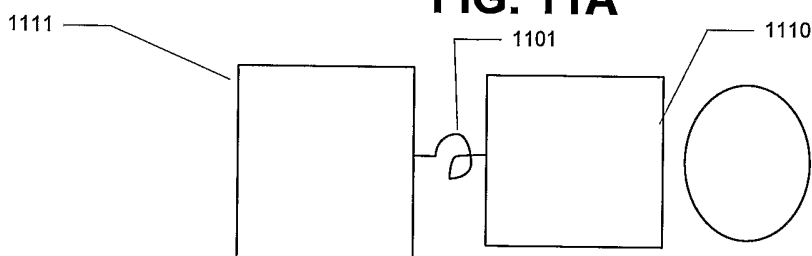

FIG. 11B

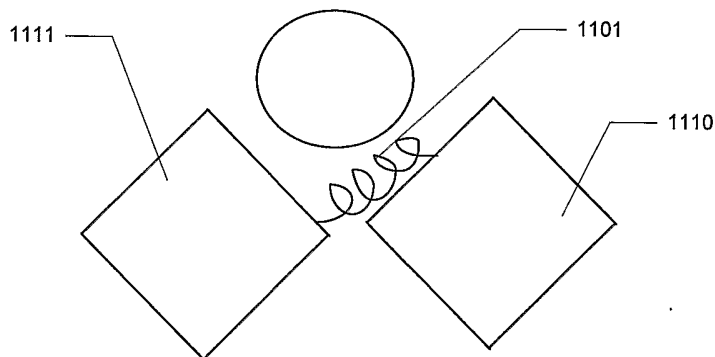

FIG. 11C

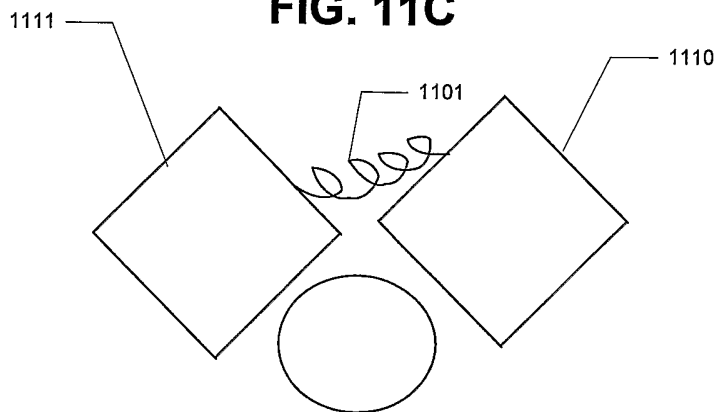
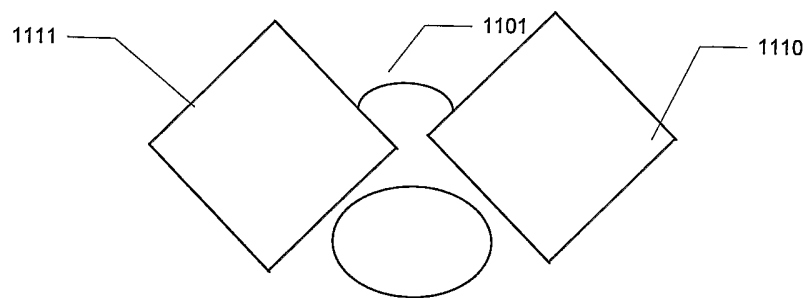
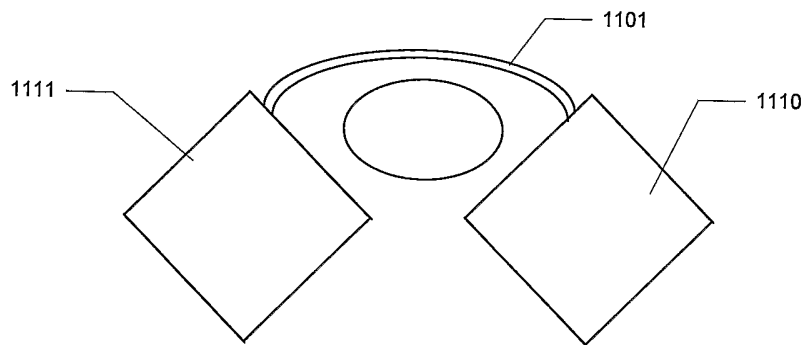
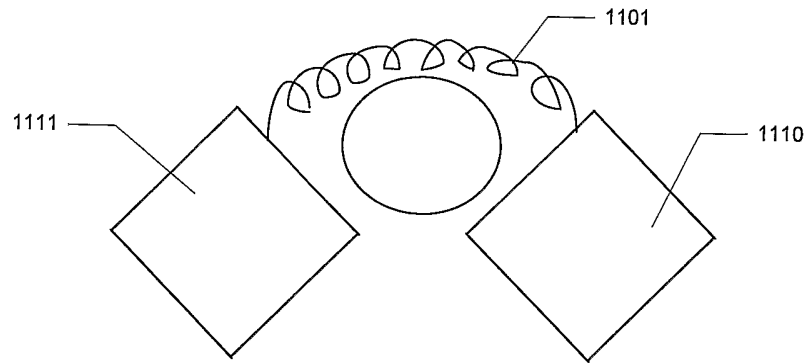

FIG. 11D

11/18



12/18

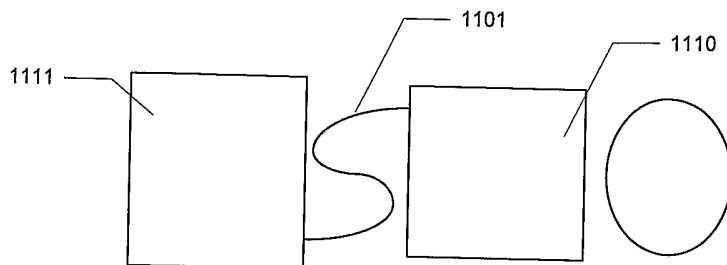

FIG. 11H

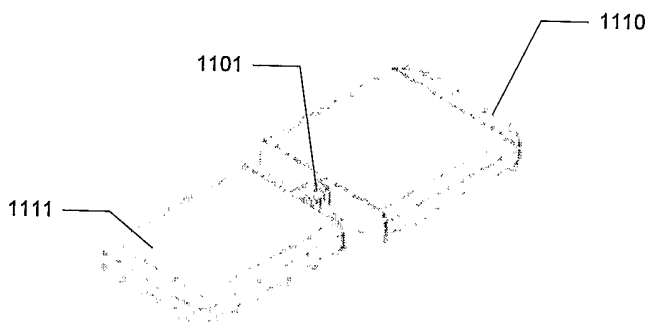

FIG. 11I

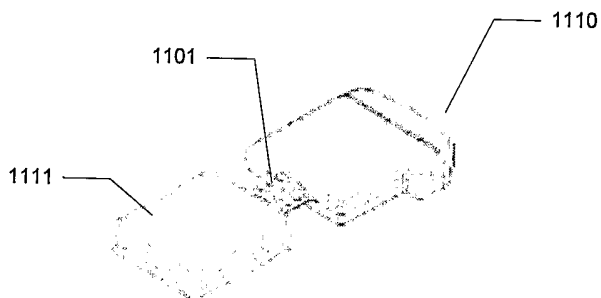

FIG. 11J

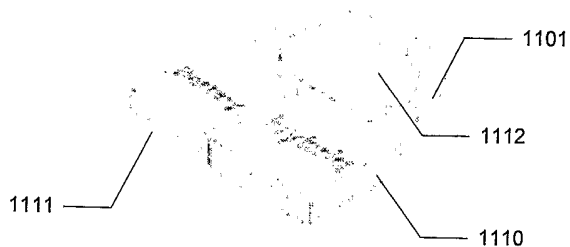

FIG. 11K

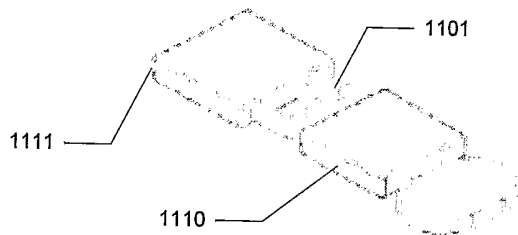

FIG. 11L



FIG. 11M

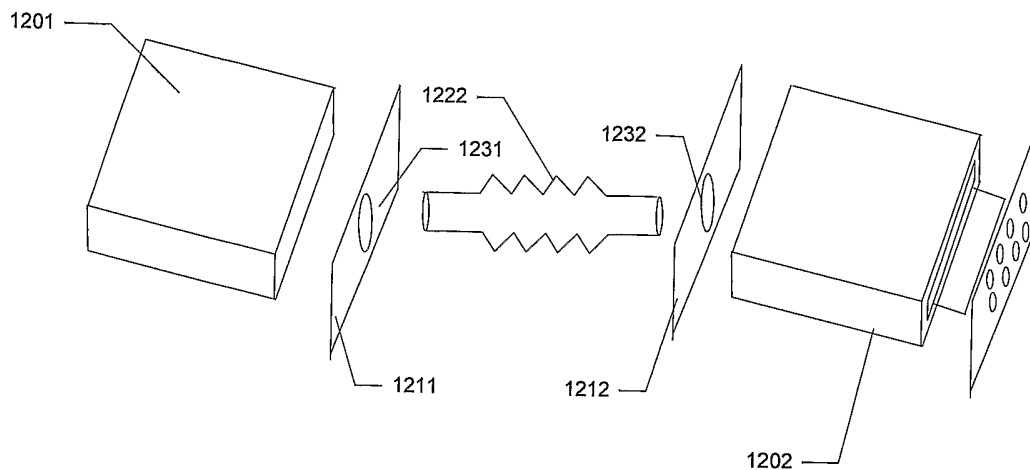

FIG. 12A

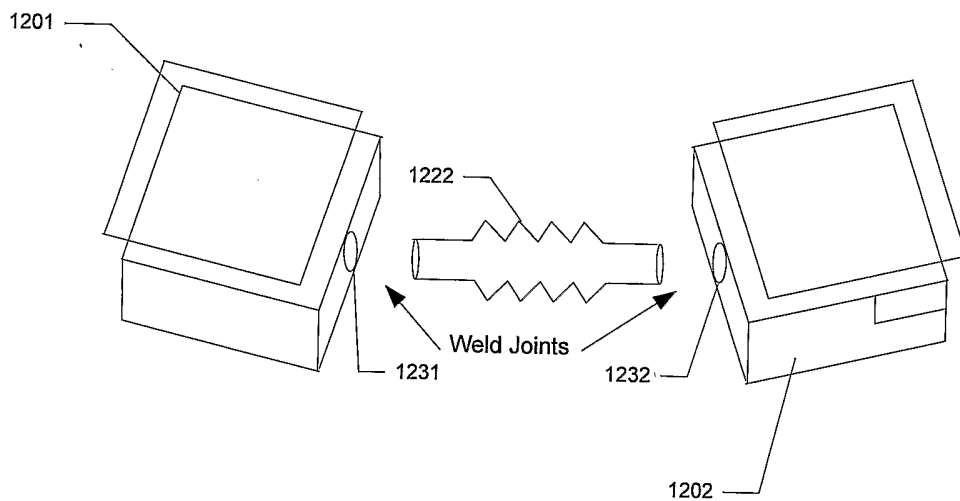

FIG. 12B

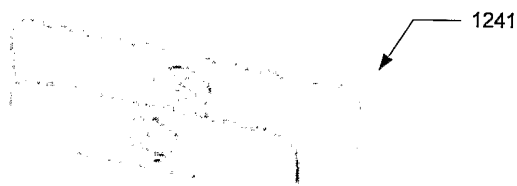

FIG. 12C

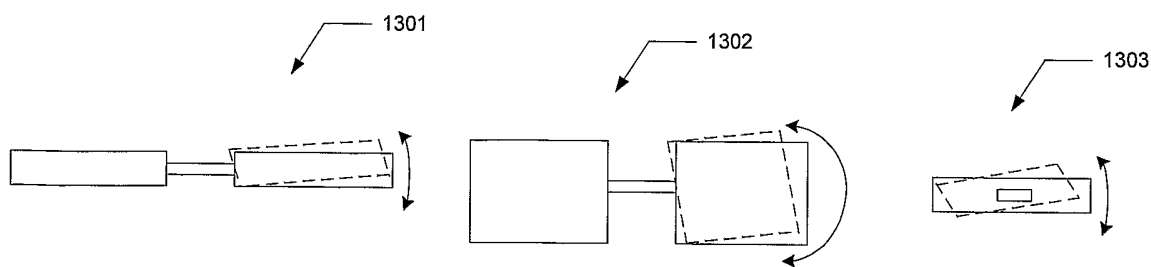

FIG. 13

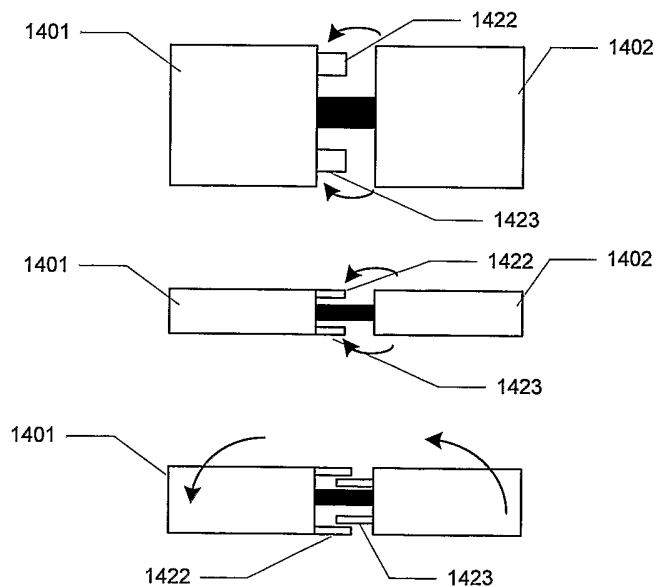

FIG. 14A

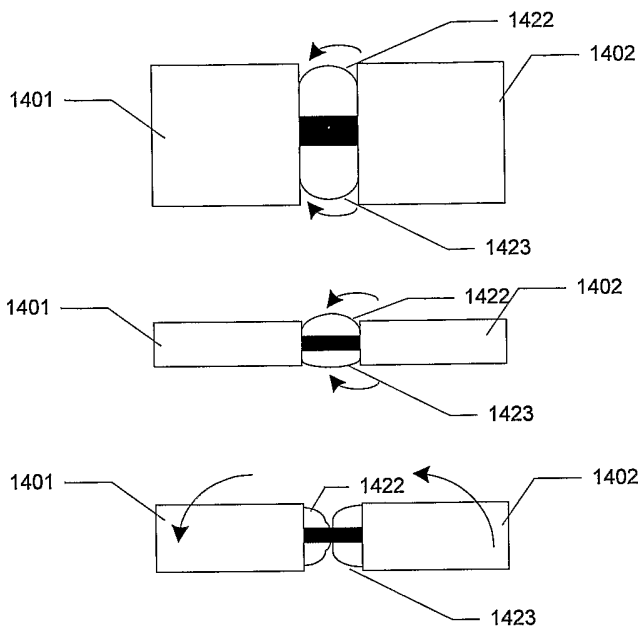

FIG. 14B

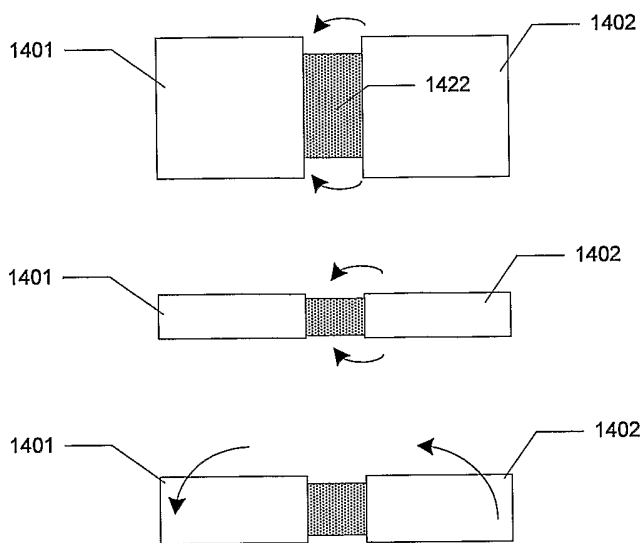

FIG. 14C

17/18

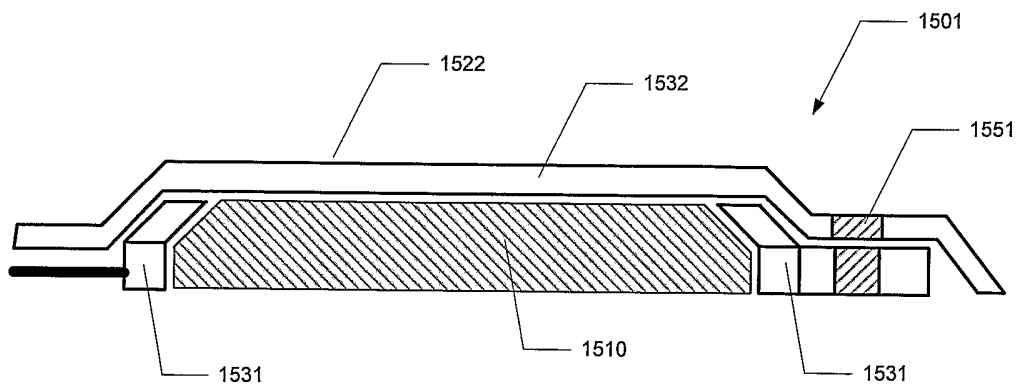

FIG. 15A

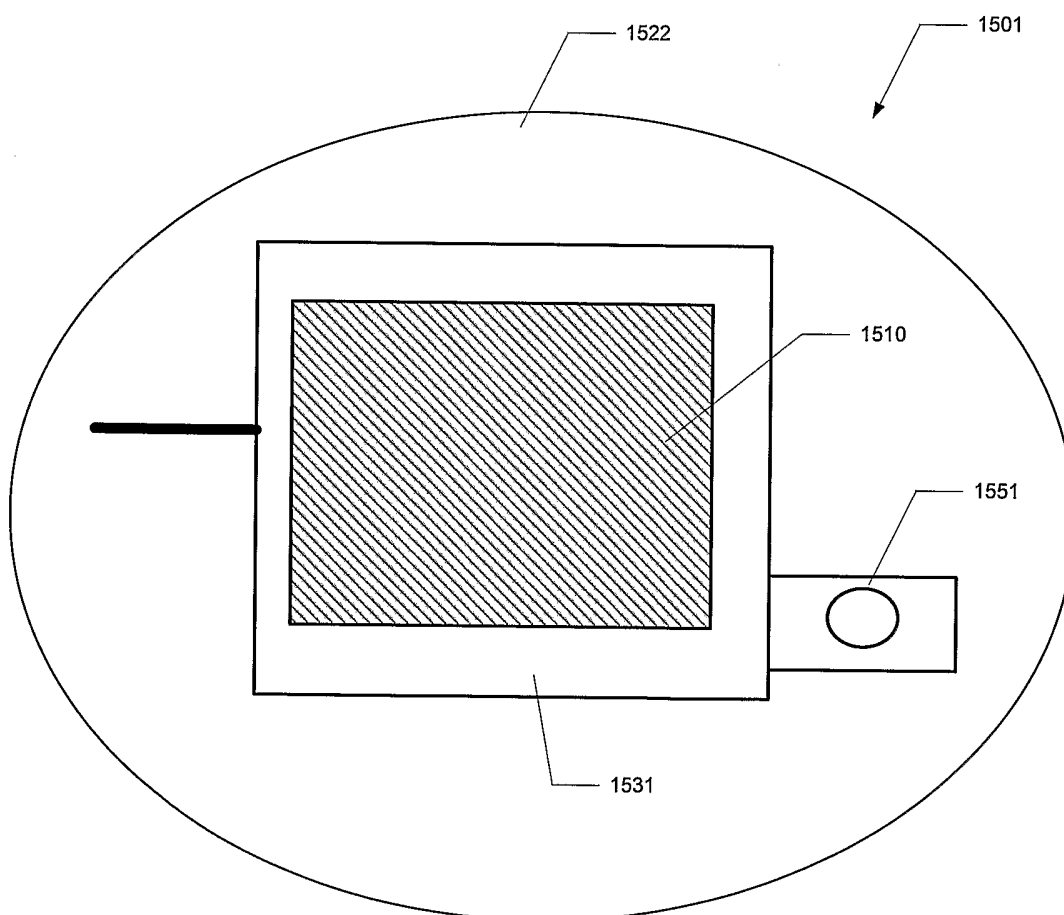

FIG. 15B

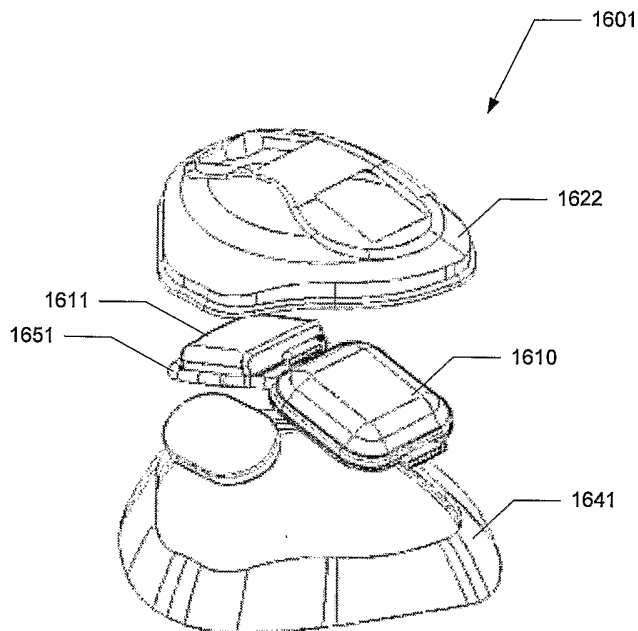

FIG. 16A

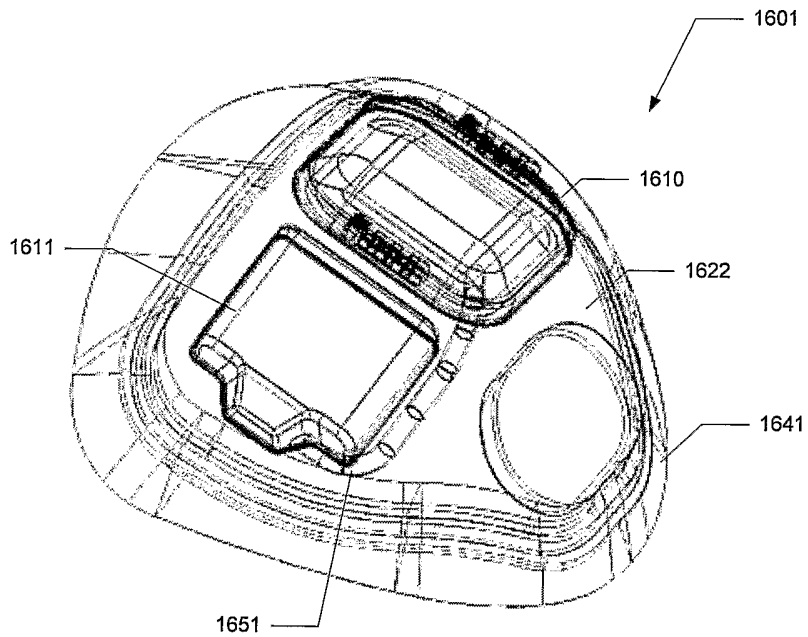

FIG. 16B

INTERNATIONAL SEARCH REPORT

In ternational Application No
PCT/US 03/38938

A. CLASSIFICATION OF SUBJECT MATTER IPC 7 A61N1/375 A61N1/36		
According to International Patent Classification (IPC) or to both national classification and IPC		
B. FIELDS SEARCHED		
Minimum documentation searched (classification system followed by classification symbols) IPC 7 A61N A61B		
Documentation searched other than minimum documentation to the extent that such documents are included in the fields searched		
Electronic data base consulted during the international search (name of data base and, where practical, search terms used) EPO-Internal, WPI Data		
C. DOCUMENTS CONSIDERED TO BE RELEVANT		
Category °	Citation of document, with indication, where appropriate, of the relevant passages	Relevant to claim No.
X A	US 6 358 281 B1 (BERRANG PETER G ET AL) 19 March 2002 (2002-03-19) column 2, line 28 -column 14, line 53; figures 1-6,15-18 ---	1-4, 6-10,12, 14-17 5,11,13
X A	US 6 308 101 B1 (GORD JOHN C ET AL) 23 October 2001 (2001-10-23) column 9, line 7 -column 14, line 19 column 18, line 14 -column 19, line 61; figures 1D-F,3A-B,4A-B,6,7,9A-B,10A-B ---	1-4,6-9, 12,14-17 5,10,11, 13
X A	US 2002/051550 A1 (LEYSIEFFER HANS) 2 May 2002 (2002-05-02) p. 4, '0045! - p. 6, '0065! ---	1-4,6-9, 12,14-17 5,10,11, 13
	-/--	
<input checked="" type="checkbox"/> Further documents are listed in the continuation of box C.		
<input checked="" type="checkbox"/> Patent family members are listed in annex.		
° Special categories of cited documents :		
A document defining the general state of the art which is not considered to be of particular relevance *E* earlier document but published on or after the international filing date *L* document which may throw doubts on priority claim(s) or which is cited to establish the publication date of another citation or other special reason (as specified) *O* document referring to an oral disclosure, use, exhibition or other means *P* document published prior to the international filing date but later than the priority date claimed *T* later document published after the international filing date or priority date and not in conflict with the application but cited to understand the principle or theory underlying the invention *X* document of particular relevance; the claimed invention cannot be considered novel or cannot be considered to involve an inventive step when the document is taken alone *Y* document of particular relevance; the claimed invention cannot be considered to involve an inventive step when the document is combined with one or more other such documents, such combination being obvious to a person skilled in the art. *&* document member of the same patent family		
Date of the actual completion of the international search 28 April 2004		Date of mailing of the international search report 07/05/2004
Name and mailing address of the ISA European Patent Office, P.B. 5818 Patentlaan 2 NL - 2280 HV Rijswijk Tel. (+31-70) 340-2040, Tx. 31 651 epo nl, Fax: (+31-70) 340-3016		Authorized officer Fischer, O

INTERNATIONAL SEARCH REPORT

International Application No
PCT/US 03/38938

C.(Continuation) DOCUMENTS CONSIDERED TO BE RELEVANT		
Category *	Citation of document, with indication, where appropriate, of the relevant passages	Relevant to claim No.
X	US 6 269 266 B1 (LEYSIEFFER HANS) 31 July 2001 (2001-07-31)	1-4,6,8, 9,12,14, 17
A	column 7, line 9 -column 11, line 20; figures 1-8	5,7,10, 11,13, 15,16
A	----- US 6 016 449 A (UPTON ADRIAN R M ET AL) 18 January 2000 (2000-01-18) column 11, line 9 -column 13, line 65 column 29, line 14-56; figures 1,2,20,21 -----	1-17

INTERNATIONAL SEARCH REPORT

In International Application No

PCT/US 03/38938

Patent document cited in search report	Publication date	Patent family member(s)	Publication date
US 6358281	B1	19-03-2002	AU 770943 B2 11-03-2004
			AU 1845901 A 12-06-2001
			WO 0139830 A2 07-06-2001
			CA 2384248 A1 07-06-2001
			EP 1233812 A2 28-08-2002
			US 2002019669 A1 14-02-2002
US 6308101	B1	23-10-2001	US 6067474 A 23-05-2000
			US 6272382 B1 07-08-2001
			US 6321126 B1 20-11-2001
US 2002051550	A1	02-05-2002	DE 10041727 A1 02-05-2002
			AU 6361001 A 28-02-2002
			EP 1181953 A2 27-02-2002
US 6269266	B1	31-07-2001	DE 19837912 C1 28-10-1999
			AT 215739 T 15-04-2002
			AU 751478 B2 15-08-2002
			AU 2601899 A 09-03-2000
			CA 2270683 A1 20-02-2000
			DE 59803622 D1 08-05-2002
			EP 0982784 A1 01-03-2000
US 6016449	A	18-01-2000	CA 2251852 A1 27-04-1999
			EP 0911061 A2 28-04-1999
			US 6061593 A 09-05-2000
			US 2002099412 A1 25-07-2002
			US 6128538 A 03-10-2000
			US 6134474 A 17-10-2000
			US 6427086 B1 30-07-2002
			US 6354299 B1 12-03-2002
			US 6360122 B1 19-03-2002
			US 6597954 B1 22-07-2003
			US 2001056290 A1 27-12-2001
			US 2002002390 A1 03-01-2002
			US 2001051819 A1 13-12-2001